

Before returning this product call

1-800-4-DEWALT

**IF YOU SHOULD EXPERIENCE A PROBLEM WITH YOUR
DEWALT PURCHASE,
call 1-800-4-DEWALT**

**IN MOST CASES, A DEWALT REPRESENTATIVE CAN RESOLVE
YOUR PROBLEM OVER THE PHONE.**

**IF YOU HAVE A SUGGESTION OR COMMENT, GIVE US A CALL.
YOUR FEEDBACK IS VITAL TO THE SUCCESS OF
DEWALT'S QUALITY IMPROVEMENT PROGRAM.**

Questions? See us on the World Wide Web at www.dewalt.com

**INSTRUCTION MANUAL
GUIDE D'UTILISATION
MANUAL DE INSTRUCCIONES**

**INSTRUCTIVO DE OPERACIÓN, CENTROS DE SERVICIO Y PÓLIZA
DE GARANTÍA. ADVERTENCIA: LÉASE ESTE INSTRUCTIVO ANTES
DE USAR EL PRODUCTO.**

DEWALT®

DW744

Heavy-Duty 10" (254 mm) Job Site Table Saw

Banc de scie circulaire industrielle de chantier de 254 mm (10 po)

Sierra de banco para el lugar de trabajo de 254 mm (10 pulg.) de alta resistencia

Definitions: Safety Guidelines

The definitions below describe the level of severity for each signal word. Please read the manual and pay attention to these symbols.

⚠ DANGER: Indicates an imminently hazardous situation which, if not avoided, will result in **death or serious injury**.

⚠ WARNING: Indicates a potentially hazardous situation which, if not avoided, could result in **death or serious injury**.

⚠ CAUTION: Indicates a potentially hazardous situation which, if not avoided, may result in **minor or moderate injury**.

NOTICE: Indicates a practice **not related to personal injury** which, if not avoided, may result in **property damage**.

IF YOU HAVE ANY QUESTIONS OR COMMENTS ABOUT THIS OR ANY DEWALT TOOL, CALL US TOLL FREE AT: 1-800-4-DEWALT (1-800-433-9258).

General Safety Rules

⚠ WARNING: Read all instructions before operating product. Failure to follow all instructions listed below may result in electric shock, fire and/or serious injury.

SAVE THESE INSTRUCTIONS

⚠ WARNING: FOLLOW ALL WIRING CODES and recommended electrical connections to prevent shock or electrocution.

Grounding Instructions

If saw is of grounded construction, read the following instructions.

⚠ DANGER: SHOCK HAZARD. THIS MACHINE MUST BE GROUNDED WHILE IN USE. SERIOUS INJURY COULD RESULT.

ALL GROUNDED, CORD-CONNECTED MACHINES

In the event of a malfunction or breakdown, grounding provides a path of least resistance for electric current to reduce the risk of electric shock. This machine is equipped with an electric cord having an equipment-grounding conductor and a grounding plug. The plug must be plugged into a matching outlet that is properly installed and grounded in accordance with all local codes and ordinances. Do not modify the plug provided - if it will not fit the outlet, have the proper outlet installed by a qualified electrician. Improper connection of the equipment-grounding conductor can result in risk of electric shock. The conductor with insulation having an outer surface that is green with or without yellow stripes is the equipment-grounding conductor. If repair or replacement of the electric cord or plug is necessary, do not connect the equipment-grounding conductor to a live terminal. Check with a qualified electrician or service personnel if the grounding instructions are not completely understood, or if in doubt as to whether the machine is properly grounded. Use only three-wire extension cords that have three-prong grounding type plugs and matching three-conductor receptacles that accept the machine's plug, as shown in Figure A. Repair or replace damaged or worn cord immediately.

GROUNDED, CORD-CONNECTED MACHINES INTENDED FOR USE ON A SUPPLY CIRCUIT HAVING A NOMINAL RATING LESS THAN 150 VOLTS

If the machine is intended for use on a circuit that has an outlet that looks like the one illustrated in Fig. A, the machine will have a grounding plug that looks like the plug illustrated in Fig. A. A temporary adapter, which looks like the adapter illustrated in Fig. B, may be used to connect this plug to a matching two-conductor receptacle as shown in Fig. B if a properly grounded outlet is not available. The temporary adapter should be used only until a properly grounded outlet can be installed by a qualified electrician. The

green-colored rigid ear, lug, and the like, extending from the adapter must be connected to a permanent ground such as a properly grounded outlet box. Whenever the adapter is used, it must be held in place with a metal screw. DO NOT use a sheet metal screw.

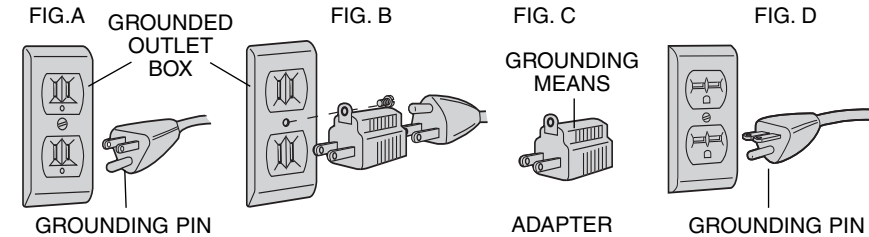

NOTE: In Canada, the use of a temporary adapter is not permitted by the Canadian Electric Code.

⚠ DANGER: IN ALL CASES, MAKE CERTAIN THAT THE RECEPTACLE IN QUESTION IS PROPERLY GROUNDED. IF YOU ARE NOT SURE, HAVE A QUALIFIED ELECTRICIAN CHECK THE RECEPTACLE.

Double Insulation

If saw is of double-insulated construction, read the following instructions.

This symbol  represents double insulated construction. Double insulated tools are constructed throughout with two separate layers of electrical insulation or one double thickness of insulation between you and the tool's electrical system. Tools built with this insulation system are not intended to be grounded. As a result, your tool is equipped with a two prong plug which permits you to use extension cords without concern for maintaining a ground connection. Repair or replace damaged or worn cord immediately.

NOTE: Double insulation does not take the place of normal safety precautions when operating this tool. The insulation system is for added protection against injury resulting from a possible electrical insulation failure within the tool.

POLARIZED PLUGS

To reduce the risk of electric shock, this equipment has a polarized plug (one blade is wider than the other). This plug will fit in a polarized outlet only one way. If the plug does not fit fully into the outlet, reverse the plug. If it still does not fit, contact a qualified electrician to install the proper outlet. Do not change the plug in any way.

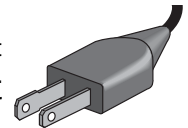

Important Safety Instructions

- **TO REDUCE THE RISK OF KICKBACK AND OTHER INJURIES,** use all components of the guarding system (blade guard assembly, riving knife and anti-kickback) for every operation for which they can be used including all through cutting.
- **REMOVE ADJUSTING KEYS AND WRENCHES.** Form habit of checking to see that keys and adjusting wrenches are removed from spindle before turning tool on. Tools, scrap pieces, and other debris can be thrown at high speed, causing injury.
- **KEEP WORK AREA CLEAN.** Cluttered areas and benches invite accidents.
- **DO NOT USE THE MACHINE IN A DANGEROUS ENVIRONMENT.** The use of power tools in damp or wet locations or in rain can cause shock or electrocution. Keep your work area well-lit to avoid tripping or placing arms, hands, and fingers in danger.
- **KEEP CHILDREN AWAY.** All visitors should be kept at a safe distance from work area. Your shop is a potentially dangerous environment.
- **MAKE WORKSHOP CHILDPROOF** with padlocks, master switches, or by removing starter keys. The unauthorized start-up of a machine by a child or visitor may result in injury.

- **DO NOT FORCE TOOL.** It will do the job better and be safer at the rate for which it was designed.
- **USE RIGHT TOOL.** Don't force tool or attachment to do a job for which it was not designed. Using the incorrect tool or attachment may result in personal injury.
- **USE PROPER EXTENSION CORD.** Make sure your extension cord is in good condition. If your product is equipped with a cord set, use only three-wire extension cords that have three-prong grounding-type plugs and three-pole receptacles that accept the tool's plug. When using an extension cord, be sure to use one heavy enough to carry the current your product will draw. An undersized cord will cause a drop in line voltage resulting in loss of power and overheating. The following table shows the correct size to use depending on cord length and nameplate ampere rating. If in doubt, use the next heavier gauge. The smaller the gauge number, the heavier the cord.

MINIMUM GAGE FOR CORD SETS

Volts	Total Length of Cord in Feet			
120V	0-25	26-50	51-100	101-150
240V	0-50	51-100	101-200	201-300
Ampere Rating	AWG			
More Than	Not more Than			
0 - 6	18	16	16	14
6 - 10	18	16	14	12
10 - 12	16	16	14	12
12 - 16	14	12	Not Recommended	

- **WEAR PROPER APPAREL.** No loose clothing, gloves, neckties, rings, bracelets, or other jewelry to get caught in moving parts. Non-slip footwear is recommended. Wear protective hair covering to contain long hair. Air vents may cover moving parts and should also be avoided.
- **ALWAYS USE SAFETY GLASSES.** Everyday eyeglasses are NOT safety glasses. Also use face or dust mask if cutting operation is dusty. All users and bystanders MUST ALWAYS wear certified safety equipment:
 - ANSI Z87.1 eye protection (CAN/CSA Z94.3),
 - ANSI S12.6 (S3.19) hearing protection,
 - NIOSH/OSHA/MSHA respiratory protection.
- **DO NOT OVERREACH.** Keep proper footing and balance at all times. Loss of balance may cause personal injury.
- **MAINTAIN TOOLS WITH CARE.** Keep blades sharp and clean for best and safest performance. Follow instructions for lubricating and changing accessories. Poorly maintained blades and machines can further damage the blade or machine and/or cause injury.
- **TURN THE MACHINE "OFF", AND DISCONNECT THE MACHINE FROM THE POWER SOURCE** before installing or removing accessories, before adjusting or changing set-ups, when making repairs or changing locations. Do not touch the plug's metal prongs when unplugging or plugging in the cord. An accidental start-up can cause injury.
- **REDUCE THE RISK OF UNINTENTIONAL STARTING.** Make sure that the switch is in the "OFF" position before plugging in the power cord. In the event of a power failure, move the switch to the "OFF" position. An accidental start-up can cause injury.
- **USE RECOMMENDED ACCESSORIES.** Use only accessories that are recommended by the manufacturer for your model. Accessories that may be suitable for one tool may be hazardous when used on another tool. Consult the instruction manual for recommended accessories. The use of improper accessories may cause risk of injury to persons.

- **NEVER STAND ON TOOL.** Serious injury could occur if the tool is tipped or if the cutting tool is unintentionally contacted.
- **CHECK FOR DAMAGED PARTS.** Before further use of the tool, a guard or other part that is damaged should be carefully checked to determine that it will operate properly and perform its intended function—check for alignment of moving parts, binding of moving parts, breakage of parts, mounting and any other conditions that may affect its operation. A guard or other part that is damaged should be properly repaired or replaced. Do not use tool if switch does not turn it on and off. Damaged parts can cause further damage to the machine and/or personal injury.
- **DIRECTION OF FEED.** Feed work into a blade or cutter against the direction of rotation of the blade or cutter only.
- **NEVER LEAVE TOOL RUNNING UNATTENDED. TURN POWER OFF.** Don't leave tool until it comes to a complete stop. Serious injury can result.
- **DO NOT OPERATE ELECTRIC TOOLS NEAR FLAMMABLE LIQUIDS OR IN GASEOUS OR EXPLOSIVE ATMOSPHERES.** Motors and switches in these tools may spark and ignite fumes.
- **STAY ALERT, WATCH WHAT YOU ARE DOING, AND USE COMMON SENSE. DO NOT USE THE MACHINE WHEN YOU ARE TIRED OR UNDER THE INFLUENCE OF DRUGS, ALCOHOL, OR MEDICATION.** A moment of inattention while operating power tools may result in serious injury.
- **DO NOT ALLOW FAMILIARITY (gained from frequent use of your saw) TO REPLACE SAFETY RULES.** Always remember that a careless fraction of a second is sufficient to inflict severe injury.

Additional Safety Rules for Table Saws

⚠WARNING: ALWAYS USE SAFETY GLASSES. Everyday eyeglasses are NOT safety glasses. Also use face or dust mask if cutting operation is dusty. All users and bystanders MUST ALWAYS wear certified safety equipment:

- ANSI Z87.1 eye protection (CAN/CSA Z94.3),
- ANSI S12.6 (S3.19) hearing protection,
- NIOSH/OSHA/MSHA respiratory protection.

⚠WARNING: Do not expose to rain or use in damp locations.

- **AVOID AWKWARD POSITIONS,** where a sudden slip could cause a hand to move into a saw blade.
- **NEVER REACH IN BACK OF, OR AROUND, THE CUTTING TOOL** with either hand to hold down the workpiece.
- **KEEP ARMS, HANDS AND FINGERS AWAY** from the blade to prevent serious injury.
- **USE A PUSH STICK THAT IS APPROPRIATE TO THE APPLICATION TO PUSH WORKPIECES THROUGH THE SAW.** A push stick is a wooden or plastic stick, usually homemade, that should be used whenever the size or shape of the workpiece would cause you to place your hands within 6" (152 mm) of the blade.
- **USE HOLD-DOWNS, JIGS, FIXTURES OR FEATHER BOARDS TO HELP GUIDE AND CONTROL THE WORKPIECE.** Accessories for use with your tool are available at extra cost from your local dealer or authorized service center. Instructions for making a push stick, a narrow rip auxiliary fence, a push block and feather boards are included in this manual.
- **DO NOT PERFORM RIPPING, CROSSCUTTING OR ANY OTHER OPERATION FREEHAND.**
- **NEVER** reach around or over saw blade.
- **STABILITY.** Make sure the table saw is firmly mounted to a secure surface before use and does not move.

- **NEVER CUT METALS, CEMENT BOARD OR MASONRY.** Certain man-made materials have special instructions for cutting on table saws. Follow the manufacturer's recommendations at all times. Damage to the saw and personal injury may result.
- **THE PROPER THROAT PLATE MUST BE LOCKED IN PLACE AT ALL TIMES** to reduce the risk of a thrown workpiece and possible injury.
- **USE THE CORRECT SAW BLADE FOR THE INTENDED OPERATION.** The blade must rotate toward the front of the saw. Always tighten the blade arbor nut securely. Before use, inspect the blade for cracks or missing teeth. Do not use a damaged or dull blade.
- **NEVER ATTEMPT TO FREE A STALLED SAW BLADE WITHOUT FIRST TURNING THE MACHINE OFF AND DISCONNECTING THE SAW FROM THE POWER SOURCE.** If a workpiece or cut-off piece becomes trapped inside the blade guard assembly, turn saw off and wait for blade to stop before lifting the blade guard assembly and removing the piece.
- **NEVER START THE MACHINE** with the workpiece against the blade to reduce the risk of a thrown workpiece and personal injury.
- **NEVER have any part of your body in line with the path of the saw blade.** Personal injury may occur.
- **NEVER PERFORM LAYOUT, ASSEMBLY OR SET-UP WORK** on the table/work area when the machine is running. A sudden slip could cause a hand to move into the blade. Severe injury can result.
- **CLEAN THE TABLE/WORK AREA BEFORE LEAVING THE MACHINE.** Lock the switch in the "OFF" position and disconnect from the power source to prevent unauthorized use.
- **DO NOT leave a long board (or other workpiece) unsupported so the spring of the board causes it to shift on the table resulting in loss of control and possible injury.** Provide proper support for the workpiece, based on its size and the type of operation to be performed. Hold the work firmly against the fence and down against the table surface.
- **IF YOUR SAW** makes an unfamiliar noise or if it vibrates excessively, cease operating immediately, turn unit off and disconnect from power source until the problem has been located and corrected. Contact a DEWALT factory service center, a DEWALT authorized service center or other qualified service personnel if the problem can not be found.
- **KEEP OUT** of the line of saw blade. Stand to the side whenever possible.
- **USE RECOMMENDED ACCESSORIES.** The use of improper accessories may cause risk of personal injury.
- **DO NOT OPERATE THIS MACHINE** until it is completely assembled and installed according to the instructions. A machine incorrectly assembled can cause serious injury.
- **OBTAIN ADVICE** from your supervisor, instructor, or another qualified person if you are not thoroughly familiar with the operation of this machine. Knowledge is safety.
- **ADDITIONAL INFORMATION** regarding the safe and proper operation of power tools (i.e., a safety video) is available from the Power Tool Institute, 1300 Sumner Avenue, Cleveland, OH 44115-2851 (www.powertoolinstitute.com). Information is also available from the National Safety Council, 1121 Spring Lake Drive, Itasca, IL 60143-3201. Please refer to the U.S. Department of Labor OSHA 1910.213 Regulations.

TERMS: THE FOLLOWING TERMS WILL BE USED THROUGHOUT THE MANUAL AND YOU SHOULD BECOME FAMILIAR WITH THEM.

- **Thru-sawing** refers to any cut that completely cuts through the workpiece.
- **Non thru-sawing** refers to any cut that does not completely cut through the workpiece.
- **Push Stick** refers to a wooden or plastic stick, usually homemade, that is used to push small workpiece through the saw and keeps the operator's hands clear of the blade.

- **Kickback** occurs when the saw blade binds in the cut and violently thrusts the workpiece back toward the operator.
- **Freehand** refers to cutting without the use of a miter gauge or rip fence or any other means of guiding or holding the workpiece other than the operator's hand. **⚠WARNING:** Never perform freehand cutting with this saw.
- **Plunge cutting** refers to blind cuts in the workpiece made by either raising the blade through the workpiece or lowering the workpiece down to the blade. **⚠WARNING:** Never perform plunge cutting with this saw.
- **Resawing** - Flipping material to make a cut the saw is not capable of making in one pass. **⚠WARNING:** Resawing **IS NOT** recommended.

SAW BLADE GUARD ASSEMBLY, ANTI-KICKBACK ASSEMBLY AND RIVING KNIFE

Your table saw is equipped with a blade guard assembly, anti-kickback assembly and riving knife that covers the blade and reduces the possibility of accidental blade contact. The riving knife is a flat plate that fits into the cut made by the saw blade and effectively fights kickback by lessening the tendency of the blade to bind in the cut. **The blade guard assembly and anti-kickback assembly can only be used when making through cuts that sever the wood. When making rabbets and other cuts that make non through cuts, the blade guard assembly and anti-kickback assembly must be removed and riving knife lowered to the non through cut position marked on the riving knife.** Two anti-kickback pawls are located on the sides of the riving knife that allow the wood to pass through the blade in the cutting direction but reduce the possibility of the material being thrown backwards toward the operator.

Use all components of the guarding system (blade guard assembly, riving knife and anti-kickback assembly) for every operation for which they can be used including all through cutting. If you elect not to use any of these components for a particular application exercise additional caution regarding control of the workpiece, the use of push sticks, the position of your hands relative to the blade, the use of safety glasses, the means to avoid kickback and all other warnings contained in this manual and on the saw itself. **Replace the guarding systems as soon as you return to thru-cutting operations.** Keep the guard assembly in working order.

MAKING A PUSH STICK (Inside Back Cover)

- In order to operate your table saw safely you must use a push stick whenever the size or shape of the workpiece would cause your hands to be within 6" (152 mm) of the saw blade or other cutter. A push stick is included with this saw.
- No special wood is needed to make additional push-sticks as long as it's sturdy and long enough. A length of 15.7" (400 mm) is recommended with a notch that fits against the edge of the workpiece to prevent slipping. It's a good idea to have several push sticks of the same length [15.7" (400 mm)] with different size notches for different workpiece thicknesses.
- See the inside back cover for a picture of a push stick. The shape can vary to suit your own needs as long as it performs its intended function of keeping your hands away from the blade.

KICKBACKS

KICKBACKS: Kickbacks can cause serious injury. A kickback occurs when a part of the workpiece binds between the saw blade and the rip fence, or other fixed object, and rises from the table and is thrown toward the operator. Kickbacks can be avoided by attention to the following conditions.

How to Avoid Them and Protect Yourself from Possible Injury

- a. Be certain that the rip fence is parallel to the saw blade.
- b. Do not rip by applying the feed force to the section of the workpiece that will become the cut-off (free) piece. Feed force when ripping should always be applied between the saw blade and the fence; use a push stick for narrow work, 6" (152 mm) wide or less.
- c. Keep saw blade guard assembly, riving knife and anti-kickback assembly in place and operating properly. If anti-kickback assembly is not operational, return your unit

to the nearest authorized DEWALT service center for repair. The riving knife must be in alignment with the saw blade and the anti-kickback assembly must stop a kickback once it has started. Check their action before ripping by pushing the wood under the anti-kickback assembly. The teeth must prevent the wood from being pulled toward the front of the saw.

- Plastic and composite (like hardboard) materials may be cut on your saw. However, since these are usually quite hard and slippery, the anti-kickback pawls may not stop a kickback. Therefore, be especially attentive to following proper set up and cutting procedures for ripping.
- Use saw blade guard assembly, anti-kickback assembly and riving knife for every operation for which it can be used, including all through-sawing.
- Push the workpiece past the saw blade prior to release.
- NEVER** rip a workpiece that is twisted or warped, or does not have a straight edge to guide along the fence.
- NEVER** saw a large workpiece that cannot be controlled.
- NEVER** use the fence as a guide or length stop when crosscutting.
- NEVER** saw a workpiece with loose knots, flaws, nails or other foreign objects.
- NEVER** rip a workpiece shorter than 10" (254 mm).
- NEVER** use a dull blade – replace or have resharpened.

WARNING: Some dust created by power sanding, sawing, grinding, drilling, and other construction activities contains chemicals known to the State of California to cause cancer, birth defects or other reproductive harm. Some examples of these chemicals are:

- lead from lead-based paints,
- crystalline silica from bricks and cement and other masonry products, and
- arsenic and chromium from chemically-treated lumber (CCA).

Your risk from these exposures varies, depending on how often you do this type of work. To reduce your exposure to these chemicals: work in a well-ventilated area, and work with approved safety equipment, such as those dust masks that are specially designed to filter out microscopic particles.

- Avoid prolonged contact with dust from power sanding, sawing, grinding, drilling and other construction activities. Wear protective clothing and wash exposed areas with soap and water.** Allowing dust to get into your mouth, eyes or lay on the skin may promote absorption of harmful chemicals.

WARNING: Use of this tool can generate and/or disburse dust, which may cause serious and permanent respiratory or other injury. Always use NIOSH/OSHA approved respiratory protection appropriate for the dust exposure. Direct particles away from face and body. Always operate tool in well-ventilated area and provide for proper dust removal. Use dust collection system wherever possible.

SAVE THESE INSTRUCTIONS FOR FUTURE USE

Specifications

Amperes	15 A
Table Size	19-1/4" (489 mm) x 26-1/2" (673 mm)
Miter Angle	30° L&R
Bevel Angle	0° to 45°L
Blade Size	10" (254 mm)
Max. Cut Depth	0° Bevel 3-1/8" (79 mm)
Max. Cut Depth	45° Bevel 2-1/4" (57 mm)
RPM, no load	3650

Unpacking

WARNING: To reduce the risk of injury, **DO NOT** connect the machine to the power source until the table saw is completely assembled and you read the entire instruction manual.

Open the box and slide the saw out, as shown in Figure 1.

Carefully unpack the table saw and all loose items from the carton. Examine all parts to make sure that parts have not been damaged during shipping. If any parts are missing or damaged, contact your dealer to replace them before attempting to assemble the tool.

Figure 2 shows all the loose items and hardware packed with the saw.

- Rip fence
- Blade (attached to saw base)
- Arbor wrench and spindle wrench (attached to saw base)
- Blade guard assembly
- Throat plate
- Miter gauge
- Push stick (attached to the rip fence)

WARNING: To reduce the risk of serious personal injury, have push stick ready to use before starting cut.

FIG. 2

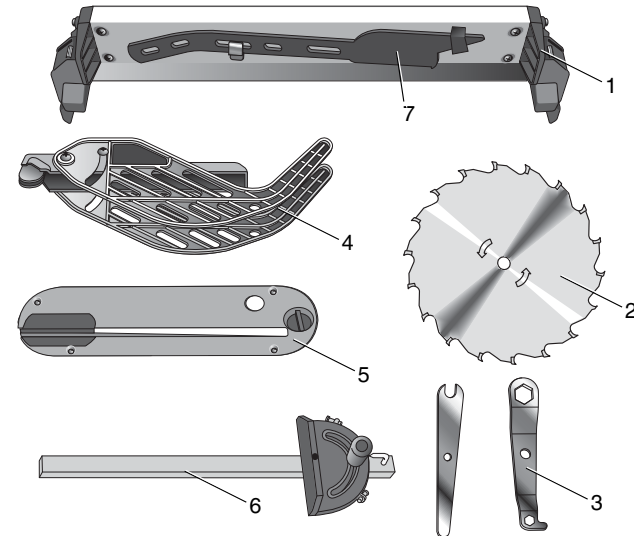
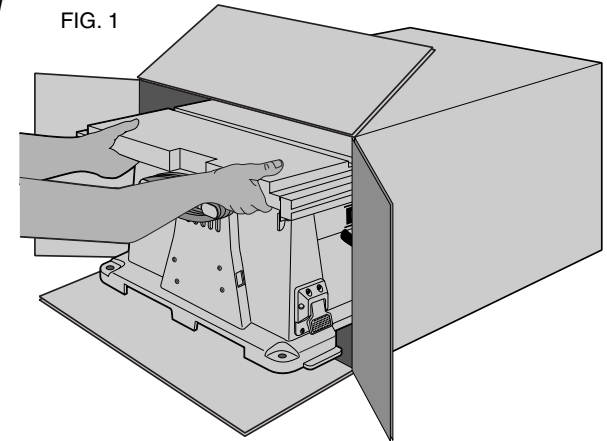

FIG. 1



FEATURES (Fig. 3, 4)

Examine Figures 3 and 4 to become familiar with the saw and its various parts. The following sections on assembly and adjustments will refer to these terms and you must know what and where the parts are.

FIG. 3

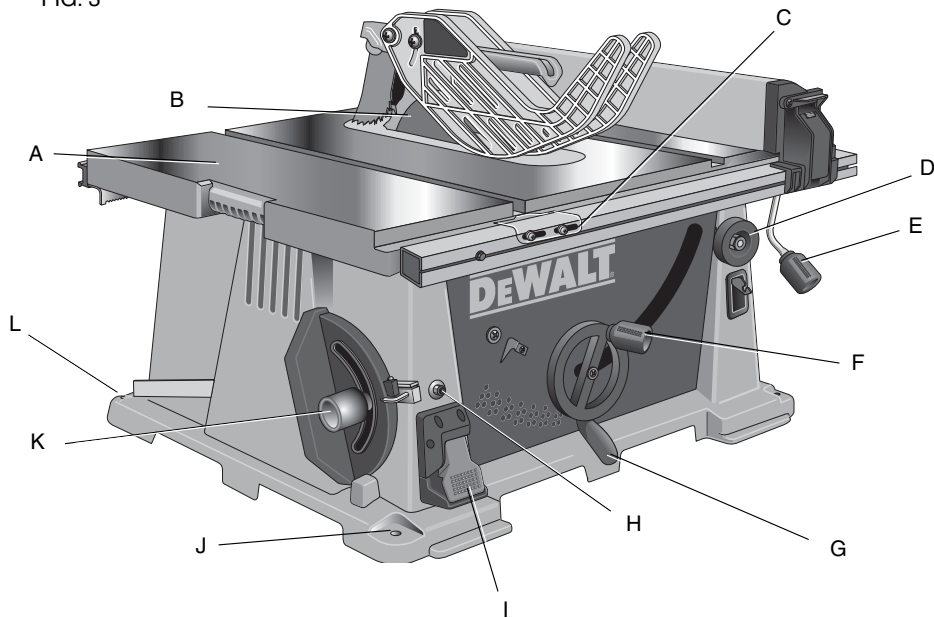

FIG. 4

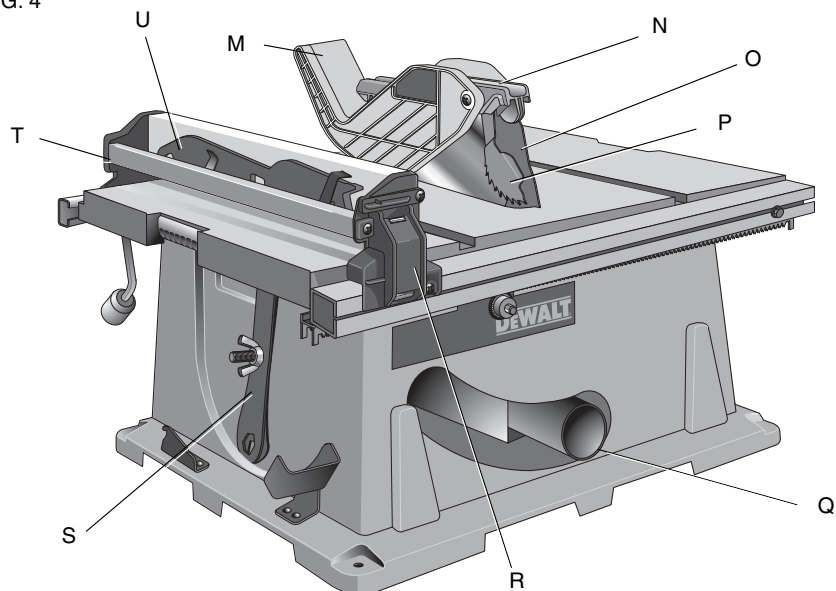

FIGURE 3

- A. Table
- B. Blade
- C. Rip scale indicator
- D. Fine adjust knob
- E. Rail lock lever
- F. Blade height adjustment wheel

- G. Bevel lock lever
- H. Circuit breaker button
- I. ON/OFF switch
- J. Mounting holes
- K. Miter gauge
- L. Screw down holes

FIGURE 4

- M. Blade guard assembly
- N. Blade guard lock lever
- O. Riving knife
- P. Anti-kickback assembly
- Q. Dust collection port
- R. Rip fence rear latch
- S. Arbor wrench, spindle wrench
- T. Work Support Extension (retracted)
- U. Push stick

ASSEMBLY

⚠WARNING: Shock Hazard. To reduce the risk of serious personal injury, turn unit off and disconnect machine from power source before attempting to move it, change accessories or make any adjustments. An accidental start-up can cause injury.

YOUR SAW SHOULD BE ASSEMBLED IN THE FOLLOWING ORDER:

1. Blade
2. Throat plate
3. Rip fence (**NOTE:** Adjust rip scale before proceeding. See **Adjusting Rip Scale.**)
4. Anti-kickback assembly
5. Blade guard assembly

Tools needed for assembly include the wrenches included with your saw.

ATTACHING/REPLACING THE BLADE

1. Raise the saw blade arbor to its maximum height by turning the blade height adjustment wheel clockwise.
2. Remove the arbor nut (W) and flange from the saw arbor by turning counterclockwise.

FIG. 5A

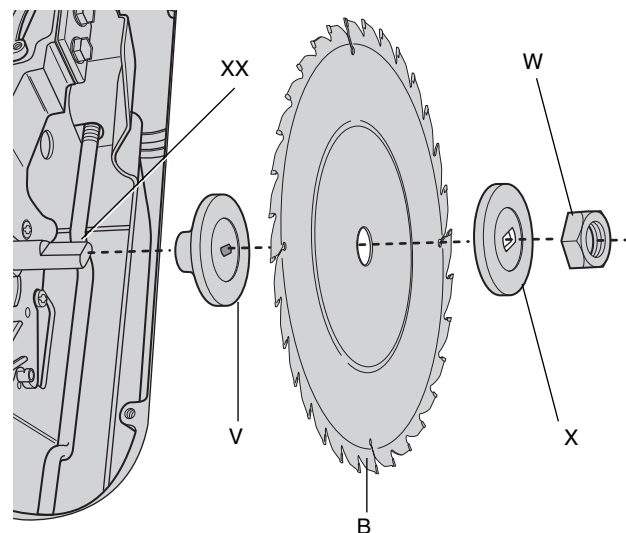

- Place the saw blade on to the spindle (XX) making sure the teeth of the blade (B) point down at the front of the table. Assemble the washers and arbor nut to the spindle and tighten arbor nut (W) as far as possible by hand, making sure that the saw blade is against the inner washer (V) and the large washer (X) diameters are against the blade. Ensure the side of outer washer marked "Blade Side" is against the blade (see Figure 5A). Ensure the spindle and washers are free from dust and debris.

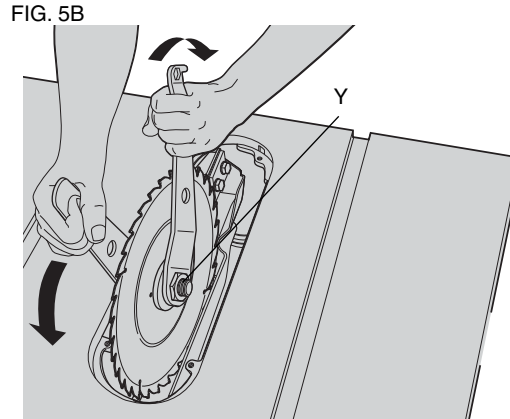

- To keep the spindle from rotating when tightening the arbor nut, use the open-ended spindle wrench to secure the spindle (Fig. 5B).
- Using the arbor wrench, tighten the arbor nut by turning it clockwise (Fig. 5B).
- NOTE:** Different types of blades make different kerfs (width of cuts). Therefore, it is necessary to check adjustment of rip scale when changing blades. Replacement blade **MUST** not exceed the thickness stated on the riving knife. The riving knife provided with the saw is 2.2 mm thick.

POSITIONING THE RIVING KNIFE (FIG. 6)

- Raise the saw blade arbor to its maximum height.
- Loosen the riving knife lock knob (YY) (minimum of three turns).
- To disengage riving knife lock pin, push lock knob toward the riving knife as indicated by the yellow arrows on the knob.

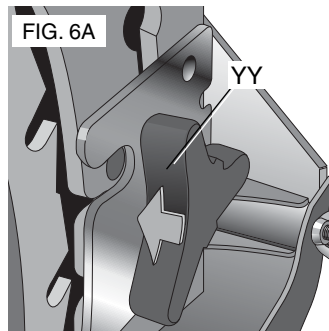

FIG. 6A

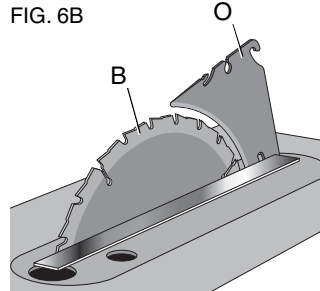

FIG. 6B

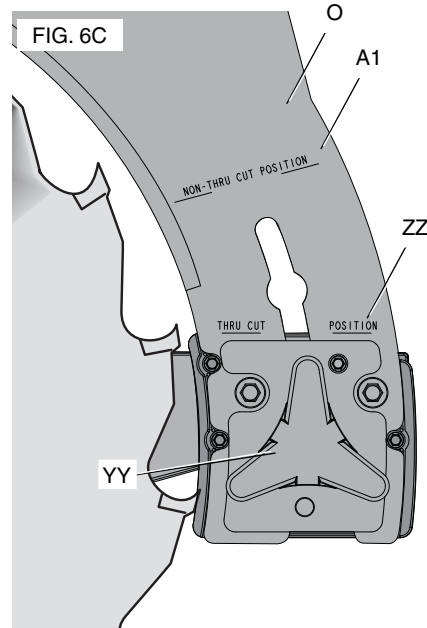

FIG. 6C

- Lift and slide the riving knife to the approximate position indicated by the markings (non-thru and thru-position) on the riving knife and the lock pin will snap into place.

- Tighten the riving knife lock knob.

⚠WARNING: Before connecting the table saw to the power source or operating the saw, always inspect the blade guard assembly and riving knife for proper alignment and clearance with saw blade. Check alignment after each change of bevel angle.

NOTE: DO NOT operate saw if riving knife is not locked in the thru-cut (ZZ) or non thru-cut position (A1) hole.

When properly aligned, the riving knife will be in line with the blade at both table top level, and at the top of the blade. Using a straight edge, ensure that the blade (B) is aligned with the riving knife (O) as shown in Figure 6B. With power disconnected, operate the blade tilt and height adjustments through the extremes of travel and insure the blade guard assembly clears the blade in all operations and that the anti-kickback assembly is functioning.

TO ASSEMBLE THE THROAT PLATE (FIG. 7)

- Align the throat plate as shown in Figure 7, and insert the tabs on the back of the throat plate into the holes on the back of the table opening.
- Rotate cam counterclockwise until the front of throat plate drops into place. Secure by rotating cam lock knob (EE) clockwise 1/4 turn (when cam lock is under the table holding the throat plate in place).
- The throat plate includes four adjustment screws which raise or lower the throat plate. When properly adjusted, the front of the throat plate should be flush or slightly below the surface of the table top and secured in place. The rear of the throat plate should be flush or slightly above the table top.

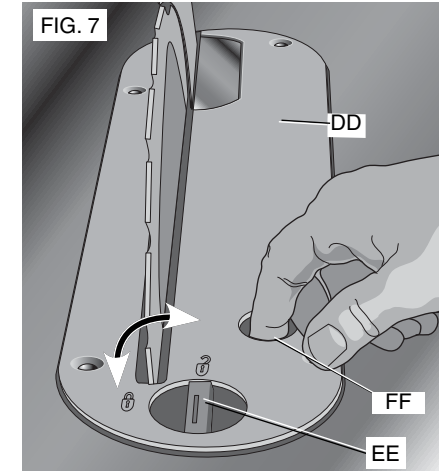

FIG. 7

TO REMOVE THE THROAT PLATE (FIG. 7)

- Remove the throat plate (DD) by turning the cam lock knob (EE) 1/4 turn counterclockwise
- Using finger hole (FF) on the plate, pull throat plate up and forward to expose the inside of the saw.

⚠WARNING: To reduce the risk of serious personal injury, the throat plate must be locked in place at all times.

ASSEMBLING THE RIP FENCE (FIG. 8, 9)

The rip fence can be installed on the left or right side of your table saw.

- Align the locator screw (GG) on the fence rail with the fence head slot and align the latch (R) with the opening (HH).
- Secure the rip fence by snapping the latches onto the rails as shown in Figure 9. Be sure to snap both front and rear latches in place.

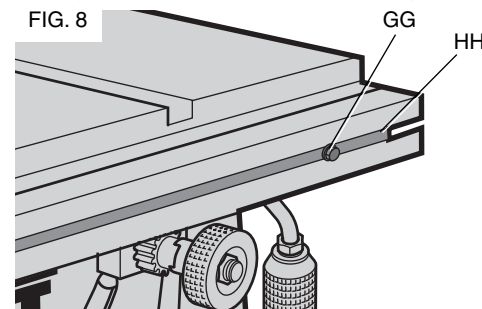

FIG. 8

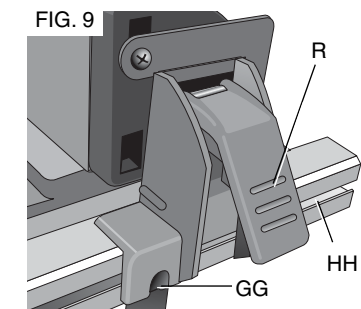
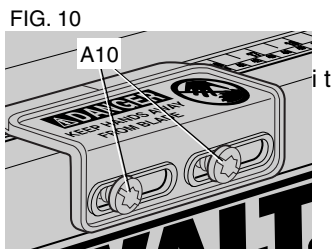

FIG. 9

ADJUSTING THE RIP SCALE (FIG. 1, 10)

1. Unlock the rail lock lever (E).
2. Set the blade at 0° bevel and move the fence in until touches the blade.
3. Lock the rail lock lever.
4. Loosen the rip scale indicator screws (A10) and set the rip scale indicator to read zero (0). Retighten the rip scale indicator screws. The rip scale reads correctly only when the fence is mounted on the right side of the blade.



ANTI-KICKBACK ASSEMBLY (FIG. 11, 12)

⚠WARNING: To reduce the risk of serious personal injury, the anti-kickback assembly must be in place for all possible cuts.

1. Remove the anti-kickback assembly (P) from the storage position. See **Storage** (page 14).
2. Locate the anti-kickback mounting hole and slot (Z) at the top of the riving knife (O).
3. Slide the anti-kickback housing along the top of the riving knife until the stem (AA) locates the slot above the mounting hole. Depress the stem (AA) on the anti-kickback assembly to allow the assembly to drop into the hole (Z). Push down on the anti-kickback assembly until it snaps into place and locks the assembly. **NOTE:** Pull up on the anti-kickback assembly to ensure it has locked into place.

FIG. 11

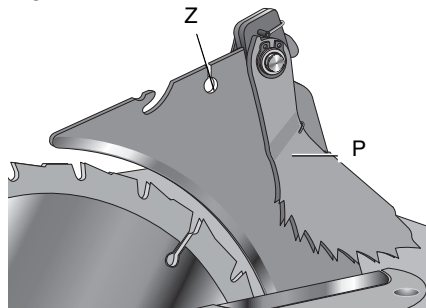
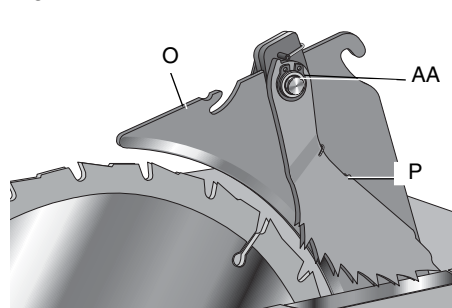

FIG. 12



Blade guard assembly (Fig. 13, 14, 15)

TO ATTACH BLADE GUARD ASSEMBLY

⚠WARNING: To reduce the risk of serious personal injury, the blade guard assembly must be in place for all possible cuts.

1. While holding the blade guard assembly (M) in a vertical position slide the locating pin (BB) into the riving knife slot (CC) centering the riving knife within the v-shaped notch in the top guard. See Figure 13.
2. Rotate the blade guard assembly towards the front of the saw while keeping the pin (BB) at the top of the riving knife slot. Rotate until the blade guard assembly is parallel to the table. See Figure 14.
3. Press the blade guard lock lever (N) down until it snaps into the locked position. Check to make sure the guard is locked onto the riving knife. If the guard is not locked the blade guard lock lever will flip up to the unlocked position. See Figure 15.

FIG. 13

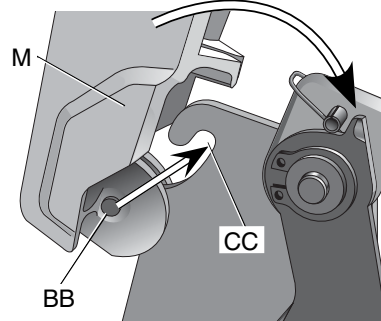

FIG. 14

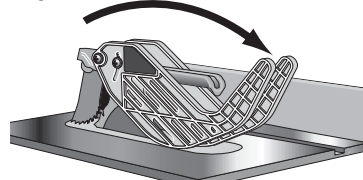

FIG. 15A

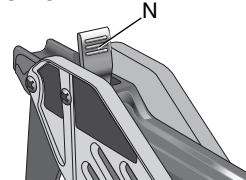
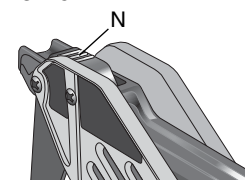

FIG. 15B



TO REMOVE THE BLADE GUARD ASSEMBLY

1. Lift the blade guard assembly lock lever (N) to the unlocked position.
2. Rotate the guard back and slide pin from riving knife slot.

Bench Mounting (Fig. 3)

⚠WARNING: To reduce the risk of serious personal injury, turn unit off and disconnect machine from power source before attempting to move it, change accessories or make any adjustments. An accidental start-up can cause injury.

⚠CAUTION: To reduce the risk of personal injury, make sure table saw is firmly mounted before use.

⚠CAUTION: Ensure that the surface is stable enough that large pieces of material will not cause it to tip over during use.

The table saw must be mounted firmly. **The mounting surface must have a 15" by 20" (38 x 51 cm) opening to allow dust to escape.**

Four holes (J) are provided in the tool's feet for mounting. We strongly recommend that these holes be used to anchor the table saw to your workbench or other stationary rigid frame. Alternately, to enhance the saw's portability, it can be mounted to a piece of wood that can be "C" clamped to your work surface and stand. The DEWALT DW7440 Table Saw Stand and the DW7440RS Rolling Stand are designed for use with the DW744. They are available from your local DEWALT dealer or service center.

1. Center the saw on a square piece of 1/2" (12.7 mm) plywood. The plywood must have a 15" x 20" (38 x 51cm) opening to allow dust to escape.
2. Mark the positions of the four mounting holes in the base of the saw with a pencil.
3. Remove the saw and drill 1/4" (6.4 mm) holes in the places you have just marked.
4. Position the saw over the four holes you drilled in the plywood and insert four 1/4" (6.4 mm) machine screws FROM THE BOTTOM. Install washers and 1/4" (6.4 mm) nuts on the top. Tighten securely.
5. In order to prevent the screw heads from marring the surface to which you clamp the saw, attach two strips of scrap wood to the bottom of the plywood base. These strips can be attached with wood screws installed from the top side as long as they don't protrude through the bottom of the strip.
6. "C" clamp the plywood base to your workbench whenever you want to use the saw.

Connecting Saw to Power Source

⚠WARNING: To reduce the risk of injury, before connecting saw to power source, make sure the switch is in the OFF position.

Be sure your power supply agrees with the nameplate marking. AC ONLY means that your saw will operate on alternating current only. A voltage decrease of 10 percent or more will cause a loss of power and overheating. All DEWALT tools are factory tested. If this tool does not operate, check the power supply.

Rip Fence Operation

RAIL LOCK LEVER (FIG. 16)

The rail lock lever (E) locks the fence in place preventing movement during cutting. **To lock the rail lever**, push it down and toward the rear of the saw. **To unlock**, pull it up and toward the front of the saw.

NOTE: When ripping, always lock the rail lock lever.

WORK SUPPORT EXTENSION

Your table saw is equipped with a work support extension to support work that extends beyond the saw table. To use the work support extension, rotate it as shown in Figure 17. When not in use, the work support extension retracts, as shown in Figure 18.

NOTE: Retract the work support extension whenever working over the table.

FIG. 17

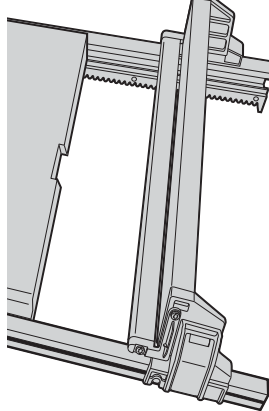
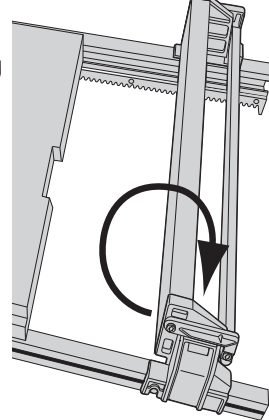

FIG. 18



FINE ADJUSTMENT KNOB (FIG. 19)

The fine adjustment knob (D) allows smaller adjustments when setting the fence. Before adjusting, be sure the rail lock lever is in its up or unlocked, position.

RIP SCALE POINTER

The rip scale pointer will need to be adjusted for proper performance of the rip fence if the user switches between thick and thin kerf blades. See **Adjusting the Rip Scale** under *Assembly*.

FIG. 16

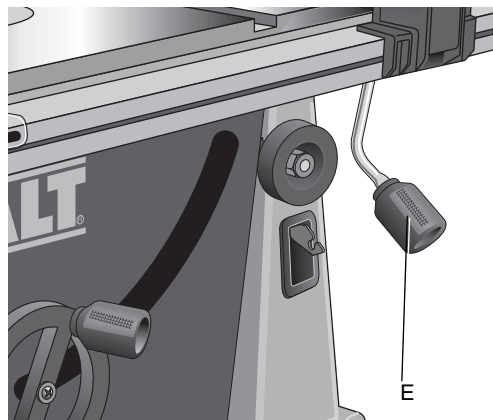
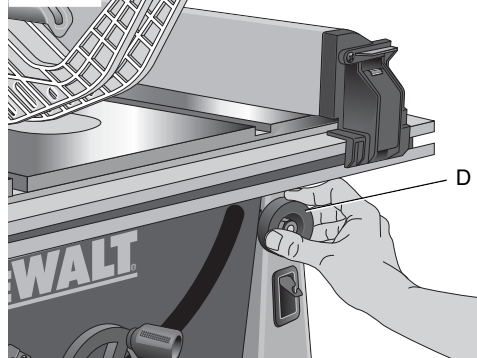

FIG. 19



On-Off Switch

⚠WARNING: To reduce the risk of injury, be sure switch is in the OFF position before plugging machine in.

Lift the switch paddle (I) up to turn your saw ON and push it down to turn your saw OFF.

A hole (JJ) is provided in the switch for insertion of a padlock to lock the saw off (Fig. 20).

Adjustments

⚠WARNING: To reduce the risk of injury, turn unit off and disconnect machine from power source before installing and removing accessories, before adjusting or changing set-ups or when making repairs. An accidental start-up can cause injury.

NOTE: Your saw is fully and accurately adjusted at the factory at the time of manufacture. If readjustment due to shipping and handling or any other reason is required, follow the steps below to adjust your saw.

Once made, these adjustments should remain accurate. Take a little time now to follow these directions carefully to maintain the accuracy of which your saw is capable.

RAIL LOCK ADJUSTMENT (FIG. 3, 21)

1. Lock the rail lock lever (E) by pushing down.
2. On the underside of your saw, tighten the nut (KK) shown in Figure 21. Adjust this nut until the gap between the bevelled washers (LL) closes.
3. Once the springs are almost touching, tighten the nut 1/2 turn.

FIG. 21

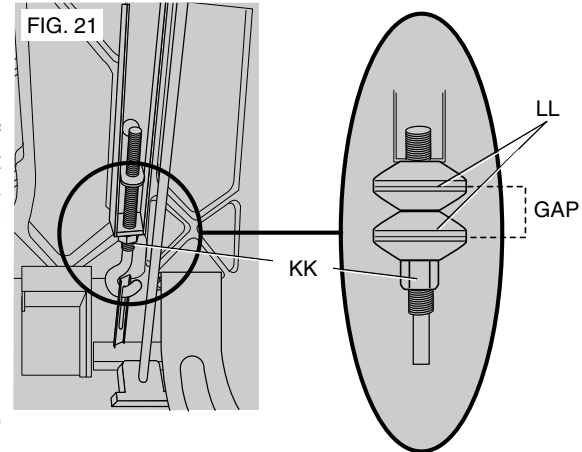

RIP SCALE ADJUSTMENT

See **Adjusting the Rip Scale** under *Assembly*.

BLADE ALIGNMENT ADJUSTMENT (FIG. 22)

(Blade Parallel to Miter Slot)

⚠WARNING: Cut Hazard. Check the blade at 0° and 45° to make sure blade does not hit the throat plate, causing personal injury.

If the blade appears to be out of alignment with the miter slot on the table top, it will require calibration for alignment. To realign the blade and miter slot, use the following procedure:

⚠WARNING: To reduce the risk of injury, turn unit off and disconnect machine from power source before installing and removing accessories, before adjusting or changing set-ups or when making repairs. An accidental start-up can cause injury.

1. Place the unit in an upright position. Using a 10 mm socket, loosen rear pivot bracket (MM) fasteners (NN) just enough to allow the bracket to move side-to-side.
2. Adjust the bracket until the blade is parallel to the miter gauge slot.
3. Tighten the rear pivot bracket fasteners to 6-8 ft.lbs. (8.1 to 10.8 Nm).

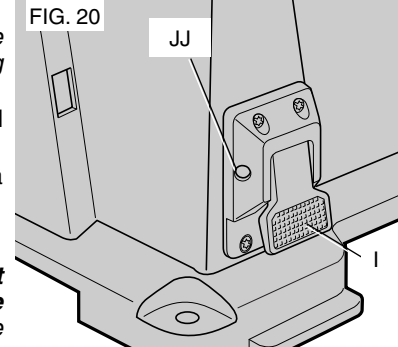
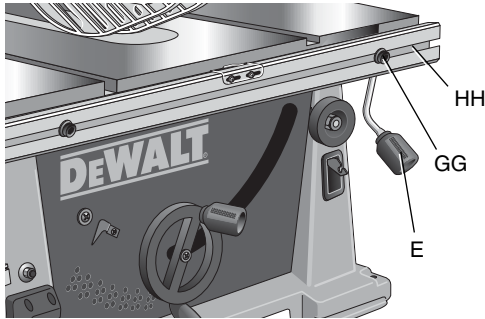

FIG. 22



BEVEL STOP AND POINTER ADJUSTMENT (FIG. 3, 23, 24)

1. Raise the blade fully by rotating the blade height adjustment wheel clockwise until it stops.
2. Unlock the bevel lock lever (G) by pushing it up and to the right. Loosen the bevel stop screw (RR, Fig. 23).
3. Place a square flat against the table top and against the blade between teeth, as shown in Figure 24. Ensure the bevel lock lever is in its unlocked, or up, position.
4. Using the bevel lock lever, adjust the bevel angle until it is flat against the square.
5. Tighten the bevel lock lever by pushing it down.
6. Turn the bevel stop cam (PP) until it firmly contacts the bearing block. Tighten the bevel stop screw (RR).
7. Check the bevel angle scale. If the pointer does not read 0°, loosen pointer screw (QQ) and move the pointer so it reads correctly. Retighten the pointer screw.
8. Repeat at 45°, but do not adjust pointer.

FIG. 23

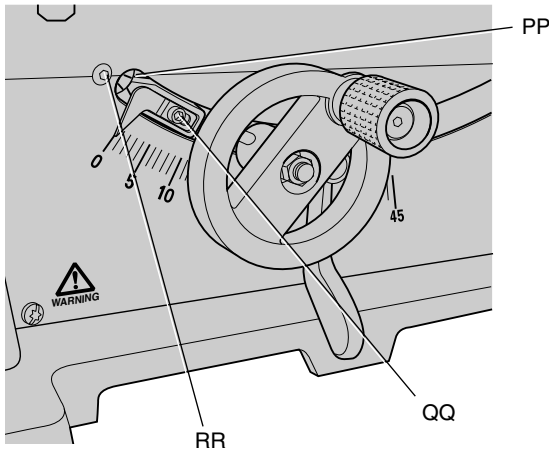

MITER GAUGE ADJUSTMENT (FIG. 25)

Your miter gauge features adjustable stops at 90° and 45° left and right. To adjust these stops, loosen the lock nuts (TT) and tighten or loosen the three adjusting screws (UU) against the stop plate (SS).

FENCE ALIGNMENT ADJUSTMENT (FIG. 22) (Blade Parallel to Fence)

If you experience fence alignment problems and want to correct an out of parallel between the fence and the blade, be sure to check the alignment of the blade to the miter slot first. After confirming that those elements are aligned, proceed with alignment of the blade to the fence using the following procedure:

1. Unlock the rail lock lever (E) and locate the two fence locator screws (GG) that support the fence on the front and rear rails.
2. Loosen the rear locator screw and adjust the position of the fence in the groove on the fence until it sets the fence face parallel to the blade. Make sure you measure from the fence face to the front and back of the blade to ensure alignment.
3. Tighten the locator screw and repeat on the left side of the blade.
4. Check rip scale pointer adjustment.

ALIGNING RIVING KNIFE TO BLADE (FIG. 26)

1. Remove the throat plate. See **To Remove Throat Plate** under *Assembly*.
2. Raise the blade to full depth of cut and 0° bevel angle.
3. If needed, raise the riving knife (O) to the thru - cut (ZZ) or highest position. See **Positioning Riving Knife** under *Assembly*.
4. Locate the four small set screws (A2) adjacent to the riving knife lock knob (YY). These screws will be used to adjust the riving knife position.

FIG. 25

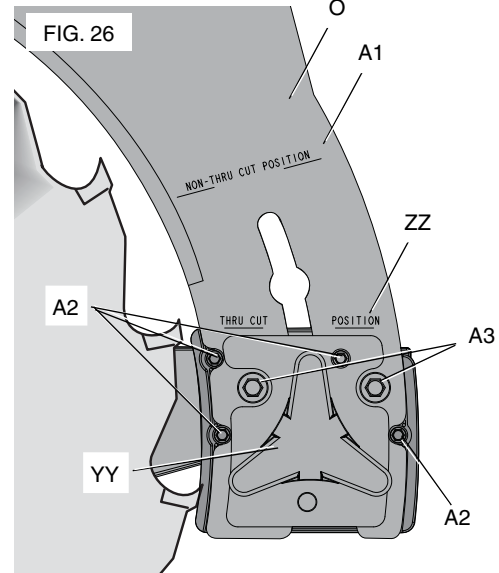
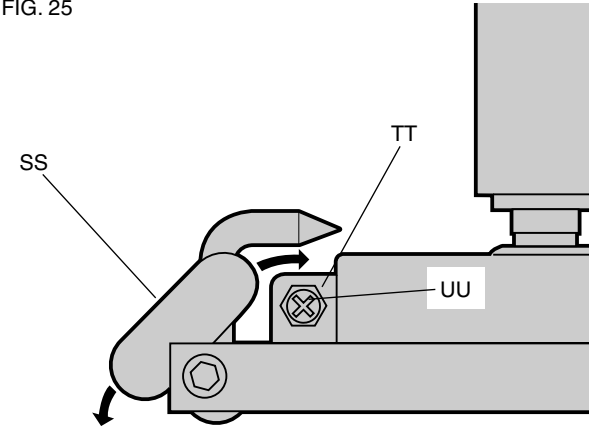

5. Lay a straight edge on the table against two blade tips. The riving knife should not touch the straight edge. If needed, loosen the two larger lock screws (A3).
6. Adjust the small set screws (A2) to move the riving knife according to the position noted in step 5. Lay the straight edge on the opposite side of the blade and repeat adjustments as needed.
7. Lightly tighten the two larger lock screws (A3).
8. Place a square flat against the riving knife to verify riving knife is vertical and in-line with the blade.
9. If needed, use the set screws to bring the riving knife vertical with the square.
10. Repeat steps 5 and 6 to verify position of riving knife.
11. Fully tighten the two larger lock screws (A3).

FIG. 24

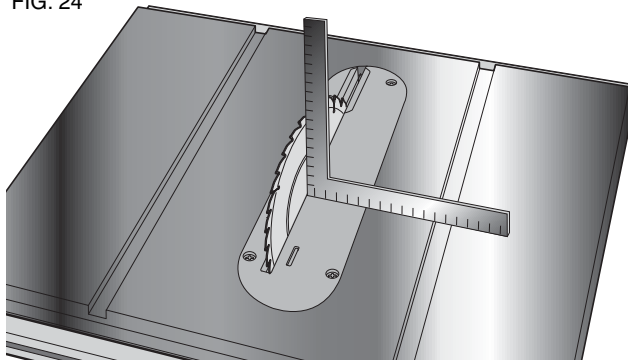

Saw Blades

⚠WARNING: Riving knives must be matched to saw blade dimensions in order to function effectively. See **Riving Knife Selection**.

THIS SAW IS INTENDED FOR USE ONLY WITH SAW BLADES 10" (254 mm) IN DIAMETER. See Fig. 27.

FIG. 27

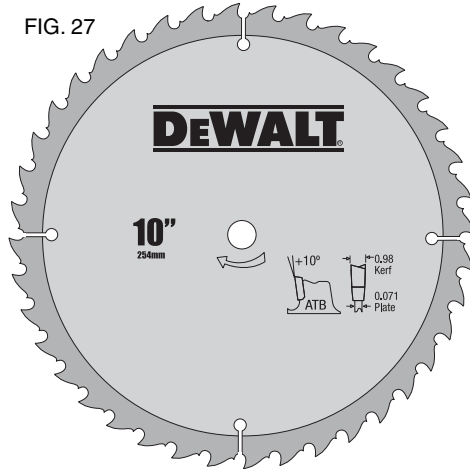

1. The saw blade furnished with your new saw is a 10" (254 mm) combination blade, used for cross cutting (across the grain) and ripping (with the grain) through the material. The center hole to fit on the arbor is 5/8" (16 mm) diameter. This blade will produce a good quality cut for most applications.
2. There are many types of blades available to do specific and special jobs such as cross cut only, rip only, hollow ground, thin plywood, paneling, etc.
3. Use only saw blades designed for maximum safe operating speeds of 5,000 RPM or greater.
4. Saw blades should always be kept sharp. It is recommended that you locate a reputable sharpening service to sharpen your blades when needed.
5. Never stack blades on top of one another to store. Place material such as cardboard between them to keep the blades from coming in contact with one another.

⚠CAUTION: Abrasive wheels or blades (including diamond) should not be used on this saw.

Riving Knife Selection

⚠WARNING: To minimize the risk of kickback and to insure proper cutting, the riving knife must be the proper thickness for the blade used.

The riving knife supplied with this table saw is the correct size for the blade supplied with the saw.

If a different blade is used, check the blade body, or plate, thickness and the blade kerf, or cutting, width marked on the blade or on the blade packaging. The riving knife thickness must be greater than the body thickness and less than the kerf width as shown in Fig. 28. If it is not, the riving knife **MUST** be replaced with one that has the correct thickness.

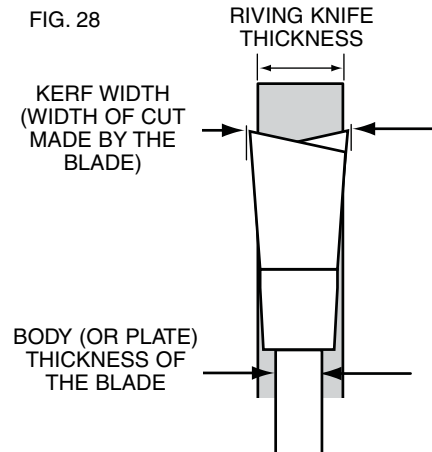

The riving knife provided with this saw is marked as follows (Fig. 29):

0.087" (2.2 mm) THICK RIVING KNIFE. ONLY USE FOR 10" (254 mm) Ø BLADE WITH 0.094" (2.4 mm) MIN. KERF WIDTH AND 0.067" (1.75 mm) MAX. BODY THICKNESS.

The Riving knife available as an accessories marketed by DEWALT is marked as follows:

0.110" (2.8 mm) THICK RIVING KNIFE. ONLY USE FOR 10" (254 mm) Ø BLADE WITH 0.118" (3.0 mm) MIN. KERF WIDTH AND 0.098" (2.5 mm) MAX. BODY THICKNESS

FIG. 29

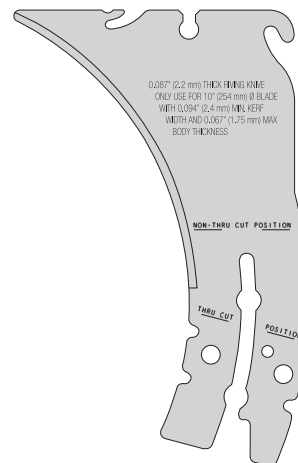

All DEWALT blade body thickness and kerf widths are provided at www.dewalt.com.

If a different blade is used and the body thickness and kerf width dimensions are not provided, use the following procedure to determine the correct riving knife thickness:

1. Measure the body thickness of the blade.
2. Make a shallow cut in scrap material and measure the kerf width.
3. Select the riving knife as shown in Fig. 28.
4. Slide the riving knife through the shallow cut made in step 2 to confirm the correct riving knife has been selected. The riving knife should not bind or drag through the cut. (Fig. 30)

FIG. 30

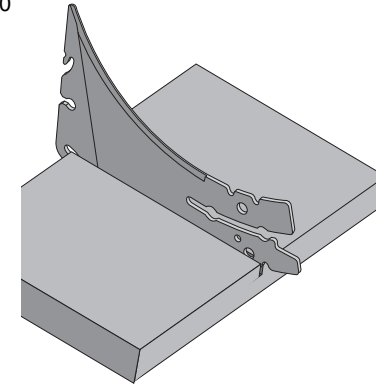

IMPORTANT: If any dragging or binding of the material is encountered as it reaches the riving knife, turn unit off and disconnect machine from power source. Repeat steps 1–4 to make the proper riving knife selection before attempting another cut.

Kickback

Kickback is a dangerous condition! It is caused by the workpiece binding against the blade. The result is that the workpiece can move rapidly in a direction opposite to the feed direction. During kickback, the workpiece could be thrown back at the operator. It can also drag the operator's hand back into the blade if the operator's hand is at the rear of the blade. If kickback occurs, turn the saw OFF and verify the proper functioning of the riving knife, anti-kickback assembly and blade guard assembly before resuming work.

⚠WARNING: See **Additional Safety Rules for Table Saws** and follow all warnings provided regarding KICKBACK.

OPERATION

⚠WARNING: Before using the saw, verify the following each and every time:

- **ALWAYS** wear proper eye, hearing and respiratory equipment.

- Blade is tight.
- Bevel angle and height lock knobs are tight.
- If ripping, ensure fence lock lever is tight and fence is parallel to the blade.
- If crosscutting, miter gauge knob is tight.
- The blade guard assembly is properly attached and the anti-kickback assembly is functioning.
- **ALWAYS** inspect the blade guard assembly and riving knife for proper alignment, operation and clearance with saw blade.
- **ALWAYS** make sure both guards are in the down position in contact with the table before operating.

Failure to adhere to these common safety rules can greatly increase the likelihood of injury.

▲WARNING: To reduce the risk of injury, turn unit off and disconnect machine from power source before installing and removing accessories, before adjusting or changing set-ups or when making repairs. An accidental start-up can cause injury.

▲WARNING: Before connecting the table saw to the power source or operating the saw, always inspect the blade guard assembly and riving knife for proper operation alignment and clearance with saw blade. Personal injury may result.

▲WARNING: Ripping or crosscutting may cause saw to tip over while operating. Make sure saw is securely mounted to a stable surface.

▲WARNING: Never use the fence and miter gauge together. This may cause a kickback condition and injure the operator.

▲CAUTION: If your saw makes an unfamiliar noise or if it vibrates excessively, cease operating immediately, turn unit off and disconnect from power source until the problem has been located and corrected. Contact a DEWALT factory service center, a DEWALT authorized service center or other qualified service personnel if the problem can not be found.

▲CAUTION: The proper throat plate must be in place at all times to reduce the risk of a thrown workpiece and possible injury.

There are two basic types of cutting with table saws: ripping and crosscutting. Cutting with the grain is ripping and cutting against the grain is crosscutting. With man made materials, the distinction is made such that ripping is cutting to a different width and crosscutting describes cutting material across the shorter dimension.

▲WARNING: When ripping, always use the fence to provide a guide for the material and blade guard assembly against a kickback situation.

▲WARNING: Never perform any cutting operation free hand. Never perform plunge cutting.

▲CAUTION: When crosscutting, always use the miter gauge.

Guard Operating Feature (Fig. 31)

▲WARNING: To reduce the risk of injury, turn unit off and disconnect machine from power source before installing and removing accessories, before adjusting or changing set-ups or when making repairs. An accidental start-up can cause injury.

1. The guard(s) will lock in place when in the raised position.
2. This feature increases visibility when measuring the blade to fence distance.
3. Push down on guard(s) and they will release to the operating position.

ALWAYS make sure both guards are in the down position in contact with the table before operating.

FIG. 31

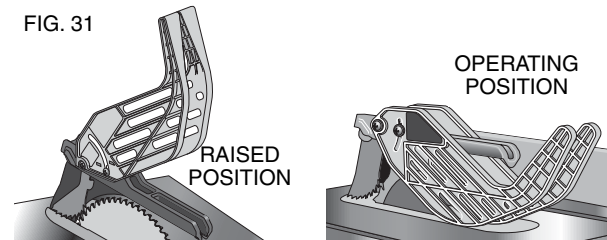

Ripping

▲WARNING: Never touch the “free end” of the workpiece or a “free piece” that is cut off, while the power is ON and/or the saw blade is rotating. Piece may contact the blade resulting in a thrown workpiece and possible injury.

▲WARNING: A rip fence should **ALWAYS** be used for ripping operations to prevent loss of control and personal injury. **NEVER** perform a ripping operation freehand. **ALWAYS** lock the fence to the rail.

▲WARNING: When bevel ripping and whenever possible, place the fence on the side of the blade so that the blade is tilted away from the fence and hands.

▲WARNING: Keep hands clear of the blade

▲WARNING: Use a push stick to feed the workpiece if there is 2–6" (51–152 mm) between the fence and the blade. Use a narrow rip auxiliary fence and push block to feed the workpiece if there is 2" (51 mm) or narrower between the fence and the blade.

1. Lock the rip fence by pressing the rail lock lever down. Remove the miter gauge.
2. Raise the blade so it is about 1/8" (3.2 mm) higher than the top of the workpiece.
3. Hold the workpiece flat on the table and against the fence. Keep the workpiece about 1" (25.4 mm) away from the blade.

FIG. 32

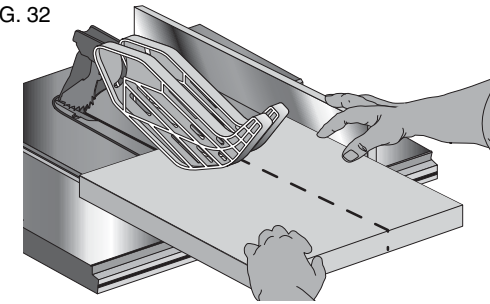

▲CAUTION: The workpiece must have a straight edge against the fence and must not be warped, twisted or bowed. Keep both hands away from the blade and away from the path of the blade. See proper hand position in Figure 32.

4. Turn the saw on and allow the blade to come up to speed. Both hands can be used in starting the cut. When there is approximately 12" (305 mm) left to be ripped, use only one hand, with your thumb pushing the material, your index and second finger holding the material down and your other fingers hooked over the fence. Always keep your thumb along side your first two fingers and near the fence.
5. Keeping the workpiece against the table and fence, slowly feed the workpiece rearward all the way through the saw blade. Continue pushing the workpiece until it is clear of the blade guard assembly and it falls off the rear of the table. Do not overload the motor.
6. Never try to pull the workpiece back with the blade turning. Turn the switch off, allow the blade to stop, raise the anti-kickback teeth on each side of the riving knife if necessary and slide the workpiece out.
7. When sawing a long piece of material or a panel, always use a work support. A sawhorse, rollers, or out feed assembly provides adequate support for this purpose. The work support must be at the same height as the saw table.

▲CAUTION: Never push or hold onto the “free” or “cut off” side of the workpiece.

Ripping Small Pieces

It is unsafe to rip small pieces. It is not safe to put your hands close to the blade. Instead, rip a larger piece to obtain the desired piece. When a small width is to be ripped and the hand cannot be safely put between the blade and the rip fence, use one or more push sticks. A pattern is included at the end of this manual to make push sticks. A push stick (U) is included with this saw, attached to the rip fence. Use the push stick(s) to hold the workpiece against the table and fence, and push the workpiece fully past the blade. See Figure 33.

FIG. 33

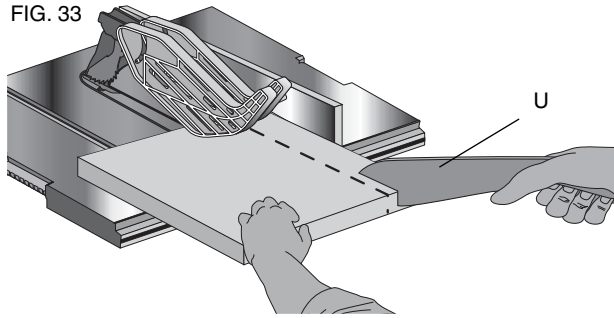

Narrow Rip Auxiliary Fence (Fig. 34, 36)

The narrow rip auxiliary fence should be used for a rip measuring 2" (50.8 mm) or narrower. This fence will allow the guard to remain on the saw when completing narrow ripping. This fence will provide ample space for proper use of a push block (A12, see **Push Block**).

1. Follow the diagram in Fig. 34 to construct the narrow rip auxiliary fence (A13). **NOTE:** A11 should be cut to fit the length of the saw table top and sides (A14) must be parallel.

FIG. 34

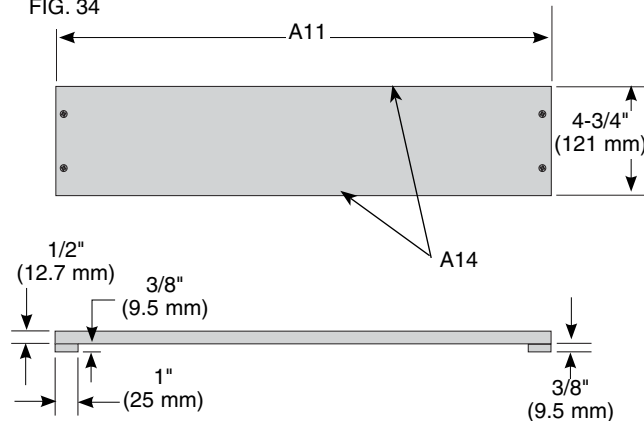

2. After the narrow rip auxiliary fence is constructed, slip it over the saw table top and place it flush to the fence as shown in Fig. 36.
3. Feed the workpiece through until the edge of the material reaches the front edge of the saw table top.
4. Continue feeding the material using the push block (A12) until the cut is complete.

Push Block (Fig. 35, 36)

IMPORTANT: Only use the push block (A12) with the narrow rip auxiliary fence, see **Narrow Rip auxiliary Fence**. The push block should be used once the material being cut reaches the saw table top.

1. Construct a push block using the diagram in Fig. 35.

NOTE: Edges (A15) must be the same size.

IMPORTANT: The over hanging edge (A16, Fig. 35) **MUST** be square. An uneven lip could cause the push block to slip or push the material away from the fence.

FIG. 35

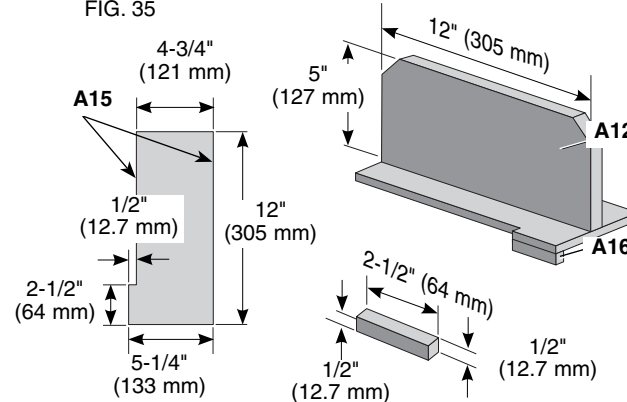

2. Place the push block (A12, Fig. 36) behind the material and ensure the lip of the block is flush to the narrow rip auxiliary fence (A13).
3. Once the push block is in place, continue feeding the material until the cut is complete making sure the push block remains flush to the narrow rip auxiliary fence at all times.

IMPORTANT: The narrow rip auxiliary fence and the over hanging edge (A16, Fig. 35) should both be the same thickness.

FIG. 36

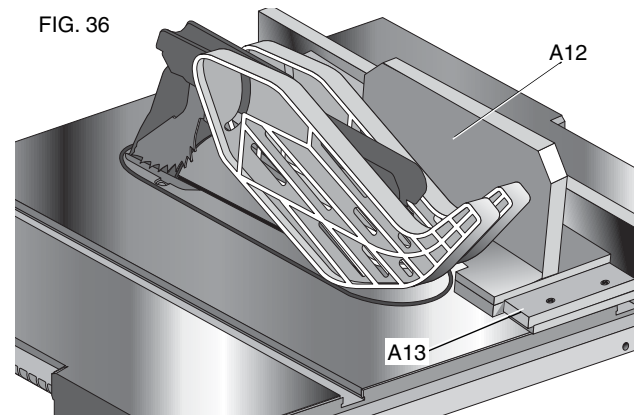

Bevel Ripping

This operation is the same as ripping except the bevel angle is set to an angle other than zero degrees.

⚠WARNING: Before connecting the table saw or operating the saw, always inspect the blade guard assembly and riving knife for proper alignment and clearance with saw blade. Check alignment after each change of bevel angle.

Crosscutting

⚠WARNING: NEVER touch the "free end" of the workpiece or a "free piece" that is cut off, while the power is ON and/or the saw blade is rotating. Piece may contact the blade resulting in a thrown workpiece and possible injury.

⚠WARNING: To reduce the risk of injury, **NEVER** use the fence as a guide or length stop when crosscutting.

⚠WARNING: NEVER use a length stop on the free end of the workpiece when crosscutting. In short, the cut-off piece in any through-sawing (cutting completely through the workpiece) operation must never be confined — it must be allowed to move away from saw blade to prevent contact with blade resulting in a thrown workpiece and possibly injury.

⚠WARNING: Use caution when starting the cut to prevent binding of the blade guard assembly against the workpiece resulting in damage to saw and possible injury.

⚠CAUTION: When using a cut-off gauge, the block must be at least 3/4" (19 mm) thick and is very important that the rear end of the block be positioned so the workpiece is clear of the block before it enters the blade to prevent contact with blade resulting in a thrown workpiece and possibly injury.

1. Remove the rip fence and place the miter gauge in the desired slot.
2. Adjust the blade height so that the blade is about 1/8" (3.2 mm) higher than the top of the workpiece.
3. Hold the workpiece firmly against the miter gauge with the path of the blade in line with the desired cut location. Keep the workpiece an inch or so in front of the blade. **KEEP BOTH HANDS AWAY FROM THE BLADE AND THE PATH OF THE BLADE** (Fig. 37).

FIG. 37

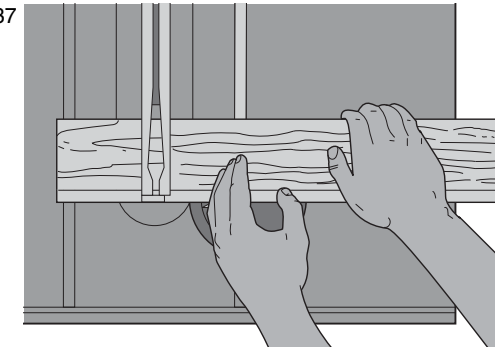

4. Start the saw motor and allow the blade to come up to speed.
5. While using both hands to keep the workpiece against the face of the miter gauge, and holding the workpiece flat against the table, slowly push the workpiece through the blade.
6. Never try to pull the workpiece with the blade turning. Turn the switch off, allow the blade to stop, and carefully slide the workpiece out.

CAUTION: Never touch or hold onto the “free” or “cut off” end of the workpiece.

Bevel Crosscutting

This operation is the same as crosscutting except that the bevel angle is set to an angle other than 0°. For proper hand position, refer to Figure 38.

FIG. 38

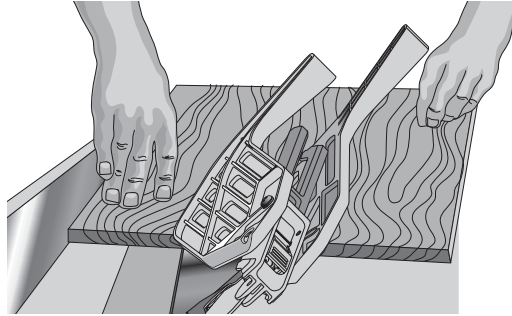

WARNING: Before connecting the table saw to the power source or operating the saw, always inspect the blade guard assembly and riving knife for proper alignment and clearance with saw blade. Check alignment after each change of bevel angle.

Mitering

WARNING: Miter angles greater than 45° may force the blade guard assembly into the saw blade causing damage to the blade guard assembly and personal injury. Before starting the motor, test the operation by feeding the workpiece into the blade guard assembly. If the blade guard assembly contacts the blade, place the workpiece under the blade guard assembly, not touching the blade, before starting the motor.

CAUTION: Certain workpiece shapes, such as molding may not lift the blade guard assembly properly. Feed the workpiece slowly to start the cut. If the blade guard assembly contacts the blade, place the workpiece under the blade guard assembly, not touching the blade, before starting the motor.

This operation is the same as crosscutting except the miter gauge is locked at an angle other than 0°. Hold the workpiece FIRMLY against the miter gauge (Fig. 39) and feed the workpiece slowly into the blade (to prevent the workpiece from moving).

FIG. 39

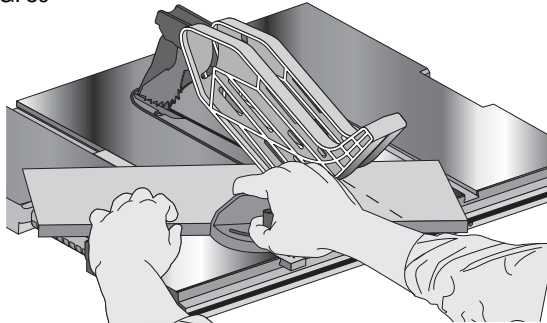

Miter Gauge Operation

To set your miter gauge, loosen the lock handle and move the miter gauge to the desired angle.

Compound Mitering

This is a combination of bevel crosscutting and mitering. Follow the instructions for both bevel crosscutting and mitering.

Dado Cutting

CAUTION: Do not attempt to stack dado blades thicker than 13/16" (20 mm). Do not use dado blades larger than 8" (200 mm) diameter. When installing the dado stack, do not include the inner clamp washer. Replace it with the outer clamp washer, then install the blade stack, arbor nut, and tighten with the wrench supplied.

Since dado cuts are not through cuts, the cuts must be performed with the blade guard assembly removed. To remove the blade guard assembly, lift guard lock lever (N) and remove (Fig. 15).

When using the dado, the special dado insert (also sold as an accessory) must be used.

Anytime a cut is required that is considerably wider than the saw kerf, a dado is used. A dado cut is commonly used to add support and line up a shelf for a cabinet, bookcase or some such project. **When using the dado, the blade guard assembly must be removed. Use EXTREME care when using the dado without the blade guard assembly and riving knife.** If a deep cut is required. Use several successive passes rather than attempting to make it with one pass. Maximum dado width on this saw is 13/16" (20 mm). DO NOT USE WIDER COMBINATIONS.

CAUTION: Always check dado blade clearance before plugging in the saw.

Be sure to place the blade guard assembly and standard throat plate back in position and check adjustments when the dado cuts are complete. Reinstall blade guard assembly, anti-kickback assembly and riving knife.

Featherboard Construction

Featherboards are used to keep the work in contact with the fence and table, and help prevent kickbacks. Dimensions for making a typical featherboard are shown in Figure 40. Make the featherboard from a straight piece of wood that is free of knots and cracks. Clamp the featherboard to the fence and table so that the leading edge of the featherboard will support the workpiece until the cut is complete (Fig. 41). An 8" (203 mm) high flat board can be clamped to the rip fence and the featherboard can be clamped to the 8" (203 mm) high board.

FIG. 40

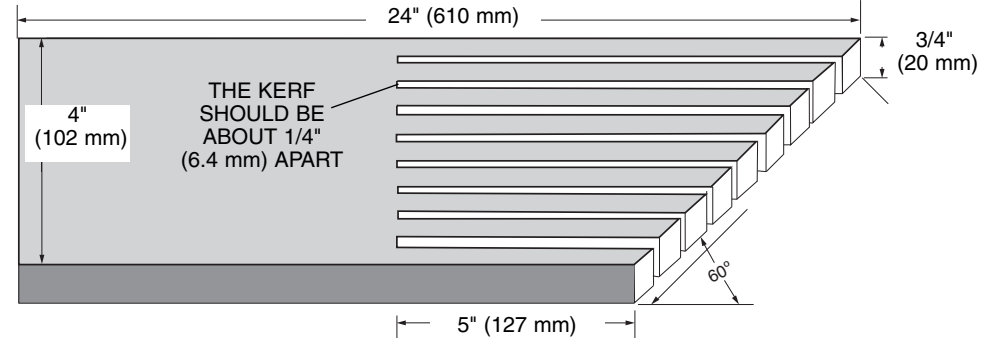

WARNING: Use featherboards for all non-thru-sawing operations where the blade guard assembly, anti-kickback assembly and riving knife cannot be used. **Always replace the blade guard assembly, anti-kickback assembly and riving knife when the non-thru-**

sawing operation is complete. Make sure the featherboard presses only on the portion of the workpiece in front of the blade.

FIG. 41

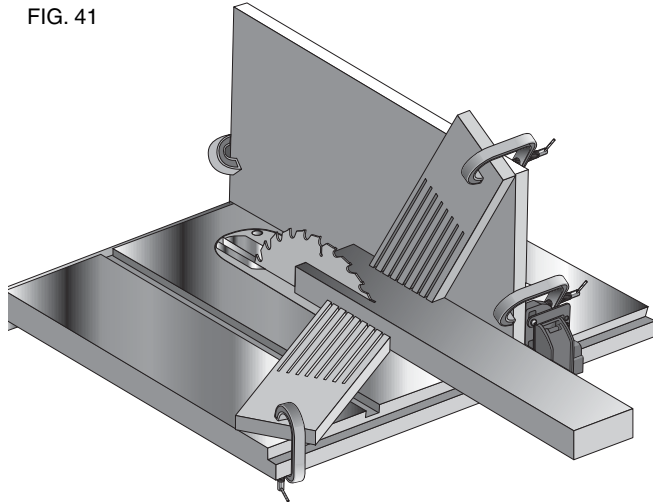

Dust Collection

Your table saw is equipped with a dust shroud and dust collection port. For best results, connect a vacuum to the port at the rear of the saw.

After extended use, the saw's dust collection system may become clogged. To clear the dust collection system:

1. Unplug the saw.
2. Turn the saw on its side, so the bottom, open part of the unit is accessible.
3. Open the dust access door (A4) shown in Figure 42 by removing the hair pin cotters (A5). Clean out the excess dust, and re-secure the access door with the cotters.

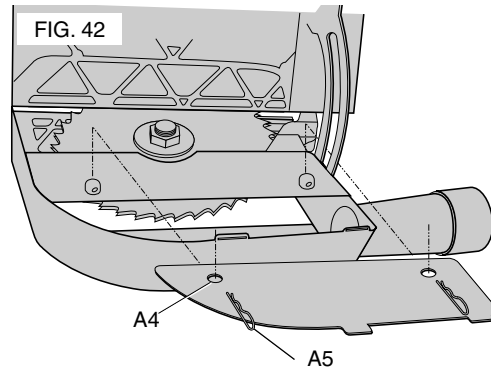

Motor Overload

WARNING: If power is interrupted by a circuit breaker trip, make sure the switch is in the OFF position before restoring power to prevent the saw from starting unexpectedly.

Circuit breaker overload is often the result of a dull blade. Change your blade on a regular basis to avoid tripping your breaker. Check your blade before re-setting the circuit breaker and continuing to saw.

Circuit Breaker Reset Button

This saw is equipped with a 25 amp circuit breaker (H). If this saw becomes overloaded and stops operating, turn off the saw, let the unit sit for two minutes and press the reset button before you resume working (Fig. 43).

FIG. 43

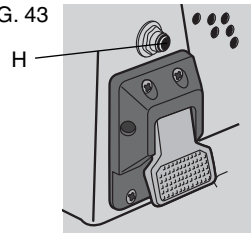

MAINTENANCE

WARNING: To reduce the risk of injury, turn unit off and disconnect machine from power source before installing and removing accessories, before adjusting or changing set-ups or when making repairs. An accidental start-up can cause injury.

Cleaning

WARNING: Blowing dust and chips out of the motor housing using clean, dry compressed air is a necessary regular maintenance procedure. Dust and chips containing metal particles often accumulate on interior surfaces and could create an electrical shock or electrocution if not frequently cleaned out. ALWAYS WEAR SAFETY GLASSES.

CAUTION: When cleaning, use only a damp cloth on plastic parts. Many household cleaners contain chemicals which could seriously damage plastic. Also, do not use gasoline, turpentine, lacquer or paint thinner, dry cleaning fluids or similar products which may seriously damage plastic parts. Never let any liquid get inside the tool; never immerse any part of the tool into a liquid.

Lubrication

1. All motor bearings are permanently lubricated at the factory and no additional lubrication is needed.
2. The height adjustment screw may require periodic cleaning and lubrication. If you have difficulty raising or lowering the blade:
 - a) Unplug the saw.
 - b) Turn the saw on its side, so the bottom, open part of the unit is accessible.
 - c) Clean and lubricate the height adjustment screws threads (A6) on the underside of your saw with general purpose grease, shown in Figure 44.

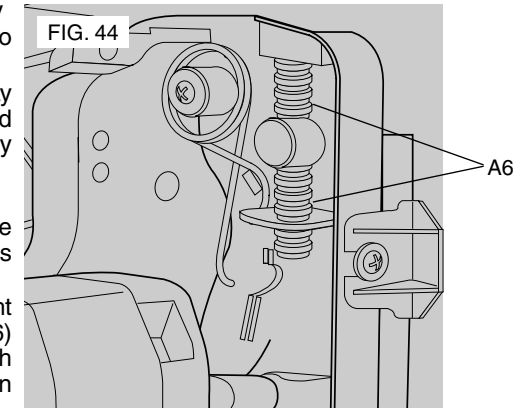

Accessories

WARNING: Since accessories, other than those offered by DEWALT, have not been tested with this product, use of such accessories with this tool could be hazardous. To reduce the risk of injury, only DEWALT, recommended accessories should be used with this product.

Recommended accessories for use with your tool are available at extra cost from your local dealer or authorized service center. If you need assistance in locating any accessory, please contact DEWALT Industrial Tool Co., 701 East Joppa Road, Baltimore, MD 21286, call 1-800-4-DEWALT (1-800-433-9258) or visit our website www.dewalt.com.

Repairs

To assure product SAFETY and RELIABILITY, repairs, maintenance and adjustment (including brush inspection and replacement) should be performed by a DEWALT factory service center, a DEWALT authorized service center or other qualified service personnel. Always use identical replacement parts.

STORAGE (Fig. 45)

1. Attach push stick (U) to fence.
2. Remove blade guard assembly. See **To Remove Blade guard assembly**. Slide blade guard assembly into brackets as shown.

FIG. 45

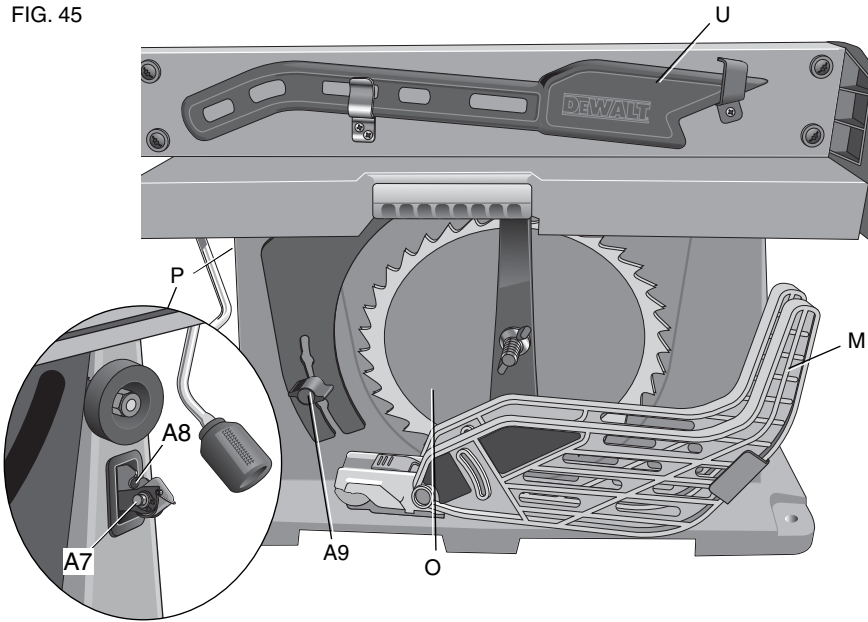

- Depress the stem (A7) on the anti-kickback assembly (P) to allow the assembly to slide from the riving knife slot.
- Position anti-kickback assembly into the storage hole as shown. While depressing stem (A7) slide the anti-kickback assembly across the storage slot (A8) and release pin to lock into place.
- Loosen the riving knife lock knob (YY, Fig. 6A) (minimum of three turns).
- Push riving knife lock knob (YY) toward the riving knife as indicated by the yellow arrows on the knob to disengage riving knife lock pin.
- Lift and slide the riving knife from saw.
- The riving knife can be stored on the fastener on the side of the unit. Place the riving knife center slot over the stud and secure with the lock knob (A9).

Three Year Limited Warranty

DEWALT will repair, without charge, any defects due to faulty materials or workmanship for three years from the date of purchase. This warranty does not cover part failure due to normal wear or tool abuse. For further detail of warranty coverage and warranty repair information, visit www.dewalt.com or call 1-800-4-DEWALT (1-800-433-9258). This warranty does not apply to accessories or damage caused where repairs have been made or attempted by others. This warranty gives you specific legal rights and you may have other rights which vary in certain states or provinces.

In addition to the warranty, DEWALT tools are covered by our:

1 YEAR FREE SERVICE

DEWALT will maintain the tool and replace worn parts caused by normal use, for free, any time during the first year after purchase.

90 DAY MONEY BACK GUARANTEE

If you are not completely satisfied with the performance of your DEWALT Power Tool, Laser, or Nailer for any reason, you can return it within 90 days from the date of purchase with a receipt for a full refund – no questions asked.

LATIN AMERICA: This warranty does not apply to products sold in Latin America. For products sold in Latin America, see country specific warranty information contained either in the packaging, call the local company or see website for warranty information.

FREE WARNING LABEL REPLACEMENT: If your warning labels (Fig. 46) become illegible or are missing, call 1-800-4-DEWALT (1-800-433-9258) for a free replacement.

FIG. 46

⚠ DANGER/PELIGRO

KEEP HANDS AWAY FROM BLADE.
MANTENGA MANOS LEJOS DE HOJA.
GARDER DES MAINS LOIN DE LA LAME.

⚠ WARNING TO REDUCE THE RISK OF INJURY, READ INSTRUCTION MANUAL BEFORE OPERATING SAW. ALWAYS USE PROPER EYE AND RESPIRATORY PROTECTION. DO NOT WEAR GLOVES, NECKTIES, JEWELRY OR LOOSE CLOTHING. CONTAIN LONG HAIR, KEEP HANDS OUT OF THE LINE OF SAW BLADE. USE EXTRA CAUTION WHEN BEVELING. USE SAW-BLADE GUARD AND RIVING KNIFE FOR EVERY OPERATION FOR WHICH IT CAN BE USED, INCLUDING ALL THROUGH SAWING. USE A "PUSH STICK" WHEN REQUIRED. KNOW HOW TO REDUCE THE RISK OF KICKBACKS - SEE MANUAL. ALWAYS SUPPORT WORK WITH TABLE AND FENCE OR MITER GAUGE. DO NOT PERFORM ANY OPERATION FREE HAND. USE FENCE WHEN RIPPING AND MITER GAUGE WHEN CROSS-CUTTING. NEVER USE TOGETHER. NEVER REACH AROUND OR OVER SAW BLADE. SECURELY MOUNT SAW BLADE BEFORE OPERATING. NEVER REMOVE JAMMED OR CUT-OFF PIECES UNTIL POWER IS OFF AND BLADE HAS STOPPED. LOCK BEVEL ADJUSTMENT BEFORE OPERATION. SECURE TOOL PROPERLY TO PREVENT UNEXPECTED MOVEMENT. DO NOT OPERATE THIS MACHINE WHILE UNDER THE INFLUENCE OF ALCOHOL OR DRUGS. FAILURE TO COMPLY WITH THESE WARNINGS MAY RESULT IN SERIOUS PERSONAL INJURY. DOUBLE INSULATED - WHEN SERVICING, USE ONLY IDENTICAL REPLACEMENT PARTS.

⚠ ADVERTENCIA PARA REDUCIR EL RIESGO DE LESIONES, LEA EL MANUAL DE INSTRUCCIONES ANTES DE OPERAR LA SIERRA. SIEMPRE UTILICE PROTECCIÓN ADECUADA PARA LOS OJOS Y LAS VÍAS RESPIRATORIAS. NO UTILICE GUANTES, CORBATAS, ALHAJAS NI ROPA SUELTA. SUJETE EL CABELLO LARGO, MANTENGA LAS MANOS FUERA DEL TRAYECTO DE LA HOJA DE LA SIERRA, TENGA MUCHO CUIDADO AL REALIZAR EL BISELAJO. UTILICE EL PROTECTOR DE LA HOJA DE LA SIERRA Y LA SIERRA CIRCULAR EN TODAS LAS OPERACIONES EN LAS QUE PUEDE, INCLUIDOS TODOS LOS CORTES CON SIERRA. USE UN "EMPULADOR" SIEMPRE QUE SEA NECESARIO. LEA EL MANUAL PARA OBTENER INFORMACIÓN SOBRE COMO REDUCIR EL RIESGO DE RETROCESOS. SOSTENGA SIEMPRE LA PIEZA DE TRABAJO CON UNA MESA Y UNA GUÍA O CALIBRADOR DE INGLETE. NO REALICE NINGUNA OPERACIÓN SIN UTILIZAR LAS MANOS. UTILICE LA GUÍA AL HACER CORTES LONGITUDINALES Y EL CALIBRADOR DE INGLETE AL HACER CORTES TRANSVERSALES. NUNCA USE AMBOS A LA VEZ. NUNCA INTENTE ALCANZAR ALREDEDOR O SOBRE LA HOJA DE LA SIERRA. CONECTE LA HOJA DE LA SIERRA CON SEGURIDAD ANTES DE OPERARLA. NUNCA CUOTE PIEZAS ATASCADAS O CORTADAS SIN QUE LA HERRAMIENTA ESTE ANCLADA Y LA HOJA SE HAYA DETENIDO. TRABE EL AJUSTE DEL BISEL ANTES DE USAR LA HERRAMIENTA. FUJE LA HERRAMIENTA CORRECTAMENTE PARA EVITAR QUE SE MUEVA INESPERADAMENTE. NO OPERE ESTA MÁQUINA SI ESTÁ BAJO LOS EFECTOS DEL ALCOHOL O DROGAS. EL INCUMPLIMIENTO DE ESTAS ADVERTENCIAS PODRÍA CAUSAR LESIONES PERSONALES, DOBLE AISLAMIENTO, AL DARLE SERVICIO UTILIZAR SOLO REPUESTOS IDENTICOS.

⚠ AVERTISSEMENT TOUJOURS UTILISER UNE PROTECTION OCULAIRE ET UNE PROTECTION RESPIRATOIRE ADEQUATES. NE PAS PORTER DE GANTS, NI CORBATAS, BIJOUX OU VETEMENTS AMPLES. ATTACHER LES CHEVEUX LONGS. TENIR LES MAINS LOIN DE LA TRAJECTOIRE DE LA LAME DE SCIE - ETRES TRÈS PRUDENT POUR LE BISEAUTAGE. UTILISER UN PARE-MAIN ET UN DISPOSITIF D'ECARTEMENT POUR TOUTES LES OPERATIONS DEMANDANT SON UTILISATION Y COMPRIS TOUT DÉBITAGE COMPLET. UTILISER UN "POUSSOIR" S'IL Y A LIEU. CONNAITRE LES TECHNIQUES POUR REDUIRE LE RISQUE ASSOCIE À L'EFFET DE REBOND - CONSULTER LE MODE D'EMPLOI. TOUJOURS SOUTENIR LA PIÈCE AVEC LA TABLE ET LE GUIDE OU AVEC LE GUIDE D'ONGLETS. EFFECTUER TOUTE OPERATION EN TENANT L'OUTIL DES DEUX MAINS. UTILISER LE GUIDE LONGITUDINAL POUR LE SCIAGE EN LONG ET LE GUIDE D'ONGLET POUR LE TRONÇONNAGE. NE JAMAIS UTILISER LES DEUX SYSTEMES SIMULTANÉMENT. NE JAMAIS SE PENCHER PRES DE LA LAME OU AU-DESSUS DE CELLE-CI. BIEN FIXER LA LAME DE SCIE AVANT D'UTILISER L'OUTIL. NE JAMAIS RETIRER UNE PIÈCE COMBEE OU COUPER TANT QUE L'OUTIL N'A PAS ETE MIS HORS TENSION ET QUE LA LAME N'A PAS CESSÉ DE TOURNER. VERROUILLER LE REGLAGE DU BISEAU AVANT UTILISATION. BIEN FIXER L'OUTIL. POUR EVITER TOUT DEPLACEMENT INATTENDU, NE PAS UTILISER CET OUTIL SOUS L'EMPRESSION D'ALCOHOL OU DE LA DROGUE. NE NEGLIGER DE SE CONFORMER A CES AVERTISSEMENTS RISQUE DE PROVOQUER DES BLESSURES GRAVES. A DOUBLE ISOLEMENT - N'UTILISEZ QUE DES PIÈCES DE RECHANGE IDENTIQUES POUR L'ENTRETIEN.

U.S. PAT. NO. 5,722,266; 5,857,507; 5,875,608; 5,927,857; 5,970,525; 6,148,703; 6,244,140; 6,357,328; D398,747; D394,071; D395,322; D397,344; D400,217; D407,725; D410,474; D414,786; D445,119 OTHER PATENTS PENDING.
DEWALT INDUSTRIAL TOOL CO., 701 EAST JOPPA ROAD, BALTIMORE MD, 21286 U.S.A.
FOR SERVICE INFORMATION, CALL 1-800-4-DEWALT www.dewalt.com

⚠ ADVERTENCIA PARA REDUCIR EL RIESGO DE UNA LESIÓN GRAVE, UTILICE EL CONJUNTO PROTECTOR DE LA HOJA Y LA GUARDA PARA CUCHILLA SIEMPRE QUE SEA POSIBLE, INCLUSO PARA TODOS LOS CORTES CON SIERRA. MANTENGA LAS MANOS FUERA DE LA LINEA DE LA HOJA DE LA SIERRA. UTILICE UNA VARA PARA EMPUJAR SIEMPRE QUE SEA NECESARIO.

⚠ AVERTISSEMENT POUR RÉDUIRE LE RISQUE DE BLESSURES GRAVES, UTILISER LE PROTEGE-LAME ET LE COUTEAU SEPARATEUR POUR TOUTES LES APPLICATIONS POSSIBLES Y COMPRIS LE DÉBITAGE COMPLET, GARDER LES MAINS HORS DE LA TRAJECTOIRE DE LA LAME DE LA SCIE. UTILISER UN POUSSOIR S'IL Y A LIEU.

⚠ WARNING TO REDUCE THE RISK OF SERIOUS INJURY, USE SAW BLADE GUARD AND RIVING KNIFE FOR EVERY OPERATION FOR WHICH IT CAN BE USED, INCLUDING ALL THROUGH SAWING. KEEP HANDS OUT OF THE LINE OF SAW BLADE. USE A PUSH-STICK WHEN REQUIRED.

⚠ WARNING FOR PROPER USE AND INSTALLATION OF GUARD, RIVING KNIFE AND KICKBACK PAWLS REFER TO INSTRUCTION MANUAL.

⚠ ADVERTENCIA PARA INSTALAR Y UTILIZAR CORRECTAMENTE EL PROTECTOR, LA CUCHILLA HENDEDORA Y LOS SEGUROS ANTIRRETROCESO, CONSULTE EL MANUAL DE INSTRUCCIONES.

⚠ AVERTISSEMENT SE REPORTER AU MODE D'EMPLOI POUR ADEQUATES DU PROTEGE-LAME, DU COUTEAU SEPARATEUR ET DES CLIQUETS ANTI-EFFET DE REBOND.

⚠ WARNING USER MUST READ INSTRUCTION MANUAL FOR PROPER INSTALLATION OF ANTI-KICKBACK ASSEMBLY.

⚠ ADVERTENCIA EL USUARIO DEBE LEER EL MANUAL DE INSTRUCCIONES PARA UNA CORRECTA INSTALACIÓN DEL CONJUNTO DE ANTIRRETROCESO.

⚠ AVERTISSEMENT L'UTILISATEUR DOIT LIRE LE MODE D'EMPLOI POUR CONNAITRE LE BON MODE D'INSTALLATION DU MODULE ANTIRECUL.

Push Stick Pattern
Modèle de poussoir
Patrón de la vara de empuje

Adjust length of push stick so hand will clear blade guard and rip fence.

Régler la longueur du poussoir de sorte que la main sera dégagée du protège-lame et du guide longitudinal.

Ajuste el largo de las varas de empuje para que la mano no obstruya el protector de la hoja y la guía de corte longitudinal.

CAUTION: Make push stick from plywood or softwood equal to or less than the width of the material to be cut.

ATTENTION : fabriquer le poussoir à partir de contreplaqué ou de bois tendre de la même largeur ou un peu moins large que la pièce à couper.

ATENCIÓN: fabrique varas de empuje de madera contrachapada o madera blanda cuyo ancho sea igual o menor que el ancho del material que desea cortar.

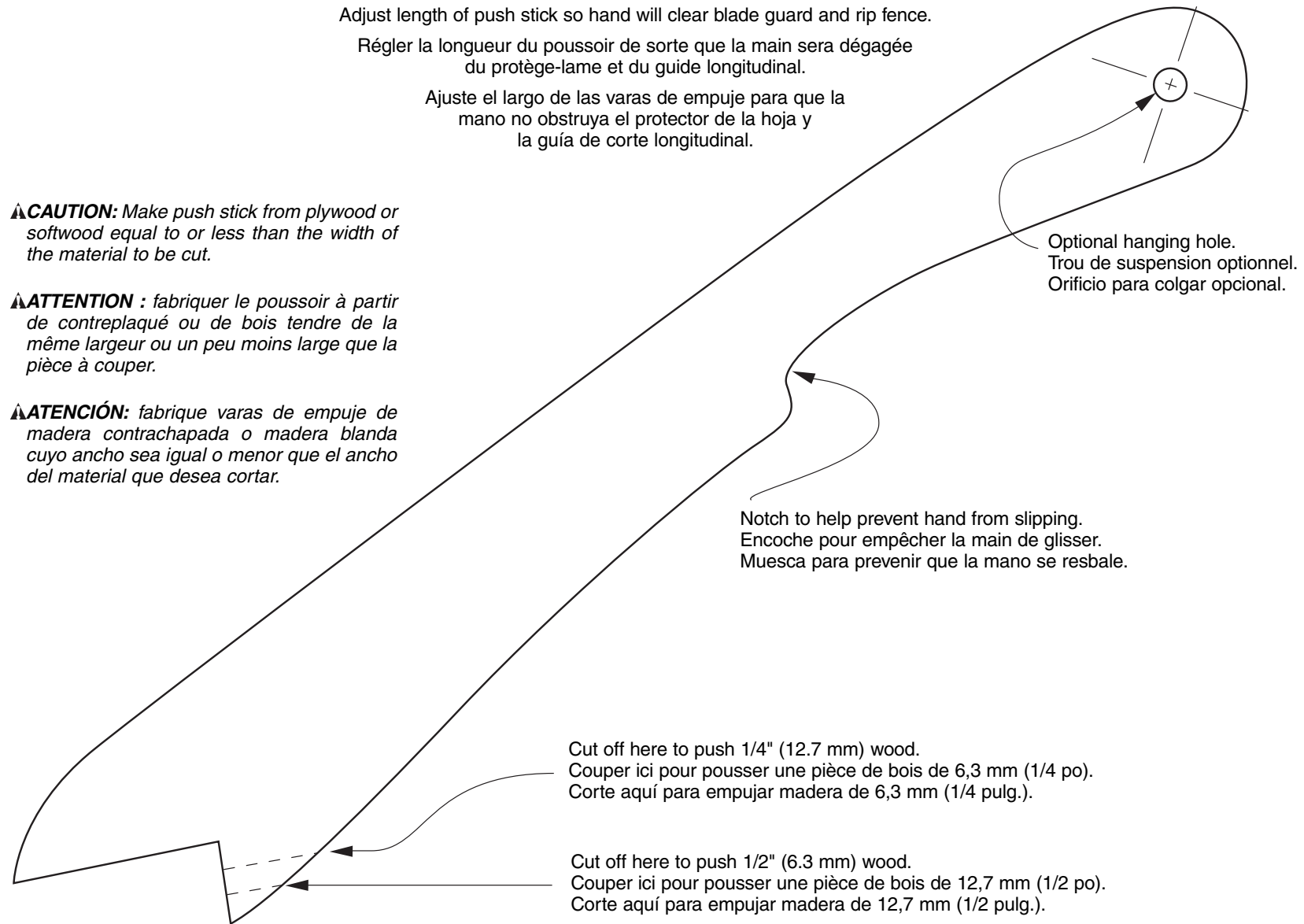

DEWALT Industrial Tool Co., 701 Joppa Road, Baltimore, MD 21286

(JAN11) Part No. N104913 DW744 Copyright © 2002, 2004, 2006, 2008, 2011 DEWALT

The following are trademarks for one or more DEWALT power tools: the yellow and black color scheme; the "D" shaped air intake grill; the array of pyramids on the handgrip; the kit box configuration; and the array of lozenge-shaped humps on the surface of the tool.