

SYLVANIA 4" LED Recessed Kit (RT4)

Installation Instructions

The SYLVANIA LED recessed kit RT6 is designed to install in standard 6" insulated and none-insulated recessed downlight housings. For a list of compatible housings, please refer to www.SYLVANIA.com/LEDdownlight.

The RT6 LED recessed kit can be dimmed, however updates on dimmer technology and special conditions may apply depending on dimmer type being used. To be assured of the latest information regarding recessed kit and dimmer compatibility, please reference www.SYLVANIA.com/LEDdownlight to find the latest list of compatible dimmers when used multiple RT6 recessed kits.

Note: It may be necessary to remove a socket mounting plate for adequate clearance in the compatible housing. Each lampholder shall be installed only in its intended manner and orientation. Not all existing recessed housings that meet this requirements will be compatible with the SYLVANIA RT6. To ensure compatibility, a test installation should be conducted.

Minimum distance between edge of recessed kit and top of the housing or other obstruction.

Figure 1 – Show image of 4" recessed can – see example

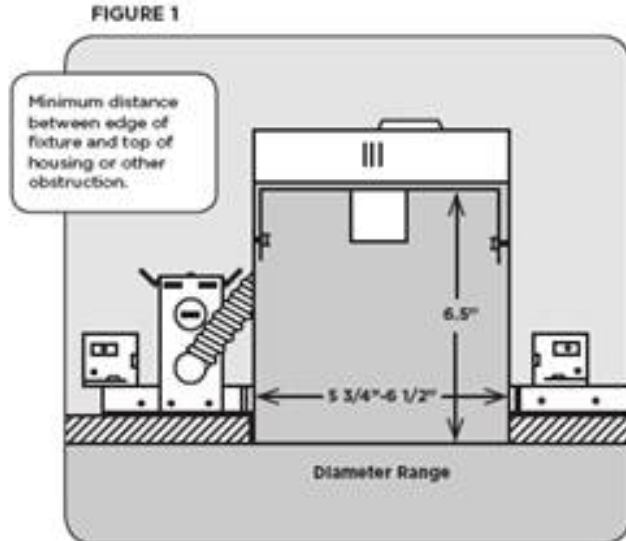

How to install

Important Safety information - read all instructions before installation.

Step 1: Remove mounting bracket and plate from inside existing recessed housing (if installed).

Step 2 : Remove socket from plate.

Step 3: Screw Edison base adaptor into socket in recessed housing (figure 2 – show image of the adaptor and how the medium base fits into the socket inside the recessed housing)

Step 4: Plug Edison base cable connector into the LED recessed kit (figure 3 - show image of where the connector goes into the RT6)

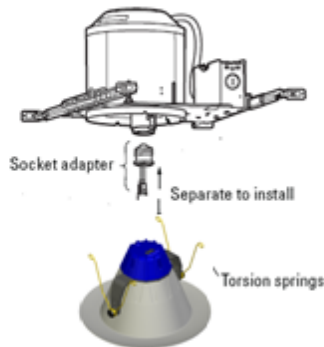

Step 5: Squeeze torsion springs together as shown and install into torsion spring brackets inside recessed housing (figure 4 – show image of the RT6 and it's torsion springs)

Step 6: Carefully route wires into fixture and push recessed kit up flush to ceiling surface. Show similar image

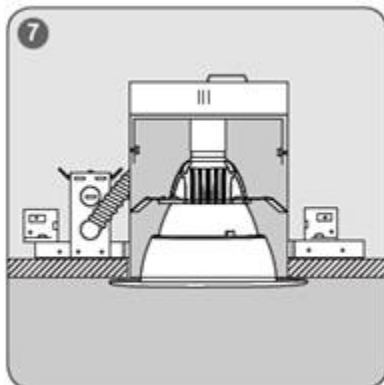

GU24 Installation

For California Title 24 Compliance (with existing GU24 socket), cut off wires from the housing base as well as wires from the adaptor. Then splice the cable connector leads to the base leads. Continue Step 5 and 6 shown above. (show image : showing cut wires and splice the housing wires and adaptor wires together)

Warranty Statement

Osram Sylvania Products Inc. warrants each LED recessed kit to be free from defects in materials and workmanship, and to operate from the date of installation (or date of manufacture if installation date is not known or available or verifiable) for a period of three (3) years. If an LED recessed kit fails to operate for the specified warranty period, Osram Sylvania Products Inc. will provide a free replacement component in accordance with the Terms and Conditions set forth below (labor is not included).

TERMS AND CONDITIONS

This warranty only applies when Osram Sylvania Products Inc. LED recessed kits are properly wired and installed, in accordance with the parameters specified in the applicable product information bulletin, used in lighting equipment designed and approved for the application and in environmental conditions (temperature, humidity) within the normal specified operating range of the system. This warranty does not apply to any abnormal use or use in violation of any applicable standard, code or instructions for use in installations including those contained in the latest National Electrical Code (NEC), the Standards for Safety of Underwriters Laboratory, Inc. (UL), Standards for the American National Standards Institute (ANSI) or, in Canada, the Canadian Standards Association (CSA). This warranty will not apply in the event of conditions demonstrating abnormal use or stress, including under/over voltage/current conditions, excessive switching cycles or operating hours or outside the following recommended operating conditions:

- Warranty Period is based on typical 8,760 hr/yr operation on a continuous burning cycle of 24 hours
- Do not exceed a 40°C ambient operating temperature
- Do not exceed the Tc point temperature specified in the applicable LED Module product specifications

WARRANTY ACTIVATION / SERVICE CLAIMS

Warranty claims can be serviced by calling Osram Sylvania Products Inc. National Customer Service & Sales Center:

1-800-654-0089

Fax: 866-632-9674

Email: warranty.service@sylvania.com

If you are unsure whether a situation exists that is covered by this warranty, please contact OSPI's National Customer Service & Sales Center for assistance.

RETURN OF DEFECTIVE PRODUCT

After contacting Osram Sylvania Products Inc., the purchaser/user shall promptly return the product after receiving instructions regarding if, when and where to ship the product. Failure to follow this procedure shall void this warranty. Osram Sylvania Products Inc. reserves the right to examine all failed Osram Sylvania Products Inc. LED Modules to determine the cause of failure and patterns of

usage and reserves the right to be the sole judge as to whether any of these components are defective and covered under this warranty.

LIMITATION OF LIABILITY

The foregoing shall constitute the exclusive remedy of the purchaser and the sole liability of Osram Sylvania Products Inc. for Osram Sylvania Products Inc. LED recessed kit. No warranty of merchantability or fitness for a particular purpose is made or is to be implied. In no event shall OSPI be liable for any other costs or damages, including lost profits or revenues, incidental, special or consequential damages.