

INSTALLATION INSTRUCTIONS

CAUTION: This product has sharp metal edges that can cut your hands. Wear canvas gloves during installation and handling. Use care when handling this unit to prevent damage to the precision-balanced rotor head.

Roof Cutout

Decide where to place turbines then from inside the attic, drill a hole 18" to 30" down from the roof peak and midway between the rafters. Put a stick up through the hole to locate it from outside. Go back on the roof and mark a hole 12" in diameter for a 12' turbine or 14" in diameter for a 14' turbine with the drilled hole at its center. Saw the hole through the sheathing and shingles with a keyhole saw or saber saw. Make a mark on the shingles 5-1/2" uproof from the top of the cutout and 5-1/2" to the right and left of it. (See Figure 1)

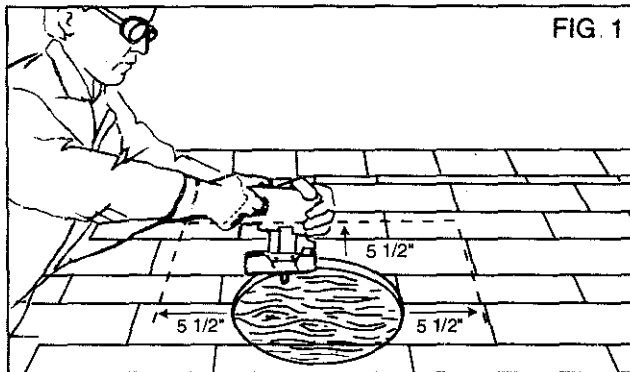

Shingle Preparation

Starting with the downroof edge of the single course of shingles closest to the horizontal centerline of the circular roof cutout, carefully roll upward all shingles in the area defined by the marks made in step 1. Completely remove all shingle nails in this area which become exposed by rolling up the shingles. (See Figure 2)

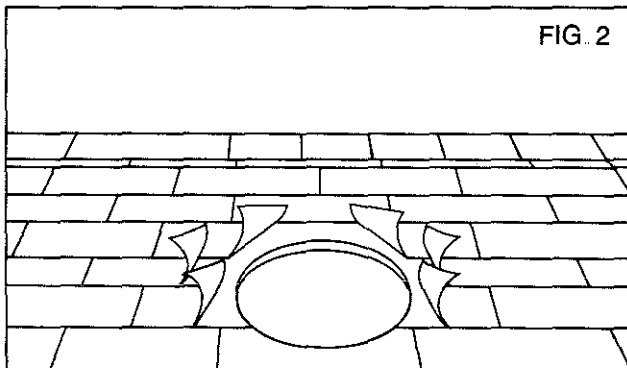

Base Attachment

Determine orientation, coat the underside of the base flashing with sealant, then carefully slide the upper half of the base flashing under the shingles previously rolled back until base is centered over the circular cutout.

Recheck alignment, then roll back shingles again and secure the base to the roof with a minimum of eight Ring Shank Roofing nails, equally spaced, located approximately 1 1/2" from the stack base. Use nails long enough to penetrate through roof sheathing a minimum of 1/2". Apply sealant to underside of shingles previously rolled back, then press them back into place over base flashing. Make sure shingles are properly secured, then secure down the lower portion of the base flashing which is not covered by shingles with at least four nails about 1/2" to 1" in from the edge of the flashing and equally spaced around the edge of the exposed flashing. (See Figure 3)

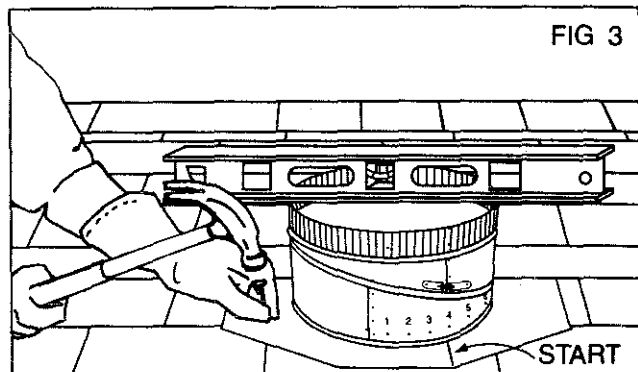

Transition Attachment

Determine roof pitch as described on reverse, then set the Transition Piece onto the base, making sure the hole marked with the proper roof pitch is aligned with the start line. Attach the transition to the base with three sheet metal screws (min size #10 x 1/2"). Loosen the clamp and turn the upper portion of the transition piece until the top is horizontal as determined with a carpenter's level. Now re-tighten the clamp. (See Figure 3)

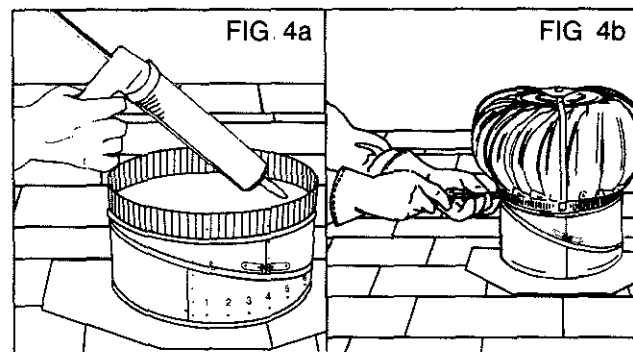

Sealing the Unit

Use sealant to seal the internal seams of the sliding junction between upper and lower sections. (See Figure 4a) Now slide the turbine head unit onto the crimped portion of the transition piece and secure with three sheet metal screws (min size #10 x 1/2"). Now seal external seams with sealant at upper and lower transition joints, vertical seam, and all exposed nail heads. (See Figure 4b)

Turbine Aire™ Wind Turbine

Preparation and Installation Guide for 12" & 14" Turbine Ventilators with Two Piece Adjustable Base

WARNING: This product has sharp metal edges that can cut your hands. Wear canvas gloves during installation and handling. Use care when handling this unit to prevent damage to the precision-balanced rotor head.

This Turbine is for ventilating purposes only and under NO circumstances should it be installed on a chimney or other hot stack or vent as a draft inducer: The heat will quickly damage the bearings and your Turbine will be ruined.

Tools for Installation

| | |
|------------------|----------------|
| Screwdriver | Utility Knife |
| Carpenters Level | Drill |
| Keyhole Saw | Hammer |
| or Saber Saw | Ruler |
| Putty Knife | Gloves |
| Sealant | Safety Glasses |

Sizing and Location

For maximum efficiency of operation, the ventilator should be fully exposed to prevailing winds and as high on the roof as possible. Avoid locating it behind parapets and it should be well to windward of any neighboring tall buildings or trees. Determine the number of turbines needed from the table below then measure the length of the roof (at the peak) and locate the turbines at equal spaces along the span.

For best service your Air Vent turbine ventilators must be used with proper intake vents such as Soffit or Undereave Vents. For 12" turbines, use 260 sq in. of net intake ventilation area for each turbine installed. For 14" turbines use 340 sq in.

How many turbines? Air Vent recommends:

| No. of Turbines | | Attic Area | |
|-----------------|-------|-------------|-------------|
| | | 12" Turbine | 14" Turbine |
| 1 turbine | up to | 600 sq ft | 700 sq ft |
| 2 turbines | up to | 1,200 sq ft | 1,400 sq ft |
| 3 turbines | up to | 1,800 sq ft | 2,100 sq ft |
| 4 turbines | up to | 2,400 sq ft | 2,800 sq ft |

Finding your Roof Pitch

Use Pitch Finder Gauge included in your package. Set the Pitch Finder Gauge on the roof with the arrow at the peak. Use a straight edge on the other side of the roof and read out the pitch at the lower side of the straight edge. Use this pitch number to set the turbine transition piece on to the base as described on the reverse side of this paper.

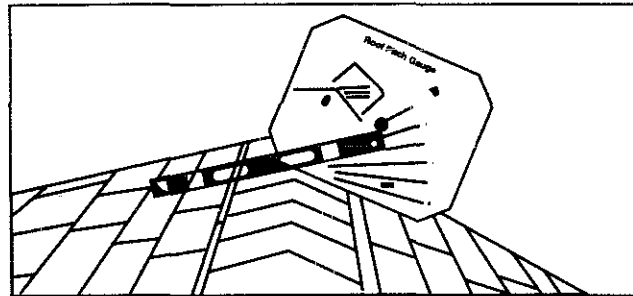

A Properly Vented Attic Must Have Intake AND Exhaust Ventilators.

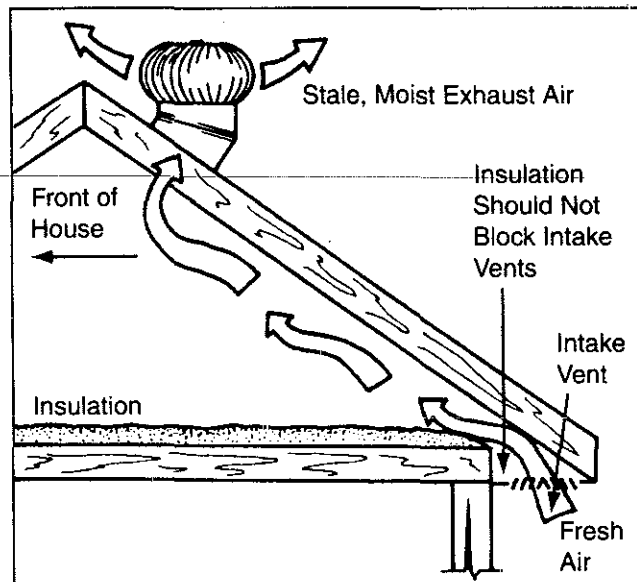

IMPORTANT! Do not cover wind turbines in colder weather. Turbine vents help remove damaging moisture present in attics all year round. If this moisture is not removed, it could cause mold, mildew and wood rot.

AIR VENT INC.
A GIBRALTAR INDUSTRIES COMPANY

4117 Pinnacle Point Drive
Suite 400
Dallas, Texas 75211

SEE OTHER SIDE FOR COMPLETE INSTALLATION INSTRUCTIONS