

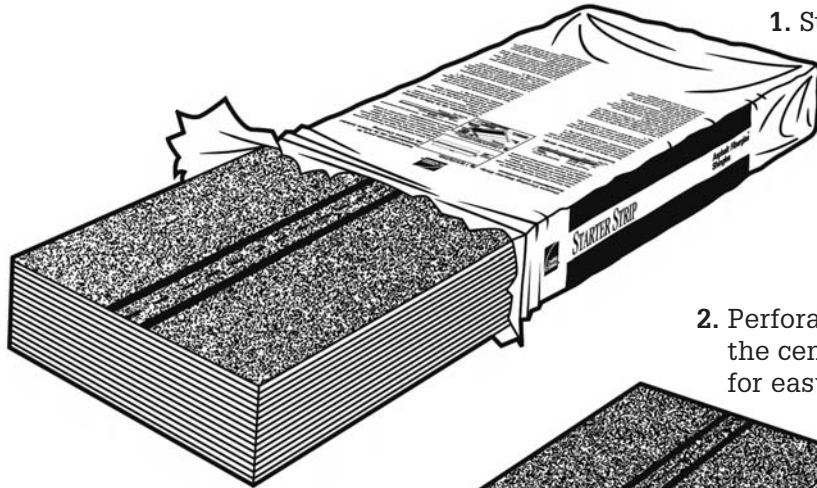

# Starter Strip Shingle

Goes on right—right away

Introducing the new Starter Strip shingle from Owens Corning™ Roofing—a world leader in building materials. This product eliminates the need for cutting shingle tabs to create a starter row.



1. Starter Strip is packaged two pieces per shingle, 16 shingles per bundle, 100 lineal feet.

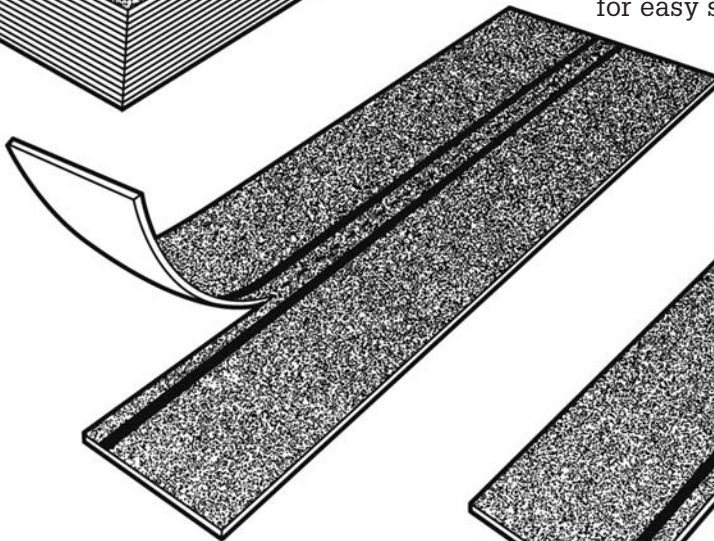

2. Perforation down the center allows for easy separation.

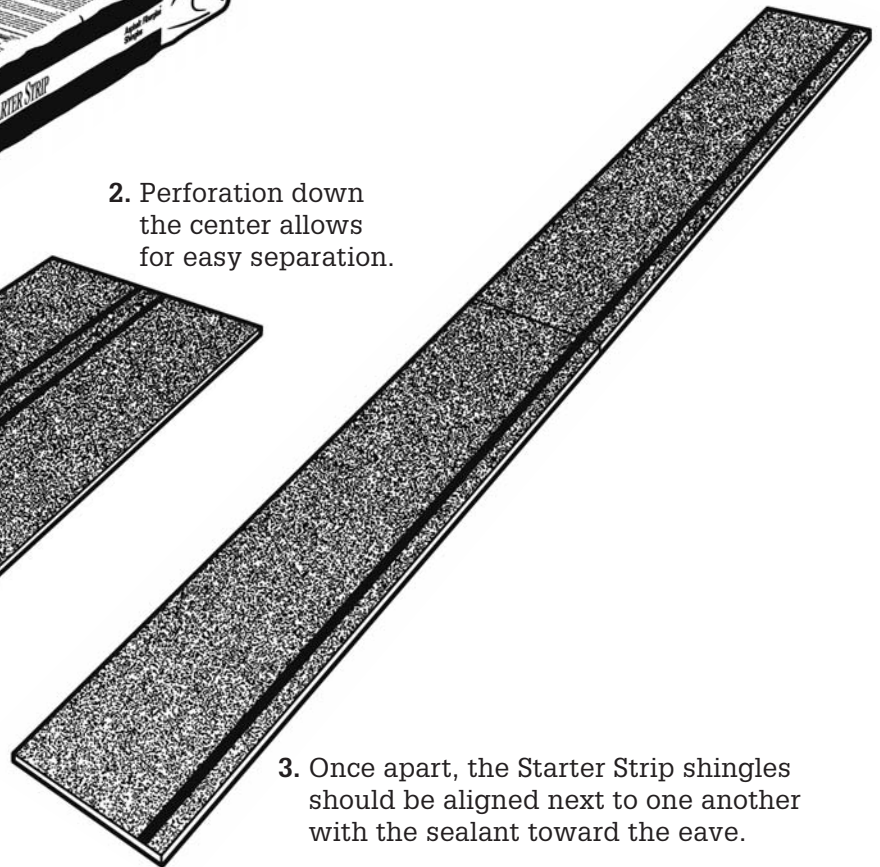

3. Once apart, the Starter Strip shingles should be aligned next to one another with the sealant toward the eave.

## Starter Strip shingle advantages:

**Speeds installation and helps improve safety.**

Starter Strip shingle eliminates the need to cut off tabs or headlap.

**Saves labor.** It's easy for a single person to position Starter Strip shingle on the roof.

**Maximum compatibility.** Use with any shingle that has an exposure of up to 6".

**Improves job quality.** Puts the sealant appropriately at the eaves.

**Cost savings.** There's no need to cut down field shingles to use as a starter strip.

**Clean look.** Starter Strip shingle provides a straight edge at the eave and along the rake.

**Exceptional bonding strength.** Continuous sealant ensures an effective seal between the starter and the first course of shingles.

## Application Instructions

Owens Corning™ Starter Strip can be used with any shingle that has an exposure of up to 6". Starter Strip shingles cannot be used with Owens Corning™ Berkshire®, Woodmoor®, Woodcrest® or WeatherGuard® HP shingles.

### Installation of Starter Strip shingle

Starter Strip shingle is designed to be broken into two pieces, and each piece has its own sealant strip. When separated, each starter shingle is 6<sup>5</sup>/<sub>8</sub>" x 39<sup>3</sup>/<sub>8</sub>", and each bundle will cover approximately 100 lineal feet. See Fig. 1.

This starter can be used with shingles that have an exposure of no more than 6"; if the exposure is greater than 6", a full starter (13<sup>1</sup>/<sub>4</sub>" x 39<sup>3</sup>/<sub>8</sub>") would be required. See Fig. 1.

1. Start first Starter Strip shingle with 6" removed from the rake edge and flush with the drip edge. Starter shingle can extend no greater than 3/4" beyond the edge of the eave. Use 5 fasteners placed 2" to 3" from the edge of the eave. See Fig. 2.
2. During application, the installer must ensure that when the starter is applied, the overlaying shingles' end joints do not line up with the starter end joints. End joints must be a minimum of 4" from the overlaying shingle.
3. When the starter is used with 3-tab shingles, the installer must ensure that nails in the starter are not exposed between the cutouts of the overlaying shingle.

## Product Specifications

<b>Size</b>	13 <sup>1</sup> / <sub>4</sub> " x 39 <sup>3</sup> / <sub>8</sub> " (337 mm x 1000 mm)
<b>Piece Size</b>	6 <sup>5</sup> / <sub>8</sub> " x 39 <sup>3</sup> / <sub>8</sub> " (168 mm x 1000 mm)
<b>Shingles per Bundle</b>	16
<b>Pieces per Bundle</b>	32 (6 <sup>5</sup> / <sub>8</sub> " x 39 <sup>3</sup> / <sub>8</sub> " [168 mm x 1000 mm])
<b>Lineal Feet per Bundle</b>	Approximately 100 (30.5 m)

## Applicable Standards and Codes

ASTM D 3462
UL 790, Class A
ASTM D 3161, Class F

**Fig. 1** Starter Strip Shingle

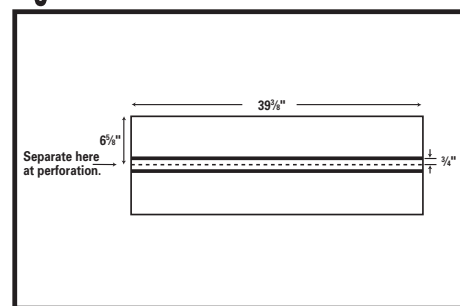

**Fig. 2** Starter Strip Shingle Application

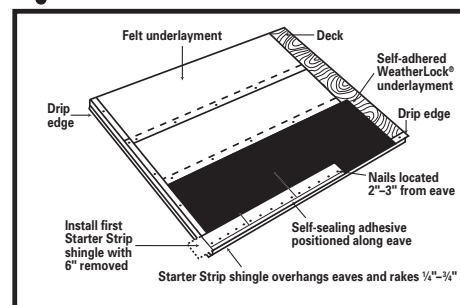

### Caution

#### Roof surface may be slippery:

Especially when wet or icy. Use a fall protection system when installing. Wear rubber-soled shoes. Walk with care.

**Falling hazard:** Secure area below work and materials on roof. Wear a hard hat.

### Notice

It is important that attic space be properly ventilated to maintain product performance and to prevent damage from moisture condensation and excessively high attic temperatures. In this regard, FHA and National Building Code Minimum Property Standards must be met.



**OWENS CORNING ROOFING AND ASPHALT, LLC**  
 ONE OWENS CORNING PARKWAY  
 TOLEDO, OHIO, USA 43659  
**1-800-GET-PINK®**  
[www.owenscorning.com](http://www.owenscorning.com)

Pub. No. 10004070-F. Printed in U.S.A. November 2010. THE PINK PANTHER™ & ©1964-2010 Metro-Goldwyn-Mayer Studios Inc. All Rights Reserved. The color PINK is a registered trademark of Owens Corning. ©2010 Owens Corning.

(Compton, Denver, Houston, Irving, Memphis, Portland)

