

*American
Standard*

SKU: 463780 / QK019

Owner's Manual

Stainless Steel Sink Work Center

With Portable Sink, Colander
and Cutting Board



THANK YOU

for selecting American Standard... the benchmark of fine quality for over 100 years. To ensure that your installation proceeds smoothly, please read these instructions carefully before you begin.

ATTENTION:

Carefully check the unit prior to installation to ensure there is no damage. Do not dispose of any packaging until you are satisfied with this product.

1. Your installation must comply with all local plumbing building codes. Have a qualified tradesman do or approve your plumbing installation.
2. Please read and save this guide before using this product. Store the guide in a safe place so you will know where it is when you want to refer to it.

WARNING: Always wear safety goggles and gloves in order to avoid any personal injuries.

Parts List

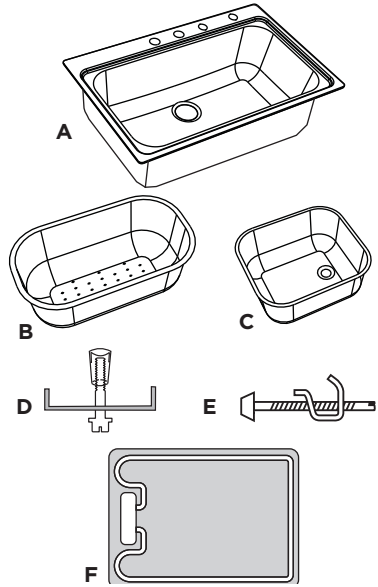

[A] Stainless steel sink.....	1 pc
[B] Colander	1 pc
[C] Sliding sink.....	1 pc
[D] Undermount clamps	10 pcs
[E] Topmount clamps	10 pcs
[F] Bamboo cutting board.....	1 pc

Tools and Materials Required

Tape measure
Carpenter's square
Pencil
Saber-saw/Jig-saw
Electric drill with 0.375 in (10 mm) drill bit
Pipe wrench
Phillips screwdriver
Plumber's putty
Silicone sealant
Masking tape

Topmount Installation

Topmount sinks are dropped into the counter from above. If you are installing an undermount sink, please see Undermount Installation on page 5.

NOTE: These instructions are for cutting Formica countertops only. Contact your countertop distributor for the best method of cutting other materials such as marble, hard synthetics, etc.

NOTE: Check very carefully that the sink will cover all of the area traced for cutout.

NOTE: Minimum countertop thickness is 0.75 in. (19 mm).

REPLACEMENT SINK

If this sink is a replacement sink, ensure that the cutout in your counter top is 32.25 in. x 21.25 in. (81.9 cm x 54 cm) with rounded corners, as shown in the diagram below.

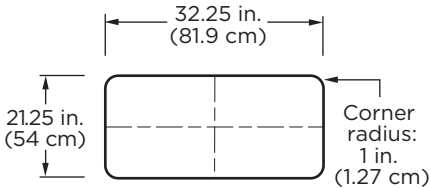

NEW INSTALLATION

1. If this sink is being installed in a new counter top, place the sink upside down on the counter top. Centre the sink left to right on the cabinet, making sure that it will not interfere inside with the structure of the cabinet or the counter top. The unit should be placed so that it is parallel to the front of the counter top and clears the overhang of the counter top and the front INSIDE face of the cabinet.

2. Trace the outline of the sink.
3. Draw a new line 0.375 in. (9.5 mm) inside the outline. This will be the cut line. The size of the cut line should be 32.25 in. x 21.25 in. (81.9 cm x 54 cm). The cut line is smaller than the size of the sink and must have rounded corners. Do not cut the opening with square corners.

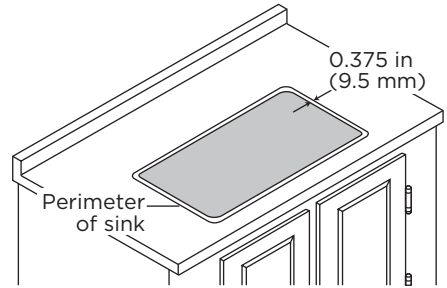

4. Using a 2 inch (51 mm) hole saw, carefully drill four corner holes inside the cut line. Use a saber-saw or jig-saw to cut along the cut line. Place a support underneath the cutout portion of the counter top to prevent it from falling during cutting.

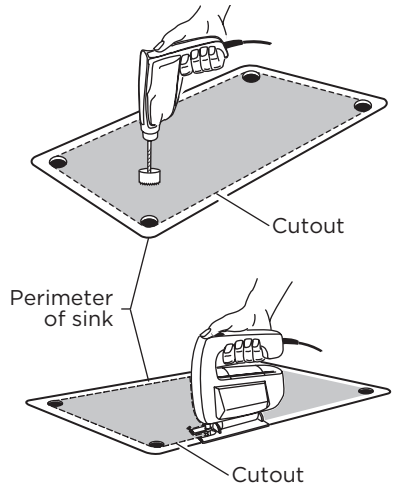

5. Insert the sink into the hole in the counter top to test the fit. Make adjustments to the hole, if necessary.

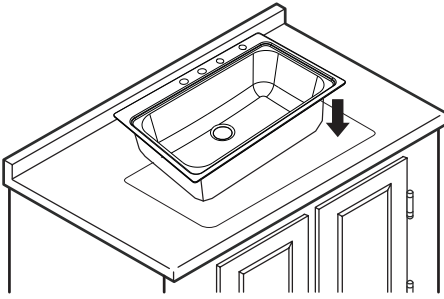

6. Apply silicone sealant around the underside rim of the sink on all four sides.

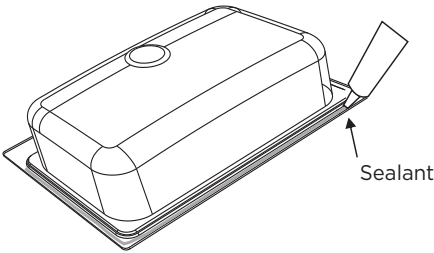

7. Carefully lower the sink into the counter top, ensuring the factory installed topmount clamps do not catch the countertop edges. Slide each clamp along the rails so they are evenly spaced around the sink front, back and sides.

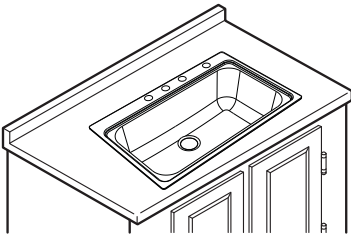

8. Swing the topmount clamps and tighten the screws progressively until the sink rim is flush with counter top. Check the alignment several times as you tighten, to make sure that the front of the sink is parallel to the front of the countertop. Adjust and re-tighten, if necessary. Do not over tighten.

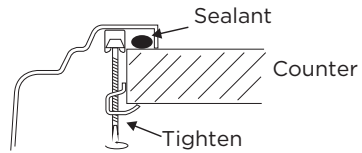
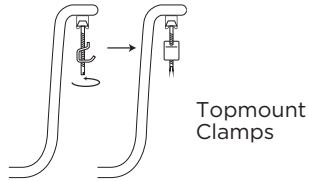

Tightening Sequence For Clips

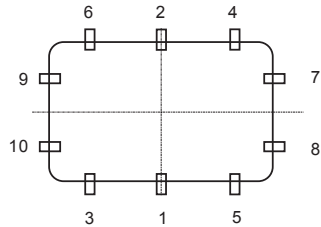

9. Wipe off excess sealant with a rag.

Undermount Installation

Undermount sinks are sinks that are mounted from below the countertop. If you are installing a topmount or “drop-in” sink, please see Topmount Installation on page 3.

NOTE: It is highly recommended that undermounting be performed by a professional installer. Improper installation will void the warranty.

NOTE: Minimum countertop thickness is 0.75 in. (19 mm). In addition, a 1 in. (2.54 cm) build up around the sink is preferred.

The instructions that follow are for installing the undermount stainless steel sink in a solid surface countertop only. Requirements vary for installation in a granite, marble, stone or butcher block countertop. Please contact your fabricator for specific details.

The overall dimensions of this sink are 33 in. x 22 in. (83.8 cm x 55.9 cm). The flat mating surface that will touch the underside of your counter top is 0.75 in. (1.9 cm) wide. We suggest you use a cutout size as noted: 31.5 in. W x 20.5 in. D (80 W cm x 52 cm D) giving zero reveal.

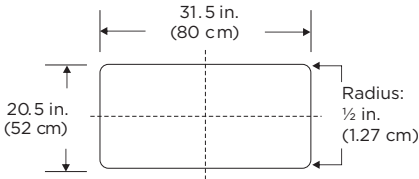

1. Using a framing square, draw a line from front to back on the bottom of the countertop, indicating the location of the center of the sink. Draw a line parallel to the front edge of the countertop, indicating how far back the sink should be located. Typically the setback is 3 in. to 3.5 in. (7.6 cm to 8.9 cm) from the front of the counter, depending on the countertop overhang, the type of sink bowl and the deck size.
2. Using cardboard or paper, draw a rectangle with rounded corners 31.5 in. x 20.5 in. (80 cm x 52 cm). Mark the center point of the sink on the template.

3. Cut out the template.
4. Center the template on the countertop, ensuring that the sink will clear all objects. It is suggested this sink be used in a 36 in. (91.4 cm) cabinet or larger to avoid interferences.

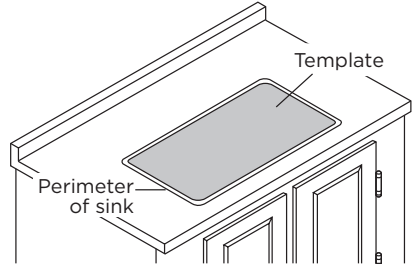

5. Place a line of masking tape on the countertop around the sink cutout area, on which you may trace the template. Ensure the template is parallel to the countertop front with the correct amount of setback for the mounting hardware to be installed.
6. Trace the template onto the masking tape and double check the location.
7. Using the proper tools specified by the countertop manufacturer, cut and remove the cutout, following the manufacturer's instructions.

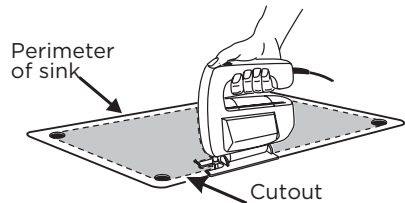
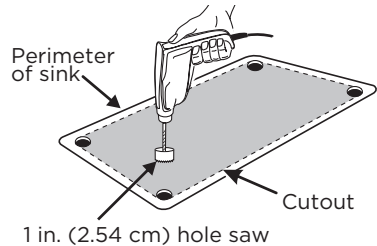

8. On the underside of the countertop, mark and drill 10 holes, 0.375 in. (10 mm) in diameter and 0.6 in. (1.52 cm) deep for the threaded inserts provided. The location of these holes should be equally spaced around the perimeter of the cutout (3 front and back, 2 each side) and should be set back 1.375 in. (3.5 cm) from the cutout opening.

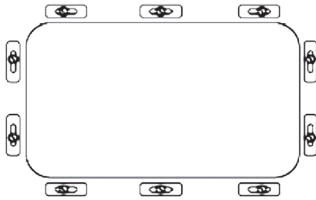
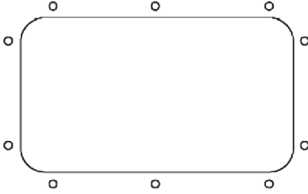

9. Test fit the sink underneath the countertop cutout. Ensure that the reveal is equal on all four sides, when viewed from above. Mark this location using a pencil to scribe the edge of the sink lip on at least two sides.

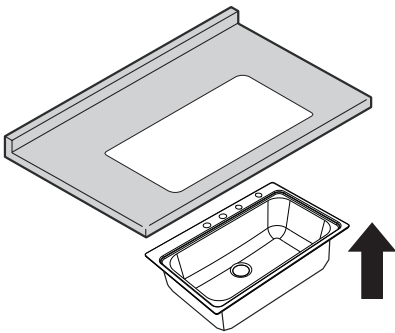

10. Install the threaded inserts, clamps, and bolts loosely. Ensure that the undermount clamps are turned as to not interfere with the final sink placement.

11. Place a small bead of silicone sealant around the outside perimeter of the sink and carefully place it into its final location, using the scribe marks made above.

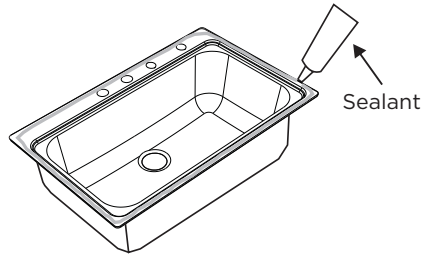

12. Carefully rotate the undermount clamps over the clamp bar on the sink and gently tighten, working from side to side to fasten the sink firmly. Recheck the alignment visually from above.

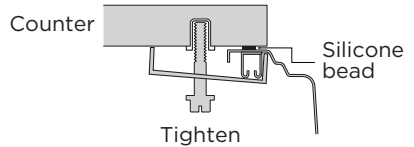

Tightening Sequence For Clips

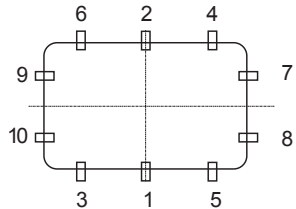

13. From the show side, carefully wipe away any excess silicone and allow the bond to rest undisturbed for 8 hours or overnight, for best results.
14. Install the countertop as directed by the manufacturer and install all other plumbing as required.

Double Sided Cutting Board

The specially designed cutting board can be used in conjunction with the sink. One side will catch drippings in the edge trough, while the other side will allow juices to drain into the sink through the handle.

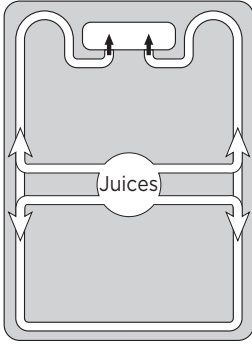

Use this side when the cutting board is in the sink track.

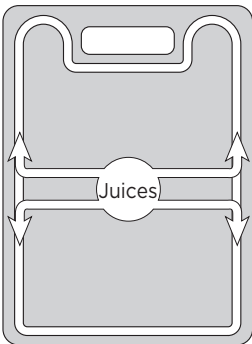

Use this side when the cutting board is on the counter top.

Care and Maintenance

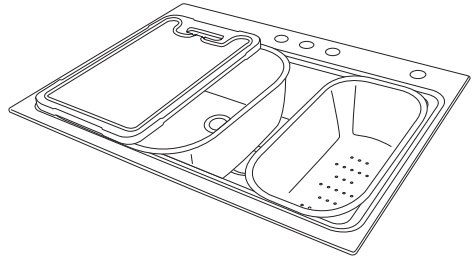

SINKS AND COLANDER

Your sinks and colander are manufactured with the highest grade stainless steel and will provide you with many years of enjoyment with the proper care and maintenance.







1. After use, always rinse your sinks and colander with tap water to dilute and remove any deposit(s). Do not allow any residue of food, detergent, soap, grease or condiment to dry or sit for extended periods of time on the surface of the sink.
2. Towel dry after use when possible to prevent water spots. Should these occur, cleanse with a mild solution of vinegar and water followed by a good rinse.
3. Use liquid soap, a general household cleaner, or a weak solution of vinegar and water for regular cleaning. Never use abrasive products as they will dull and scratch the finish.
4. Scouring pads should be of a plastic nature. They should only be used in the bowls of the sinks and colander, and the scrubbing should be done in the direction of the satin finish lines. Do not use scouring pads on the deck, as they will dull the mirror finish.
5. Never use steel wool pads, as they will leave iron particles and will lead to corrosion. For the same reason, never leave mild steel or cast iron pans on your sink for extended periods of time.

CUTTING BOARD

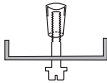
1. Do not put in the dishwasher.
2. Clean with damp cloth and dry immediately.
3. Keep away from direct sunlight or direct heat sources.

Replacement Parts

If you are missing or require replacement parts, please call customer service at 1-877-333-0098 (8:30 am - 5:00 pm EST) or email us at customer.service@conglomkb.com. Identify the required part(s) and have the replacement part number ready when you call.

Part Name	Part Number	Picture	Quantity
top mount clamps	QH0001		10
undermount clamps	QH0003		10
black leg for colander & sliding sink	QH0004		1
sliding sink	QK016		1
colander	QK017		1
bamboo cutting board	QK018		1
small strainer for sliding sink	QH0005		1

Lifetime Parts and Finish Limited Warranty

All parts and finishes of this product are warranted to the original consumer purchaser to be free from defects in material and workmanship for as long as the original consumer purchaser owns their home. We recommend using a professional plumber for all installation and repair.

We will replace, free of charge, during the warranty period, any part or finish that proves defective in material and/or workmanship under normal installation, use and service.

Replacement parts may be obtained by calling 1-877-333-0098 (8:30 am - 5:00 pm EST) or through our website at: www.conglomkb.com.

This warranty is extensive in that it covers replacement of all defective parts and even finish, but these are the only two things that are covered. LABOR CHARGES AND/OR DAMAGE INCURRED IN INSTALLATION, REPAIR, OR REPLACEMENT, AS WELL AS ANY OTHER KIND OF LOSS OR DAMAGE ARE EXCLUDED. Proof of purchase (original sales receipt) from the original consumer purchaser must be supplied for all warranty claims. THIS IS THE EXCLUSIVE WARRANTY BY CONGLOM KITCHEN & BATH, WHICH DOES NOT MAKE ANY OTHER WARRANTY OF ANY KIND, INCLUDING THE IMPLIED WARRANTY OF MERCHANTABILITY.

This warranty excludes all industrial, commercial and business usage. Some states do not allow the exclusion or limitation of incidental or consequential damages, so the above limitation or exclusion may not apply to you. Any damages to this product as a result of misuse, abuse, or neglect or any use of other than parts supplied by Conglom Kitchen & Bath WILL VOID THE WARRANTY. This warranty gives you specific legal rights, and you may also have other rights which vary from state to state.

Imported by:

Conglom
KITCHEN & BATH

St-Laurent, Quebec, H4S 2C3

1-877-333-0098 | www.conglomkb.com | Made in China

American Standard

Style That Works Better