



KING KOOKER

OUTDOOR COOKERS



2213

ASSEMBLY INSTRUCTIONS AND USE AND CARE MANUAL

MODEL/SERIAL # _____

THE INSTRUCTION MANUAL CONTAINS IMPORTANT INFORMATION NECESSARY FOR THE PROPER ASSEMBLY AND SAFE USE OF THE APPLIANCE. READ AND FOLLOW ALL WARNINGS AND INSTRUCTIONS BEFORE ASSEMBLING AND USING THE APPLIANCE. FOLLOW ALL WARNINGS AND INSTRUCTIONS WHEN USING THE APPLIANCE. KEEP THIS MANUAL FOR FUTURE REFERENCE.

METAL FUSION, INC.

712 St. George Avenue.

Jefferson, LA 70121

If you have any problems or questions

CALL US FIRST TOLL FREE AT

1-800-783-3885

7:30 AM to 3:30 P.M. CST • Monday through Friday

(504) 736-0201

www.kingkooker.com

▲WARNING

FAILURE TO FOLLOW THESE INSTRUCTIONS AND WARNINGS COULD RESULT IN FIRE, EXPLOSION, BURN HAZARD, OR CARBON MONOXIDE POISONING WHICH COULD CAUSE PROPERTY DAMAGE, PERSONAL INJURY OR DEATH.

 **DANGER**

If you smell gas:

1. Shut off gas to the appliance.
2. Extinguish any open flame.
3. Open front door slowly (if applicable). Open the door approximately 1-2 inches (2.5-5.0cm) and check for flare-up before opening door completely. Quick introduction of oxygen to the cooking chamber could lead to possible flare-up.
4. If odor continues, keep away from the appliance and immediately call your Fire Department.

FAILURE TO FOLLOW THESE INSTRUCTIONS COULD RESULT IN FIRE OR EXPLOSION WHICH COULD CAUSE PROPERTY DAMAGE, PERSONAL INJURY OR DEATH.

 **DANGER**

1. Never operate this appliance unattended.
2. Never operate this appliance within 10 feet (3.05m) of any structure, combustible material or other gas cylinder. Do not locate this appliance under ANY overhead construction.
3. Only use propane burning units outdoors. Risks include fire and carbon monoxide fumes. Lack of ventilation can cause injury or death.
4. Never operate this appliance within 25 feet (7.5m) of any flammable liquids or vapors.
5. Do not fill cooking vessel beyond maximum fill line (if applicable).
6. When cooking with oil/grease, always use the thermometer provided and never allow the oil/grease to get hotter than 350°F (177°C). If the temperature exceeds 350°F (177°C) or if oil begins to smoke, immediately turn the burner or gas supply OFF.
7. Heated liquids and equipment remain at scalding temperatures long after the cooking process. Never touch cooking appliance until liquids or cooking chamber have cooled to 100°F (38°C) or less.
8. If a fire should occur, keep away from the appliance and immediately call your Fire Department. Do not attempt to extinguish an oil/grease fire with water. When cooking, have a Type BC or ABC fire extinguisher readily available. A Type BC or ABC fire extinguisher may, in some circumstances, contain the fire.

FAILURE TO FOLLOW THESE INSTRUCTIONS AND WARNINGS COULD RESULT IN FIRE, EXPLOSION, BURN HAZARD OR CARBON MONOXIDE POISONING WHICH COULD CAUSE PROPERTY DAMAGE, PERSONAL INJURY OR DEATH.

WARNING

READ AND UNDERSTAND BEFORE USING THIS PRODUCT

Throughout this manual the words appliance, cooker, smoker, fryer/boiler, burner and stove will be used interchangeably to refer to the King Kooker® Outdoor Cooker.

- 1) **This is an ATTENDED appliance. Do NOT leave this appliance unattended while the burner is lit or while heating oil, grease, water or cooking food. Monitor the appliance when hot after use [cooking chamber, oil, grease or water above 100° F (38°C)]. Heated liquid and equipment can remain at scalding temperatures long after cooking has ended.**
- 2) **Keep children, pets and any unauthorized persons away from the appliance at all times.**
- 3) **The use of alcohol, prescription or non-prescription drugs may impair your ability to properly assemble or safely operate this appliance. Do NOT assemble or operate this appliance if using alcohol, prescription or non-prescription drugs.**
- 4) **This appliance is for OUTDOOR use only. Do NOT use in a building, garage, tent or any other enclosed area. Do NOT use in or on a recreational vehicle or boat. NEVER use this appliance as a heater.**
- 5) **Do not locate this appliance under ANY overhead construction. Keep a minimum clearance of 10 ft. (3.05m) from the sides, front and back of the appliance to ANY construction. Keep the area clear of ANY combustible material. Do not use on or under ANY apartment or condo balcony or deck.**
- 6) **When cooking, the appliance must be on a level, stable, noncombustible surface such as brick, concrete or dirt. Not suitable are surfaces such as wood, asphalt or plastic which may burn, blister or melt.**
- 7) **Check all cooker fittings for leaks before each use. Do not use a flame to check for gas leaks. Keep the fuel supply hose away from any heated surfaces. Only the LP hose/regulator assembly specified by Metal Fusion, Inc. should be used with this appliance.**
- 8) **This appliance is not for frying turkeys.**
- 9) **When cooking with oil or grease, the thermometer provided MUST be used. Follow instructions in this manual for proper installation and use of thermometer. If the thermometer supplied with the fryer/boiler has been lost or damaged, a replacement thermometer specified by Metal Fusion, Inc. shall be obtained before using the appliance.**
- 10) **If the temperature of cooking oil exceeds 350°F (177°C) or if oil begins to smoke, immediately turn the burner or gas supply OFF and wait for the temperature to decrease to less than 350°F (177°C) before relighting burner according to the instructions in this manual.**
- 11) **When cooking with oil/grease, have a Type BC or ABC fire extinguisher readily available. In the event of an oil/grease fire, do not attempt to extinguish with water. Immediately call the Fire Department. A Type BC or ABC fire extinguisher may, in some circumstances, contain the fire.**
- 12) **NEVER overfill the cooking pot with oil, grease or water. Follow instructions in this manual for establishing proper oil, grease or water levels.**

- 13) Introduction of water or ice from any source into the oil/grease may cause overflow and severe burns from hot oil and water splatter. When frying with oil/grease, all food products **MUST** be completely thawed and towel dried before being immersed in the fryer.
- 14) Never drop food or accessories into hot cooking liquid. Lower food and accessories slowly into the cooking liquid in order to prevent splashing or overflow. When removing food from the appliance, care shall be taken to avoid burns from hot cooking liquids.
- 15) This appliance and pot (including handles, doors, racks, pans and lids) get dangerously hot in use. Use well-insulated pot holders or oven mitts for protection from hot surfaces or splatter from cooking liquids. Safety goggles are also recommended to protect you from oil splatter. The oil remains dangerously hot hours after use.
- 16) Do **NOT** place an empty cooking vessel on the appliance while in operation. Use caution when placing anything in the cooking vessel while the appliance is in operation. Never use a cooking vessel larger than the capacity and diameter specified in this manual.
- 17) In the event of rain, snow, hail, sleet or other forms of precipitation while cooking with oil/grease, cover the cooking vessel immediately and turn off the appliance burners and gas supply. Do not attempt to move the appliance or cooking vessel.
- 18) Do **NOT** move the appliance when in use. Allow the cooking vessel/chamber to cool to 100°F (38°C) before moving or storing.
- 19) Avoid bumping of or impact with the appliance to prevent contact with hot appliance, spillage or splashing of hot cooking liquid.
- 20) See Use and Care section for LP Gas Cylinder Information. A 20 pound (9 kg) cylinder should be used with this cooker. The LP-gas supply cylinder used must have a protective collar and must be constructed and marked in accordance with the specifications for LP-gas cylinders of the U. S. Department of Transportation (DOT) or the National Standard of Canada, *CAN/CSA-B339, Cylinders, Spheres and Tubes for the Transportation of Dangerous Goods*. Do not store a spare LP-gas cylinder under or near this appliance. Never fill the cylinder beyond 80% full. For proper vapor withdrawal, the 20 lb. (9 kg) cylinder should be used in the proper upright position. Cylinder must be turned off while not in use. Failure to follow these instructions and warnings could result in fire or explosion which could cause property damage, personal injury or death.
- 21) This appliance is not intended for commercial use.
- 22) Use King Kooker® appliances only in accordance with state and local ordinances, or in the absence of local codes, with the National Fuel Gas Code, *ANSI Z223.1/NFPA 54, Storage and Handling of Liquefied Petroleum Gases*, *ANSI/NFPA 58* or *CSA B149.1, Natural Gas and Propane Installation Code*.

▲WARNING

FAILURE TO FOLLOW THESE INSTRUCTIONS AND WARNINGS COULD RESULT IN FIRE, EXPLOSION, BURN HAZARD OR CARBON MONOXIDE POISONING WHICH COULD CAUSE PROPERTY DAMAGE, PERSONAL INJURY OR DEATH.

**READ AND UNDERSTAND ALL INSTRUCTIONS BEFORE
USING YOUR KING KOOKER® PRODUCT**

TABLE OF CONTENTS

Warnings2-4
Table of Contents5
Warranty6
Owners Registration	7-8
Section I - King Kooker® Outdoor Cooker Assembly	9-12
Assembly Instructions9
Smoker Base/Fryer-Boiler Assembly10
Installation of Casting10
Hose Connection10
Smoker Cabinet Assembly	11-12
Section II - Use and Care of King Kooker® Outdoor Cookers and Accessories	13-20
Thermometer Instructions and Precautions for Deep Frying with Outdoor Cookers13
Determining Proper Fill Levels for Cooking Vessels13
LP Gas Cylinder Information14
Connection Instructions14
Leak Test Instructions14
Placement Instructions15
Preparation of Smoker Cabinet	15-16
Lighting and Operating Instructions17
Smoking with Propane18
King Kooker Smoking Chart18
Turning Off and Storing the Cooker After Use19
Maintenance Of Outdoor Cookers And Accessories	19-20
Caring For Aluminum and Cast Iron Cookware20
Information Regarding Cooking Oil20
Section III - Recipes	21-28
Using Wood Chips to Add Flavor21
Using Marinades/Dry Seasonings to Add Flavor21
Recipes for Smoked Foods	21-25
Other King Kooker Specialities	26-28
Section IV - Frequently Asked Questions29

METAL FUSION, INC.

LIMITED ONE-YEAR WARRANTY

WHAT THIS WARRANTY COVERS

This warranty covers all components of this outdoor cooker to be free from defects in materials and workmanship, with the exceptions stated below.

HOW LONG COVERAGE LASTS

This warranty runs for one year from the date of purchase. Please keep your receipt with this manual for future reference.

WHAT IS NOT COVERED

This warranty does not cover the following:

Incidental and Consequential Damages. This warranty does **not** cover incidental and consequential damages arising in any way out of the use of this outdoor cooker. The liability of Metal Fusion, Inc. is, in any event, limited to the amount of the original purchase price of this outdoor cooker, and remains in force only as long as the product remains in its original, as-built configuration. Some states do not allow the exclusion or limitation of incidental or consequential damages, so the above limitation or exclusion may not apply to you.

Neglectful Operation. This warranty does **not** cover any loss or damage arising in any way due to the negligent operation of this outdoor cooker.

Altered, Repaired or Misused Equipment. This warranty does **not** cover any loss or damage arising in any way out of the use of this outdoor cooker when it has been altered, repaired by persons other than Metal Fusion, Inc., or when it has been abused or misused, or when it has been used other than in accordance with the manufacturer's operating instructions, including, without limitation, any damage to the consumer's pots because they were placed on a lit cooker while the pot is empty. When using smoker, use only the porcelain water pan provided.

Other Assumed Responsibilities. Unless otherwise provided by law, this warranty does **not** cover any responsibility or liability arising in any way out of the use of this product where that responsibility or liability was purportedly assumed by any other person or agent.

Paint, Discoloration and Rust. This warranty does **not** cover the paint on the outdoor cooker, as in a normal use of the outdoor cooker, the paint will be burned off. Nor does this warranty cover discoloration or rust as these occurrences are part of the cooker's normal wear and tear.

WHAT METAL FUSION, INC. WILL DO

Metal Fusion, Inc. will repair or replace any outdoor cooker that proves to be defective in materials or workmanship. In the event repair is not possible or economically feasible, Metal Fusion, Inc. will replace your outdoor cooker with an identical or substantially equivalent outdoor cooker. Metal Fusion, Inc. will perform this service at no charge to you, except for the actual cost of shipping and handling the outdoor cooker or replacement parts.

HOW TO GET SERVICE

In the event you have a problem or malfunction with your outdoor cooker, simply call Metal Fusion, Inc. at (800) 783-3885.

HOW STATE LAW APPLIES

This warranty gives you specific rights, and you may have other rights which vary from state to state.

OWNER'S REGISTRATION



Dear Customer,

Thank you for purchasing a King Kooker®! Please take a moment to fill out your registration form and return it to us. We are always happy to hear suggestions and comments from our customers about our products. Completion of this registration allows us to contact you if the need arises. Please keep your receipt with your instruction manual. It will be necessary as a proof of purchase for us to help you if there is a problem with your cooker.

Name: _____

Email: _____

Address: _____

Phone: _____

Model# _____

Date of Purchase _____

Place of Purchase _____

Price Paid _____

Was this a gift _____ or did you _____ purchase it yourself?

Comments:

A SATISFIED CUSTOMER IS OUR MAIN GOAL. If you have any questions or problems, please call us at 1-800-783-3885 before returning the product to the point of purchase. Please have your receipt available when calling.

CUT HERE

**THANK YOU,
ENJOY YOUR COOKING EXPERIENCE.**

TAPE HERE

FOLD

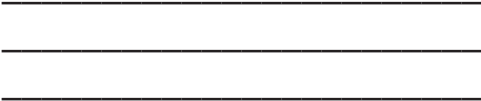

Place
Stamp
Here

METAL FUSION, INC.
712 St. George Avenue
Jefferson, LA 70121

FOLD

SECTION I

OUTDOOR COOKER ASSEMBLY

⚠ WARNING

THE USE AND CARE MANUAL MUST BE READ AND UNDERSTOOD BEFORE USING THE APPLIANCE

Throughout this manual the words appliance, cooker, smoker, fryer/boiler, burner and stove will be used interchangeably to refer to the King Kooker® Outdoor Cooker.

ASSEMBLY INSTRUCTIONS

Tools Required:

Phillips Head Screwdriver, Adjustable Wrench, Leak Testing Solution

1. Before assembling, check that all cooker components are included in the shipping carton. Identify these cooker parts from the parts list for both the Smoker Base/Fryer-Boiler Assembly and the Smoker Cabinet Assembly. If any parts are missing, contact Metal Fusion, Inc. at (800)783-3885 between the hours of 7:30 a.m. and 3:30 p.m. CST Monday through Friday for replacements.
2. Read assembly instructions, and understand sequence of assembly, before commencing to assemble your cooker.
3. This package consists of two main components once assembled:
 1. **Smoker Base/Fryer-Boiler** - See page 10 for assembly.
 2. **Smoker Cabinet** - See pages 11-12 for assembly.

The smoker base/fryer-boiler provides a stable base and heat source for the smoker cabinet. The smoker base/fryer-boiler can also be used independently from the smoker cabinet as an outdoor cooker. When using this appliance as a fryer-boiler alone (no smoker), do NOT use any pot larger than 32 quarts.

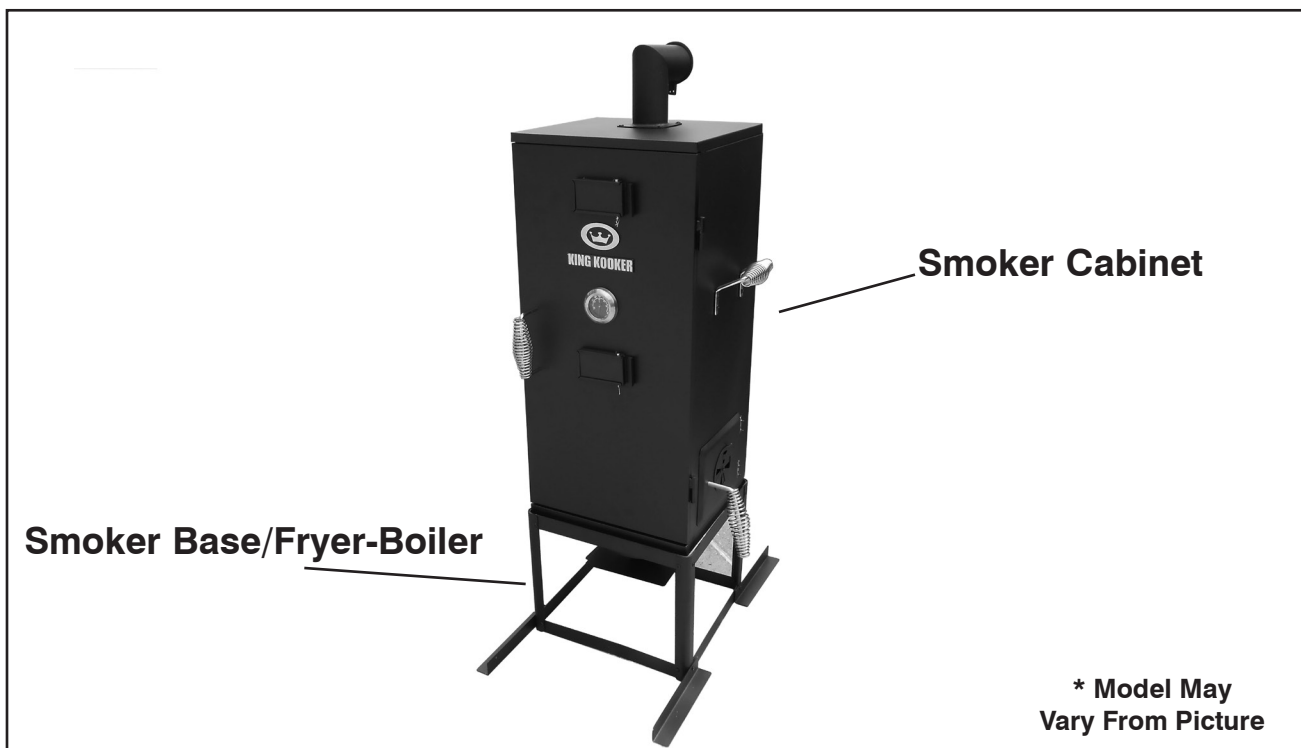

SMOKER BASE/FRYER-BOILER ASSEMBLY

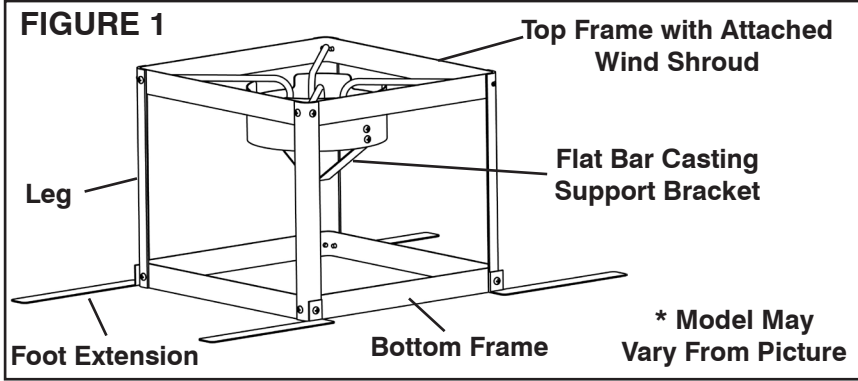

- PARTS LIST:**
- (1) Top Frame with Attached Wind Shroud
 - (1) Flat Bar Casting Support Bracket
 - (1) Bottom Frame
 - (4) Legs
 - (4) Foot Extensions
 - (16) Nuts
 - (16) Philips Head Bolts
 - (1) Heat Plate
 - (1) Casting/Air Shutter
 - (1) Hose and Regulator
 - (1) 12" Deep Fry Thermometer

1) Legs bolt to the outside of both the top and bottom frames (16 bolts and nuts.) Attach foot extensions to legs as pictured in Figure 1 using 4 leg to frame bolt connections. Hand tighten only until all legs and foot extensions are installed.

2) Wrench tighten. Make sure all bolt sets are used (16) and unit stands sturdily.

Installation of Casting

- 1) Remove top nut from casting bolt. Leave bottom nut attached and tightened (if applicable.)
- 2) Place the casting bolt through the hole on the flat bar casting support bracket as pictured below. The venturi tube of the burner should be located underneath the windshroud. Place the heat plate onto the casting bolt beneath the flatbar casting support bracket.
- 3) Reinstall nut to casting bolt. Tighten. Check to see if casting is pointing straight up and is sturdy.

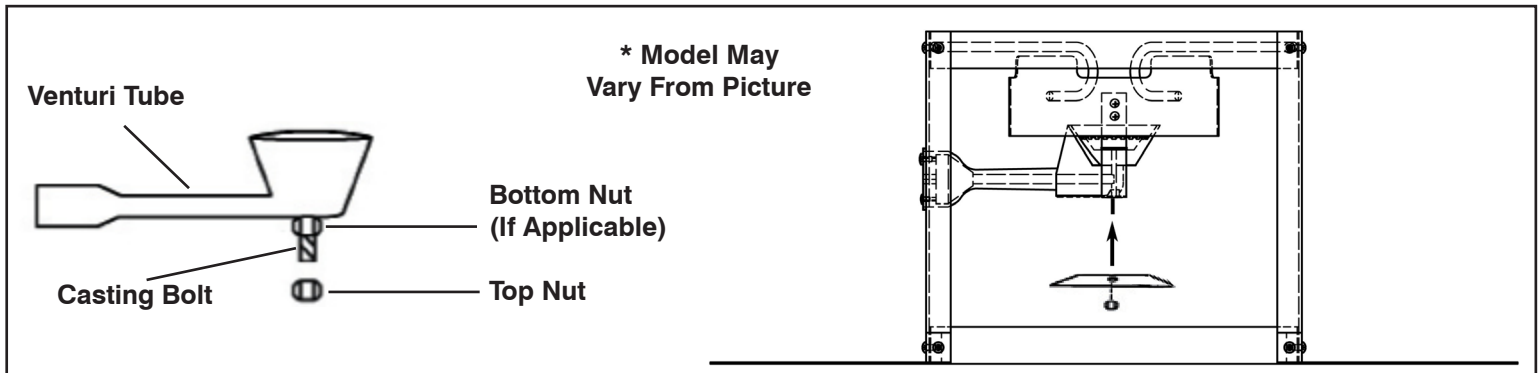

Hose Connection to Smoker Base/Fryer-Boiler

- (1) Refer to below diagram for depiction of proper hose installation.
- (2) Tighten the hose fitting into the Venturi with a torque wrench, up to a torque of 95 to 105 lb./in. Alternatively, hand tighten securely and then, using a wrench, tighten an additional 1-1 1/2 turns.
- (3) If using this cooker as a fryer-boiler, go to the **Use and Care** section of this manual for further instructions. If using as a smoker base, continue on to the next page.

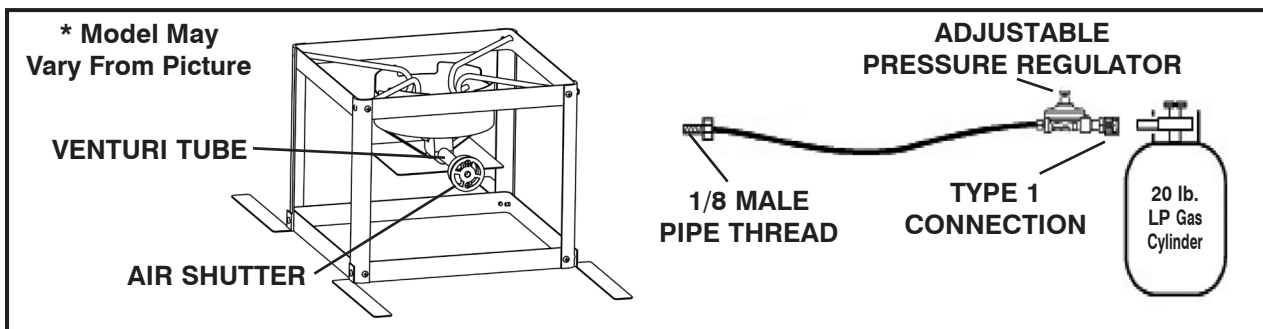

SMOKER CABINET ASSEMBLY

Parts List:

- (1) Smoker Cabinet
- (1) Front Door
- (1) Cool Grip Front Door Handle
- (1) Cool Grip Side Door Handle
- (1) Side Door Latch, Lockwasher and Nut
- (2) Cool Grip Side Handles with 8 bolts
- (1) Chrome Rack
- (1) Wood Chip Pan and Lid
- (1) Water Pan
- (2) Side Dampers
- (1) Adjustable Stack with Damper and red "Hot" Signal Plate.
- (1) Cabinet Thermometer
- (6) Bolts (Black)
- (3) Sliding Racks

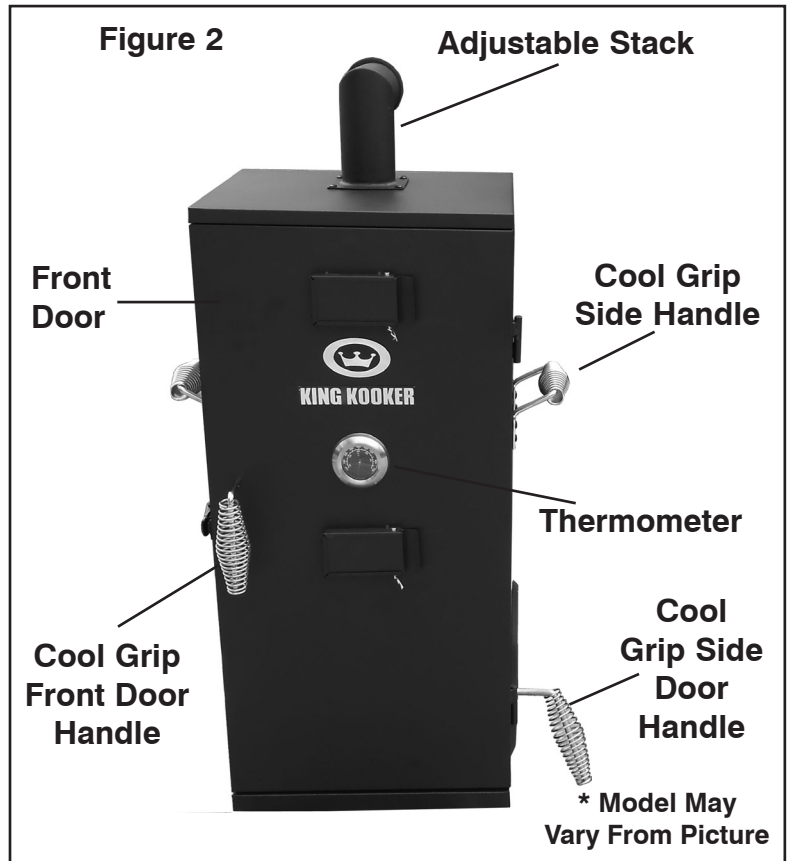

1. Turn the smoker cabinet upside down. Locate the chrome rack. Remove the four nuts pre-attached to the threaded ends of the rack. Install the chrome rack to the bottom of the smoker cabinet by inserting the threaded ends of the chrome rack through the four holes provided on the bottom of the smoker cabinet. Re-attach the four nuts to the threaded ends of the rack on the bottom of the smoker cabinet. Tighten. See Figure 3.

Figure 3

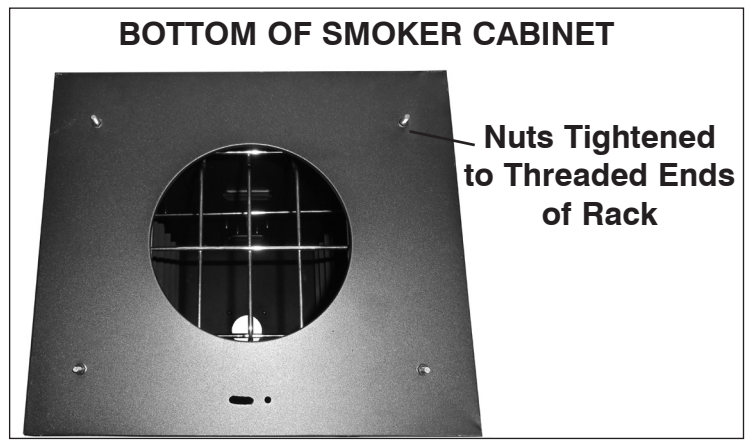
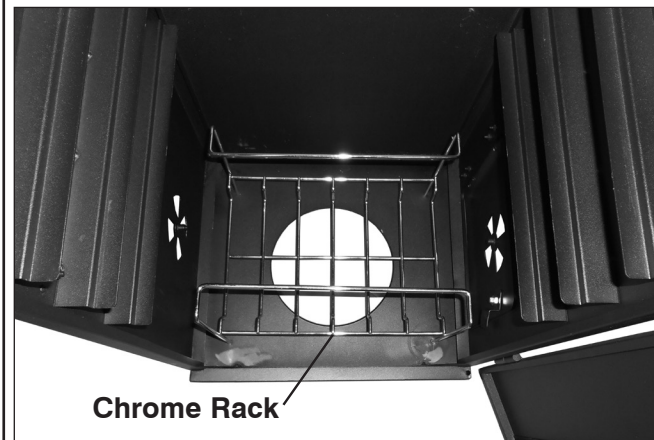

2. Turn smoker right side up. Install adjustable stack on top of smoker using four black bolts. Bolts should thread towards inside of smoker. The adjustable stack vent should be directed towards the back of the smoker (see Figure 2).
3. Install cool grip side handles on both sides of smoker using eight black bolts (four on each handle). Bolts should thread towards inside of smoker (see Figure 2).

4. Install the two side dampers onto the smoker cabinet using two black bolts (one bolt on each damper). Bolts should thread toward inside of smoker (see Figure 4).

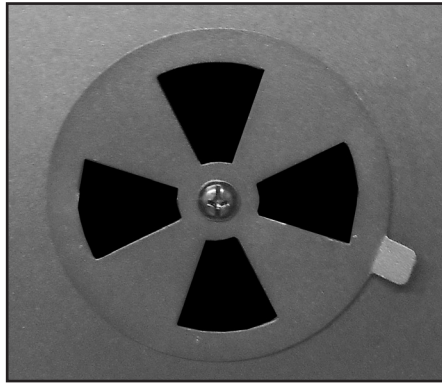

Figure 4

5. Locate the cool grip door handle. Remove the two bolts that are pre-attached to the extensions of the handle. Align the two extensions of the cool grip door handle to the two holes provided on the outside of the smoker door. Re-attach the two bolts to the extensions of the cool grip door handle from the inside of the smoker door. Tighten. See Figure 2, page 11.
6. Install side smoker access door handle using one cool grip handle, latch, lockwasher and nut. Insert handle through side smoker door as shown in Figure 5. Keep cool grip handle horizontal. Place latch over threaded end of handle on back side of side smoker door. The bend on latch should be pointed down (See Figure 5 below). Tighten with supplied lockwasher and nut. Turn side access door handle down to latch in place.

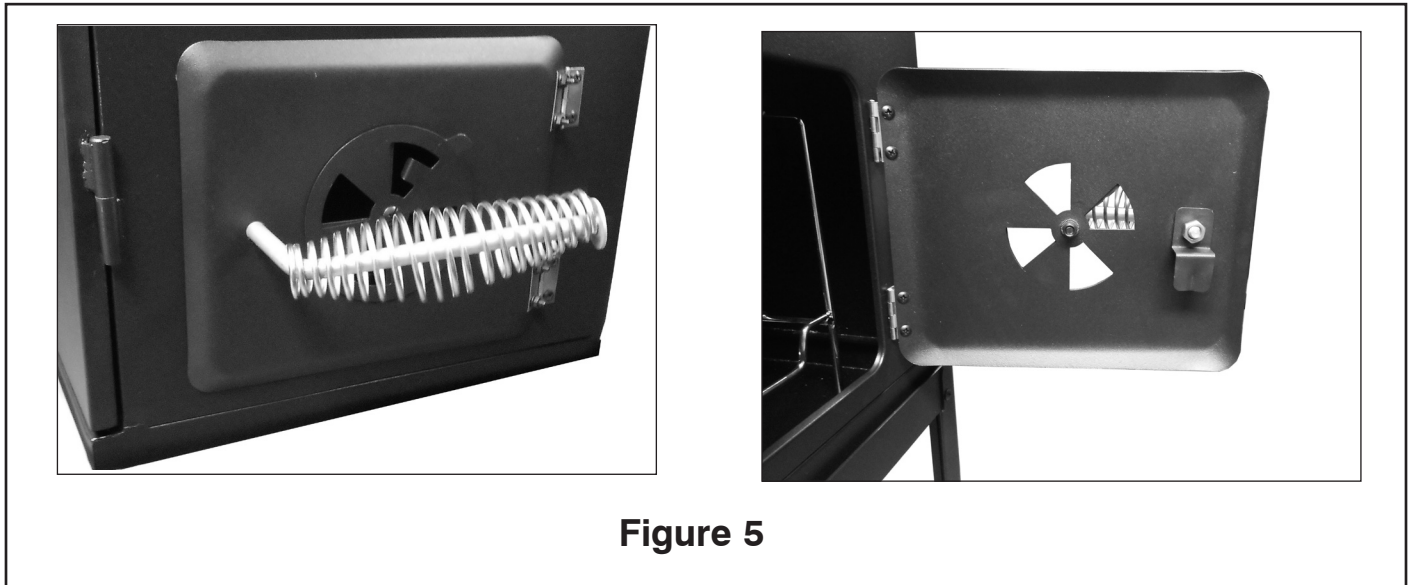

Figure 5

7. Install the smoker front door to the “right” side wall using the provided bracket pins/receivers located on outside of wall. See Figure 2, page 11.
8. Install cabinet thermometer on front smoker door. Remove nut from stem of thermometer and insert stem through the front of the smoker door in hole provided. Reattach nut to thermometer stem on inside of door to tighten. See Figure 2, page 11 for proper thermometer placement.
9. Go to the **Use and Care** section of this manual for further instructions.

SECTION II

USE AND CARE

Throughout this manual the words appliance, cooker, fryer/boiler, and smoker will be used interchangeably to refer to the King Kooker® Outdoor Cooker.

READ AND UNDERSTAND BEFORE USING THIS APPLIANCE

FAILURE TO FOLLOW THESE INSTRUCTIONS AND WARNINGS COULD RESULT IN FIRE, EXPLOSION, BURN HAZARD OR CARBON MONOXIDE POISONING WHICH COULD CAUSE PROPERTY DAMAGE, PERSONAL INJURY OR DEATH.

THERMOMETER INSTRUCTIONS AND SAFETY PRECAUTIONS FOR DEEP FRYING WITH OUTDOOR COOKERS

1. Always use a deep fry thermometer when using this appliance as a fryer/boiler.
 - a. Before each use of the appliance make sure that the thermometer is properly calibrated by placing the tip in a pot of boiling water. The thermometer should register within $\pm 20^{\circ}$ of 212°F or $\pm 10^{\circ}$ of 100°C . If the thermometer is miscalibrated, contact Metal Fusion, Inc. to obtain a replacement before using the appliance.
 - b. Hang the thermometer on the inside of the pot with the probe immersed in the cooking liquid. Never place a lid over a pot when monitoring the temperature of oil.
 - c. Once the fire has been lit monitor the temperature on the thermometer at all times. Water boils at 212°F (100°C). The temperature of hot oil should never be allowed to exceed 350°F (177°C).

IMPORTANT: Oil can ignite at high temperatures. Most King Kooker® thermometers have a Red Zone above 350°F (177°C) to signify Danger. Never allow the temperature to exceed 350°F (177°C). If the temperature goes above 350°F (177°C) immediately turn the burner and gas supply OFF and wait for the temperature to decrease to below 350°F (177°C) before relighting according to instructions in the manual. If at any point during the cooking process the oil begins to smoke, immediately turn the burner and gas supply OFF regardless of the reading on the thermometer. Allow time for the oil to cool, then contact Metal Fusion, Inc. for further instructions.
 - d. When the cooking is complete and the cooker has been turned off, allow the temperature of the cooking liquid to fall below 100°F (38°C) before moving the pot, cooking oil, or cooker.
 - e. Please call Metal Fusion, Inc. at (800) 783-3885 with any questions concerning the use or operation of the thermometer.
2. Never cover the pot when cooking with oil.
3. Always thaw and dry food completely before placing it into hot oil. Frozen or wet food may cause oil or grease to overflow.
4. Never put an empty pot over an open flame.
5. In the event of rain, snow, hail, sleet or other forms of precipitation while cooking with oil/grease, cover the cooking vessel immediately and turn off the appliance burners and gas supply. Do not attempt to move the appliance or cooking vessel.
6. When cooking with oil or grease, fire extinguishing materials shall be readily accessible. In the event of an oil or grease fire do NOT attempt to extinguish with water. Immediately call your Fire Department. A Type BC or Type ABC fire extinguisher may, in some circumstances, contain the fire.
7. This appliance is not for frying turkeys.

DETERMINING PROPER FILL LEVELS FOR COOKING VESSELS

Never overfill the cooking vessel with oil, grease or water. Never fill a pot beyond the maximum fill line. If the pot being used does not have a maximum fill line, follow these instructions to determine the amount of cooking liquid to be used:

- a. Place the food product in or on the holder.
- b. Place the food product and holder into the empty vessel.
- c. Fill the vessel with water until the food product is completely submerged. There must be a minimum of 3 inches (7.6cm) between the water level and top of the vessel.
- d. Remove the food product from the vessel and either mark the water level on the side of the vessel or measure the amount of water in the vessel.
- e. Remove the water and completely dry the vessel and the food product.
- f. This is the amount of cooking liquid the vessel is to be filled with to cook the food product.

LP GAS CYLINDER INFORMATION

King Kooker® Outdoor Cookers are manufactured for use with **20lb. (9 kg) LP Gas Cylinders**. Important information to remember about LP Gas cylinders include:

1. Always read and follow the cylinder manufacturer's instructions.
2. Make sure that the gas cylinder is not overfilled. The maximum weight of a properly filled 20 lb. (9 kg) LP gas cylinder is approximately 38 lbs (17 kg). Never fill the cylinder beyond 80% full.
3. Make sure that the cylinder valve has the proper connection for a Type 1 appliance fitting.
4. Do not store a spare LP gas cylinder under or near this appliance.
5. Disconnect the cylinder from the cooker for storage.
6. Store the cylinder out of the reach of children.
7. Do not use or store the cylinder in a building, garage or enclosed area.
8. Always use a 20 lb. (9 kg) cylinder in the proper upright position for the proper vapor withdrawal. It should also be stored and transported in the upright position.
9. The cylinder must have a protective collar to protect the cylinder valve.
10. Place dust cap on cylinder valve outlet whenever the cylinder is not in use. Only install the type of dust cap on the cylinder valve outlet that is provided with the cylinder valve. Other types of caps or plugs may result in leakage of propane.
11. Cylinder must be turned OFF while not in use.

⚠WARNING

ALWAYS READ AND FOLLOW THESE AND THE CYLINDER MANUFACTURER'S INSTRUCTIONS. FAILURE TO FOLLOW THESE INSTRUCTIONS AND WARNINGS COULD RESULT IN FIRE, EXPLOSION, BURN HAZARD OR CARBON MONOXIDE POISONING WHICH COULD CAUSE PROPERTY DAMAGE, PERSONAL INJURY OR DEATH.

CONNECTION INSTRUCTIONS

1. Check that your hose assembly valve is set to not allow gas flow. Turn the regulator control counterclockwise until it stops. This is the OFF position.
2. Attach the regulator to the cylinder valve by turning the Type 1 fitting clockwise. Hand tighten with the regulator positioned upright. Refer to the assembly diagram for the appliance below.

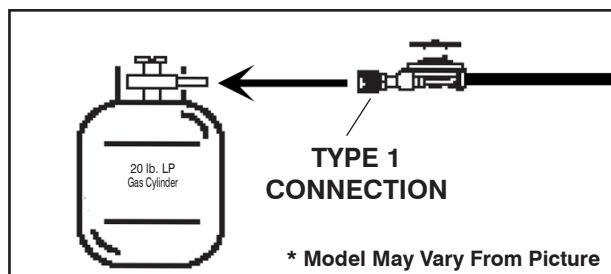

3. Perform the Leak Test:

LEAK TEST

Before lighting the appliance, a thorough leak test must be satisfactorily completed using a non-ammonia soapy water solution (50% non-ammonia soap and 50% water). This is to be applied with a small brush to all gas joints after the cylinder valve is opened (no more than 1/2 turn). If bubbles are seen, indicating a leak, turn off the cylinder and tighten the leaking connection until a further leak test shows no leaks.

If tightening the connection does not stop the leak, call Metal Fusion, Inc. (800) 783-3885, for assistance.

NEVER USE HOSE/REGULATOR ASSEMBLY IF LEAKING.

4. Before lighting the cooker, check that the venturi tube is free of obstruction and that the orifice is properly threaded into the venturi tube as per the "Hose Connection" instructions on page 10. Both situations must be corrected if necessary before lighting to prevent flashback.

PLACEMENT INSTRUCTIONS

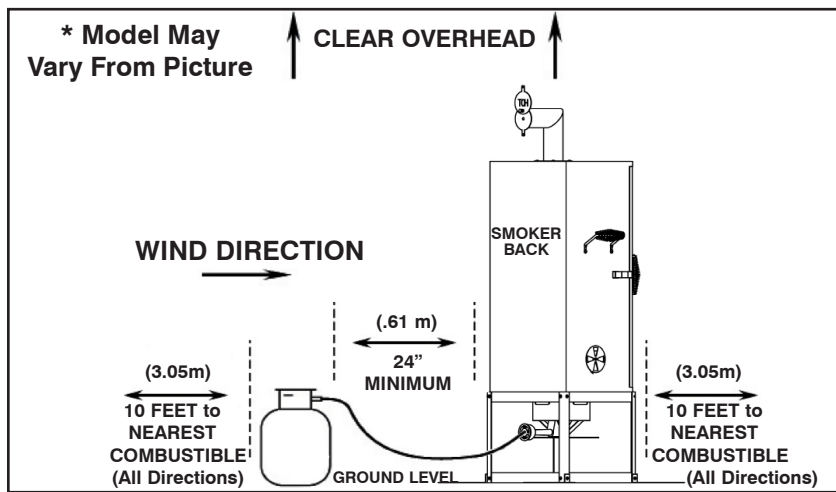

WARNING

Keep twenty-four inches (.61m) between the cylinder and the appliance. Placing the cylinder too close to the appliance could result in fire or explosion which could cause property damage, personal injury or death.

The hose connecting the appliance to the tank poses a trip hazard. Do not step over the hose or walk between the cylinder and appliance. Tripping could cause the appliance or cylinder to tip over, leading to fire or explosion which could cause property damage, personal injury or death.

1. Never operate this appliance within 10 feet (3.05m) of any structure, combustible material or other gas cylinder. Never operate this appliance within 25 feet (7.5m) of any flammable liquids or vapors.
2. There must be no combustibles or roof overhead.
3. Keep 24 inches (.61m) of space between the LP gas cylinder and the appliance.
4. The LP gas cylinder and appliance must be located so that any wind is blowing the heat of the appliance away from the propane cylinder. This also helps fire prevention by blowing the flames of a grease fire away from the propane cylinder.
5. Center the smoker/pot over the burner on the cooker. Do NOT use any pot larger than 32 quarts.

PREPARATION OF SMOKER CABINET

1. Place the smoker cabinet on the smoker base/fryer-boiler. The smoker door should be placed facing the opposite direction of the hose. The bottom of the smoker cabinet should be placed within the raised ring of the smoker base/fryer-boiler. This provides a stable support for the unit.
2. Next, prepare the wood chip and water pans for smoking (See below picture for proper pan placement). The water pan should always be installed into the smoker when cooking (the water pan will collect drippings from hot food and extend your burner's life). Only use water pan provided with this unit.

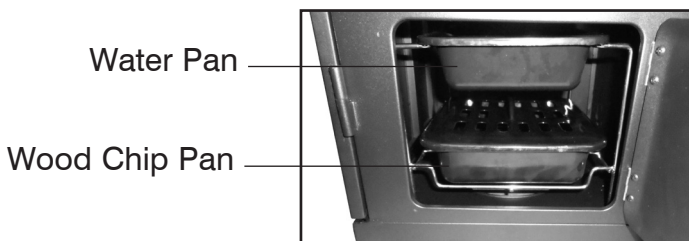

Top lip of water pan slides in and rests on rack guides.

Wood chip pan rests on bottom rack shelf.

**INSERT
AND REMOVE
PANS
THROUGH
SIDE ACCESS
DOOR**

Wood Chip Pan for Wet or Dry Smoking: If a wood smoked flavor is desired, use the wood chip pan, placed on the bottom rack shelf. Do not place the wood chip pan in the smoker cabinet at the beginning of the smoking process. When only one hour of smoking time is left remove the lid from the wood chip pan and add the desired amount of wood chips. Place lid back on the wood chip pan. Open the side door of the smoker. Wearing protective mitts, carefully place the wood chip pan onto the bottom rack shelf. The smoker will be extremely hot. Close the door and allow the remaining cooking time to pass. Refer to "Using Wood Chips to Add Flavor" on page 21 for more information.

Water Pan for Wet Smoking: Fill the water pan to within 1/2 inch (1.27 cm) of the top with water and your favorite marinade, soft drink or beer. Place the water pan inside the smoker using the guides right above the wood chip pan, before lighting your cooker. Check the water pan every hour during cooking using protective oven mitts. The smoker and water pan will be extremely hot. Use caution when removing and installing the water pan as hot liquid can splash. Never allow the water to completely evaporate.

For Dry Smoking: Do not add water or marinade to the water pan.

Tip: Line the water pan with aluminum foil for easy clean up.

3. Preparing the Racks:

Open door to main smoking chamber. Arrange food in smoking chamber as desired using supplied racks. This smoker is equipped with several racks to allow for smoking a wide variety of foods at once. The pre-installed mounting guides allow for varying rack placement inside the smoker cabinet. Arrange racks and food before lighting. Use well insulated pot holders or oven mitts for protection from hot surfaces when handling. Use caution and exercise care when operating the racks. Wearing protective mitts, support the rack completely with your hands when you slide it forward to check the food or to remove the rack. Do not extend the rack more than halfway out of the smoker unless supporting it with both hands to prevent spilling the food as the rack is removed from the smoker. Do not release the rack unless it is fully inserted into the smoker or completely removed from the smoker and placed on a stable safe surface to check food.

Sliding Racks (3): The racks are equipped with guide tabs (four on each rack.) The guide tabs are designed to help keep the racks centered while installing or removing from the cabinet. Slide rack completely to rear of the smoker cabinet. To remove the rack, slightly raise front of rack and carefully pull to front.

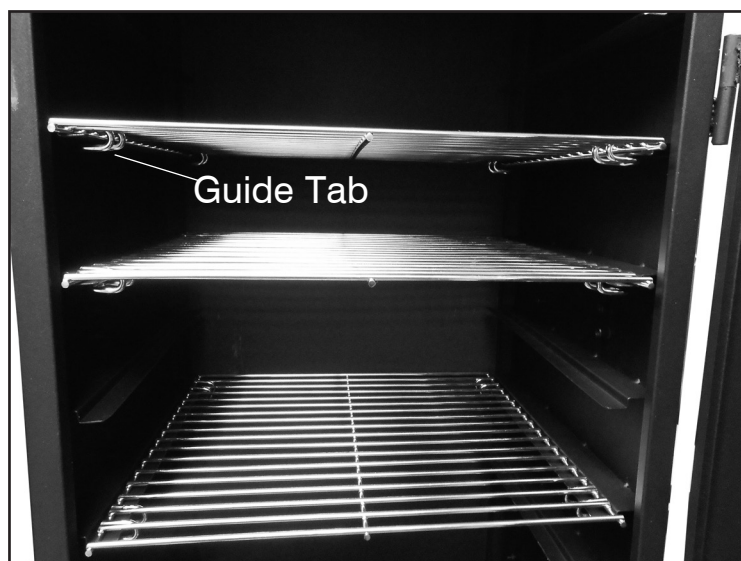

4. Light the smoker according to the “Lighting Instructions” on page 17.

LIGHTING AND OPERATING INSTRUCTIONS

⚠WARNING

THE SMOKER/COOKER MUST NOT BE LIT UNTIL THE PRECEDING PLACEMENT INSTRUCTIONS HAVE BEEN COMPLETELY FOLLOWED.

1. Check the casting (burner) to make sure it is set up as per the illustration (**Figure 1**). When using this appliance as a smoker, never light the burner with the smoker door closed. Never lean into the smoker chamber while lighting. Locate the plate embossed with HOT on the stack on top of the cabinet. Turn the plate until it is fully exposed. This signals that the smoker is HOT while in use.
2. Make certain that the regulator control is turned to OFF by turning it counterclockwise until it reaches the stop (**Figure 2**).
3. Open cylinder control valve by turning it counterclockwise as per the diagram (**Figure 2**).
4. Insert a multipurpose lighter through the hole in the shroud as per **Figure 4**, or use a paperbook match placed above the casting as per **Figure 3**. Turn the regulator control toward the "ON" position until ignition occurs. Turning the regulator control clockwise increases the gas pressure to the burner and hence the flame size (**Figure 2**). When lighting the stove, if ignition does not occur in 3 to 5 seconds, turn the regulator and cylinder valve off. Wait 5 minutes for gas to disperse. Repeat procedure.
5. Check that the flame is blue and that the flames are emitted from every port in the casting. If not, rotate the air shutter position until there is a blue flame. Opening the shutter too much will cause the flame to "Lift" off the burner (**Figure 5**). If there is a yellow flame, or if some ports have no flame, this indicates there may be an obstruction in the venturi tube or ports. Check the maintenance instructions on pages 19-20 for more information regarding a yellow flame.
6. Always monitor the flame throughout the cooking process. If at any point in the cooking process the flame is accidentally extinguished, immediately turn the regulator and cylinder valve OFF. Open main smoker door slowly (if applicable), wait 5 minutes for gas to disperse and relight the cooker according to the lighting instructions (#1-#5) in this section.

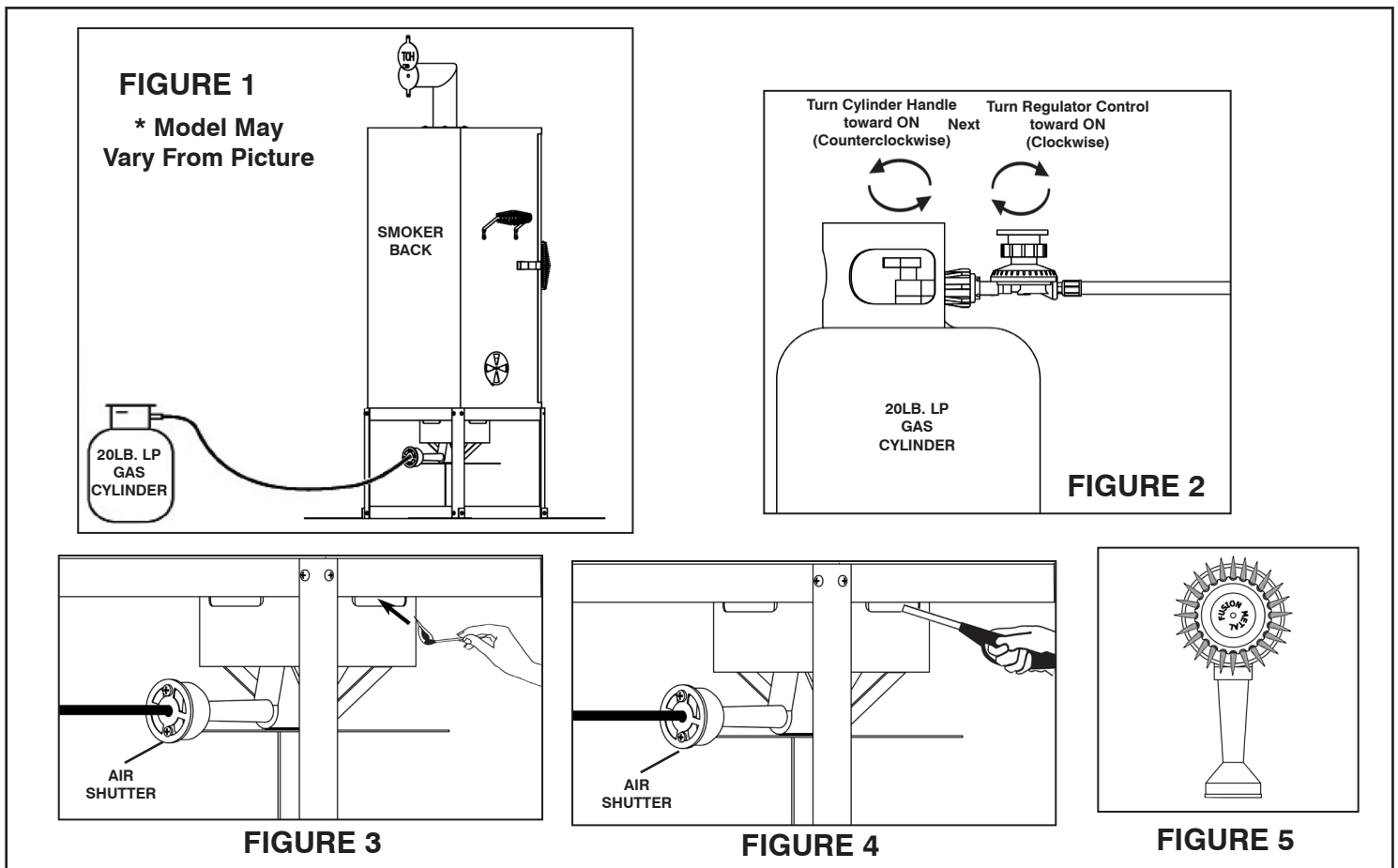

⚠WARNING

NEVER PUT HANDS OR FACE DIRECTLY OVER BURNER WHILE LIGHTING OR WHILE THE APPLIANCE IS LIT.

SMOKING WITH PROPANE

- Once the cooker is lit according to the **Lighting and Operating Instructions** on page 17, set the flame intensity to the desired setting. When smoking with propane, the heat intensity will remain constant.
- Use the thermometer to monitor the temperature of the smoker. If it falls lower than the desired temperature, turn up the flame intensity by adjusting the regulator. Adjust the damper(s) more open to reduce heat or closed to increase heat.
- When checking food for doneness, open the door approximately 1-2 inches (2.5-5.0cm) and check for flare-up before opening door completely. Quick introduction of oxygen to the cooking chamber could lead to possible flare-up. Opening the door adds cooking time to the food. When the outside temperature drops below 60° F (16° C), we suggest adding more cooking time.
- Use caution and exercise care when operating the racks. Wearing protective mitts, support the rack completely with your hands when you slide it forward to check the food or to remove the rack. Do not extend the rack more than halfway out of the smoker unless supporting it with both hands to prevent spilling the food as the rack is removed from the smoker. Do not release the rack unless it is fully inserted into the smoker or completely removed from the smoker and placed on a stable safe surface to check food.
- See below chart for estimated cooking times. Variations will result depending upon the distance of the food to the flame, amount of food in the smoker and the number of times the door is opened during cooking.

KING KOOKER SMOKING CHART

FOOD	QUANTITY	APPROX. COOKING TIME 300-350°F(149-177°C)-MEDIUM HEAT	FULLY COOKED MEAT/TEMP/DESC. (Use a meat thermometer)	
Fish & Seafood				
Whole, Large	4 to 6 lbs.	2 to 3 hrs.	Flakes Easily With Fork	
Whole, Small	FULL RACK	1 to 2 hrs.	Flakes Easily With Fork	
Fillet	FULL RACK	3/4 to 1 hr.	Flakes Easily With Fork	
Shrimp, Crablegs	FULL RACK	1/2 to 1 1/2 hrs.	Pink, Resilient	
Lobsters			Meat Pulls Away from Shell	
Poultry				
Chicken, Whole or Split	1 to 4 Fryers	2 1/2 to 3 hrs.	{ Slice Leg Joint to Check for Doneness 190°F(87° C) 190°F(87° C) 190°F(87° C) 190°F(87° C) 190°F(87° C) 190°F(87° C) 190°F(87° C) Well Done	
Chicken, Stuffed	1 to 4 Fryers	3 1/2 to 4 1/2 hrs.		
Chicken, Breast Parts	FULL RACK	2 1/2 to 3 hrs.		
Turkey	12 to 20 lbs.	4 to 5 hrs.		
Turkey Stuffed	12 to 20 lbs.	4 to 5 hrs.		
Small Game Bird	FULL RACK	1 1/2 to 2 1/2 hrs.		
Large Game Bird	5 to 7 lbs.	3 to 4 hrs.		
(Duck, Pheasant, Goose)				
Beef				{ 140°F(60° C) Rare 160°F(71° C) Medium 170°F(77° C) Well Done
Whole Rump Roast	4 to 6 lbs.	3 to 5 hrs.		
Brisket	1 to 6 lbs.	5 to 7 hrs.		
Ribs	FULL RACK	3 to 3 1/2 hrs.		
Pork				
Ribs	FULL RACK	3 to 3 1/2 hrs.	170°F(77° C)	
Chops (3/4")	FULL RACK	2 1/2 to 3 1/2 hrs.	170°F(77° C)	
Ham (Pre-Cooked)	All Sizes	2 to 3 hrs.	130°F(54° C) Well Done Meat Pulls Away From The Bone	
Lamb				
Leg	3 to 6 lbs.	3 to 5 hrs.	180°F(82° C)	
Wild Game				
Venison	1 to 5 lbs.	2 to 5 hrs.	170°F (77° C)	

ALL COOKING TIMES ARE ESTIMATES

A meat thermometer can determine the proper amount of doneness.

Place the thermometer into the thickest part of the meat for 5 minutes to register the temperature immediately after removing from smoker. Make sure it is not touching the bone.

TURNING OFF AND STORING THE COOKER AFTER USE

⚠WARNING

NEVER MOVE THE SMOKER, COOKER OR POT WHILE IN USE OR STILL HOT {ABOVE 100°F(38°C)}.

1. After each use turn OFF the King Kooker® at the regulator first, then at the gas cylinder valve. **Check to make sure there is no flame and all valves are OFF.** Do not leave the smoker/cooker until it has cooled completely. When removing food from the smoker/cooker wear protective mitts.
2. Disconnect the regulator from the cylinder by turning the Type 1 fitting counterclockwise until the regulator is separated from the tank.
3. Storage of this smoker/cooker indoors is permissible only if the cylinder is disconnected and removed from the cooker. Do not use or store cylinder in a building, garage or enclosed area. Read and follow cylinder manufacturer's instructions. The cylinder must be stored out of the reach of children at all times. Keep entire unit in area to avoid insects and contamination that can clog the venturi tube.

⚠WARNING

FAILURE TO FOLLOW THESE INSTRUCTIONS AND WARNINGS COULD RESULT IN FIRE, EXPLOSION, BURN HAZARD OR CARBON MONOXIDE POISONING WHICH COULD CAUSE PROPERTY DAMAGE, PERSONAL INJURY OR DEATH.

MAINTENANCE OF OUTDOOR COOKERS AND ACCESSORIES

1. The area where the cooker will be used must be kept clear and free from combustible materials, gasoline and other flammable vapors and liquids. Before each use of the appliance, inspect and remove any combustible items.
2. The flow of combustion and ventilation of air must not be obstructed. The cooker must be set in an open area with 10 ft. (3.05m) of space on all sides and no roof or overhang overhead. Check the location and placement of the cooker before each use.
3. Before each use of the appliance check the burner/venturi tube for insects, insect nests, and other obstructions. A clogged tube can lead to a fire beneath the appliance.
4. Follow all Lighting Instructions in the Use and Care Manual each time the cooker is used. Check the flame for proper color and appearance. The flame should burn with a primarily blue color. If a strong yellow flame is present, this could indicate an obstruction in the burner/venturi tube.
If there is any obstruction or a yellow flame, and the air shutter adjustment has not solved the problem, turn off the cooker and allow time for it to cool. Disconnect the hose from the cooker. Remove the air shutter using a phillips head screwdriver. Check the venturi tube with a flashlight to see if there is a blockage. If a blockage is present use a wire such as a coat hanger to slide into the venturi tube to remove the blockage. Reattach the air shutter to the venturi tube using the phillips screwdriver. Assemble and light the cooker again as per the instruction manual. If this does not resolve the problem, please call Metal Fusion, Inc. at (800) 783-3885 between the hours of 7:30am-3:30pm (CST) Monday through Friday.
5. Always use the LP Hose/Regulator assembly supplied with the appliance. Before each use of the appliance check the LP Hose for evidence of abrasion, wear, cuts or leaks. If there is any damage to the hose, the hose/regulator assembly must be replaced prior to using the appliance. Contact Metal Fusion, Inc. at (800) 783-3885 for information regarding a replacement hose assembly. Only the LP Hose/Regulator assembly specified by Metal Fusion, Inc. should be used with the appliance.
6. For purchase of any replacement parts which may have become damaged or lost, please contact Metal Fusion, Inc. at (800) 783-3885 between the hours of 7:30am-3:30pm (CST) Monday through Friday.

7. Cleaning of the appliance:

Smoker Base/ Fryer-Boiler and Hose/Regulator: If necessary, remove any oil or liquid which has spilled onto the unit during cooking with mild soapy water on a rag and towel dry. Do not immerse the burner unit or hose/regulator into water as this will cause rust.

Aluminum or Stainless Steel Pots: Clean after each use according to the directions below.

Cast Iron Cookware: Clean after each use according to the directions below.

Thermometer(s): Clean after each use with mild soapy water and towel dry. Do not submerge in liquid or put in dishwasher.

Smoker Cabinet/Accessories: The grill racks and water pan should be washed with a mild soapy water solution after each use. Do not use very abrasive cleaners. They may damage the finish of the product. Wipe out wood chip pan with clean dry rag. The outside of the cooker can be wiped off as needed. Store the appliance in a protected area. Always disconnect the propane cooker from the tank. Follow storage instructions for the tank supplied by the tank manufacturer.

TIPS FOR CARING FOR ALUMINUM FRY PANS AND BOILING POTS

It is not necessary to season aluminum pots before cooking with them. Wash with a liquid dish washing detergent and towel dry.

After cooking, wash aluminum pots and fry pans in hot, sudsy detergent. If grease or black soot has cooked to the outside of the pot while cooking with your outdoor cooker, scrub the outside of the pot with a steel wool scouring pad.

DO NOT SPRAY OVEN CLEANER ON ALUMINUM POTS TO REMOVE GREASE OR SOOT. OVEN CLEANER WILL CAUSE THE FINISH TO BECOME DULL.

If food remains stuck in the pan after cooking, add hot water and let soak. Then scrub the pan with soap and steel wool to loosen the food.

If hard water causes darkening on the interior of your pot, fill to the level of the darkened area with a water and cream of tartar or vinegar solution (mixed with the concentration of three cups of water to one tablespoon cream of tartar, or vinegar). Boil five to ten minutes.

NEVER PLACE AN EMPTY ALUMINUM OR STAINLESS STEEL POT ON A LIT COOKER. A hole will be burned in the bottom of the pot. Discoloration, scratching, and dimpling may occur with the use of pots on outdoor cookers. This does not affect the performance of the pot.

Do not store used oil inside your aluminum pot. The salt used in cooking can corrode the pot causing the pot to leak. Wash the pot after each use with hot, soapy water and rinse.

SEASONING & CARE OF CAST IRON COOKWARE

New Cast Iron Pots are coated with paraffin to prevent rusting. Before using for the first time, wash with mild soapy water, rinse, and dry thoroughly. Never use abrasive detergents. Grease the entire surface of the cookware with a thin coating of solid vegetable shortening. Do not use salted fat (margarine or butter). Heat for 30-60 minutes in oven at 300-350°F (149-177°C). Remove from oven, pour out excess grease, and wipe with a paper towel. This completes the seasoning process. Each time the cast iron is used, coat the entire surface with a thin coat of solid vegetable shortening, wipe with a paper towel, and store.

INFORMATION REGARDING COOKING OIL

In our instructions we suggest peanut oil for deep frying. While this is an excellent choice, any good liquid vegetable oil may be substituted.

SUGGESTIONS FOR KEEPING USED COOKING OIL:

After initial use, let the oil cool. While slightly warm, filter out particles before storing in original container or similar sturdy plastic or glass container. This can be accomplished by using filter paper (coffee filters) or a clean cloth (dishtowel). Never pour hot oil into a container. For best results store oil in a cool place. It can be reused within 30 days. Discard after second use or when the flavor of reheated oil becomes objectionable to taste.

Helpful Hint: Try frying a batch of french fried potatoes after cooking. This aids in improving the flavor of the oil for the next use.



SECTION III RECIPES

from
The King of Outdoor Cooking™

READ AND UNDERSTAND ALL INSTRUCTIONS BEFORE USING THE PRODUCT

SMOKING

Congratulations on your purchase of your King Kooker Outdoor Propane Smoker/Cooker. You will be delighted with the variety of dishes you can prepare with your smoker. Use your imagination and you can be a gourmet chef, surprising your friends and family with the wonderful meals you will prepare. We have provided a few recipes below to get you started. Reference the “King Kooker Smoking Chart” on page 18 for estimated cooking times and temperatures. We suggest using a King Kooker Meat Thermometer or any other high quality meat thermometer to accurately test for doneness. There are a wide variety of seasonings/marinades available to experiment with and enjoy. Cook with your smoker and EAT LIKE A KING!

REMEMBER: When checking or removing food, the smoker, food and racks will be extremely HOT. Always wear protective oven mitts when handling and use caution.

Using Wood Chips To Add Flavor

Wood chips of various flavors can be added to the wood chip pan when smoking. Some choices are hickory, pecan, apple, cherry, and mesquite. Soak the wood chips for at least one hour to prevent a bitter taste. Wait to add the wood chips until only one hour of smoking time is left. This gives a pleasant flavor to the smoked food without overpowering it with the smoked flavor.

Using Marinades/Dry Seasonings to Add Flavor

King Kooker marinades and dry seasonings add succulent flavor to all types of cooking. For maximum flavor and taste, generously rub on dry seasonings and inject marinade the night before cooking or at least one hour before. Always cover food and refrigerate once seasoning/marinade is added. Marinade can also be added to the water pan as desired. Garlic Butter and Hot & Spicy King Kooker marinades do an excellent job. King Kooker Cajun and Sweet & Spicy Dry Rub seasonings are great examples of dry seasonings you can use.

Recipes for Smoked Foods

Smoked Turkey or Chicken

Ingredients : 12 - 20 lb. Turkey or 4 - 5 lb. whole fryer
King Kooker Cajun Seasoning
King Kooker Marinade (Optional)

Prepare your turkey or chicken for cooking by thawing, removing the giblet pack & neck, rinsing the bird inside & out. Pat dry with paper towels. Inject with marinade if desired. Sprinkle King Kooker Cajun Seasoning generously on the bird, inside & out. Check the Smoking Chart on page 18 for approximate time & temperatures. If you prefer to stuff your turkey or chicken, refer to stuffing recipes on the following page.

Jalapeno Corn Bread Dressing

Ingredients: 2-6 oz. packages of your favorite sweet corn muffin mix & additional ingredients as per the mix instructions.
1 tbsp. chopped canned jalapeno peppers, drained
4 oz. canned chicken broth
4 oz. water
1/2 cup chopped onions
1/4 cup chopped bell pepper
1/4 cup chopped celery
1 tbsp. chopped parsley
1/4 cup cooking oil
4 oz. can sliced mushrooms, drained
1 well beaten egg

Mix the corn bread batter as per the instructions on the package and add the jalapenos. Oven bake the corn bread and allow to cool. Use a large saucepan and your kitchen stove or an outdoor cooker to prepare the dressing. Place the cooking oil in the pot. Combine the onion, bell pepper, celery, & parsley in the pot. Saute until the onions are clear, not browned. Add mushrooms. Crumble the corn bread and stir into the onion mixture. Add the chicken broth and water. Stir over a low heat for a few minutes. Pour the well beaten egg into the mixture & stir well. This should stuff 1 turkey or 2 chickens. Refer to the stuffing directions on the bottom of this page.

Andouille Dressing

Ingredients: 18 oz. french bread stuffing mix
1/4 cup chopped bell pepper
1/2 cup chopped onion
1/4 cup chopped celery
1 tbsp. parsley
1/2 stick butter
1 lb. andouille chopped into small pieces
1 egg well beaten
1 quart of water

Use a large saucepan and your kitchen stove or outdoor cooker to prepare the dressing. Place the cooking oil in the pan. Combine the onions, bell pepper, celery & parsley in the pot and saute on low flame until the onions are clear, not browned. Add the andouille & saute for a few more minutes. Add the stuffing mix & the water. Continue to simmer while stirring in mix. Add the egg to the mixture. Stir & remove from the heat. Refer to the stuffing directions on the bottom of this page.

Oyster Dressing

Ingredients : 1 stick of butter or margarine
3 large yellow onions finely chopped
1 bunch of green onions finely chopped
2 or 3 stalks of celery finely chopped
2 tbsp. chopped parsley
5 or 6 dozen oysters, drained
1 loaf of sliced bread
Large bowl of water
2 eggs well beaten
Salt & Pepper

Use a large saucepan and your kitchen stove or outdoor cooker. Turn on low heat. Place the butter in the pan. Add the yellow & green onions, celery, and parsley to the pan and saute until the onions are clear. Add the oysters to onion mixture. Dip a slice of the bread into the bowl of water and then squeeze the excess water out of the bread. Tear the squeezed bread into pieces & drop into saucepan with onion & oyster mixture. Continue wetting & adding all bread. Stir the mixture occasionally during the process. When the entire loaf of the bread has been added, stir in the eggs. Salt and pepper to taste. Sometimes oysters are very salty. Saute for a few minutes longer & remove from heat. Refer to the stuffing directions on the bottom of this page.

Stuffing Directions

Stuff into the large cavity of the turkey or chicken and sew closed or close the opening with stuffing pins. Each recipe should adequately stuff 1 turkey or 2 chickens. Refer to the Smoking Chart on page 18 for cooking times. When done, remove the stuffing & carve the turkey or chicken.

Smoked Split Whole Chicken

Ingredients: 4-5 lb Fryer
King Kooker Sweet & Spicy Rub

Prepare your chicken for cooking by thawing, removing the giblet pack and neck, and rinsing the chicken inside and out. Pat dry with paper towels. Cut the side opposite the breast straight down the middle into the cavity (do not fully sever chicken). Generously rub in King Kooker Sweet & Spicy Rub seasoning. Place the split chicken on rack with the breast up and the rib cage against the rack. Cook according to the Smoking Chart on page 18. Test for doneness using a meat thermometer.

Smoked Ribs

Ingredients: Full Rack of Beef or Pork Ribs
King Kooker Sweet & Spicy Rub
King Kooker Barbeque Sauce (Optional)

Rinse ribs to prepare for cooking. Sprinkle Sweet & Spicy Rub generously on the ribs and rub the mixture into the meat. Arrange on the smoker rack and cook according to the Smoking Chart on page 18. For wet ribs, barbeque sauce may be added if desired when one hour of cooking time remains. Also, a second coat of sauce may be added before serving. To test for doneness, slice between the bone, see if it is tender and done to your liking.

Smoked Brisket

Ingredients: 1-Brisket (1-6 lbs.)
1-Marinade Injector
King Kooker Cayenne Garlic Marinade (or any of your favorite King Kooker Marinades)
Garlic Cloves- as desired
King Kooker Sweet & Spicy Dry Rub
Large Pan for Marinating Brisket

Rinse the brisket and pat dry with a paper towel. Inject the brisket with marinade as desired. Make small slits in the brisket and stuff with the garlic cloves. Sprinkle with King Kooker Sweet & Spicy Dry Rub and rub the mixture into the meat. Place the meat into the marinating pan and pour some marinade over the brisket. Cover the brisket in the pan and place in refrigerator to marinate overnight, or at least one hour. When ready to smoke, remove the brisket from the marinating pan and sprinkle again with King Kooker Sweet & Spicy Dry Rub. Place the brisket on the rack and cook according to the Smoking Chart on page 18. When the smoking is complete, remove the brisket from the smoker and immediately check for doneness with a meat thermometer. Slice thinly and enjoy.

Smoked Leg of Lamb

Ingredients: 3-6 lb. Leg of Lamb
Garlic Cloves- as desired
Olive Oil
Dried Rosemary

Rinse the lamb and pat dry with a paper towel. Slice small slits and stuff each slit with a garlic clove. Rub the lamb with olive oil. Sprinkle generous amounts of rosemary on the lamb. Cover with aluminum foil. Refrigerate and marinate overnight if desired. Remove from marinating pan and place on a rack for smoking. Smoke according to the Smoking Chart on page 18. When the cooking time has passed remove from smoker and immediately check for doneness using a meat thermometer.

Smoked Venison Roast

Ingredients: Venison Roast
King Kooker Garlic Butter Marinade or King Kooker Hot & Spicy Marinade
Sweet & Spicy Dry Rub

Rinse the roast and pat dry with a paper towel. Inject with the King Kooker marinade of your choice. Generously sprinkle and rub the roast with King Kooker Sweet & Spicy Dry Rub seasoning. Place the roast into a pan and cover with foil. Marinate overnight in the refrigerator. Remove from pan and place on the rack of the smoker. Cook according to the Smoking Chart on page 18. When planned cooking time has passed, remove the roast from the smoker and immediately test for doneness with a meat thermometer.

Smoked Salmon Steaks

Ingredients: Salmon Steaks, Approximately 1 1/2" Thick
King Kooker Cajun Seasoning
1 - Yellow Onion, Sliced and Separated
1 - Green Pepper, Sliced into Rings
1 - Lemon, Sliced

Cover a rack from the smoker with aluminum foil to prevent steak breakage and fish drippings. Arrange the steaks on the covered rack. Prepare your salmon by generously covering with King Kooker Cajun Seasoning on both sides. Place rings of the onion, green pepper, and lemon on top of the salmon steaks. Plan cooking time according to the Smoking Chart on page 18. At the end of the planned cooking time, remove the rack from the smoker and check for doneness. The meat should flake easily with a fork.

Smoked Butterflied Shrimp

Ingredients: Shrimp, 16-20 to the pound
King Kooker Cajun Seasoning
1 - Lemon
1 - Lime

Prepare your shrimp for cooking by thawing, if frozen, and removing the heads. Cut the shrimp down the back and butterfly. Remove the vein, leaving the shells on. Sprinkle generously with King Kooker Cajun Seasoning. Arrange individually on the rack of the smoker. Squeeze lemon and lime over shrimp before placing into the smoker. Cook for the time recommended in the Smoking Chart on page 18. When the planned cooking time has passed, remove the rack from the smoker. Check for doneness by making sure they are a pink color and that shells are separating from the meat.

Smoked Baked Potatoes

Ingredients: Potatoes, Sweet or Russet
(7 potatoes will fit on the Potato Baking Accessory Rack sold separately for use with this smoker.)
Cooking Oil

Scrub the potatoes to prepare for cooking. Puncture with the tines of a fork at various points around the potato. Rub each potato with cooking oil. Place upright on the points of a potato rack, or arrange by laying flat on a smoker rack. Cook for approximately 1 1/2 hours at 300°F (149 °C). Remove from the smoker when the cooking time has passed. Check for doneness by sticking with a fork to make sure the potato is soft enough to puncture with minimal pressure. Split and serve with butter and sprinkle with your choice of toppings.

Smoked Corn on the Cob

Ingredients: Corn on the Cob, Frozen or Fresh, with Husk and Silk Removed, and Rinsed
Butter
King Kooker Cajun Seasoning

Melt butter in a dish. Brush each ear of corn with a basting brush and sprinkle with King Kooker Cajun Seasoning. Wrap each ear individually with aluminum foil. Arrange on the smoker rack and bake at 300°F (149 °C) . Plan to cook the fresh corn for 1 1/2 hours and frozen for 1 hour. When cooking time has passed, remove the rack from the smoker and cool the corn before serving.



Other King Kooker Specialties

Boiled Seafood The King Kooker® Way!

For a 22 to 32 quart pot, fill 1/2 full of water. Add 2 to 4, 16 ounce King Kooker® Complete Crab Shrimp, Crawfish Boil (complete, nothing to add). Bring water to a rolling boil. Add seafood. Gently stir. Cover the pot and return to boil. Boiling times: Shrimp - 2 minutes; Crawfish - 5 minutes; Crabs - 5 minutes. Cut off the fire. Gently stir the seafood again and let it soak. Add 1/2 of one 8 ounce King Kooker® Liquid Crab Boil. Soaking time: Shrimp - 15 to 20 minutes; Crawfish and Crabs - 15 to 20 minutes.

Seafoods tend to float on the surface while soaking. On the surface they do not thoroughly absorb the seasoning. Add the equivalent of one tray of ice to the pot, allowing it to float on the surface of the liquid. This sudden change of temperature causes the seafood to sink and to draw in the great flavor of King Kooker® seasoning.



A Little Extra

To complement your seafood, try including a few creamer potatoes, a few ears of corn, fresh mushrooms, two or three cloves of garlic, fresh peeled onions, hot dogs, smoked sausage or andouille sausage.

Hint: Allow potatoes extra cooking time by adding them to the boiling seasoned water 5 to 10 minutes before adding the seafood.

Blackened Fish

Heat a cast iron skillet for at least ten minutes on your King Kooker®. Allow the skillet to get almost white hot -- hot enough to see the "flame circle" in the center of the skillet. This recipe produces lots of smoke.



Fish fillets should be 1/2" (1.25cm) thick for best results. Dip fillets in melted butter or margarine and shake King Kooker® Blackened Redfish Seasoning on both sides of fillets. Drop into the skillet and cook for 45 seconds on each side.

Serve piping hot.

Barbecue Shrimp



Ingredients: 2 lbs. large shrimp, 1 stick butter or margarine, 4 tablespoons King Kooker® Blackened Redfish Seasoning.

Melt butter over medium heat in a pot large enough to hold all ingredients. Add seasonings and shrimp. Cover the pot and cook for 10 minutes. Stir occasionally. Shrimp are ready when they are a pretty pink color.

King Kooker® Beans

Ingredients: 2 - 64 oz. cans of Pork & Beans, 2 - large white finely chopped onions, 1 bell pepper finely chopped, 1 - bunch of shallots finely chopped, 1/2 bunch of celery finely chopped, 1 lb. ground meat, 1 lb. sliced bacon, 1 lb. light brown sugar, 1 -8 oz. bottle of honey, 12 oz. barbecue sauce, 3 oz. King Kooker® Cajun Seasoning, Olive Oil for sauteing seasonings. Directions: Brown off the ground meat. Drain off and dispose of the fat. Set aside the ground meat. Cut the bacon into thirds. Fry the bacon. Drain off and dispose of the fat. Set aside the bacon. Pour a few ounces of olive oil into the pot. Place the onion, bell pepper, shallots and celery into the olive oil. Saute until the onions are clear. Add all remaining ingredients, including meat and bacon. Stir, cover and cook for sixty minutes over low heat. Stir often during cooking to prevent sticking.

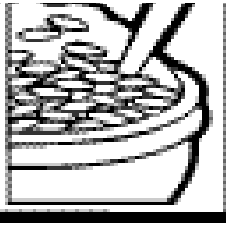

King Kooker® Jambalaya

Ingredients: 2 cans chicken broth, Tabasco, minced garlic, 4 oz. Kitchen Bouquet, 2 cans sliced mushrooms, 2 onions finely cut, 2 bell peppers finely cut, 2 lbs. smoked sausage, 1 lb. hot sausage or andouille, 8 bags of King Kooker® Jambalaya Mix, 1 lb. bacon, water.

Fry off 1 lb. bacon (cubed) in small amount of cooking oil, then remove. Brown all meat, then remove. Place onions and bell peppers into pot and cook until soft. Put all meat back in except bacon. Add chicken broth, mushrooms, Kitchen Bouquet (4 oz. bottle), minced garlic (3 to 4 tbsp.), and Tabasco Hot Sauce (6 tbsp.) Add enough water to fill 3/4 of pot and bring to slow boil. Add 8 bags jambalaya mix. Bring back to slow boil. Boil 5 minutes. Stir occasionally to prevent rice from sticking. Turn fire off, cover, and let stand 20 to 25 minutes. Makes approximately 32 servings.



Fried Seafood

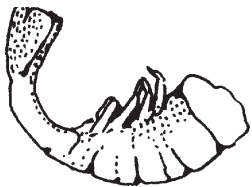

Wash and drain seafood. Remove any excess moisture, this will reduce splashing and popping in hot oil. Thoroughly coat seafood with King Kooker® Seasoned Fish Fry. Place in oil or shortening at 325 - 350°F (163-177° C) and cook until golden brown on all sides. Heavier breading may be obtained by dipping seafood in a mixture of egg and milk before coating with seasoned fish fry.

Fried Chicken

Ingredients: Chicken, oil, milk, eggs, King Kooker® Seasoned Fish Fry, skillet or aluminum pot.

Cut, wash and drain chicken pieces. Dip pieces into a mixture of beaten egg and milk. Coat with King Kooker® Seasoned Fish Fry. Heat oil to 350° F (177°C). Place chicken into oil and cook until done. Cooking outdoors with a large skillet allows for larger quantities to be prepared in less time.

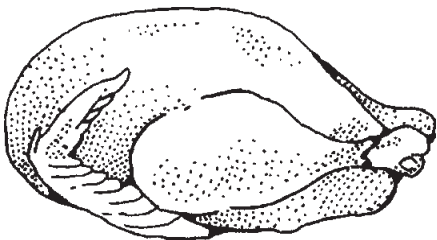

Fried Onion Rings

Ingredients: Colossal onions (if available), 2 beaten eggs, 1/2 cup milk, flour, King Kooker® Seasoned Fish Fry.

Cut onions into rings, wash and drain. Blend eggs and milk in a bowl for dipping. Dip each onion ring into egg and milk mixture, then into flour. Dip onion ring again in the egg and milk mixture, then coat with King Kooker® Seasoned Fish Fry.

Heat oil to 350°F (177°C). Drop onion rings one at a time into the heated oil. When the rings float to the top, remove from oil. Serve warm.

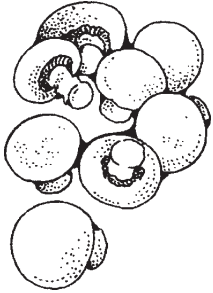
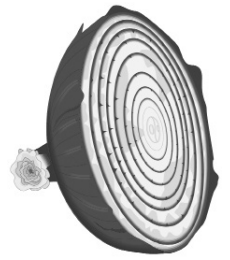

Fried Mushrooms

Ingredients: Mushrooms, water, oil, King Kooker® Seasoned Fish Fry.

Slice mushrooms 1/8" (.32 cm) thick and submerge in water to wet the slices. Coat slices thoroughly with King Kooker® Seasoned Fish Fry. Heat oil to 350°F (177°C). Place the mushroom slices into heated oil. When the mushroom slices float to the top, remove from oil. Serve warm.

King Kooker® Wings

Ingredients: 3-5 lb. thawed and dried wings, King Kooker® Cajun Seasoning, cooking oil, Wing Sauce of flavor of choice.

Heat the cooking oil to 325°F (163°C). Coat the wings with King Kooker® Cajun Seasoning. Place some of the wings carefully into the heated cooking oil. Cook until the wings float and appear done. Remove the batch from the grease carefully with a skimmer long enough to keep hands away from hot oil. Check a wing for doneness. If done, add a few more wings to cook the next batch. Always monitor the temperature of the oil to keep it at 325°F (163°C). After removing the wings from the oil, dip them into the wing sauce of choice.

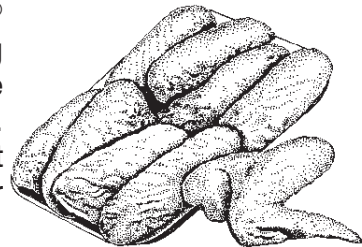

Steamed Clams or Mussels

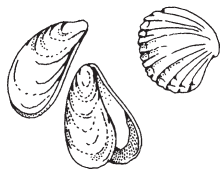

Clean clams thoroughly in cold water, scrubbing with a brush. Discard any that float. Place clams on steamer plate in basket. Pour enough water into pot to come up to bottom of steamer rack when in pot. Bring water to a boil and cover. The clams are cooked when the shells open. Any shells which do not open should be discarded. Remove from heat. Too much cooking will toughen the clams. Serve with drawn or melted butter.

Steamed Blue Crabs, Shrimp, or Lobsters



Place water in the pot up to the bottom of the steaming plate. You can add half of a gallon of the water with 1/2 gallon of vinegar if you would like. Add 2 1/2 tablespoons of steamer seasoning and 3 tablespoons salt to water/vinegar mixture. Place the steamer rack into the pot and layer the seafood on the steamer rack, sprinkling each layer generously with steamer seasoning. Salt to taste. Cover and steam until crabs or lobsters turn red (approximately 20-25 minutes). Steam shrimp (approximately 10-15 minutes), the meat will pull away from the shell when done. For extra flavor pour two ounces of King Kooker® Liquid Crab Boil into the water/vinegar mixture. (Make sure to never allow all of the steaming liquid to evaporate. A hole will be burned into the bottom of an empty pot on a lit cooker.)

We recommend King Kooker® Complete Crab, Shrimp, Crawfish Boil to add flavor to all your steamed seafoods and vegetables.

SECTION IV

READ AND UNDERSTAND ALL INSTRUCTIONS BEFORE USING YOUR KING KOOKER® PRODUCT

FREQUENTLY ASKED QUESTIONS AND ANSWERS

1. **What is the problem if the cooker takes too long or will not heat oil or cooking ingredients to desired temperature? My cooker's flame appearance is very weak.**

Answer: If the hose assembly has a Type 1 Connection (black/green knob), it is equipped with a flow limiting device. This device is intended to limit the flow of gas should there be a leak between the regulator and the appliance. To achieve a positive gas seal, which will allow for maximum gas flow, the regulator control must be set to a completely OFF position before the cylinder valve is opened. A good tip to remember is "TANK IS FIRST ON, LAST OFF."

The Problem Can Be Remedied in Two Ways:

- A.
1. Turn the regulator control to the OFF position. Close the tank valve completely by turning it clockwise until it stops.
 2. Check that the Type 1 Connection (black/green knob) is completely tightened to the tank valve.
 3. Wait 5 seconds for the pressure to equalize and for the flow limiting device to reset.
 4. Turn tank valve ON (counterclockwise.)
 5. Turn the regulator control to an ON position.
 6. Relight cooker following all lighting instructions contained in this manual. Check for proper flame characteristics.

OR

- B.
1. Turn the regulator control to the OFF position. Close the tank valve completely by turning it clockwise until it stops.
 2. Remove Type 1 Connection (black/green knob) from the tank valve. The flow limiting device will now reset.
 3. Re-attach Type 1 Connection (black/green knob) to the tank valve. Tighten completely.
 4. Turn tank valve ON (counterclockwise.)
 5. Turn the regulator control to an ON position.
 6. Relight cooker following all lighting instructions contained in this manual. Check for proper flame characteristics.

2. **How long will the propane in my tank last?**

Answer: On average, a full tank will give you 4 to 5 hours of normal cooking.

3. **I have a new style tank and it won't connect to my regulator. What do I do?**

Answer: The regulator supplied with this appliance has a Type 1 Connection which will attach to the tank valve which has large threads on the valve outlet. These connect into the large plastic handnut (black or green). This tank will also connect to earlier models of Metal Fusion cooker regulators which had a brass plug connector with left hand threads, which will connect to the internal threads of the Type 1 tank valve (with a wrench). If your tank has a quick disconnect valve (plug in type) our regulators can not connect to this tank.

4. **I have a brand new cooker and I cannot get the burner to light. What's the problem?**

Answer: Make sure the tank has been filled with propane. Tanks purchased from the store shelf are most often sold empty. If this does not solve the problem refer to Maintenance Instruction items #3 and #4, page 19. If you have questions please call Metal Fusion, Inc. at (800) 783-3885.

**IF YOU HAVE A QUESTION WE HAVE NOT ADDRESSED IN THIS MANUAL
PLEASE SEND US AN E-MAIL AT info@kingkooker.com OR CALL 1-800-783-3885
BETWEEN 7:30 A.M. AND 3:30 P.M. CST MONDAY THROUGH FRIDAY.**

Outdoor Cooker Safety Precautions

WARNING!

FAILURE TO FOLLOW THESE INSTRUCTIONS AND WARNINGS COULD RESULT IN FIRE, EXPLOSION, BURN HAZARD OR CARBON MONOXIDE POISONING WHICH COULD CAUSE PROPERTY DAMAGE, PERSONAL INJURY OR DEATH.

Read and understand the entire Assembly Instructions and Use and Care Manual before using this product. If you lose your manual and need a replacement, or have questions, please contact us at 1-800-783-3885 between the hours of 7:30 A.M. and 3:30 P.M. CST Monday-Friday, or go to www.kingkooker.com

WARNING: This Product Contains, and Its Use Will Create Chemicals Known to The State of California to Cause Cancer and Birth Defects (Or Other Reproductive Harm).



USE ONLY OUTDOORS!



DO NOT use under any overhang or roof. Keep a minimum clearance of 10 ft. (3.05m) on all sides of the cooker or smoker.



DO NOT use on combustible surfaces.



ALWAYS keep children, pets and any unauthorized persons away from the cooker or smoker.



ALWAYS use a deep fry thermometer to monitor the temperature of the grease while frying and preheating.



NEVER LEAVE COOKER OR SMOKER UNATTENDED while in use or still hot.



ALWAYS wear shoes while cooking. Keep hair and clothing from coming into contact with the cooker or smoker while in use or still hot.



ALWAYS wear protective mitts and use extreme caution not to splash hot oil.



NEVER cover the pot while frying or preheating.



ALWAYS turn the burner **OFF** when cooking is complete.



ALWAYS thaw and dry food completely before cooking with oil or grease.

KING GRILLERDINE, KING KOOKER®, the KING KOOKER® logo, THE KING, THE KING OF OUTDOOR COOKING, MR. OUTDOORS, and WATCHDOG OUTDOOR COOKER SERIES are trademarks of Metal Fusion, Inc., 712 St. George Avenue, Jefferson, LA 70121