

TIPS FOR SLOTTED DECKING INSTALLATION USING HIDDEN FASTENERS

Notice to installers

- 305 stainless steel, black head screws
- DO NOT use cordless impact drivers
- Set drill speed 1500-1750 RPM
- Max torque not to exceed 23 inch pounds
- Pre-drill knots or dense hardwood

Always wear safety glasses when using power tools.

Items you will need

- Drill/power screwdriver
- 1/8" drill bit
- Circular saw with carbide-tip blade
- Assorted fasteners (see instructions)
- Tape measure
- Carpenter's pencil
- Safety glasses/goggles

Coverage

- 87 pieces of hidden fasteners will install:
- 50 sq. ft. of 6" wide (5-1/2" actual) deck boards on 16" centers, or
 - 43 sq. ft. of 6" wide (5-1/2" actual) deck boards on 12" centers

The appearance of slotted composite decking changes when viewed from different ends. To achieve the most consistent color, install all of the boards in the same direction using the product end tags (A) as a point of reference. Installing boards in opposing directions will create contrasting light and dark shades of the deck board color and is not covered under warranty.



(A) end tag

Prior to construction, check with your local regulatory agency for special code requirements in your area. For best results, follow these simple installation instructions, paying close attention to gapping, spacing and fastener requirements. **Joist span:** Depending on local building code requirements, refer to ESR-1573 or CCMC 13378-R for joist spacing and stair tread support options. Contact product support at 877-463-8379 for information on commercial applications.

Board end to board end gapping requirements

figure 1

Temperature °C on day of installation	Warmest annual temperature °C expected in region											
	°C	-7	-1	4	10	16	21	27	32	38	43	49
	-7	1/8	1/8	1/8	1/8	1/8	1/8	3/16	3/16	1/4	1/4	5/16
-1		1/8	1/8	1/8	1/8	1/8	1/8	3/16	3/16	1/4	1/4	5/16
4			1/8	1/8	1/8	1/8	1/8	1/8	3/16	3/16	1/4	1/4
10				1/8	1/8	1/8	1/8	1/8	1/8	3/16	3/16	1/4
16					1/8	1/8	1/8	1/8	1/8	1/8	3/16	3/16
21						1/8	1/8	1/8	1/8	1/8	1/8	3/16
27							1/8	1/8	1/8	1/8	1/8	1/8
32								1/8	1/8	1/8	1/8	1/8
38									1/8	1/8	1/8	1/8
43										1/8	1/8	1/8
49												1/8

Side gapping: 1/4". **End-to-end spacing:** Allow a minimum of 1/16" gap between board ends for every 11° C of difference between installation temperature and the hottest temperature expected (figure 1). For any decking where two boards meet end-to-end over a joist, add additional blocking (figure 2). Allow 1/4" distance between all decking material and any permanent structure or post. After all of the decking has been attached, snap a chalk line (white or yellow chalk recommended) flush with or up to 1-1/2" out from the deck framing and trim with a circular saw.

All wood and composite decking products require proper ventilation and drainage to ensure their longevity. When using a minimum 2x6 joist standing on edge and the suggested 1/4" side gap, there should be a 2" clear space between the bottom edge of the joists and grade in order to allow for proper ventilation. Adequate drainage is also needed to prevent water from pooling under the deck.

Fasteners

Fasteners should fit into the slot on each side of the deck board to eliminate pre-drilling and provide a timeless, fastener-free deck surface. The deck boards require traditional fasteners on the outside and inside edges of the deck.

Begin by fastening the outside edge of the first board to the rim at every joist. For this, we recommend using 2-1/2" corrosion-resistant, composite wood deck screws. These screws help minimize the common "mushroom" effect that sometimes occurs when using standard fasteners. It can also reduce the amount of pre-drilling and countersinking.

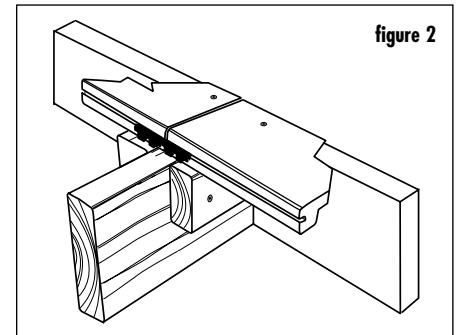
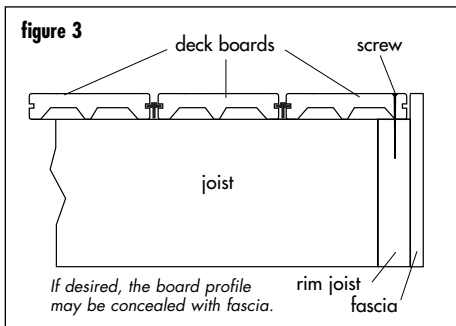

figure 2

Fasten the outside edge of the first board to the rim joist with screws. Pre-drill and countersink all deck screws, regardless of type, that are within 1-1/2" of the end of the deck board. On the other side of the board, place a hidden fastener into the slot and center on the joist.

If using ordinary coarse-thread deck screws, always pre-drill a pilot hole and countersink prior to driving screws. Screws should be driven flush with the surface. Do not over-tighten. Use one fastener per board at every joist. For any decking where two boards meet end-to-end over a joist, add additional blocking. Always pre-drill a pilot hole when fastening within 1-1/2" of board ends, whether using composite or wood screws. Do not over-tighten screws at board ends.

TIPS FOR SLOTTED DECKING INSTALLATION, CONTINUED



On the other side of the board, place a hidden fastener into the slot and center on the joist (figure 3). Install a #7, 1-5/8" stainless steel screw at a 90° angle through the fastener and drive flush. Do not over-tighten. The fastener wings must remain level with the joist for the next board to fit correctly (figure 4). Install one fastener at each joist location. Slide the next board into place so the wings on the previous fasteners fit into the slot on the side of the board. Make sure the side gap between the boards is 1/4".

To keep the interior boards from moving over time, we recommend pinning the boards at the center of their length using a #7, 1-5/8" stainless steel screw. This holds the deck board in

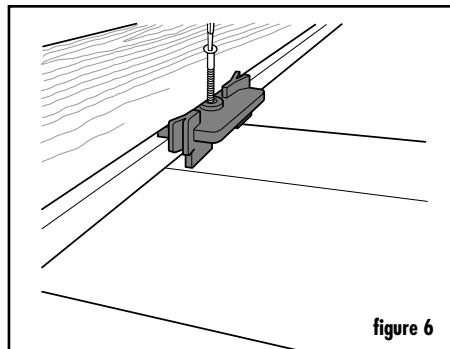

place at the center of each board and allows the decking to expand/contract at the ends of the boards. Pre-drill in the slot of the deck board with an 1/8" drill bit (inset of figure 5). Drive screw into the slot so it's flush with the bottom of the groove (figure 5). This will allow you to properly fit a hidden fastener into the slot. Install hidden fastener clip over the screw and centered over the joist. Fasten using a #7, 1-5/8" stainless steel screw at a 90° angle through the hidden fastener and drive flush with the clip (figure 6). The fastener wings must remain level with the joist for the next board to fit correctly (figure 4).

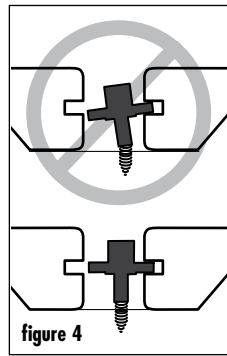

Install one fastener at each joist location along the length of the board. For installations where deck boards are butted end-to-end at the joist, we recommend adding an 8" block and using a hidden fastener clip at the end of each board (figures 7 and 8). Be sure to gap the

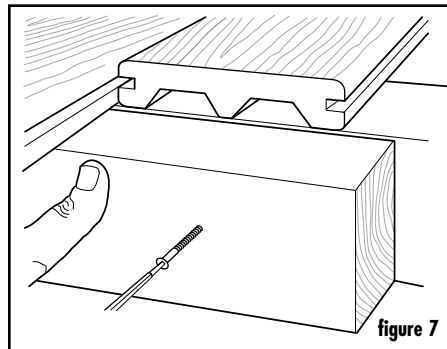

boards as previously described. Repeat the process for each board until the outside edge of the final board is fastened with screws. Use fascia to conceal the board profile and inhibit board movement over time. If no fascia is being used, the entire perimeter of the deck should be fastened to the rim joist with screws. Use two fasteners at the end of each board.

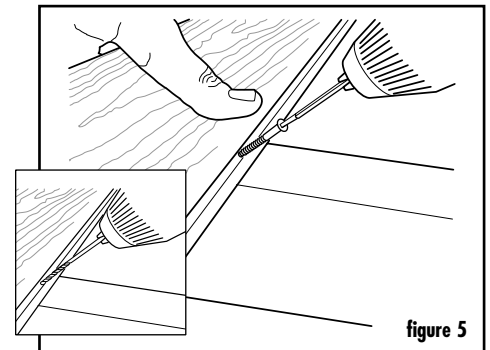

These screws will be inconspicuous once the railing is installed.

Apply these same principles when installing stair treads.

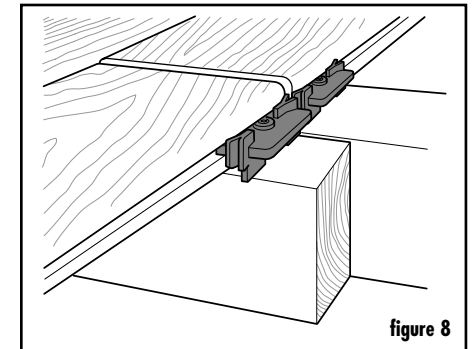

Color variation: Most composites will have color variations from piece to piece. This is due to naturally occurring variations in wood fibers and polymers. Purchasing all required decking material at one time is recommended, as manufacturing runs can produce slightly different colors. Do not install if color variation is not acceptable. Composite Decking will lighten over time, and color variation is not covered by the warranty. This color-tone shift is dependent upon exposure to sunlight and other environmental factors, and is generally completed in 60 to 90 days. Gray products may turn a light brown before changing to lighter gray. **Preventing mold and mildew growth on composite decking:** Mold and mildew can be a nuisance on any exterior building surface, regardless of the material. If the conditions are right, they will spawn on wood, plastic, concrete, metal and other surfaces. Mold formation is most prevalent in consistently wet, shaded areas. Spores from the natural environment are carried by the wind and commonly land on decks surfaces. It is important to note that the appearance of mold/mildew is a function of nature, not necessarily a deficiency with any of the material on which it grows. **Cleaning:** Periodic washing with soap/detergent and water will help remove surface dirt. This will also help prevent the buildup of pollen, debris and spores that can cause and accelerate mold/mildew growth. **CAUTION:** A pressure washer should not be used to "blast" mold/mildew or soils from a deck surface. The abrasive nature of the water stream can potentially damage the material by driving the spores into the material, which may create a more challenging problem to remediate. A pressure washer with a fan-tipped nozzle should be used only to lightly wet or rinse wood or composite deck surfaces. There are many deck wash and exterior cleaning products available at retail. It is important to make sure you use a cleaner specifically intended for your application. After selecting a product, be certain to read, understand and follow all instructions supplied by the manufacturer. Some cleaning products and inhibitors may be more effective than others, depending on the environmental conditions your deck is subjected to. Additionally, it is always a good idea to test the cleaner in a small, inconspicuous area prior to applying it to the entire deck. **Mold inhibitors:** As with deck washes, there are several mold-inhibitor products available from paint stores, hardware stores, online outlets and home centers to help prevent long-term mold/mildew growth. For any product selected, be certain to read, understand and follow all instructions provided by the manufacturer. Depending upon the environmental factors affecting your deck, some preventive cleaning products may be more effective than others. It may be necessary to try more than one product. For ongoing preventive maintenance, follow the manufacturer's recommendation.

Composite Decking is not suitable for structural use. It should not be used for primary load-bearing members such as posts, joists, beams or stringers. The same common-sense precautions should be taken when handling Composite Decking as with wood or other building materials. Dust masks and eye protection devices are recommended to avoid possible irritation from sawdust and chips. Gloves will help to protect the hands. Hands should be washed after doing construction work. The diagrams and instructions in this brochure are for illustration purposes only and are not meant to replace a licensed professional. Any construction or use of the product must be in accordance with all local zoning and/or building codes. The consumer assumes all risks and liability associated with the construction or use of this product. The consumer or contractor should take all necessary steps to ensure the safety of everyone involved in the project, including, but not limited to, wearing the appropriate safety equipment. EXCEPT AS CONTAINED IN THE WRITTEN LIMITED WARRANTY, UNIVERSAL CONSUMER PRODUCTS, INC., DOES NOT PROVIDE ANY OTHER WARRANTY, EITHER EXPRESS OR IMPLIED, AND SHALL NOT BE LIABLE FOR ANY DAMAGES, INCLUDING CONSEQUENTIAL DAMAGES.