

HO872100TX/HO872200TX

Alaska Desk - Oak/Grey

Assembly Instructions



**Southern
ENTERPRISES**

For assistance with assembly contact:

Southern Enterprises Inc.

Customer Service 1-800-633-5096

service@seidal.com

www.seidal.com

PO# 13412

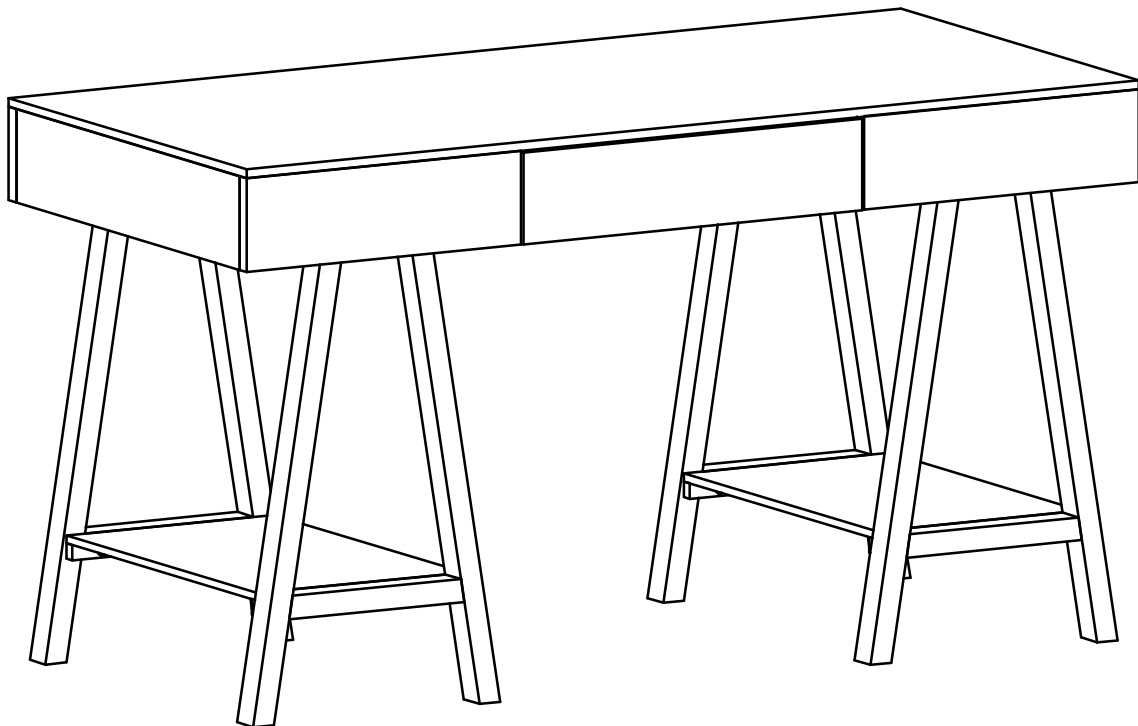

HO872100TX/HO872200TX









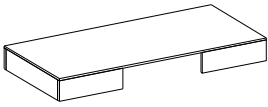
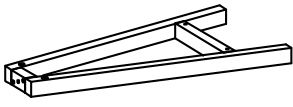
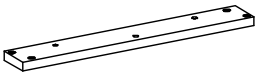
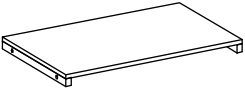
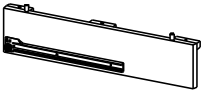
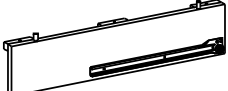
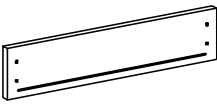
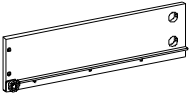

Alaska Desk – Oak/Grey

Parts List

Please review all parts and hardware before disposing of any packaging.

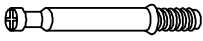
Call Customer Service if missing hardware. Carefully study the

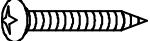
diagrams below. You may receive extra hardware with your unit.

<p>A</p> <p>Quantity Of 1</p>  <p>Top</p>	<p>B</p> <p>Quantity Of 4</p>  <p>Leg Frame</p>	<p>C</p> <p>Quantity Of 2</p>  <p>Support Bar</p>	<p>D</p> <p>Quantity Of 2</p>  <p>Shelf Panel</p>	
<p>E</p> <p>Quantity Of 1</p>  <p>Left Drawer Support Panel</p>	<p>F</p> <p>Quantity Of 1</p>  <p>Right Drawer Support Panel</p>	<p>G</p> <p>Quantity Of 1</p>  <p>Drawer Front</p>	<p>H</p> <p>Quantity Of 1</p>  <p>Drawer Left Side</p>	
<p>I</p> <p>Quantity Of 1</p>  <p>Drawer Right Side</p>	<p>J</p> <p>Quantity Of 1</p>  <p>Drawer Back Panel</p>	<p>K</p> <p>Quantity Of 1</p>  <p>Drawer Bottom Panel</p>	<p>1</p> <p>Quantity Of 8</p>  <p>Long Bolt (Ø1/4 x 2")</p>	<p>2</p> <p>Quantity Of 16</p>  <p>Medium bolt (Ø1/4 x 1-3/8")</p>
<p>3</p> <p>Quantity Of 12</p>  <p>Small Bolt (Ø1/4 x 1")</p>	<p>4</p> <p>Quantity Of 4</p>  <p>Cam Bolt Ø1/4"x 1-7/16"</p>	<p>5</p> <p>Quantity Of 4</p>  <p>Cam Lock Ø1/2"x3/8"</p>	<p>6</p> <p>Quantity Of 4</p>  <p>Screw Ø1/6"x1"</p>	<p>7</p> <p>Quantity Of 1</p>  <p>Allen Wrench</p>

Care and Cleaning Instructions:

Before using, wipe with a clean, dry cloth.
Periodically apply furniture wax to renew the finish.
Avoid rubbing or scratching the surface with rough or
abrasive objects.

For replacement parts or questions, please call
Customer Service at 1-800-633-5096.

Assembly Tool Required
Phillips and Flat Head Screwdriver

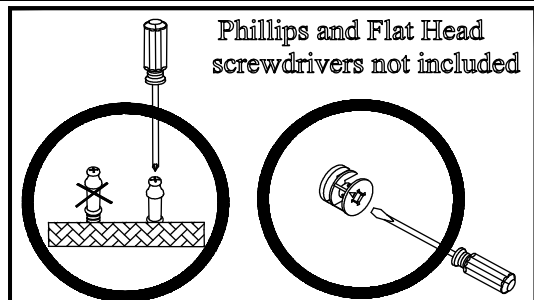

HO872100TX/HO872200TX

Alaska Desk – Oak/Grey

Assembly Instructions

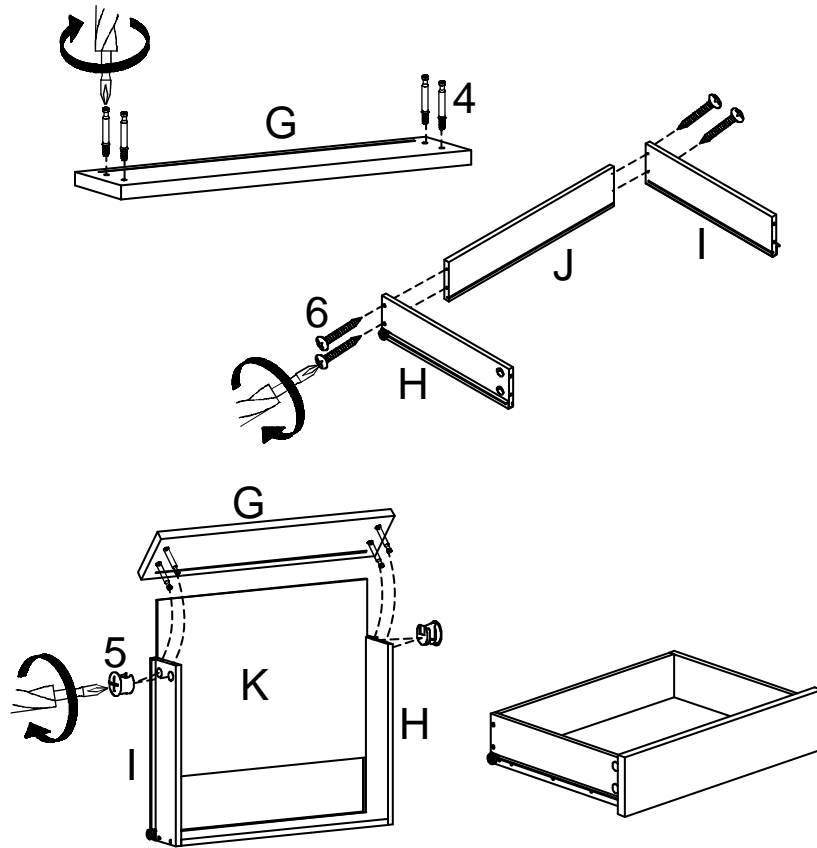

Step 1:

Attach Cam Bolts (4) to Drawer Front (G) using Phillips Screwdriver.

Attach Drawer sides (H) and (I) to Drawer Back (J) using Screws (6). Tighten with Phillips Screwdriver as shown.

Insert Drawer Bottom Panel (K) into the grooves of Drawer Sides (H) and (I).

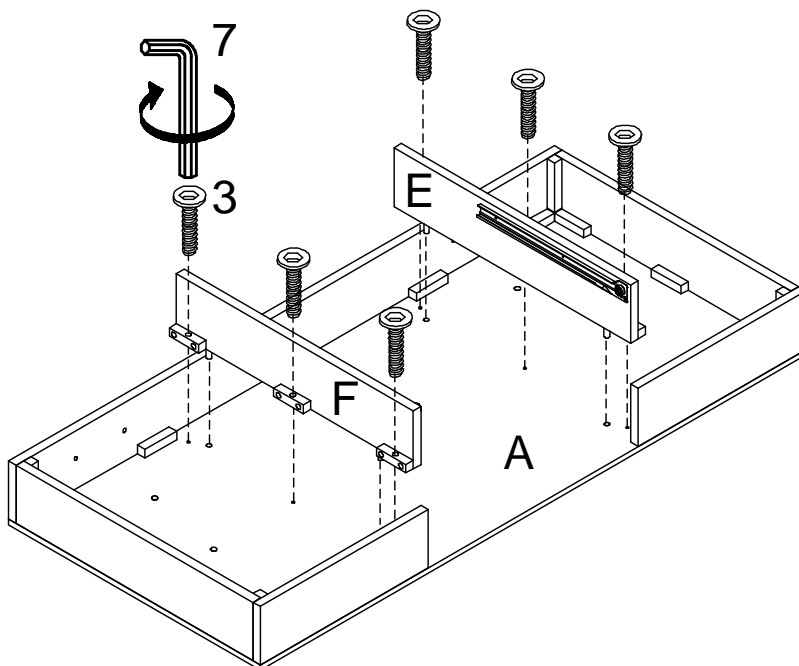

Step 2:

Attach Drawer Support Panels (E) and (F) to Top (A) using Small Bolts (3).

Tighten with Allen Wrench (7) as shown.

HO872100TX/HO872200TX

Alaska Desk – Oak/Grey

Assembly Instructions

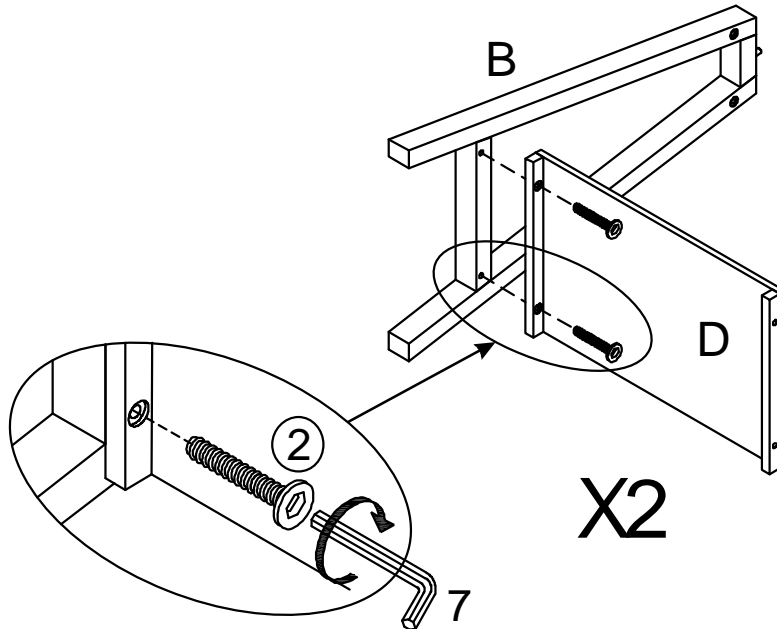

Step 3:

Attach Shelf Panel (**D**) to Leg Frame (**B**) using Medium Bolts (**2**).

Tighten with Allen Wrench (**7**) as shown.

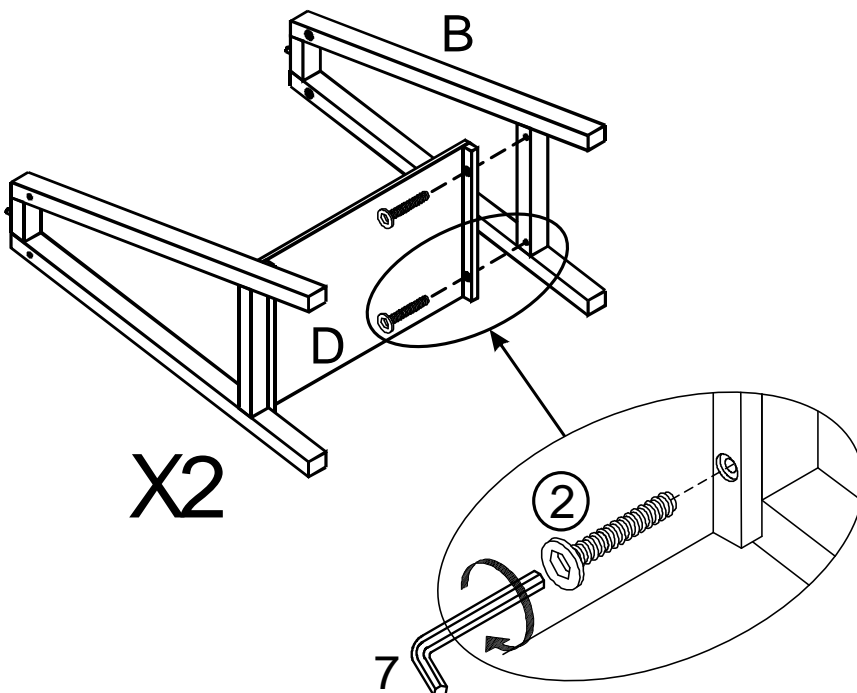

Step 4:

Attach Shelf Panel (**D**) to Leg Frame (**B**) using Medium Bolts (**2**).

Tighten with Allen Wrench (**7**) as shown.

Repeat step (**3**) and (**4**) to complete the second set of Legs.

HO872100TX/HO872200TX

Alaska Desk – Oak/Grey

Assembly Instructions

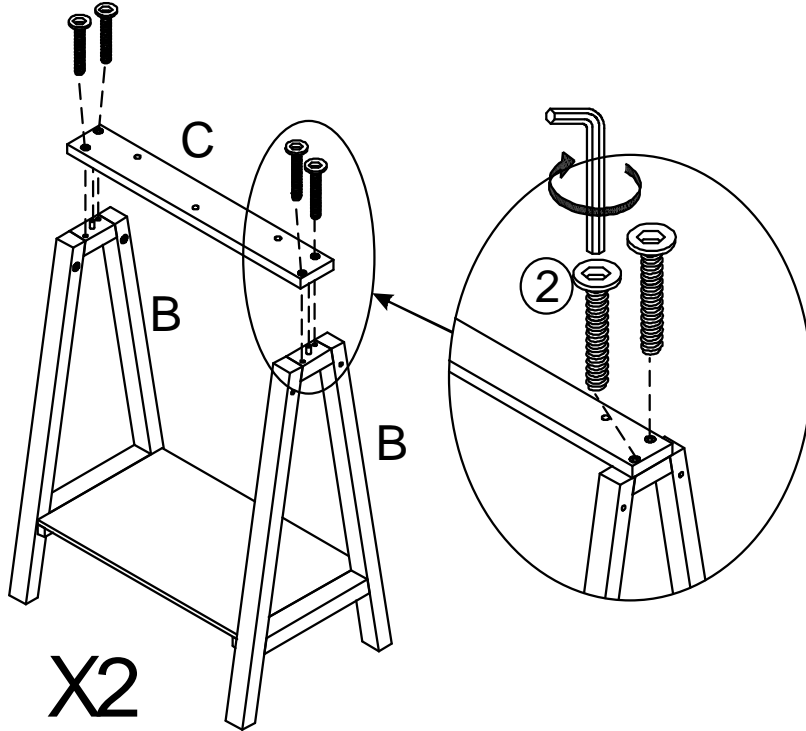

Step 5:

Attach Support Bars (C) to Leg Frames (B) using Medium Bolts (2).

Tighten with Allen Wrench (7) and repeat step for the second set of Legs.

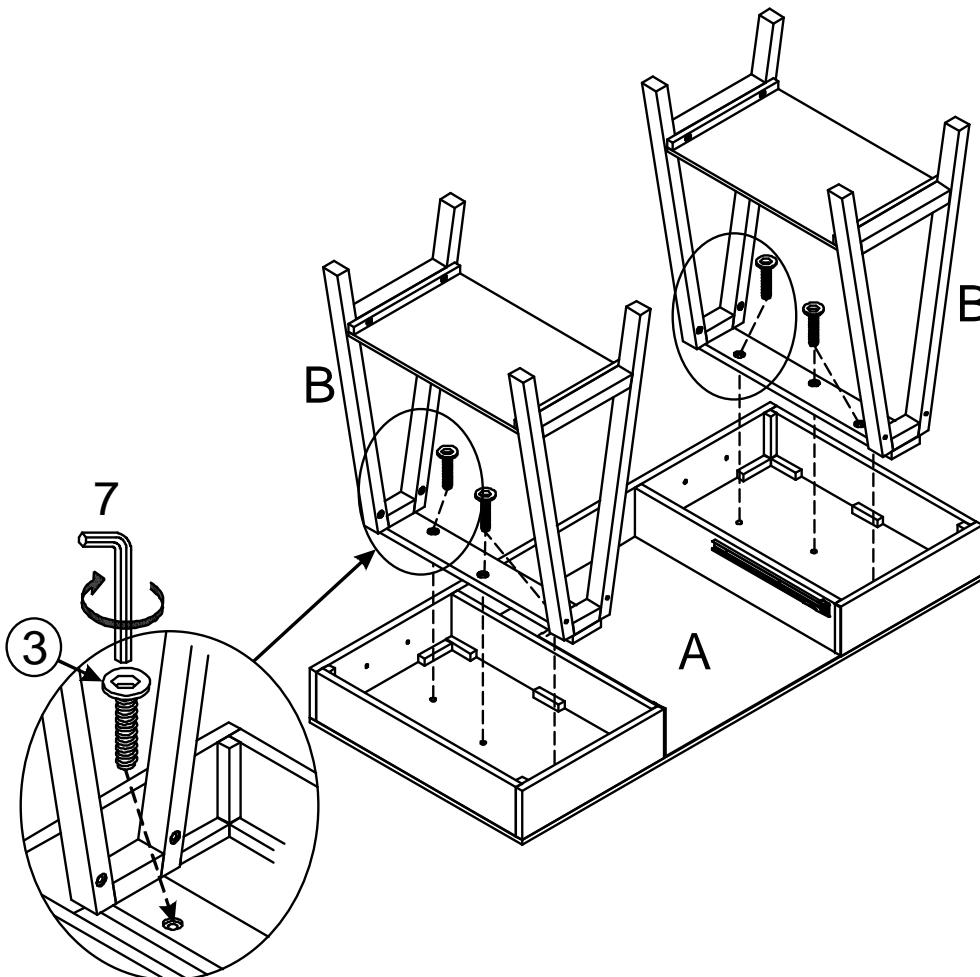

Step 6:

Attach Leg Frames (B) to Top (A) using Long Bolts (3).

Tighten using Allen Wrench (7) as shown.

HO872100TX/HO872200TX

Alaska Desk – Oak/Grey

Assembly Instructions

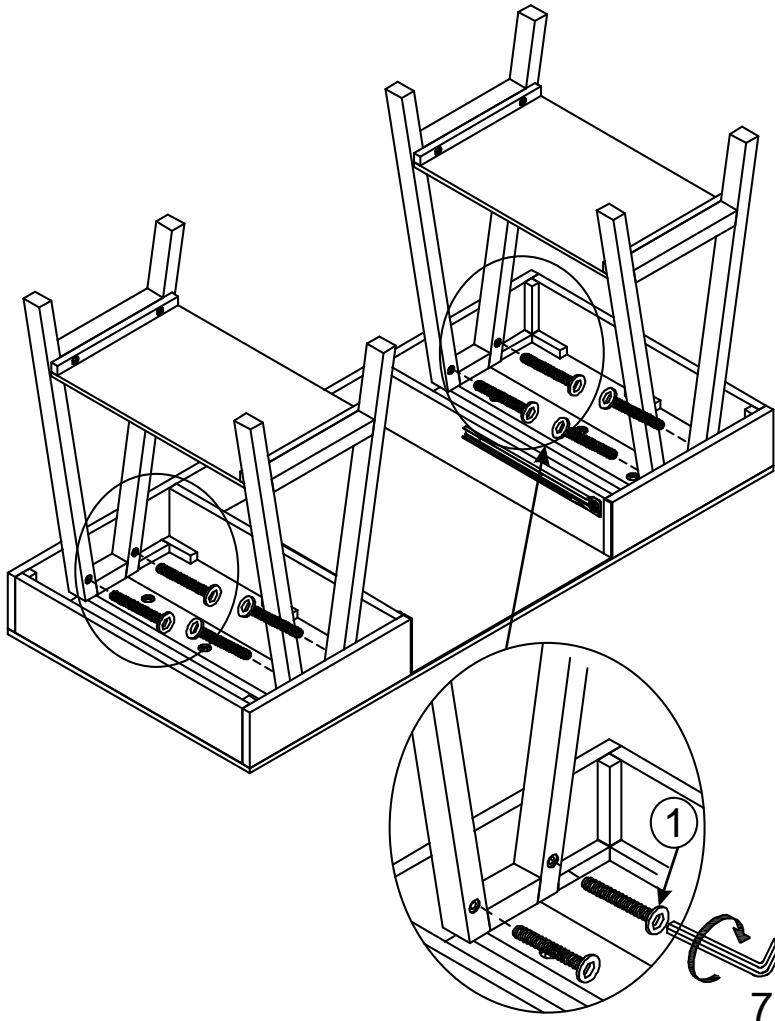

Step 7:

Use Long Bolts (1) to secure Leg Frames (B) to Top (A).

Tighten using Allen Wrench (7) as shown.

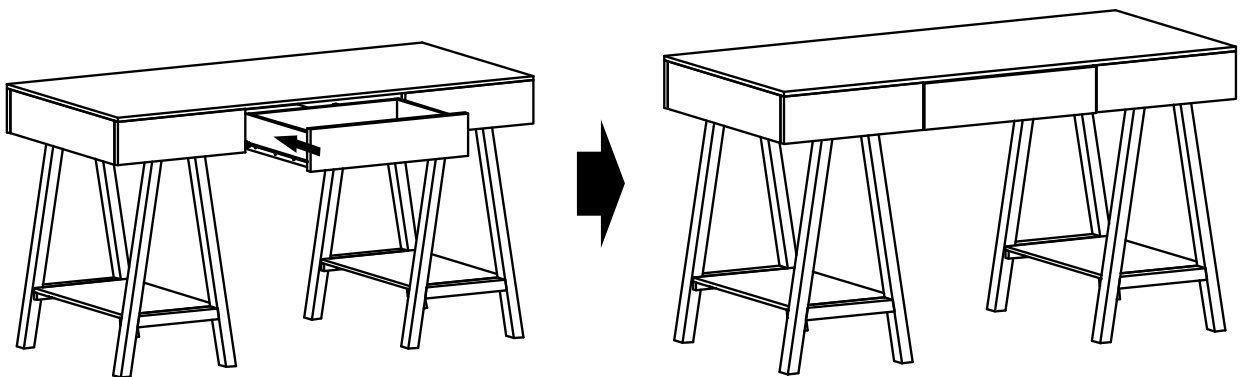

Parts Replacement Form

Customer Information

Name _____

Address _____

City/State/Zip Code _____

Phone Number _____

Please indicate where you purchased this item: Store/Website/Catalog

Please indicate color/size/style number:

Style No	Parts Letter	Parts Description
Quantity Needed		

Please immediately examine this product carefully. Any request for missing parts or damage replacement must be received within 90 days of your receipt of the product. Replacement, if available, will be honored within this time frame. Parts will not be available for items arriving fully assembled.

We do not recommend modifying product(s) and we are not responsible for any damages due to product modification(s). If damages or missing parts are not reported within 90 days of your receipt, we are under no obligation to provide parts or replacement merchandise.

Please contact Southern Enterprises at 800-633-5096 or in Dallas 972-869-0111/ 9am – 4pm Mon-Fri Central time if you have product issues or email us at service@seidal.com. Please ask for customer service representative for issues involving damages or replacement parts. Please ask for technical assistance representative for any issues with product and assembly/construction.

Please contact the retailer that you purchased from for returns.



Southern
ENTERPRISES

Customer Service

1-800-633-5096

service@seidal.com

Southern Enterprises, Inc.

600 Freeport Parkway, Suite 200

Coppell, Texas 75019