

HO967800TX

Tilt-Top Drafting Table Assembly Instructions



Southern
ENTERPRISES

For assistance with assembly contact:
Southern Enterprises Inc.
Customer Service 1-800-633-5096
service@seidal.com
www.seidal.com



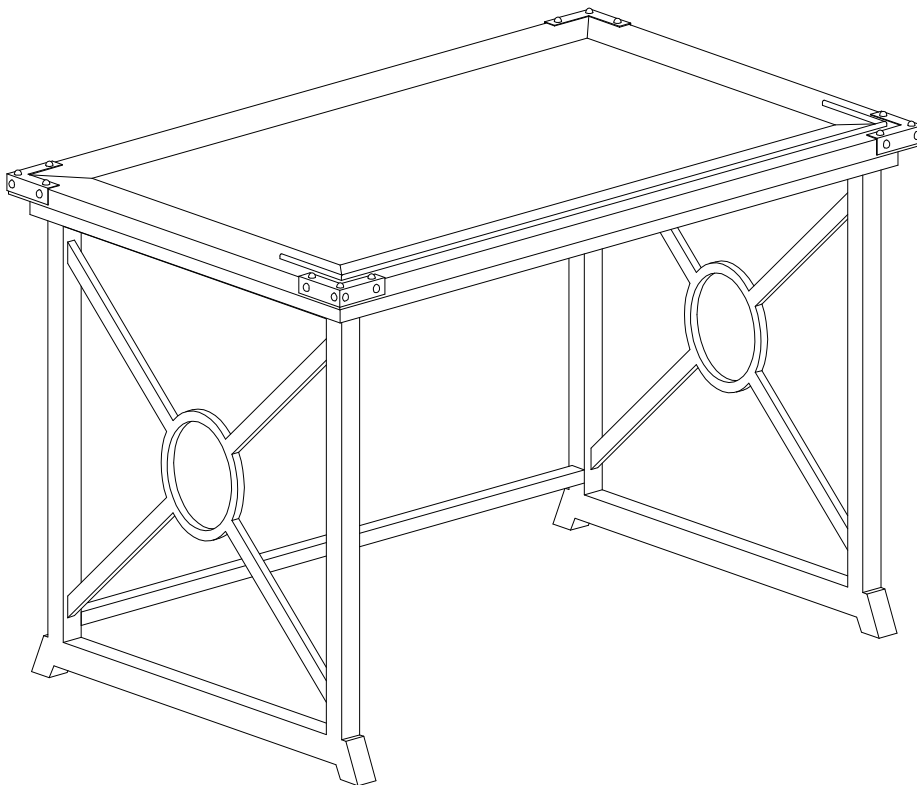

PO#

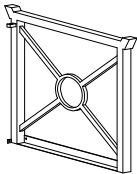
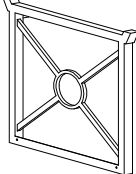

Tilt-Top Drafting Table

Parts List

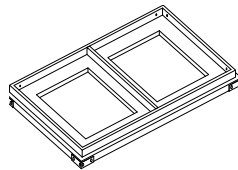
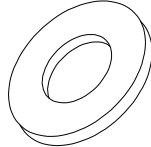
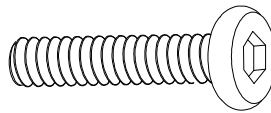
Please check packaging for all parts and hardware before discarding. Unpack and lay parts on clean, padded surface like carpet or blanket. Check that you have all parts indicated. Call customer service if hardware is missing. Before beginning assembly, carefully study the diagrams below and sort your hardware according to the pictures. Using the incorrect hardware will cause damage.

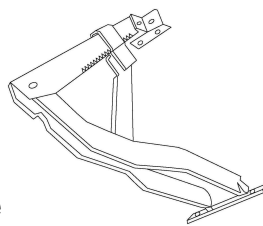
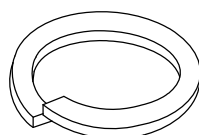
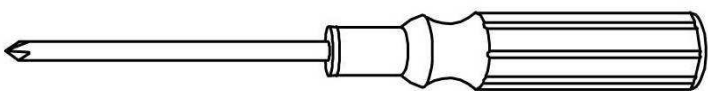
A  Left Frame Quantity of 1	B  Right Frame Quantity of 1
C  Bar Quantity of 1	D  Top Frame Quantity of 1
1  Flat Washer Quantity of 16	2  Bolt Dia 1/4" x 3/4"L Quantity of 16
3  Allen Wrench Quantity of 1	4  Anti-Slip Hinge Quantity of 2
5  Spring Washer Quantity of 16	
Care and Cleaning Instructions: Before using, wipe with a clean, dry cloth. Periodically apply furniture wax to renew the finish. Avoid rubbing or scratching the surface with rough or abrasive objects.	Call customer service at 1-800-633-5096 for assistance, questions, or parts.
Assembly Tool Required No.2 Phillips Screwdriver Not Included	

Tilt-Top Drafting Table

Assembly Instructions

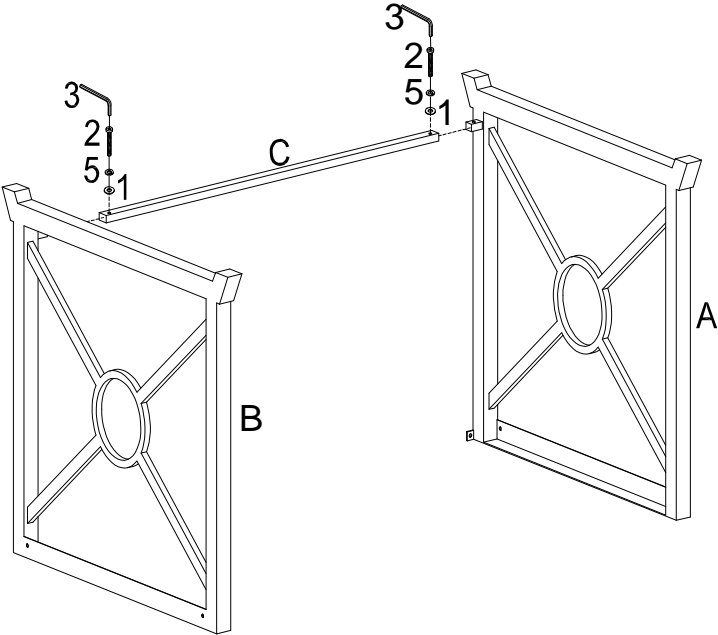

Figure 1

Attach left frame (A) and right frame (B) to bar (C) by using bolts (2), spring washers (5), and flat washers (1).

Tighten bolts (2) with Allen wrench (3) as shown.

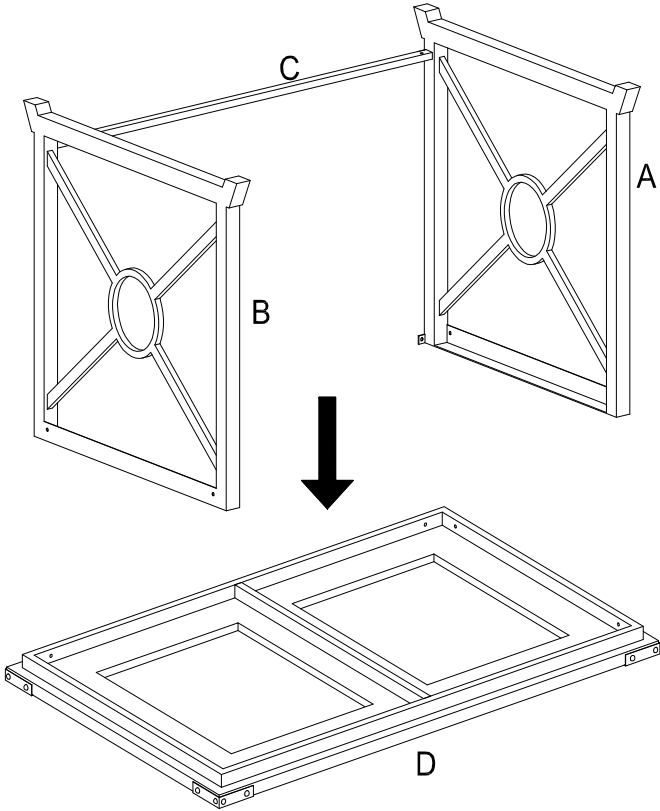

Figure 2

Attach assembled unit to top frame (D) as shown.

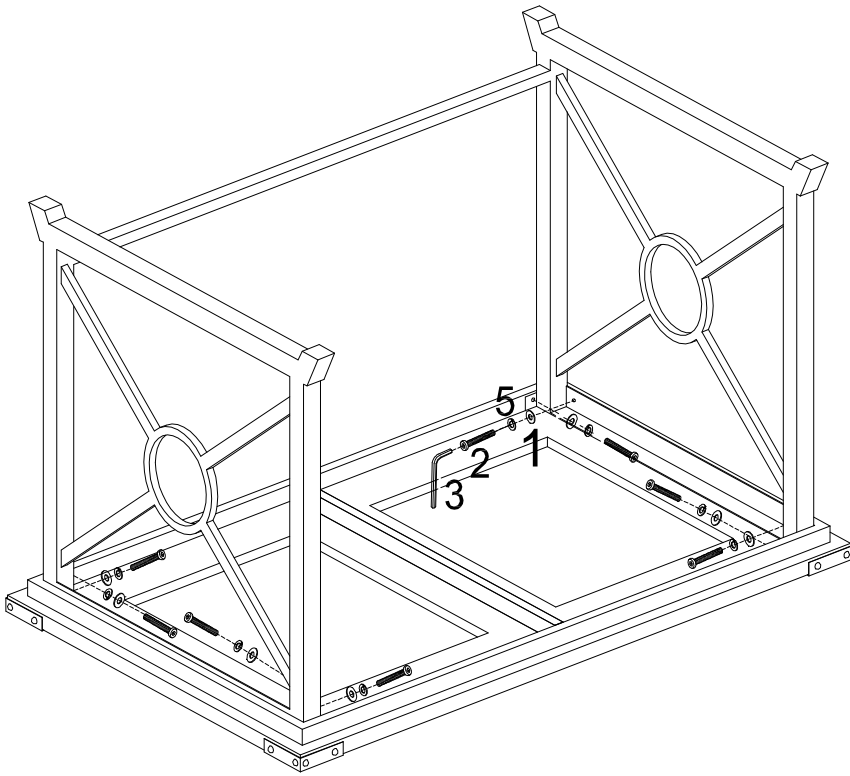

Figure 3

Insert bolts (2) through spring washers (5) and flat washers (1) to connect assembled unit from figure 1 to top frame (D).

Tighten bolts (2) with Allen wrench (3).

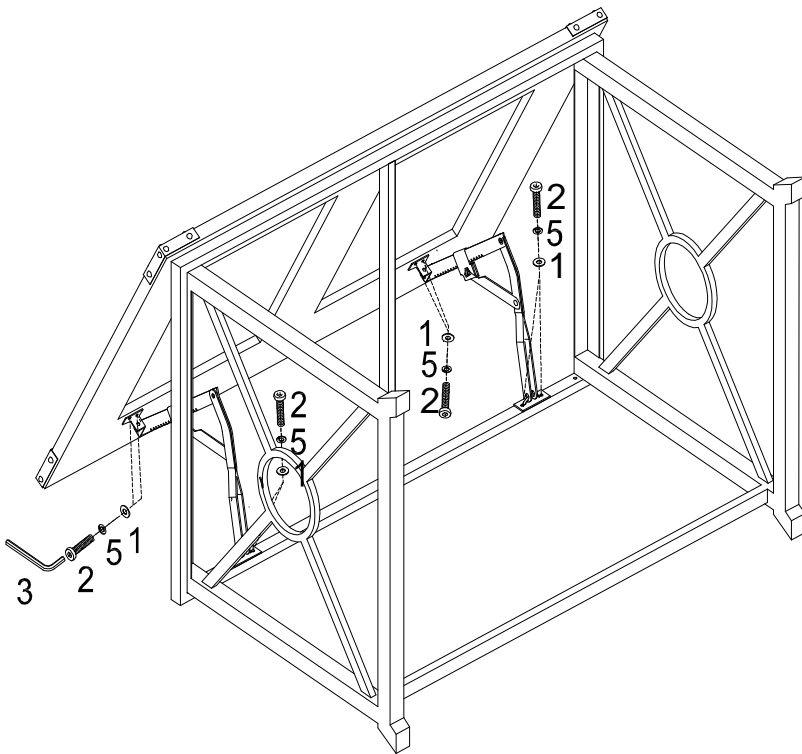
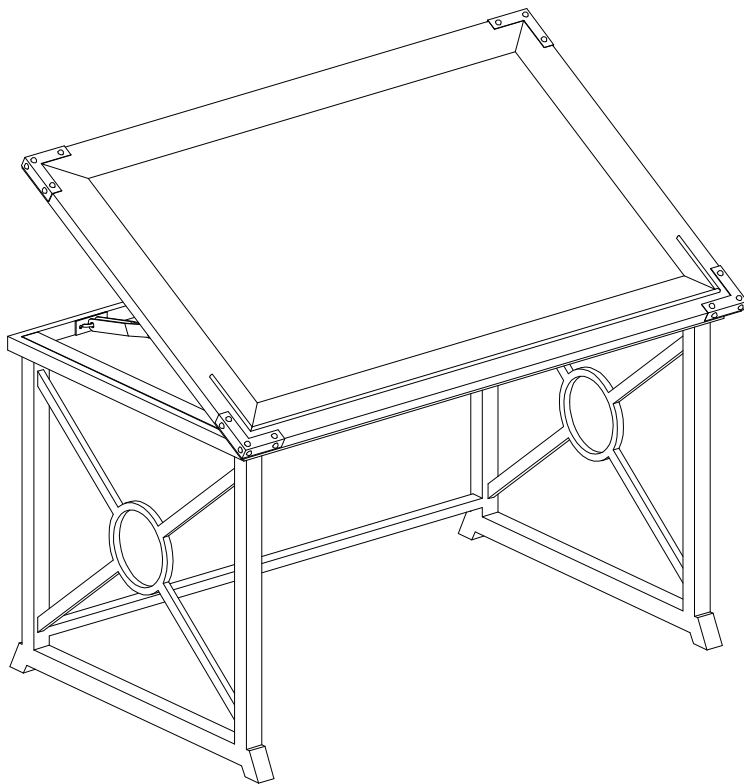
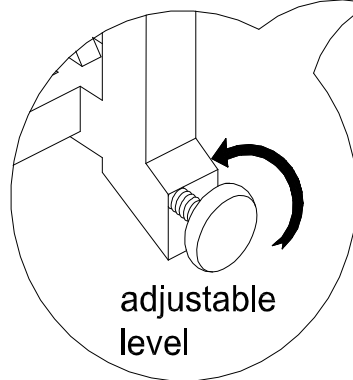
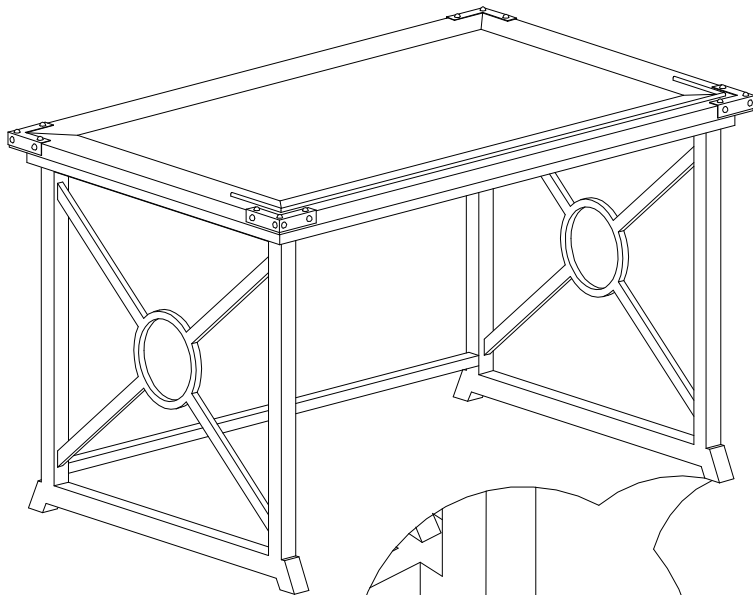

Figure 4

Lay the assembled unit down on its back as show.

Insert bolts (2) through spring washers (5) and flat washers (1) to connect Anti-Slip Hinge (4) to assembled unit from figure 3 as shown.

Tighten bolts (2) with Allen wrench (3).



Stand the table up.

Now your new tilt-top drafting table is ready to use.

If the table isn't steady, please adjust the adjustable foot level.

Important notice:

Don't hurt fingers when opening and closing the desktop. Top panel can drop when it raised to the top.

Figure 5

Parts Replacement Form

Customer Information

Name _____

Address _____

City/State/Zip Code _____

Phone Number _____

Please indicate where you purchased this item: Store/Website/Catalog

Please indicate color/size/style number:

Style No	Parts Letter	Parts Description	Quantity Needed
_____	_____	_____	_____
_____	_____	_____	_____
_____	_____	_____	_____

Please immediately examine this product carefully. Any request for missing parts or damage replacement must be received within 90 days of your receipt of the product. Replacement, if available, will be honored within this time frame. Parts will not be available for items arriving fully assembled. We do not recommend modifying product(s) and we are not responsible for any damages due to product modification(s). If damages or missing parts are not reported within 90 days of your receipt, we are under no obligation to provide parts or replacement merchandise.

Please contact Southern Enterprises at 800-633-5096 or in Dallas 972-869-0111/ 9am – 4pm Mon-Fri Central time if you have product issues or email us at service@seidal.com. Please ask for customer service representative for issues involving damages or replacement parts. Please ask for technical assistance representative for any issues with product and assembly/construction.

Please contact the retailer that you purchased from for returns.



Southern
ENTERPRISES

Page 6

Customer Service 1-800-633-5096
service@seidal.com
Southern Enterprises, Inc.
600 Freeport Parkway, Suite 200
Coppell, Texas 75019