

HZ492200TX
AG-PAPER STORAGE BIN
Assembly Instructions



Southern
ENTERPRISES

For assistance with assembly, contact :

Southern Enterprises Inc.
Customer Service 1-800-633-5096

service@seidal.com



www.seidal.com







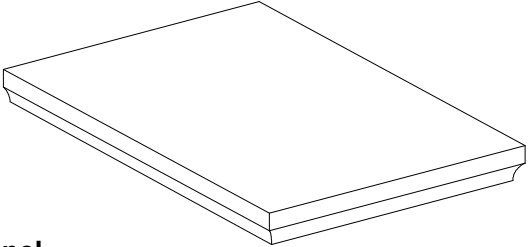
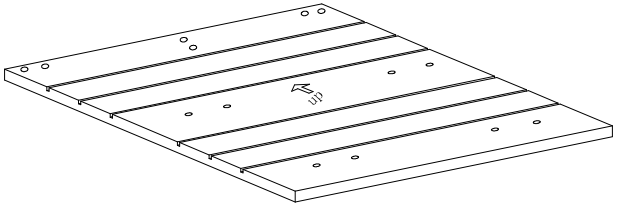
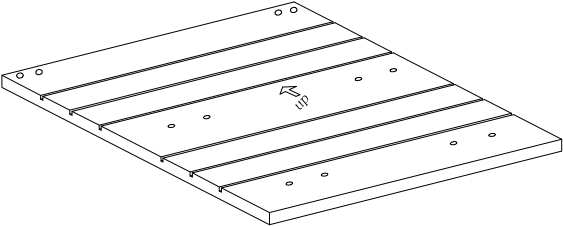
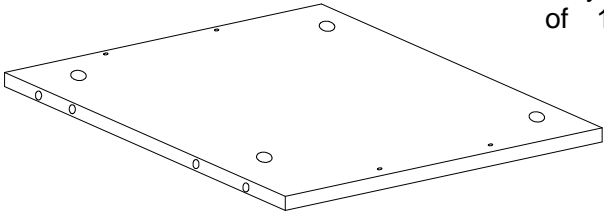
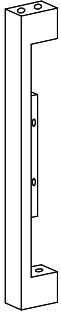
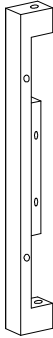
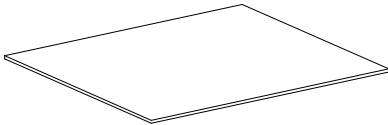
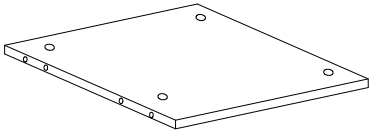

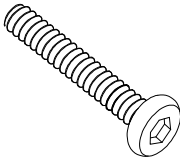
HZ492200TX AG-PAPER STORAGE BIN

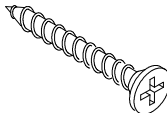
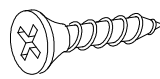
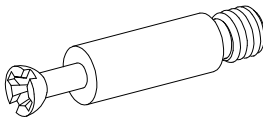
Parts List

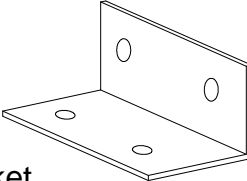
Please review all parts and hardware before disposing of any packaging.
 Call Customer Service if missing hardware.
 Using a screw that is too long will cause damage.
 Before beginning assembly, separate each type of screw. Carefully study the
 Screw diagrams below. You may receive extra hardware with your unit.

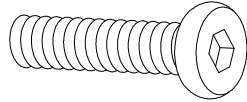
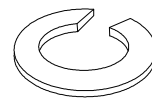
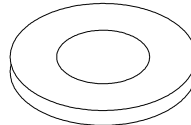
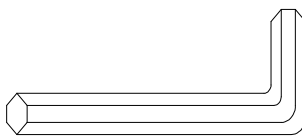
<p>A</p>  <p>Top panel</p>	<p>Quantity of 1</p> <p>B</p>  <p>Side panel-left</p> <p>Quantity of 1</p>
<p>C</p>  <p>Side panel-right</p> <p>Quantity of 1</p>	<p>D</p>  <p>Bottom panel</p> <p>Quantity of 1</p>
<p>E</p>  <p>Top rail</p> <p>Quantity of 2</p>	<p>F</p>  <p>Bottom rail</p> <p>Quantity of 2</p>
<p>G</p>  <p>Removable shelf panel</p> <p>Quantity of 6</p>	<p>H</p>  <p>Fixed shelf panel</p> <p>Quantity of 1</p>
<p>I</p>  <p>leg</p> <p>Quantity of 4</p>	<p>1 .</p>  <p>Bolt $\phi 1/4'' \times 2''$</p> <p>Quantity of 4</p>

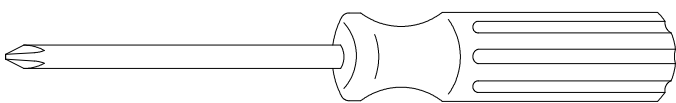
<p>2.</p>  <p>Screw M4*28mm</p>	<p>Quantity of 8</p>	<p>3.</p>  <p>Screw M4*12mm</p>	<p>Quantity of 16</p>
<p>4.</p>  <p>Cam bolt</p>	<p>Quantity of 12</p>	<p>5.</p>  <p>Cam lock</p>	<p>Quantity of 12</p>
<p>6.</p>  <p>Metal bracket</p>	<p>Quantity of 4</p>	<p>7.</p>  <p>Wood dowel $\phi 8*30\text{mm}$</p>	<p>Quantity of 20</p>
<p>8.</p>  <p>Bolt $\phi 1/4"*1-5/8"$</p>	<p>Quantity of 4</p>	<p>9.</p>  <p>Spring washer</p>	<p>Quantity of 8</p>
<p>10.</p>  <p>Flat washer</p>	<p>Quantity of 8</p>	<p>11.</p>  <p>Allen wrench</p>	<p>Quantity of 1</p>
<p>12.</p>  <p>PVC cover</p>	<p>Quantity of 2</p>		
<p>Care and Cleaning Instructions: Before using, wipe with a clean, dry cloth. Periodically apply furniture wax to renew the finish. Avoid rubbing or scratching the surface with rough or abrasive objects. For replacement parts or questions, please</p>		<p>For replacement parts or questions, please Call Customer Service at 1-800-633-5096 Do not return product to store, please call Manufacturer for assistance, questions or Parts.</p>	
<p>Assembly Tool Required No.2 Phillips Screwdriver (Not Included)</p>			

HZ492200TX

AG-PAPER STORAGE BIN

Assembly Instructions

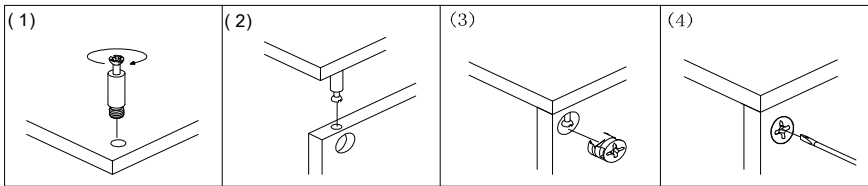

"Please do not over tighten cam bolts. Please stop when you feel tight"

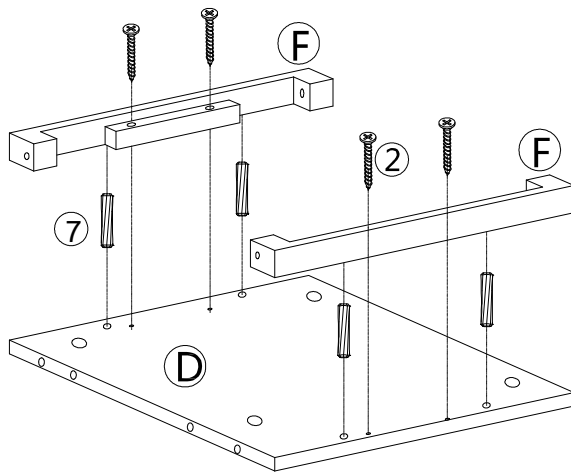

Figure 1

Unpack and lay parts on clean, padded surface like carpet or blanket. Check that you have all parts indicated on the front page

Insert screw (2) through pre-drill hole on cleat of bottom rail (F), Attach bottom rail (F) to bottom panel (D) by inserting wood dowel (7) & screw (2), Tighten screw (2) by rotating screw (2) with Phillips screwdriver (not included)

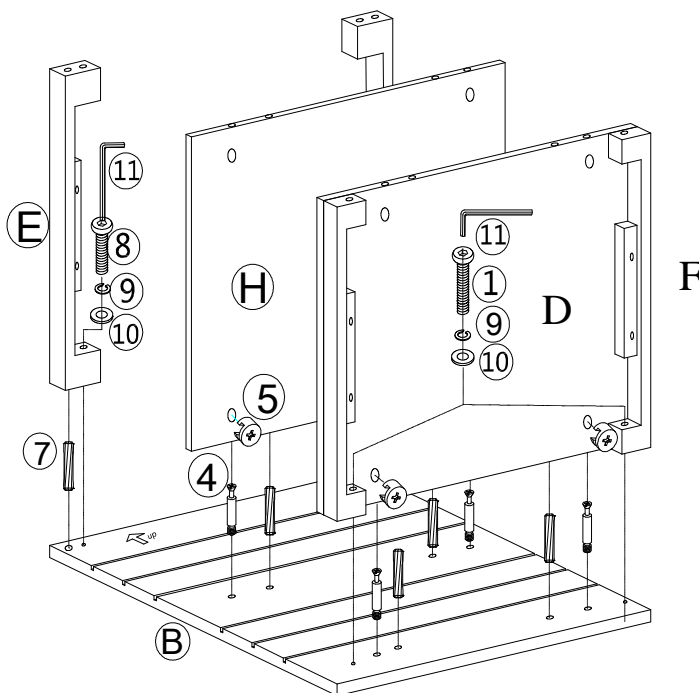

Figure 2

Insert cam locks (5) into predrilled holes on bottom shelf (D) & fixed shelf (H) Screw cam bolt (4) into pre-drilled holes on side panel-left (B) . Attach bottom panel (D) & fixed panel (H) to side panel-left (B) by inserting wood dowel (7) & cam bolt (4) into corresponding pre-drilled holes until bottom panel (D) & fixed shelf (H) & side panel-left (B) meet. Secure by rotating cam lock (5) clockwise with Phillips screwdriver (not included)

Attach top rail (E) to side panel-left (B) by using bolt (8) & spring washer (9) & flat washer (10) & wood dowel (7). Attach bottom rail (F) to side panel-left (B) using bolt (1) & spring washer (9) & flat washer (10) & wood dowel (7). Tighten bolt (1) with Allen wrench (11).

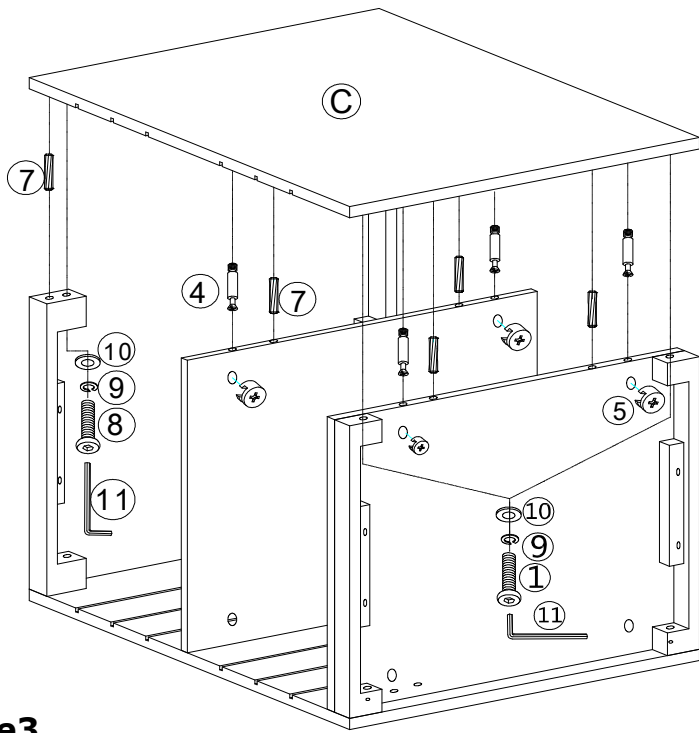

Figure3

Repeat with side panel-right(C), assemble step to be same as with figure 2

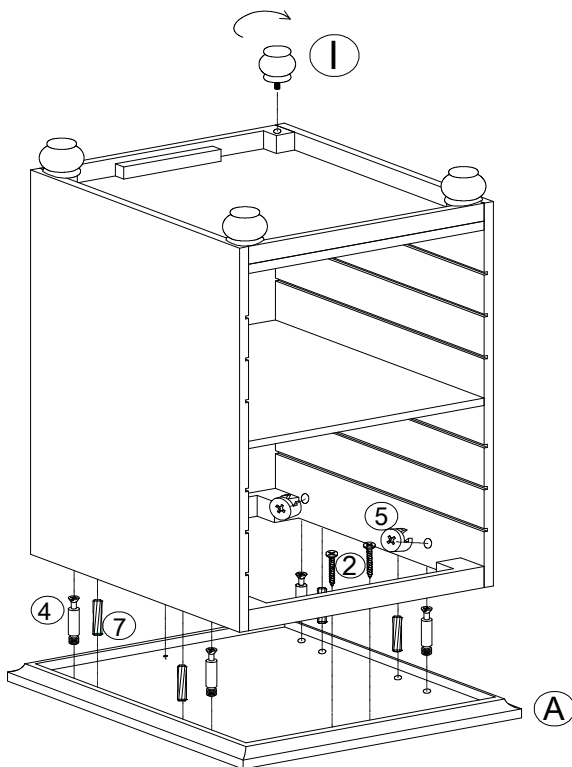

Figure4

Insert cam locks (5) into predrilled holes on preassembly unit on figure(3).
 Screw cam bolt (4) into pre-drilled holes on top panel (A) .
 Attach preassembly unit on figure (3) to top panel (A) by inserting wood dowel (7) & cam bolt (4) into corresponding pre-drilled holes until preassembly unit on figure (3) & top panel (A) meet.
 Secure by rotating cam lock (5) clockwise with Phillips screwdriver(not included)
 Insert screw(2) through predrill holes on cleat of top rail (E) to tighten preassembly unit on figure (3) unit to top panel (A) by rotating screw (2) with Philips screwdriver(not included)
 Assemble the leg (1) to pre-assembled unit on figure (3) by rotating leg (1) as shown.

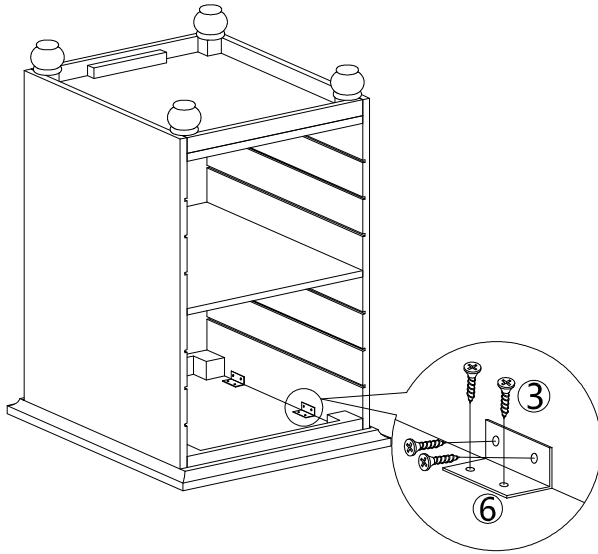

Figure5

Use metal bracket (6) and screw (3) to connect side panel-left (B) & side panel-right (C) to top panel (A). tighten screw by using Philips screwdriver (not included).

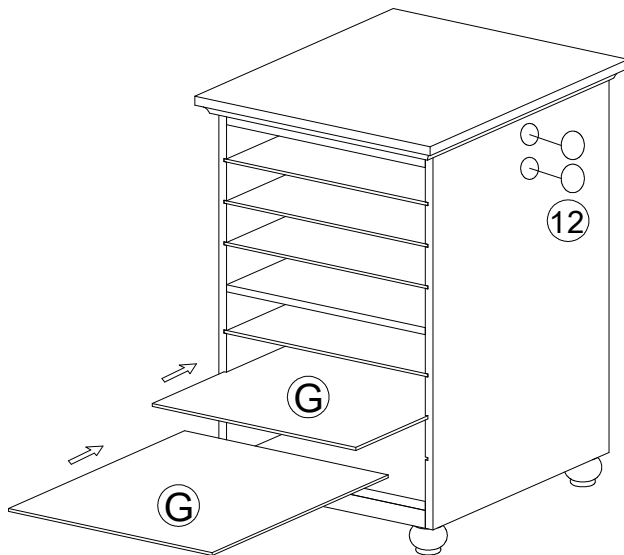

Figure6

Insert removable shelf (G) into cabinet as shown.

If you use AG-PAPER STORAGE BIN as a single unit, please cover the hole on side panel with PVC cover (12).



Figure7

Now you AG-PAPER STORAGE BIN is ready to use

Parts Replacement Form

Customer Information

Name _____

Address _____

City/State/Zip Code _____

Phone Number _____

Please indicate where you purchased this item: Store/Website/Catalog

Please indicate color/size/style number:

Style No	Parts Letter	Parts Description	Quantity Needed
----------	--------------	-------------------	-----------------

Please immediately examine this product carefully. Any request for missing parts or damage replacement must be received within 90 days of your receipt of the product. Replacement, if available, will be honored within this time frame. Parts will not be available for items arriving fully assembled. We do not recommend modifying product(s) and we are not responsible for any damages due to product modification(s). If damages or missing parts are not reported within 90 days of your receipt, we are under no obligation to provide parts or replacement merchandise. Please contact Southern Enterprises at 800-633-5096 or in Dallas 972-869-0111/ 9am – 4pm Mon-Fri Central time if you have product issues or email us at service@seidal.com. Please ask for customer service representative for issues involving damages or replacement parts. Please ask for technical assistance representative for any issues with product and assembly/construction.

Please contact the retailer that you purchased from for returns.



Southern
ENTERPRISES

Customer Service 1-800-633-5096
service@seidal.com
Southern Enterprises, Inc.
600 Freeport Parkway, Suite 200
Coppell, Texas 75019