

OC915600TX - Silver  
OC926700TX - Bronze  
OC936700TX - Blue  
OC946700TX - Purple

## Mirage Colored Mirror Cabinet

### Assembly Instructions



**Southern**  
ENTERPRISES

For assistance with assembly, contact:  
Southern Enterprises Inc.  
Customer Service: 1-800-633-5096  
[service@seidal.com](mailto:service@seidal.com)  
[www.seidal.com](http://www.seidal.com)

PO#:13599

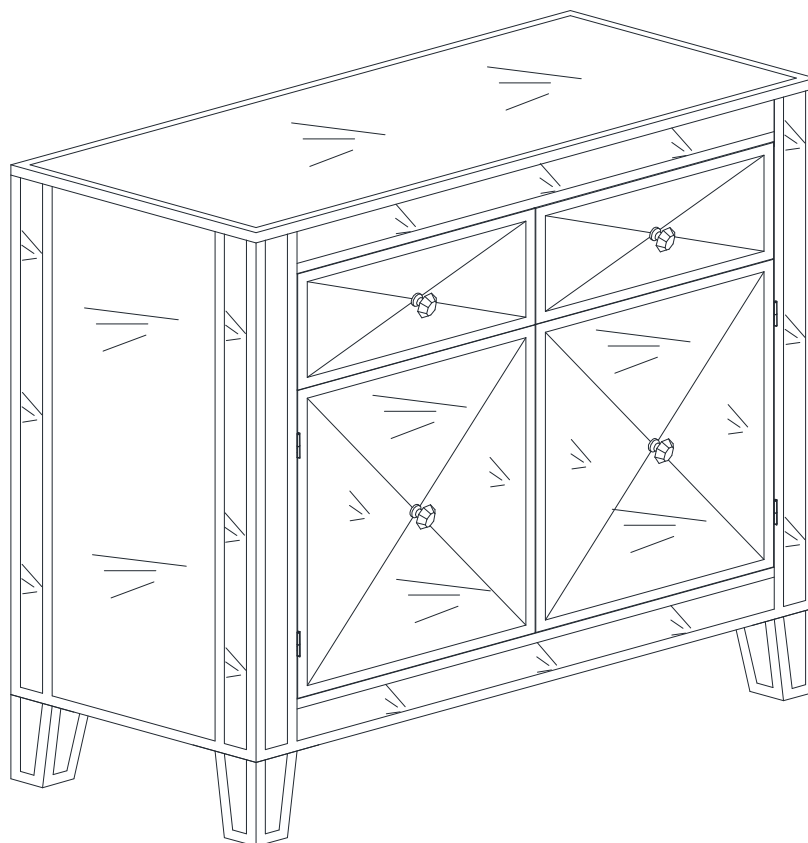

# Mirage Colored Mirror Cabinet

## Parts List

Please review all parts and hardware before disposing of any packaging. Before beginning assembly, separate each type of hardware. Carefully study the diagrams below and check that you have all parts indicated. Call Customer Service if missing hardware. Using the incorrect hardware will cause damage.

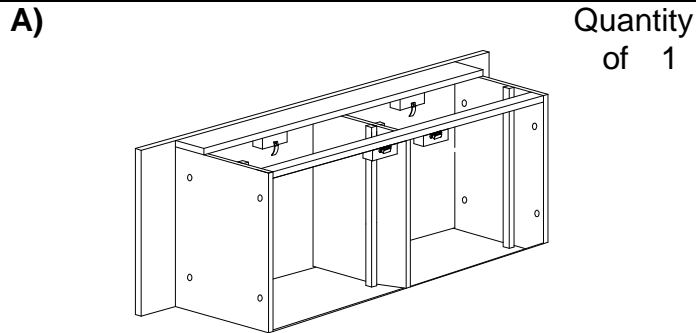

Top Frame

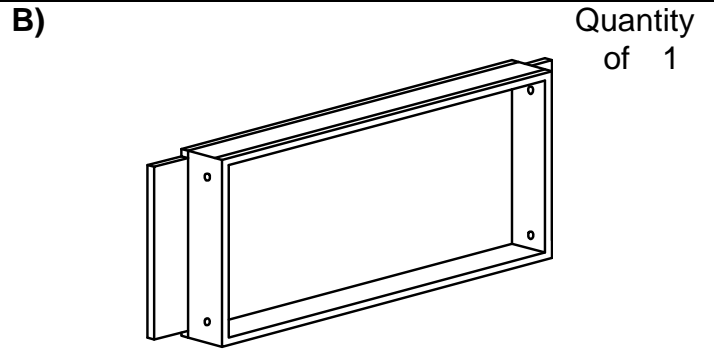

Bottom Frame

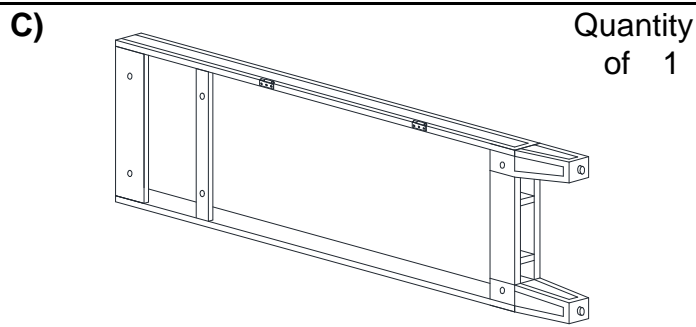

Right Frame

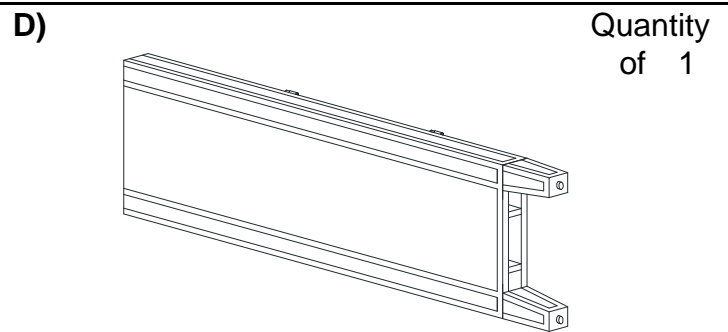

Left Frame

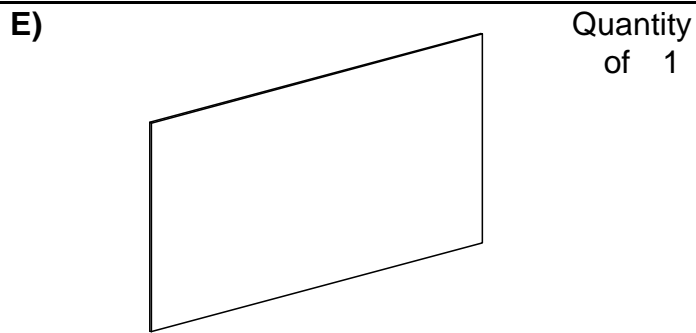

Back Panel

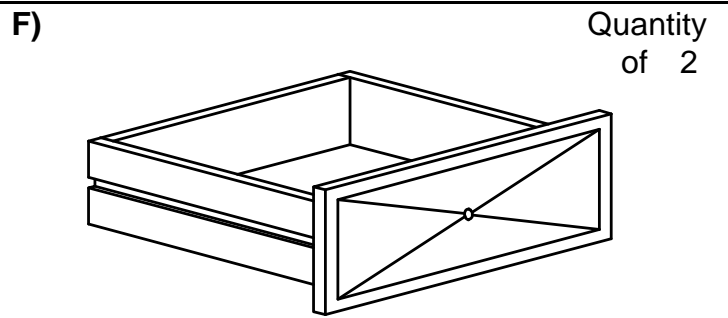

Drawers

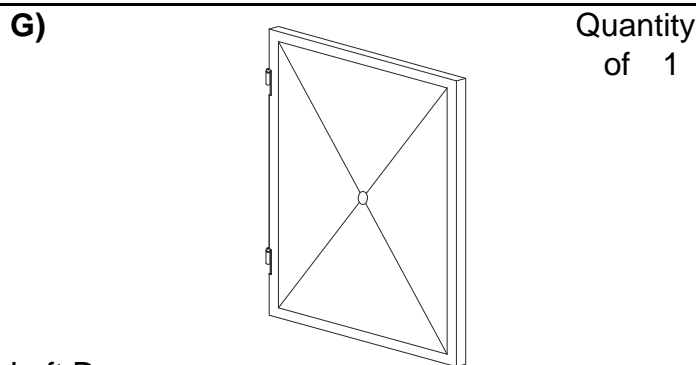

Left Door

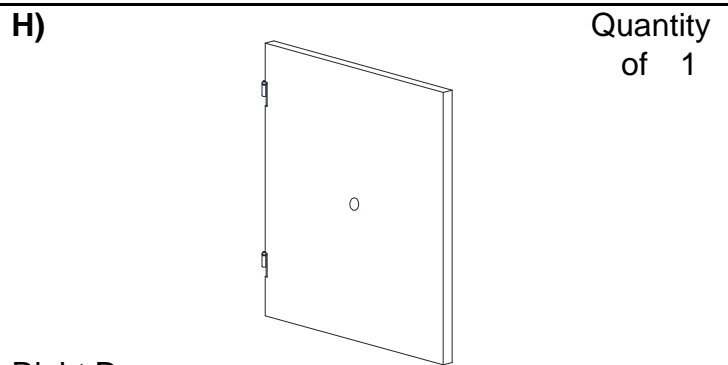





Right Door

# Mirage Colored Mirror Cabinet

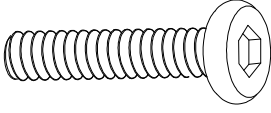
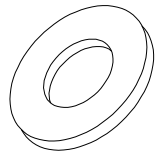
## Parts List

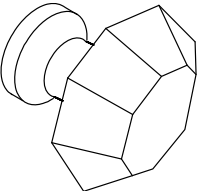
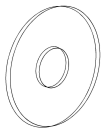
Please review all parts and hardware before disposing of any packaging. Before beginning assembly, separate each type of hardware. Carefully study the diagrams below and check that you have all parts indicated. Call Customer Service if missing hardware. Using the incorrect hardware will cause damage.

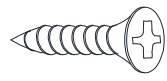
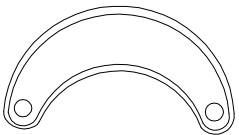
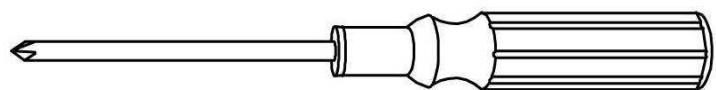
<p><b>1)</b>  Quantity of 12</p> <p>Bolts (Dia 1/4"x1-1/8"L)</p>	<p><b>2)</b>  Quantity of 12</p> <p>Flat Washers</p>
<p><b>3)</b>  Quantity of 1</p> <p>Allen Wrench</p>	<p><b>4)</b>  Quantity of 2</p> <p>Short Bolts (Dia 5/32"x3/4"L)</p>
<p><b>5)</b>  Quantity of 4</p> <p>Knobs</p>	<p><b>6)</b>  Quantity of 4</p> <p>Plastic Washers</p>
<p><b>7)</b>  Quantity of 2</p> <p>Long Bolts (Dia 5/32"x1"L)</p>	<p><b>8)</b>  Quantity of 12</p> <p>Wood Screws (Dia 2.5mmx10mmL)</p>
<p><b>9)</b>  Quantity of 6</p> <p>Plastic Catches</p>	
<p><b>Care and Cleaning Instructions:</b> Before using, wipe with a clean, dry cloth. Avoid rubbing or scratching the surface with rough or abrasive objects.</p>	<p>For replacement parts or questions, please call customer service at 1-800-633-5096.</p>
<p><b>Assembly Tool Required:</b> No.2 Phillips Screwdriver (Not Included)</p>	

# Mirage Colored Mirror Cabinet

## Assembly Instructions

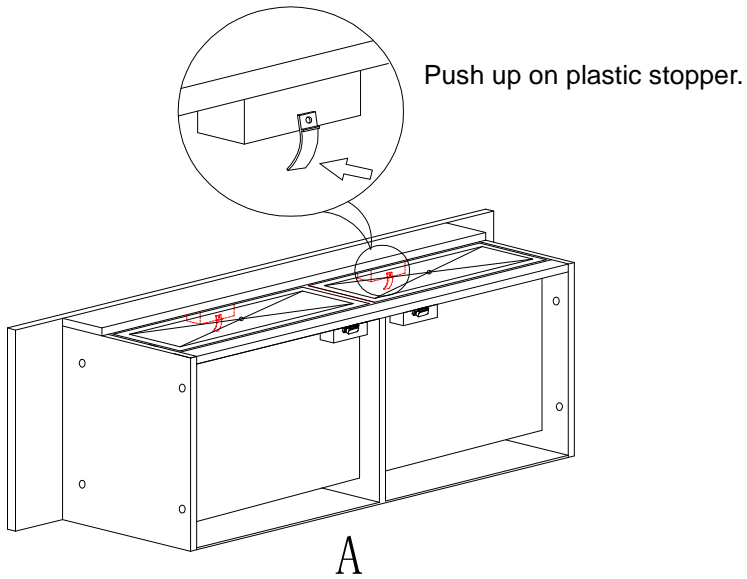

**Start assembly with drawers removed.** Push white stopper by hand, then remove drawers.

Attach Right Frame (C) to Top Frame (A) and Bottom Frame (B) with Bolts (1) and Flat Washers (2).

Tighten bolts with Allen Wrench (3).

**Don't fully tighten bolts until Step 2 is complete.**

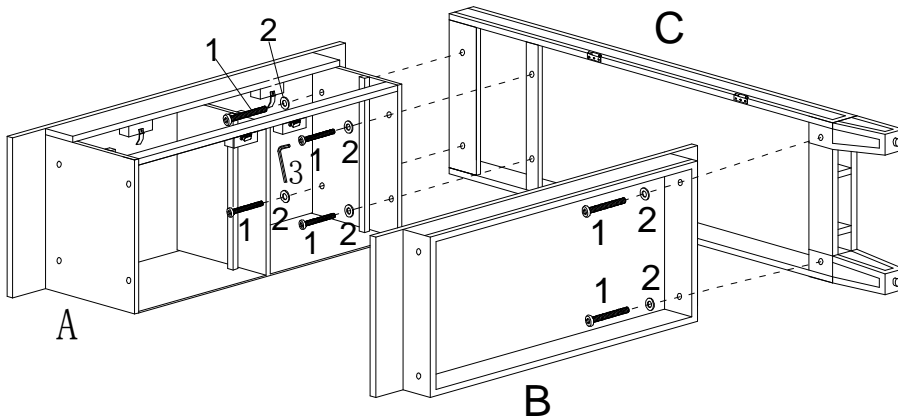
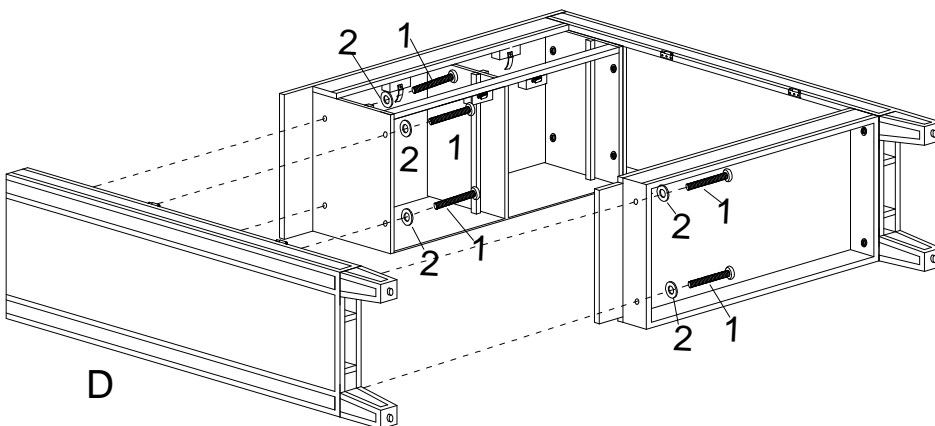

Figure 1



Attach Left Frame (D) to Top Frame (A) and Bottom Frame (B) with Bolts (1) and Flat Washers (2).

Tighten bolts with Allen Wrench (3).

**Fully tighten all bolts. Be careful not to tighten too much as it may cause damage.**

Figure 2

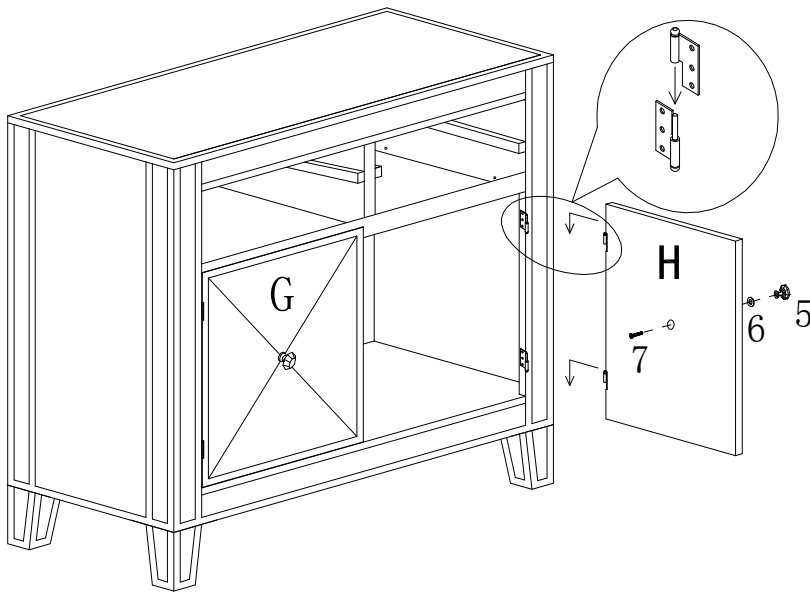

**Figure 3**

Attach Left Door **(G)** and Right Door **(H)** by aligning pre-installed male hinges on side panels with pre-installed female hinges on doors.

Attach Knobs **(5)** and Plastic Washers **(6)** to door with Long Bolts **(7)**.

Tighten bolts with screwdriver.

**Caution: Please do not over tighten knobs. Stop when they start to feel tight.**

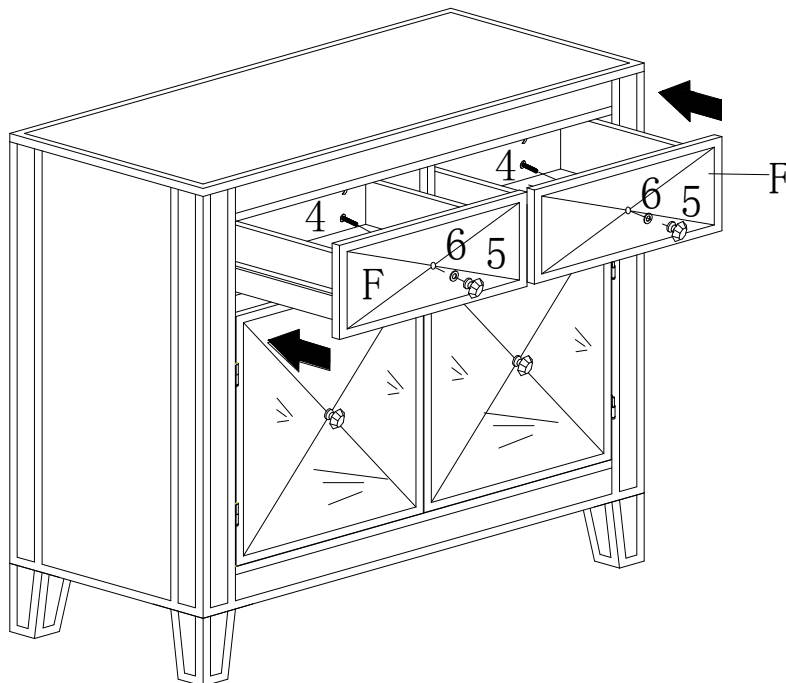

**Figure 4**

Insert drawers back into unit.

Attach Knobs **(5)** and Plastic Washers **(6)** to drawers with Short Bolts **(4)**.

Tighten bolts with screwdriver.

**Caution: Please do not over tighten knobs. Stop when they start to feel tight.**

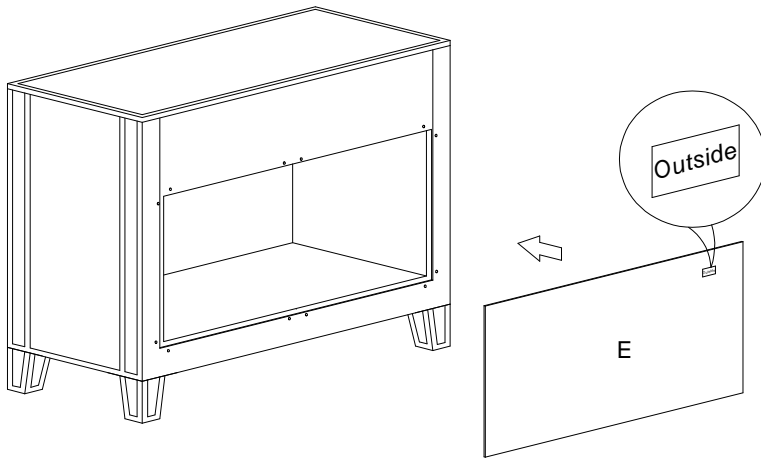

Place Back Panel **(E)** into opening in back of unit.

Attach Plastic Catch **(9)** to Back Panel **(E)** with Wood Screws **(8)**.

Tighten screws with screwdriver.

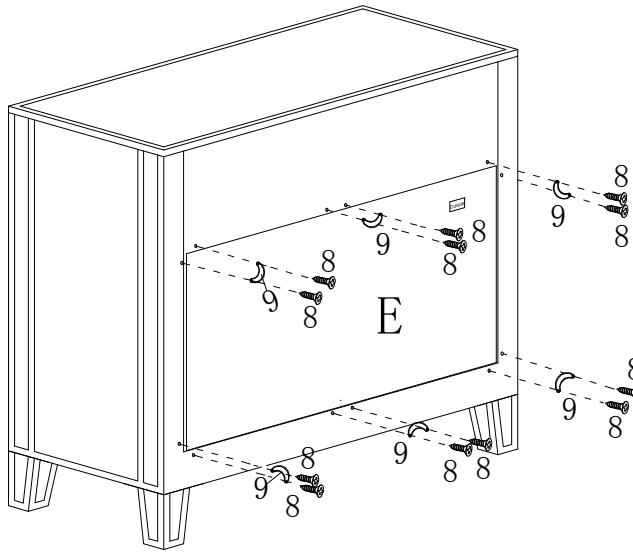

**Figure 5**

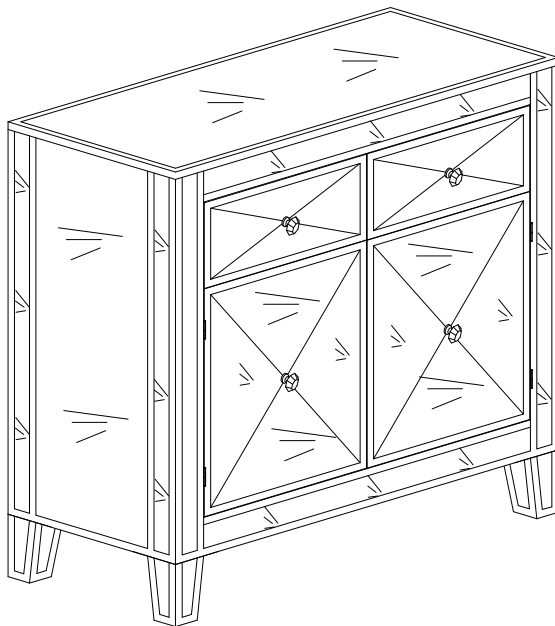

Now your new Mirage Colored Mirror Cabinet is ready to use!

**Figure 6**

# Parts Replacement Form

## Customer Information

Name \_\_\_\_\_

Address \_\_\_\_\_

City/State/Zip Code \_\_\_\_\_

Phone Number \_\_\_\_\_

Please indicate where you purchased this item: Store/Website/Catalog

\_\_\_\_\_

Please indicate color/size/style number:

\_\_\_\_\_

Style No	Parts Letter	Parts Description	Quantity Needed
_____	_____	_____	_____
_____	_____	_____	_____
_____	_____	_____	_____

Please immediately examine this product carefully. Any request for missing parts or damage replacement must be received within 90 days of your receipt of the product. Replacement, if available, will be honored within this time frame. Parts will not be available for items arriving fully assembled. We do not recommend modifying product(s) and we are not responsible for any damages due to product modification(s). If damages or missing parts are not reported within 90 days of your receipt, we are under no obligation to provide parts or replacement merchandise.

For product issues, please contact Southern Enterprises at 800-633-5096 (toll-free) / 972-869-0111 (Dallas), Mon-Fri 9am – 4pm CST, or email us at [service@seidal.com](mailto:service@seidal.com). Please ask for customer service representative for issues involving damages or replacement parts. Please ask for technical assistance representative for any issues with product and assembly/construction.

Please contact the retailer that you purchased from for returns.



**Southern**  
ENTERPRISES

Customer Service: 1-800-633-5096

[service@seidal.com](mailto:service@seidal.com)

Southern Enterprises, Inc.  
600 Freeport Parkway, Suite 200  
Coppell, Texas 75019