



assembly instructions
consignes d'assemblage
instrucciones de ensamblaje

English

Nexera makes every effort to ensure the highest level of quality control at every point of production. Rarely a negligible defect may occur or a part maybe missing from the package. If a defect does appear after complete assembly or a part is missing, please call our toll free Customer SERVICE LINE. You don't need to return the unit to the store.

Français

En vue de vous assurer des pièces de première qualité, Nexera garantit un contrôle rigoureux de la qualité à chaque étape de production. Si toutefois une défectuosité a échappé à notre attention et que cette imperfection demeure apparrente après l'assemblage ou qu'une pièce se trouve manquante, téléphonez-nous au numéro sans frais.

Español

Teniendo por objetivo asegurarle al cliente un producto de primera calidad, la Cia Nexera lleva acabo un riguroso control de calidad en cada etapa de la producción. Sin embargo, si algún defecto hubiese escapado de nuestra atención y afecta la apariencia de su mueble, o si le faltase alguna pieza, sirvase comunicarse con nosotros sin gasto alguno. Estimado cliente, ud no necesita devolver este producto al comerciante.

Nexera Distribution



CANADA / USA
Fax

1-877-629-9022
1-450-629-4366



monday to friday
9H AM - 5H PM

lundi au vendredi
9h à 17h



E-Mail / Courriel

service@nexeradistribution.com



Webpage / Page web

www.nexeradistribution.com

produit no. product no. producto no.

221803

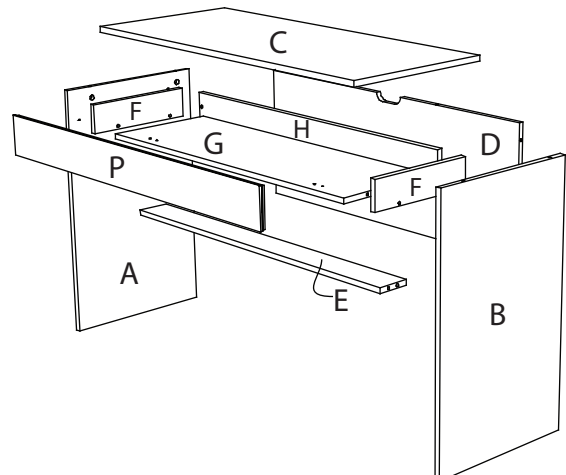
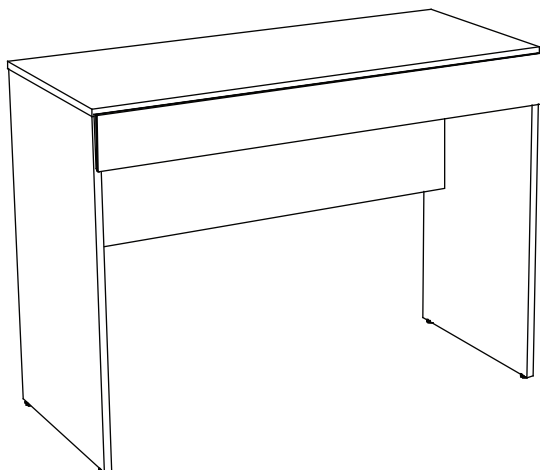

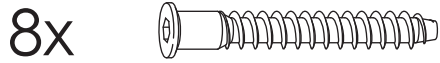

20-0111

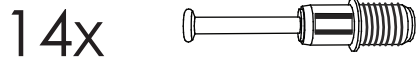

20-2200



20-0203

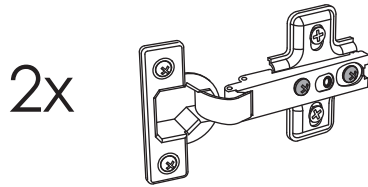

20-0401



20-0527



20-0509

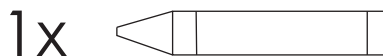

20-2135

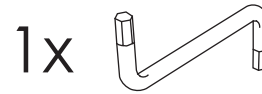

20-2300

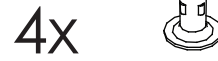

20-2150



20-1111



20-0120

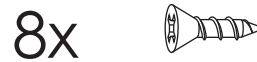

20-0105



20-0110



201515

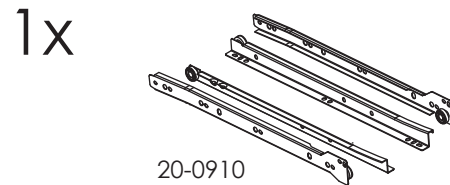

20-0910

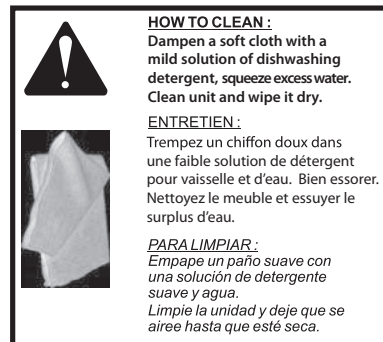
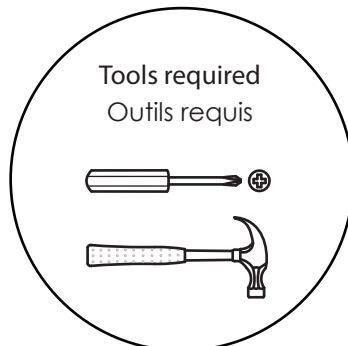

01

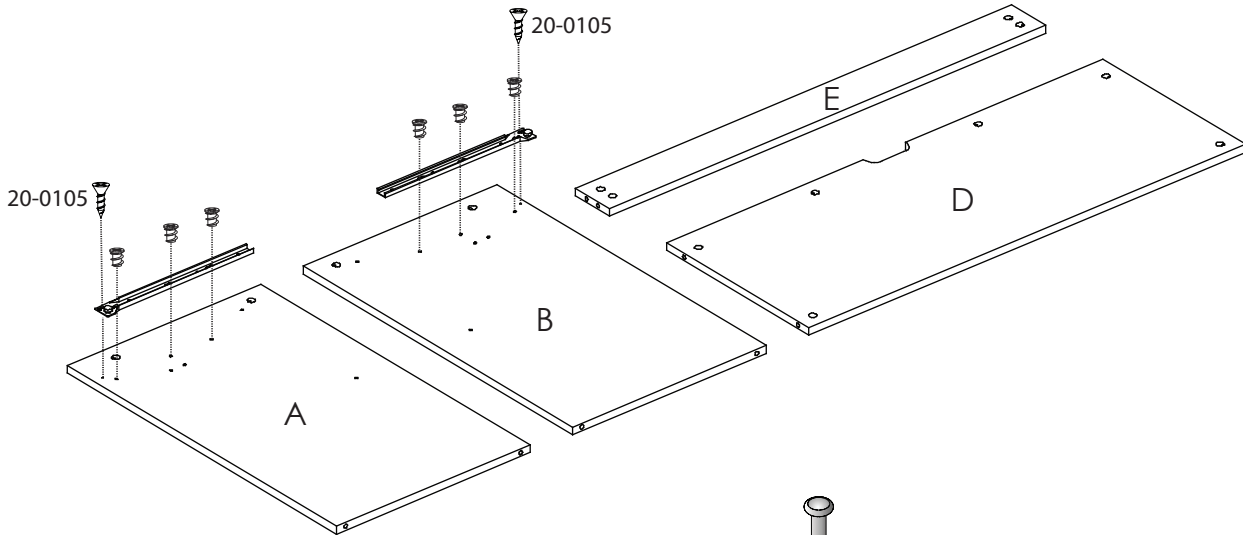
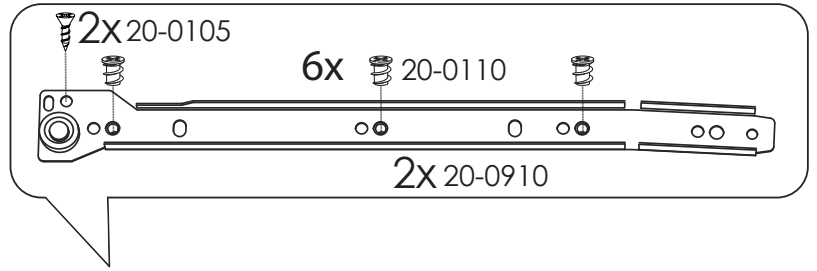
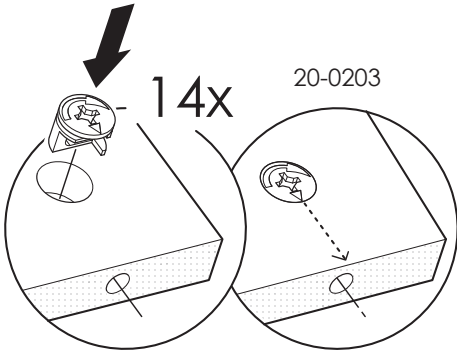

02

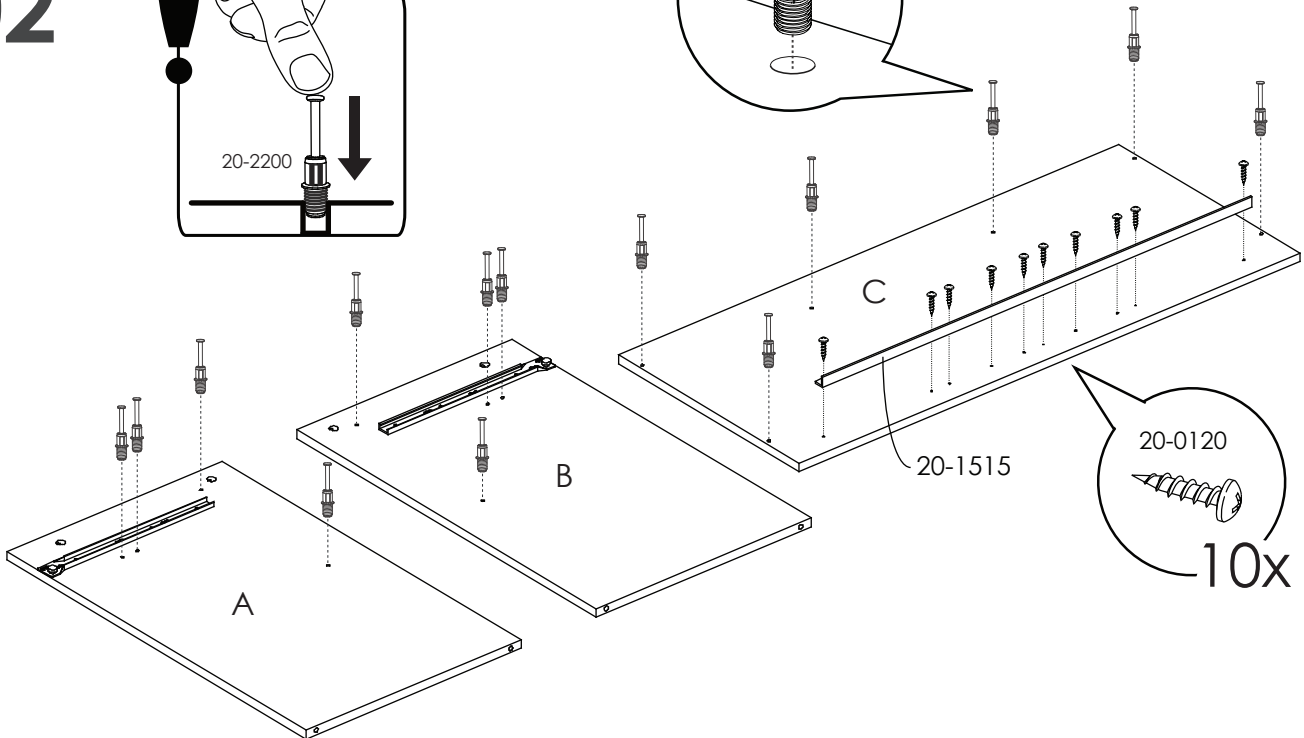
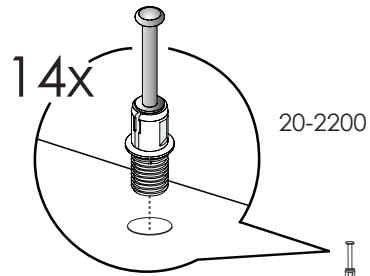
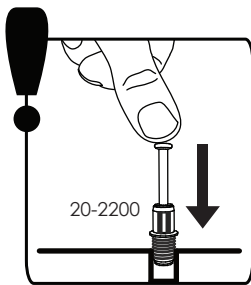

03

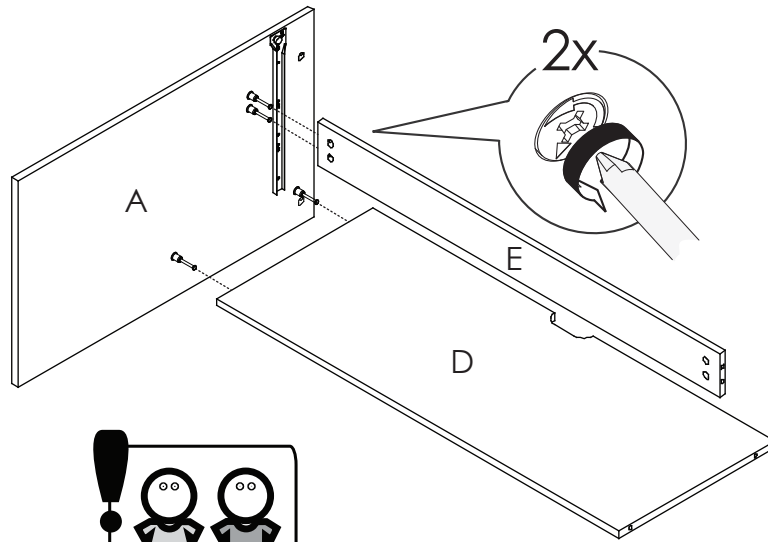
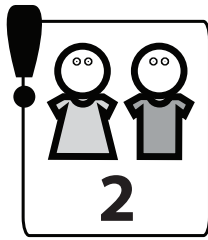

04

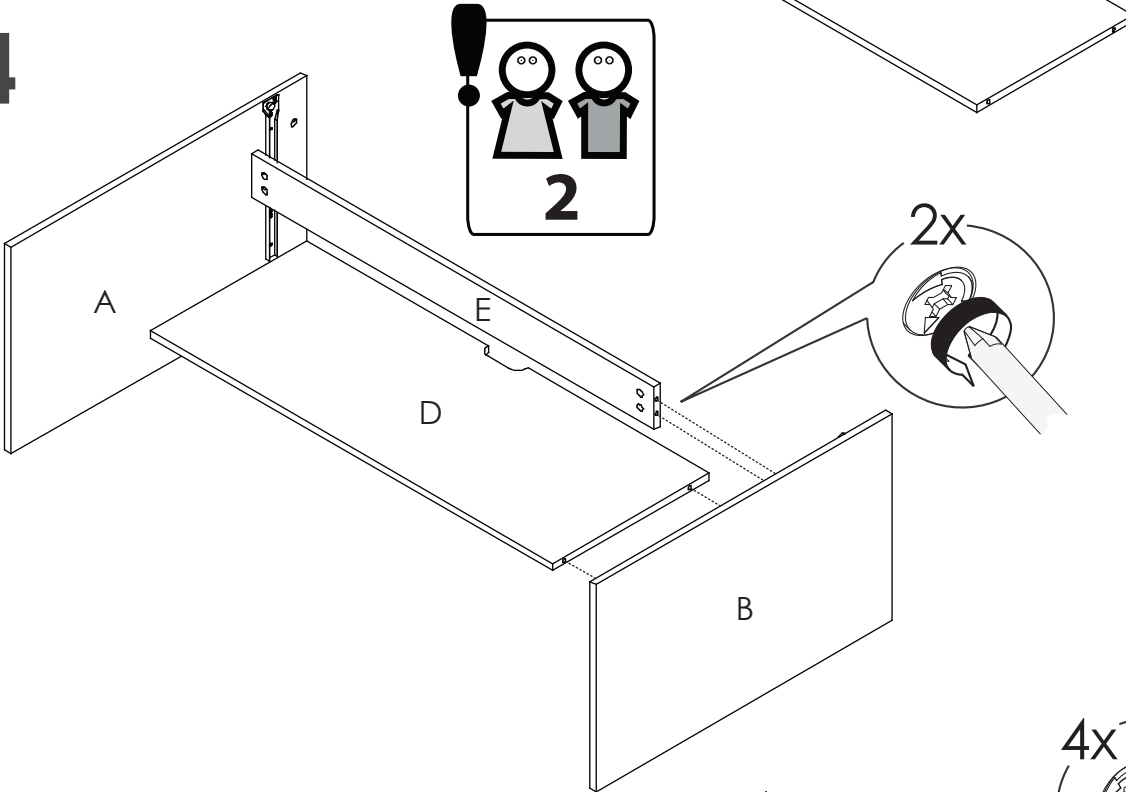
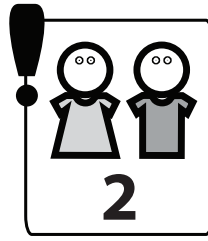

05

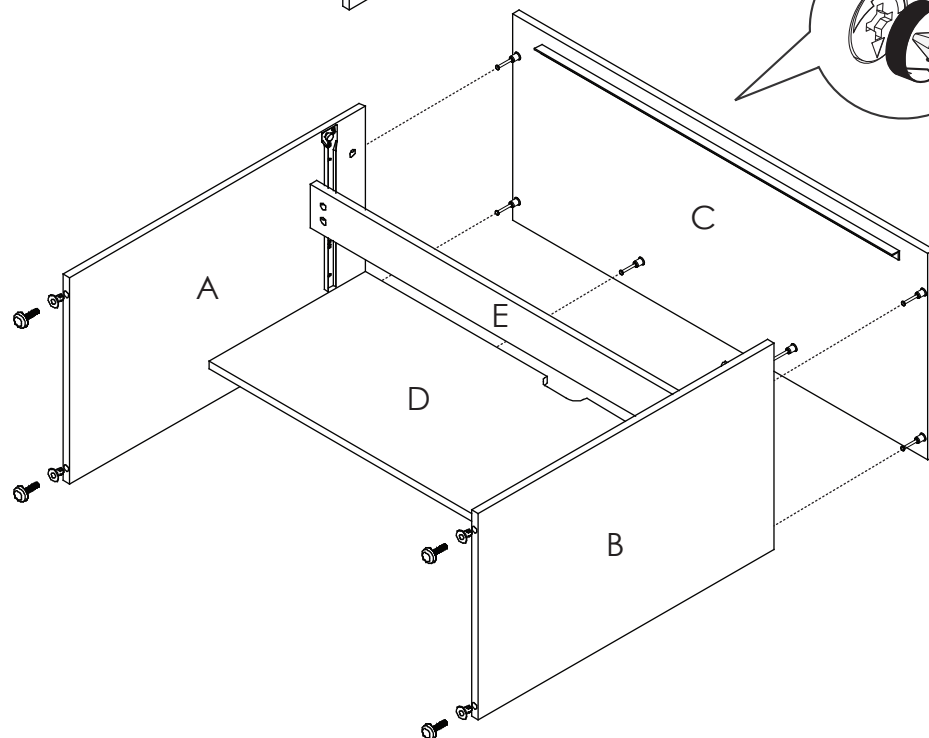
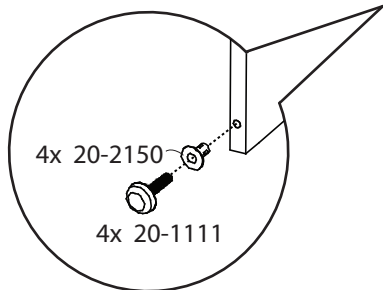
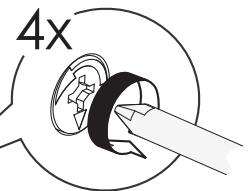

06

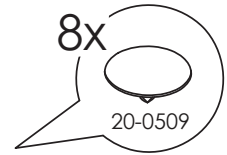
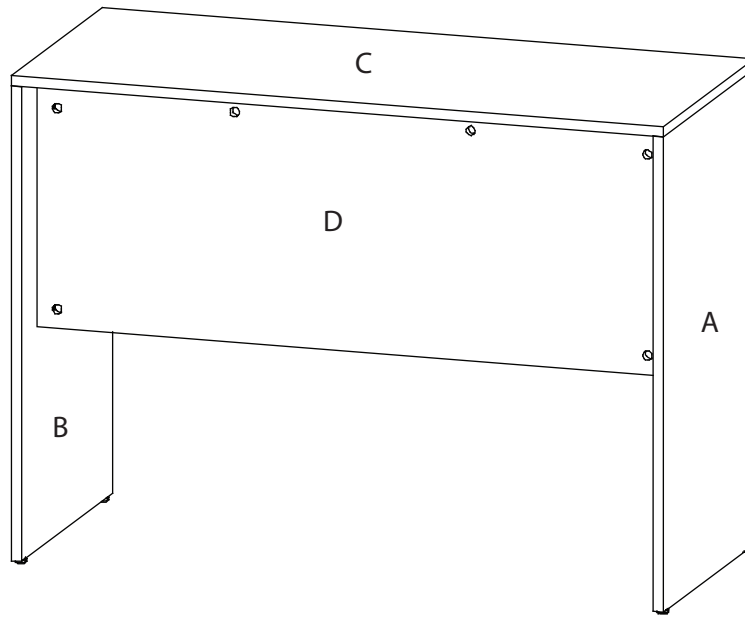
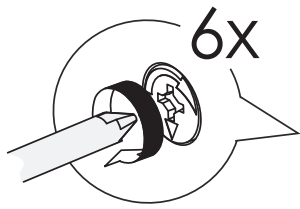

07

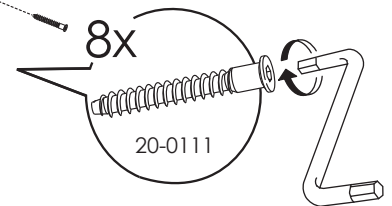
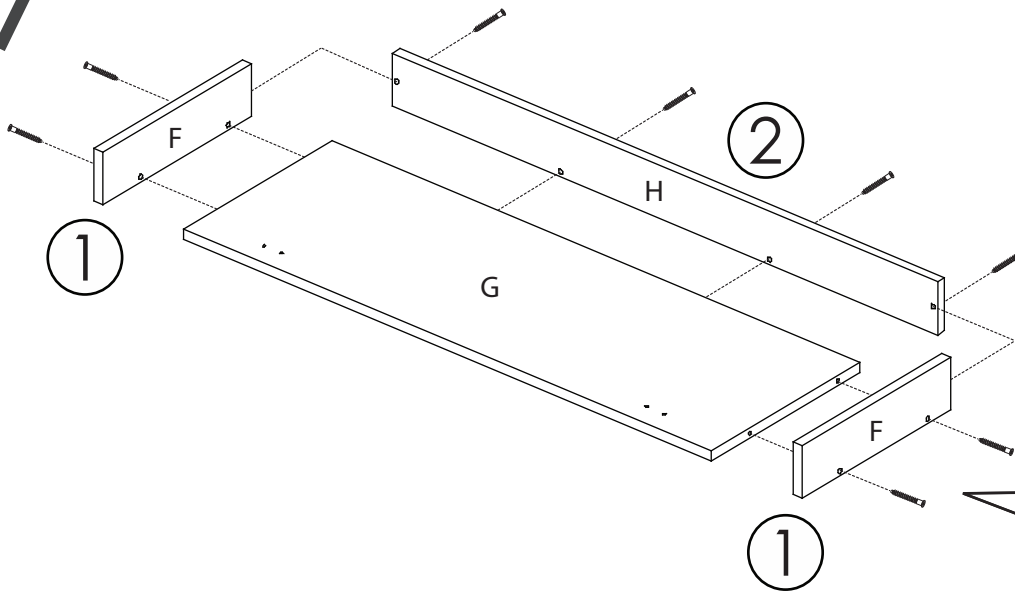

08

Align slide with front edge
Alignez la coulisse avec le chant avant

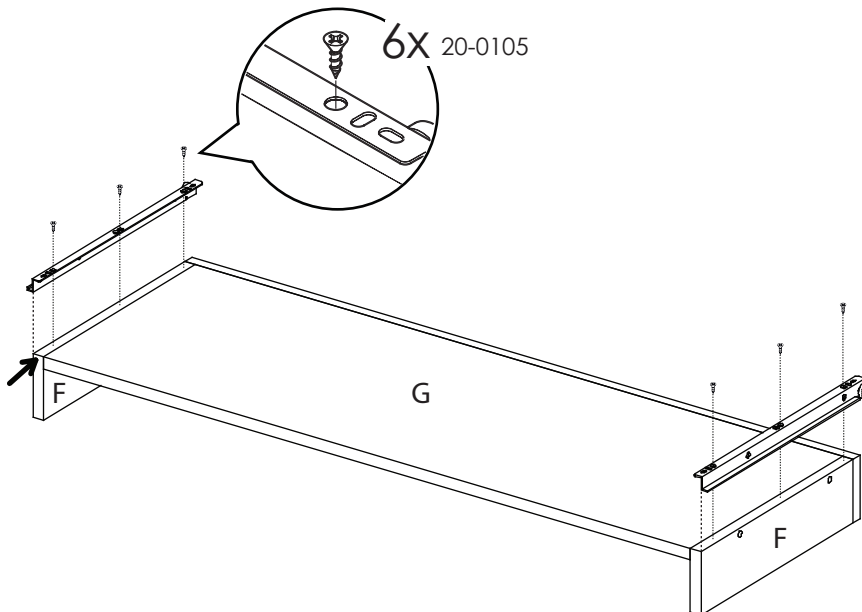

09

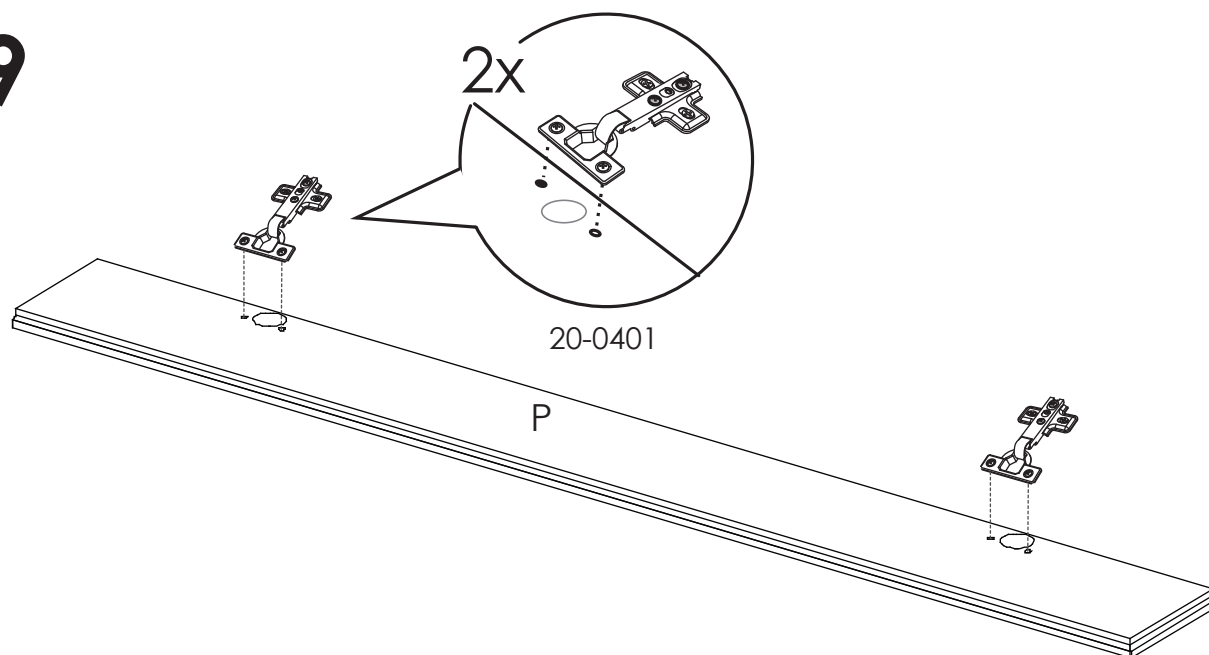

10

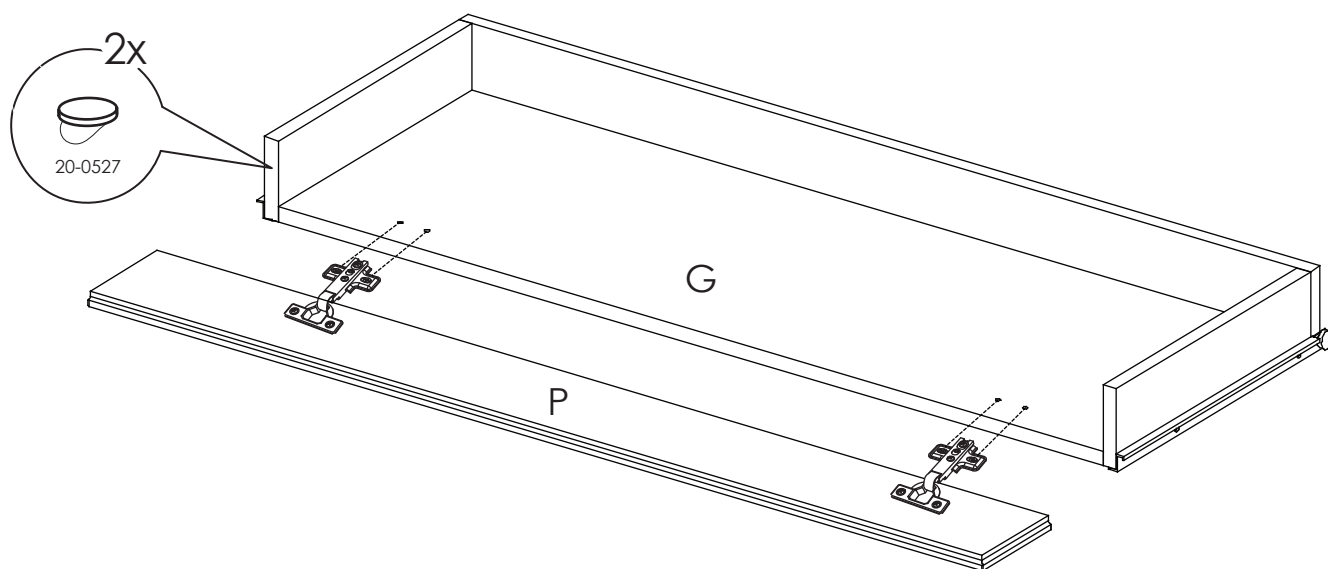

11

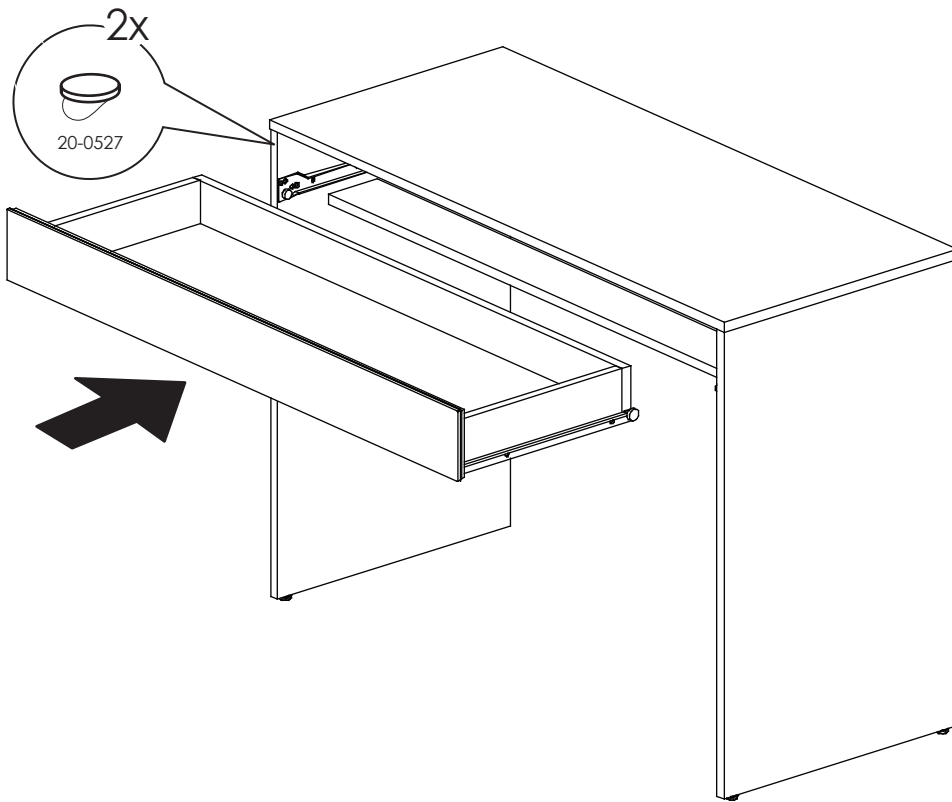

12

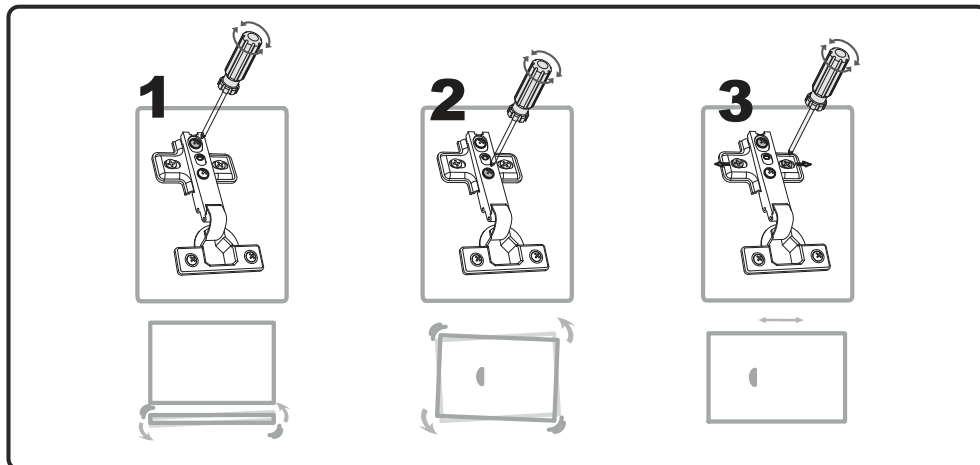

Limited 1 Year Warranty

All Nexera products are warranted to the original purchaser against defects in material or workmanship for a period of 1 year from the date of purchase.

"Defects" as used in this warranty is defined as any imperfections that may impair the use of the furniture or product for which it was intended to.

This warranty is expressly limited to the replacement of defective furniture parts and/or components, subject to availability of stock. Assembly labor is excluded.

This warranty applies under conditions of normal use. It does not cover defects caused by improper assembly or disassembly, product modification, intentional damage, abuse, misuse, accidents, negligence or exposure to the elements. Our furniture products are not intended for outdoor use.

This warranty is only applicable in Canada and the USA.

Nexera reserves the right to request proof of purchase from an authorized retailer as well as any other proofs to document a warranty claim.

This warranty is explicit on the limits of Nexera liability and entitles the original purchaser to specific rights. Any warranty defined by law in your state/province is limited to 1 year. Should the law in your state or province differ from the above, it will not apply.

Garantie limitée de 1 an

Tous les produits Nexera sont garantis à l'acheteur original contre toutes défectuosités de matériel ou de fabrication pour une période de 1 an à partir de la date d'achat.

Le mot "défectuosités" utilisé dans cette garantie signifie toutes imperfections pouvant nuire à l'utilisation du meuble ou du produit pour lequel il a été conçu.

Cette garantie est expressément limitée au remplacement des pièces ou composantes défectueuses, sujet à la disponibilité des stocks. La main d'œuvre de l'assemblage est exclue.

Cette garantie s'applique dans des conditions d'utilisation normales. Elle ne couvre pas des défectuosités résultant d'un assemblage ou désassemblage défaillant, modification du produit, dommages intentionnels, abus, usage impropre, accidents, négligence ou des expositions aux éléments extérieurs. Nos meubles ne sont pas destinés pour une utilisation à l'extérieur.

Cette garantie s'applique uniquement au Canada et aux États-Unis.

Nexera se réserve le droit d'exiger une preuve d'achat ou toutes autres pièces justificatives pour valider cette garantie.

Cette garantie est limitative quant à la responsabilité de Nexera et donne à l'acheteur original des droits spécifiques. Toute garantie législative prévalant dans votre lieu de résidence est limitée à une période de 1 an. Advenant le cas que la législation de votre lieu de résidence diffère de celle-ci, elle ne s'applique s'appliquera pas.

Garantía limitada de 1 año

Nexera garantiza todos sus productos contra defectos en materiales y mano de obra por un periodo de 1 año a partir de la fecha original de la compra.

Para efectos de esta garantía, "defecto" significa toda imperfección que puede perjudicar el uso del mueble o el producto para el que fue concebido.

Esta garantía se limita expresamente al reemplazo de las partes defectuosas o sus componentes, según las disponibilidades. No incluye la mano de obra del ensamblaje.

Esta garantía se aplica en condiciones de uso normal. No cubre los defectos causados por ensamblaje o desensamblaje inapropiados, modificación del producto, daño intencional, abuso, mal uso, accidente, negligencia o exposición a elementos exteriores. Nuestros productos no deben usarse al exterior.

Esta garantía se aplica únicamente en Canadá y Estados Unidos.

Nexera se reserva el derecho de exigir pruebas de compra al vendedor autorizado o toda otra prueba para validar esta garantía.

Esta garantía es explícita en cuanto a las limitaciones de responsabilidad de Nexera y otorga al comprador original derechos específicos. Toda garantía jurídica en su provincia o estado de residencia se a 1 año. En caso de que las leyes provinciales o estatales difieran, la garantía no se aplicará.

nexera
www.nexeradistribution.com