

2-DRAWER WRITING DESK  
HO8799 ESPRESSO FINISHING  
HO8800 WHITE FINISHING  
HO8801 BLACK FINISHING  
HO8797 Agate Green FINISHING  
HO8796 Agate Gray FINISHING  
HO8795 PINK FINISHING  
Assembly Instructions



Southern  
ENTERPRISES

For assistance with assembly contact:  
Southern Enterprises Inc.  
Customer Service 1-800-633-5096  
[service@seidal.com](mailto:service@seidal.com)  
[www.seidal.com](http://www.seidal.com)

PO#:

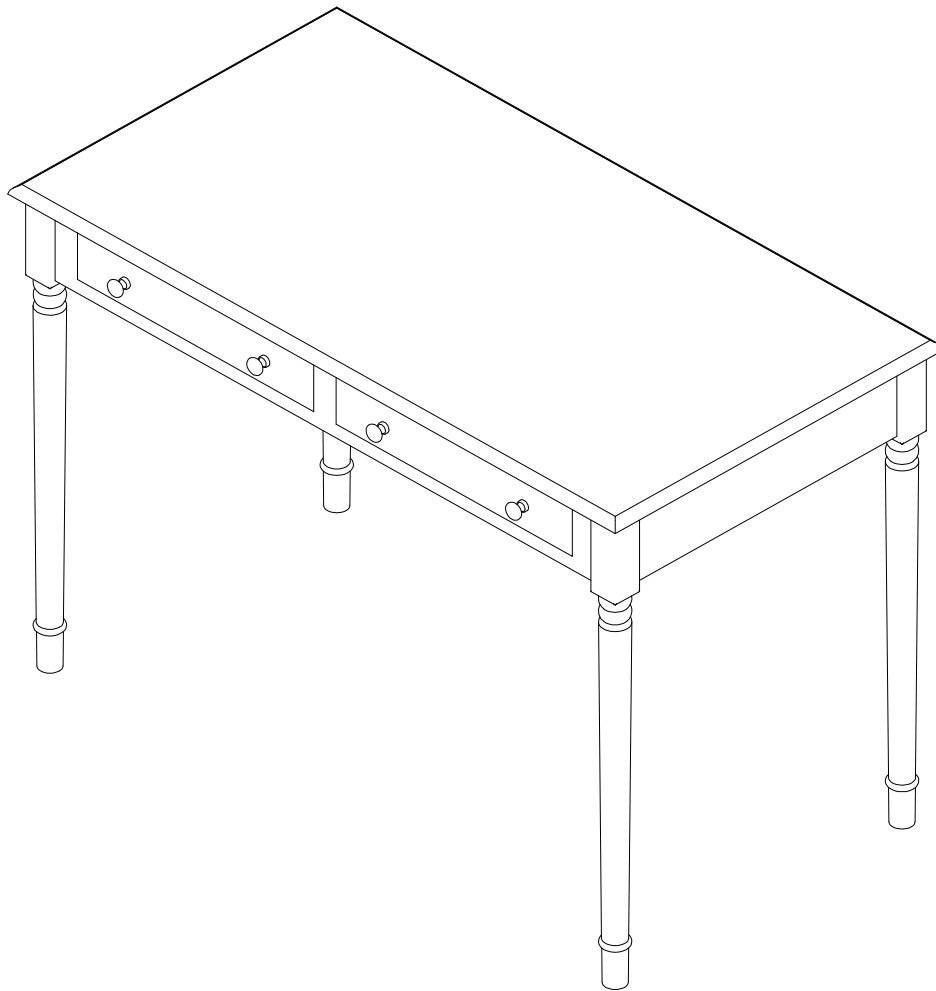

# 2-DRAWER WRITING DESK



## Parts List

Please review all parts and hardware before disposing of any packaging.

Call Customer Service if missing hardware.

Using hardware that is too long will cause damage.

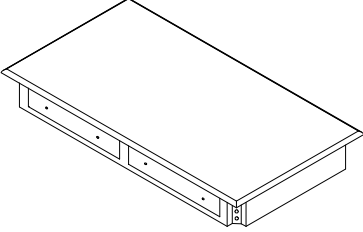
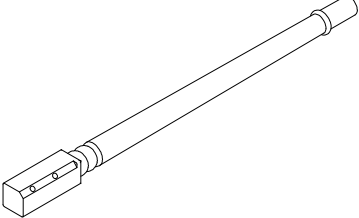
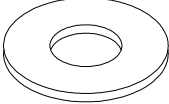
Before beginning assembly, separate each type of hardware. Carefully study the hardware diagrams below. You may receive extra hardware with your unit.

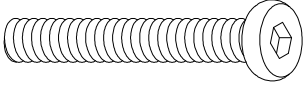
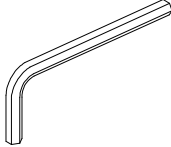
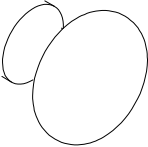
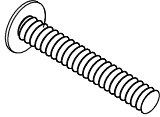
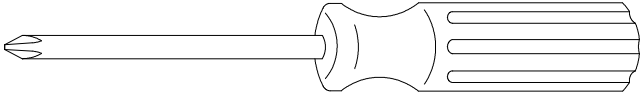
<p>1</p>  <p>Top Frame</p> <p>Quantity Of 1</p>	<p>2</p>  <p>Leg</p> <p>Quantity Of 4</p>
<p>A</p>  <p>Flat Washer</p> <p>Quantity Of 8</p>	<p>B</p>  <p>Spring Washer</p> <p>Quantity Of 8</p>
<p>C</p>  <p>Allen Bolt</p> <p>Quantity Of 8</p>	<p>D</p>  <p>Allen Key</p> <p>Quantity Of 1</p>
<p>E</p>  <p>drawer pull knob</p> <p>Quantity Of 4</p>	<p>F</p>  <p>Bolt</p> <p>Quantity Of 4</p>
<p><b>Care and Cleaning Instructions:</b> Before using, wipe with a clean, dry cloth. Periodically apply furniture wax to renew the finish. Avoid rubbing or scratching the surface with rough or abrasive objects.</p>	<p>For replacement parts or questions, please call customer service at 1-800-633-5096.</p>
<p><b>Assembly Tool Required No.2 Phillips Screwdriver (Not Included)</b></p>	

# 2-DRAWER WRITING DESK

## Assembly Instruction

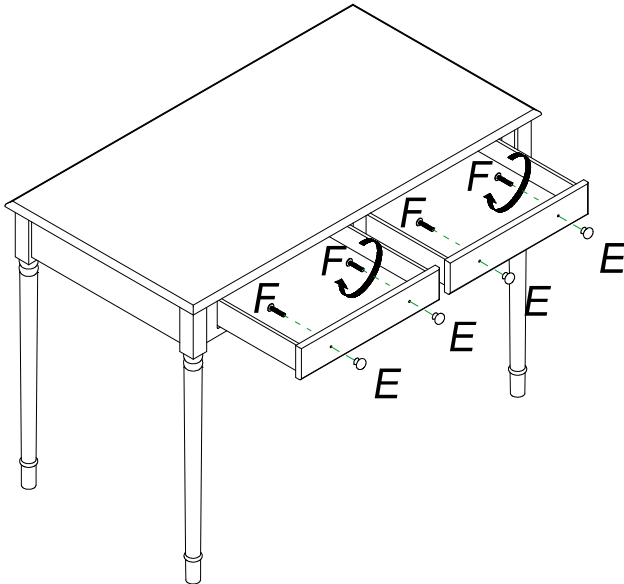
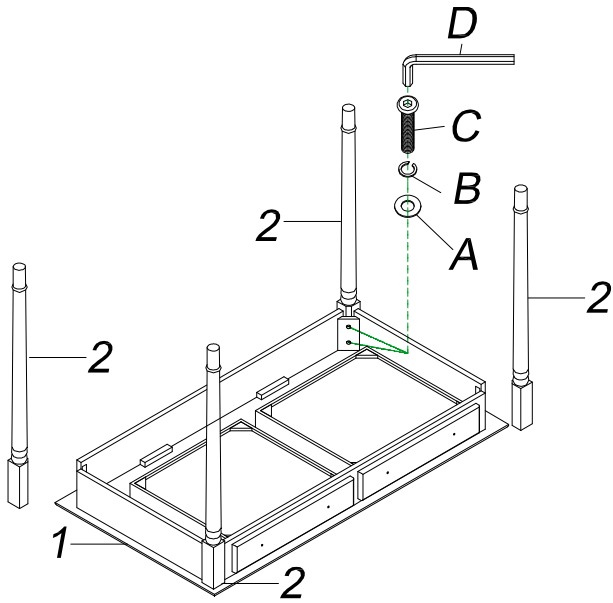

### Assembly Instructions:

Wood may scratch easily. Be careful when assembling. Do not scratch.

Step 1. Unpack and lay parts on clean, padded surface like carpet or blanket. Check that you have all parts indicated on the front page.

Step 2. Put Top Frame (1) upside down on a soft working surface.

Step 3. Put the Flat Washers (A) and Spring Washers (B) into Allen Bolts (C), attach the Legs (2) into corner block with Allen Bolts (C) by Allen Key (D).

Step 4. Fasten the Allen Bolt (B).

Step 5. Open the drawer  
Attach the drawer pull knob (E) on the drawer face using Bolt (F).

Tighten Bolt (F) with a Phillips screwdriver.

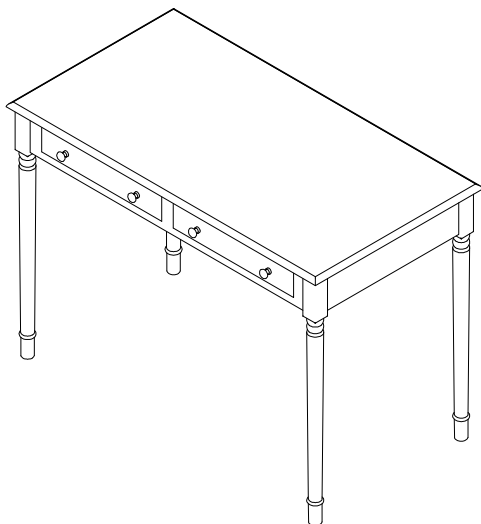

Turn the assembly right side up.

**Max loading weight:40LB**

# Parts Replacement Form

## Customer Information

Name \_\_\_\_\_

Address \_\_\_\_\_

City/State/Zip Code \_\_\_\_\_

Phone Number \_\_\_\_\_

Please indicate where you purchased this item: Store/Website/Catalog

\_\_\_\_\_

Please indicate color/size/style number:

\_\_\_\_\_

Style No	Parts Letter	Parts Description	Quantity Needed
_____	_____	_____	_____
_____	_____	_____	_____
_____	_____	_____	_____

Please immediately examine this product carefully. Any request for missing parts or damage replacement must be received within 90 days of your receipt of the product. Replacement, if available, will be honored within this time frame. Parts will not be available for items arriving fully assembled. We do not recommend mowe are not responsible for any damages due to product modification(s). If damages or missing parts are not reported within 90 days of your receipt, we are under no obligation to provide parts or replacement merchandise.

Please contact Southern Enterprises at 800-633-5096 or in Dallas 972-869-0111/ 9am – 4pm Mon-Fri Central time if you have product issues or email us at [service@seidal.com](mailto:service@seidal.com). Please ask for customer service representative for issues involving damages or replacement parts. Please ask for technical assistance representative for any issues with product and assembly/construction.

Please contact the retailer that you purchased from for returns.



Customer Service 1-800-633-5096  
[service@seidal.com](mailto:service@seidal.com)  
Southern Enterprises, Inc.  
600 Freeport Parkway, Suite 200  
Coppell, Texas 75019