

CK877200TX - Black

CK077200TX - Silver

CK277200TX - Red

CK377200TX - Gold

Metal End Table

Assembly Instructions



Southern
ENTERPRISES

For assistance with assembly, contact:
Southern Enterprises Inc.
Customer Service 1-800-633-5096
service@seidal.com
www.seidal.com

PO:

Top supports up to 25 lb.

Shelf supports up to 15 lb.

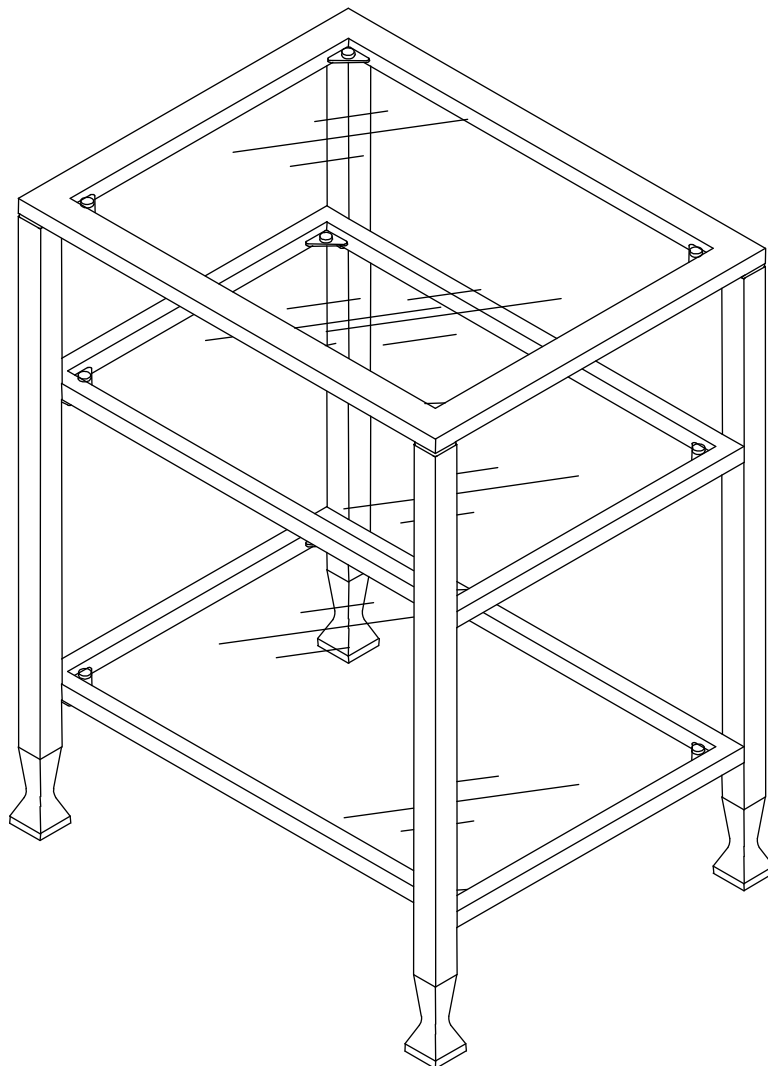

CK877200TX - Black

CK077200TX - Silver

CK277200TX - Red



CK377200TX - Gold

Metal End Table

Parts List

You may receive extra hardware with your unit.

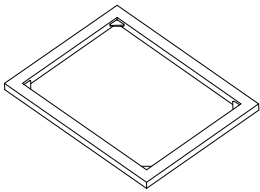
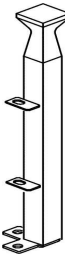
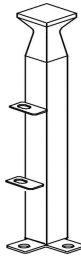
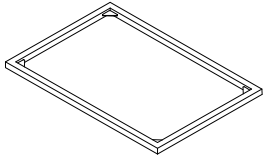
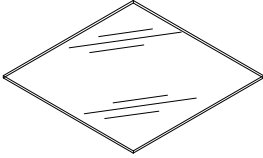
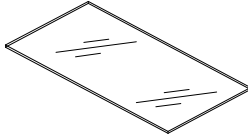
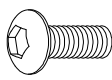
Please review all parts and hardware before disposing of any packaging.
 Call Customer Service if missing hardware. Do not return to store/retailer.
 Using a screw that is too long will cause damage. Before beginning assembly,
 separate each type of screw. Carefully study the screw diagrams below.

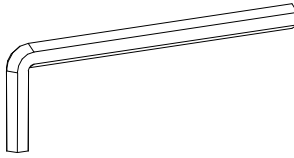
<p>1 1PC</p>  <p>Top Frame</p>	<p>2 2PCS</p>  <p>Right Leg</p>	<p>3 2PCS</p>  <p>Left Leg</p>	<p>4 2PCS</p>  <p>Shelf Frame</p>
<p>5 1PC</p>  <p>Top Glass</p>	<p>6 2PCS</p>  <p>Glass Shelf</p>	<p>A 16PCS</p>  <p>Screw 1/4"x13mm</p>	<p>B 16PCS</p>  <p>Lock Washer 1/4"</p>
<p>C 12PCS</p>  <p>Glass pad</p>	<p>D 1PC</p>  <p>Wrench</p>		

Care and Cleaning Instructions:
 Before using, wipe with a clean, dry cloth.
 Avoid rubbing or scratching the surface with
 rough or abrasive objects.

For replacement parts or questions, please
 call Customer Service at 1-800-633-5096.

CK877200TX - Black
CK077200TX - Silver
CK277200TX - Red
CK377200TX - Gold
Metal End Table
Assembly Instructions

Figure 1

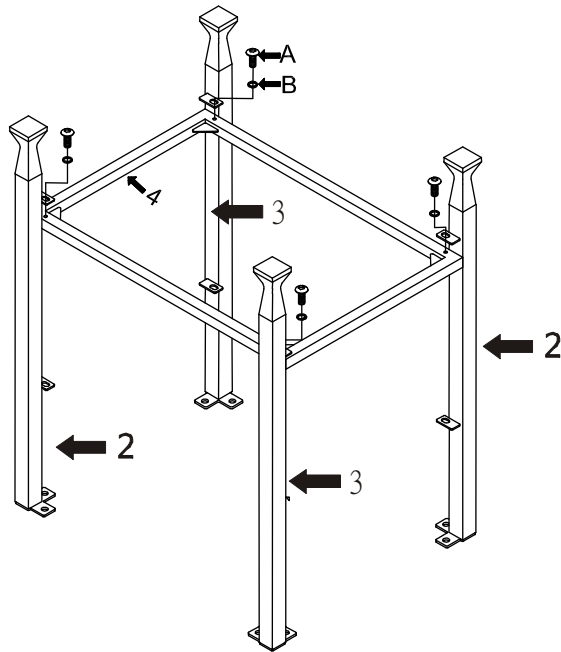

Step 1:

Using Screws **(A)** and Lock Washers **(B)**, attach Shelf Frame **(4)**, Right Legs **(2)** and Left Legs **(3)** as shown.

Figure 2

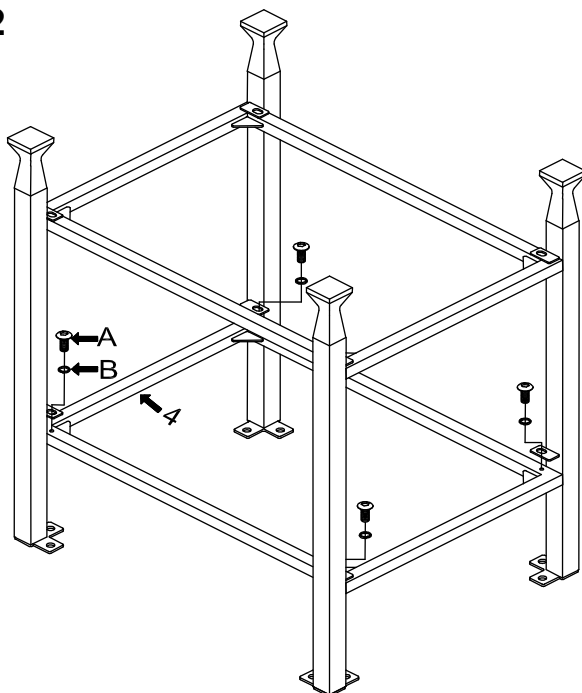

Step 2:

Using Screws **(A)** and Lock Washers **(B)**, attach Shelf Frame **(4)**, Right Leg **(2)** and Left Leg **(3)** as shown.

Figure 3

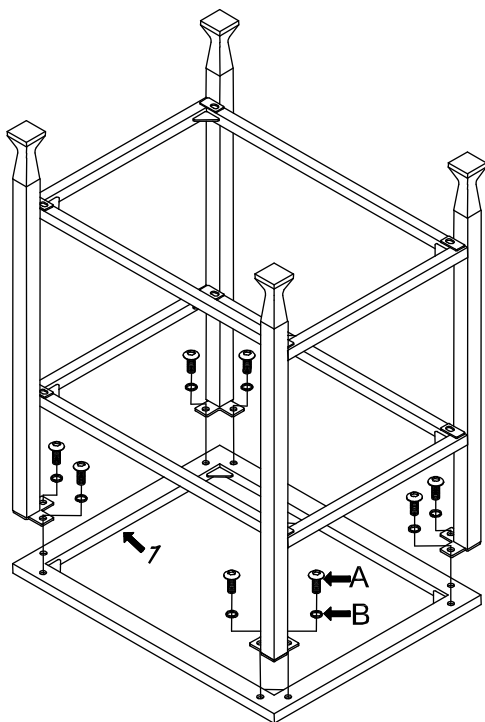

Step 3:

Using Screws **(A)** and Lock Washers **(B)**, attach Top Frame **(1)** and Legs as shown.

Figure 4

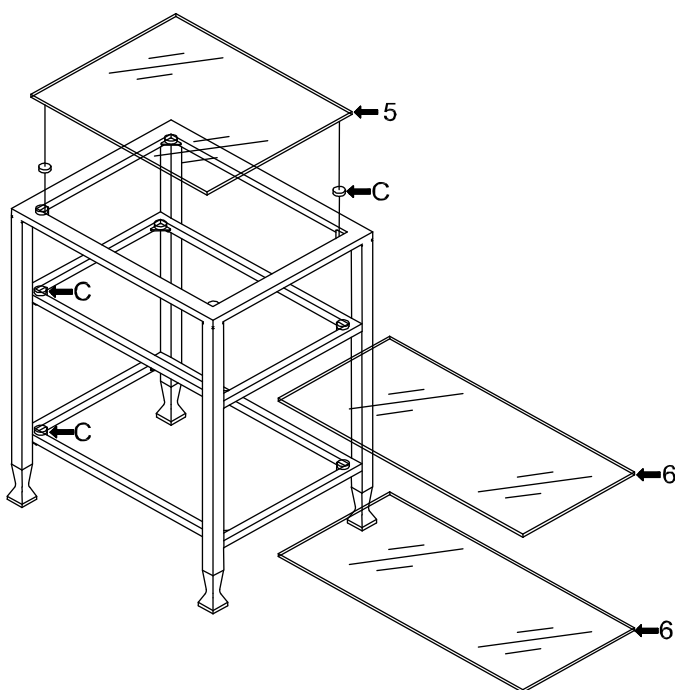

Step 4:

Turn the unit upright, apply the Glass Pads **(C)** onto Top Frame, then, place Glass Top **(5)** and insert Glass Shelf **(6)** as shown.



Southern
ENTERPRISES

Customer Service 1-800-633-5096
service@seidal.com
Southern Enterprises, Inc.
600 Freeport Parkway Suite 200
Coppell, Texas 75019

Parts Replacement Form

Customer Information

Name _____

Address _____

City/State/Zip Code _____

Phone Number _____

Please indicate where you purchased this item: Store/Website/Catalog

Please indicate color/size/style number:

Style No	Parts Letter	Parts Description	Quantity Needed
_____	_____	_____	_____
_____	_____	_____	_____
_____	_____	_____	_____

Please immediately examine this product carefully. Any request for missing parts or damage replacement must be received within 90 days of your receipt of the product. Replacement, if available, will be honored within this time frame. Parts will not be available for items arriving fully assembled. We do not recommend modifying product(s) and we are not responsible for any damages due to product modification(s). If damages or missing parts are not reported within 90 days of your receipt, we are under no obligation to provide parts or replacement merchandise.

Please contact Southern Enterprises at 800-633-5096 or in Dallas 972-869-0111/ 9am – 4pm Mon-Fri Central time if you have product issues or email us at service@seidal.com. Please ask for customer service representative for issues involving damages or replacement parts. Please ask for technical assistance representative for any issues with product and assembly/construction.

Please contact the retailer that you purchased from for returns.



Southern
ENTERPRISES

Customer Service 1-800-633-5096

service@seidal.com

Southern Enterprises, Inc.

600 Freeport Parkway, Suite 200

Coppell, Texas 75019