

PRODUCT DESCRIPTION	GRADE LEVELS	INSTALLATION METHOD
Rigid Vinyl Plank	Above Grade / On Grade / Below Grade	Uniclic Click Lock

## KEY INSTALLATION CONSIDERATIONS

- Mohawk Rigid Vinyl Plank flooring is intended for interior use only and is suitable for above grade, on grade, and below grade applications. **DO NOT** install in any outside areas, saunas, seasonal porches, camping trailers, boats, RVs, lanais, rooms that are prone to flooding, or rooms or homes that are not temperature- controlled.
- Mohawk Rigid Vinyl Plank flooring is a floating floor and should be allowed to expand and contract freely. It must not be glued, nailed, or fastened to the subfloor in any way. Permanent cabinets, vanities, islands and similar items should be installed first. Then, install Mohawk Rigid Vinyl Plank flooring around them, leaving the proper expansion gap. Mohawk Rigid Vinyl Plank flooring can be installed under vanities with legs. Mohawk Rigid Vinyl Plank flooring can be installed under toilets; leave proper expansion space around the flange and use a premium waterproof 100% silicone caulk. Do not anchor toilet through the material.
- Mohawk Rigid Vinyl Plank flooring is a waterproof floating floor, but it should not be used to seal an existing floor from moisture. It cannot inhibit the growth of mold or prevent structural problems associated with, or caused by flooding, excessive moisture, alkalis in the subfloor, or conditions arising from hydrostatic pressure. Regardless of location, always remove standing water, urine and other liquids promptly. Job site moisture issues should be addressed and corrected prior to installation. Fill expansion spaces around potential wet areas only with premium waterproof 100% silicone caulk.
- Long-term exposure to direct sunlight can potentially damage Mohawk Rigid Vinyl Plank flooring, causing it to discolor, fade, or buckle. Protect Mohawk Rigid Vinyl Plank flooring from exposure to direct sunlight via the use of window- treatments or UV-tinting on windows.
- If the flooring is to be installed by a third party, then it is suggested that the homeowner be present during the installation for consultation/ direction. The owner and installer should discuss installation and layout to maximize satisfaction. If this is not possible, consultation should occur prior to installation. The owner/ installer assumes all responsibility for quality of completed installation.

## BEFORE STARTING

Before beginning a Mohawk Rigid Vinyl Plank flooring installation project, it is critical that you 1) fully acquaint yourself with the detailed installation instructions for your specific flooring and subfloor type and 2) conduct a complete job site evaluation.

- For appropriate installation information, review this guide and the assembly instructions provided on each carton of flooring you purchased.
- Make a complete job site evaluation to assure that environmental conditions are acceptable for Mohawk Rigid Vinyl Plank flooring installation. No acclimation is required if the product temperature is between 45°F to 115°F (7°C to 46°C) and site conditions are between 45°F to 115°F (7°C to 46°C), with an inside relative humidity below 85% for 48 hours prior to, during and 48 hours after installation. For more detail, please reference the "Installation Prep" section of this guide.
- Determine the quantity of Mohawk Rigid Vinyl Plank floorings, flooring transitions and wall trim needed for your installation. It is recommended that you add an additional 10% to your square footage for standard installations to account for cuts. For diagonal installations, add 15%.
- Make sure you have the appropriate installation tools. A list of recommended installation tools can be found in the "Tools Required for Installation" section of this guide.
- Cartons should be evenly stacked no more than five cartons high on a flat surface and away from any heating/cooling ducts or direct sunlight.

## TOOLS REQUIRED FOR INSTALLATION

- Tape Measure
- Utility Knife
- Eye Protection
- Gloves
- Tapping Block
- Soft Faced Hammer
- Pull Bar
- 1/4" Spacers
- Level
- Reciprocating Saw (*optional*)
- Miter or Circular Saw (*optional*)
- Knee Pads (*optional*)

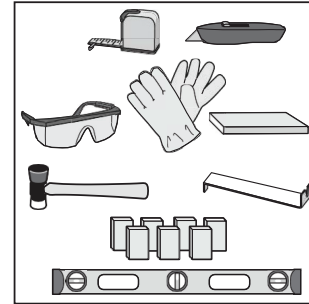

## Site Preparation

Prior to installation, the homeowner or installer must ensure that job site conditions (*including subfloor/ substrate, ambient temperature and relative humidity*) will not negatively affect the floor. The manufacturer is not responsible for damages associated with improper installation or poor site conditions.

- The surface of the subfloor must be flat. The flatness requirement is defined as follows: the maximum difference between two high points and the intermediate low point is 1/4" in a 10' radius. Surface flatness must also not vary more than 1/16" when measured with a 3' straight edge. Additionally, the subfloor must not slope more than 1" in 6'.
- High areas can be sanded, ground down or floated over with an approved self-leveling compound. Fill excessive voids or low areas using a non-gypsum, cementitious based leveling compound. Allow the leveling compound to dry thoroughly before beginning the Mohawk Rigid Vinyl Plank flooring installation. Follow the manufacturer's instructions to be sure it is appropriate for the application.
- Subfloors must be structurally sound without deflection.

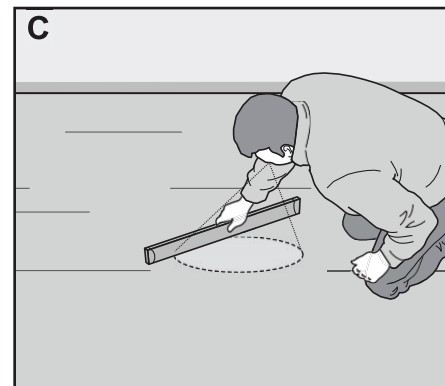
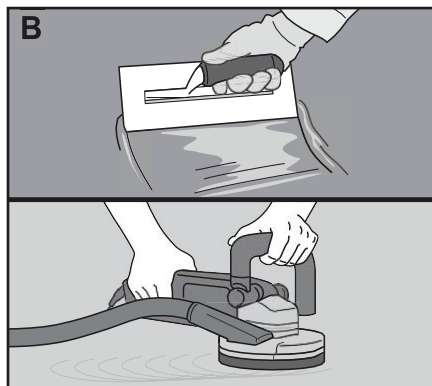
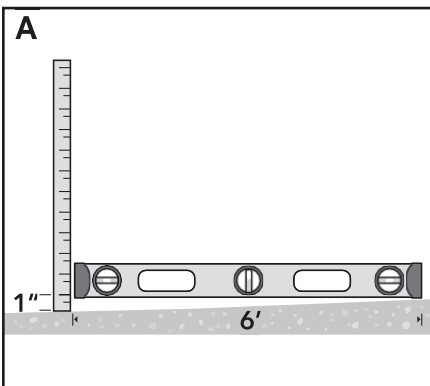

- D. Crawl Spaces: Concrete slab or ground must be dry. Ensure that crawl spaces have open vents year- round to ensure proper air circulation and prevent moisture build-up. The ground in the crawl spaces must be completely covered using 6 mil polyethylene. Crawl space clearance between the earth and underside of joists should be no less than 18" (45.7cm) and the perimeter vent area should be equal to 1.5% of the total square footage of the crawl space or as mandated by code.
- E. Carefully remove any existing quarter round or base board molding.
- F. Always remove carpet, carpet pad and tack strips.
- G. Remove any existing floating or un-adhered flooring.
- H. Be sure the surface of the subfloor is flat, clean, dry and sound before starting.
- I. Inspect every plank for any shipping damage when removing from the carton.
- J. Kitchen cabinets must be installed before the floor is installed. Do not install cabinets on top of Mohawk Rigid Vinyl Plank flooring.

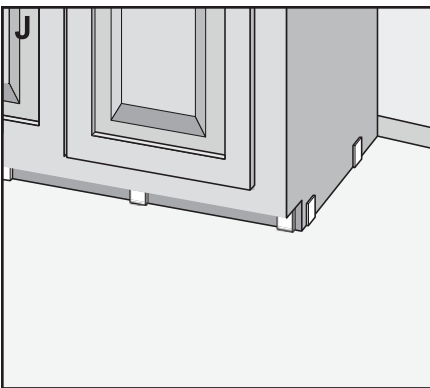
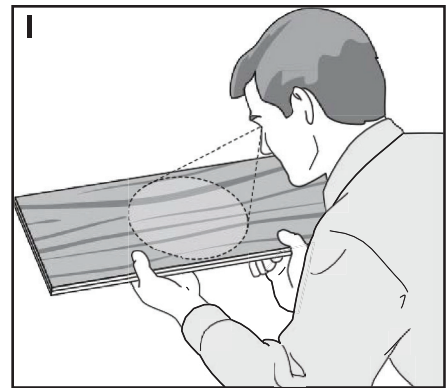
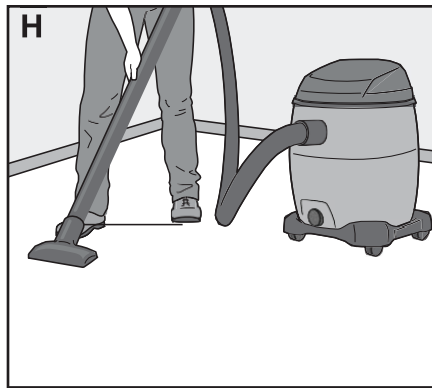
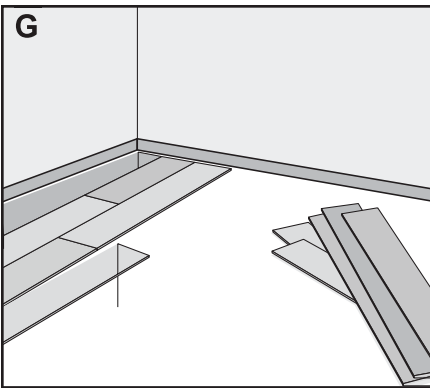
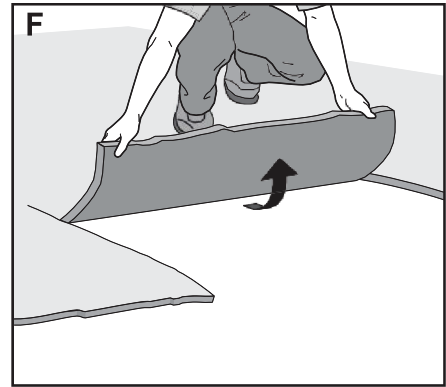
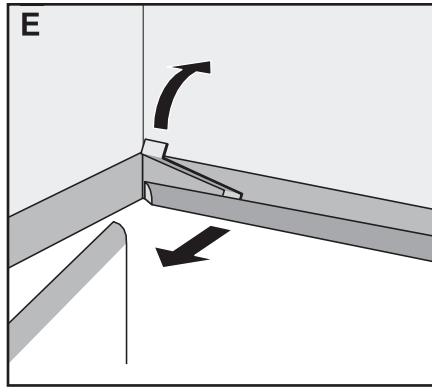
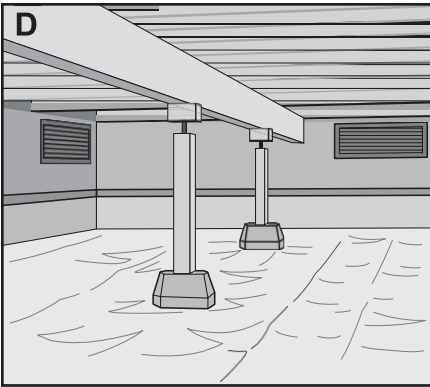



## APPROVED SUBFLOORS:

Concrete, Plywood, OSB, Particleboard, Chipboard, Hardwood (*Solid, Engineered, Parquet*), Tile (*Ceramic, Terrazzo, Stone, Asbestos, Peel and Stick*), Non-Cushion Sheet Vinyl, Metal, VCT, DRIcore

All subfloor requirements noted below must be met prior to the installation of Mohawk Rigid Vinyl Plank.

### Concrete Subfloor Prep

- Perform moisture tests at locations around exterior doorways, near walls containing plumbing, near foundation walls and in the center of the room.
- High spots can be removed by grinding; depressions can be filled with patching compound formulated for use in floor installation.
- Cure for at least 90 days (*applies to newly-laid concrete slabs*).
- Can be either sealed or unsealed.
- Moisture levels of concrete slabs before, during and after installation must be  $\leq 8$  lbs/1000ft<sup>2</sup>/24-hr using an anhydrous calcium chloride test according to ASTM F1869 and pH must be between 5.0 and 9.0; or, if using ASTM F2170 IN-Situ Probes, should be less than 90% RH (*relative humidity*). Always measure, record and keep your testing results.

### Wood (*Plywood, OSB, Particleboard, Chipboard, Solid Hardwood, Luan*) Subfloors

- Wood subfloors must be A.P.A. approved with a minimum grade of "BB" or "CC". For reference, A.P.A. is the acronym for an organization originally known as the "American Plywood Association", and that is now known as "The Engineered Wood Association".
- Perform moisture tests using a reliable moisture meter in multiple locations. Moisture readings should never exceed 14% for plywood, OSB, particleboard, chipboard and solid hardwood subfloors. If moisture readings exceed 14%, it should be corrected at the job site before installing Mohawk Rigid Vinyl Plank.

### Other Subfloor Prep

- Adhered and sound vinyl sheet goods, linoleum and resilient (*VCT*) tiles: Old vinyl and linoleum tiles or sheet goods normally do not need to be removed if they are fully bonded and free of any notable damage. Some older vinyl sheet goods and tile contain asbestos. Should it contain asbestos special precautions must be taken for your safety. Contact a professional immediately for inspection and removal.
- Ceramic tiles and terrazzo: Old flat ceramic tiles normally don't need to be removed. Grout joints wider than 1/4" must be filled. Usually, Mohawk Rigid Vinyl Plank flooring products can be installed directly over ceramic tiles and terrazzo providing they are fully adhered, smooth, sound and dry. These flooring materials must be smooth and flat to within 1/4" in a 10' radius and must not vary more than 1/16" when measured with a 3' straight edge.
- Do not install over more than one layer of vinyl.

### Radiant Flooring Heating Prep

- After market radiant heated floors must be approved by the manufacturer for use with resilient flooring applications. The subfloor temperature should not exceed 85°F (29°C).

### NON-APPROVED SUBFLOORS:

- |                            |                                     |                          |
|----------------------------|-------------------------------------|--------------------------|
| • Carpeting/Carpet Pad     | • Parquet Over Concrete             | • Hardwood Over Concrete |
| • Cushioned Vinyl Flooring | • Cork                              | • Rubber                 |
| • Floating Floors          | • Engineered Hardwood Over Concrete |                          |
| • Laminate                 | • Sleeper Substrates                |                          |

Remove the floors noted above and remove old adhesive before installing Mohawk Rigid Vinyl Plank flooring.

## GENERAL MOHAWK RIGID VINYL PLANK FLOORING INSTALLATION INSTRUCTIONS

- Mohawk Rigid Vinyl Plank flooring products are intended for indoor use only.
- Temperatures within the room must be maintained between 0°F to 140°F (-18°C to 60°C).
- These extreme ranges between 0°F to 45°F (-18°C to 7°C) and 115°F to 140°F (46°C to 60°C) are for unoccupied environments only. Occupied areas as well as the installation need to be controlled between 45°F to 115°F (7°C to 46°C).
- A 1/4" (6 mm) expansion space must be provided around the perimeter of the room and any fixed objects such as pipes or columns.

- Use approved safety equipment to provide proper protection based on each given task.

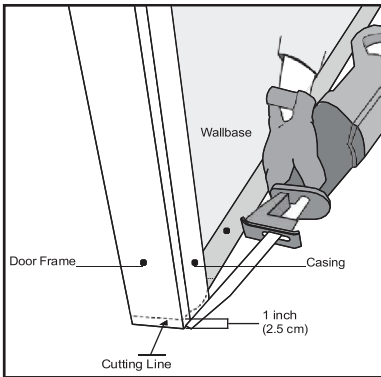

- Door-jamb and casings must be undercut so that the plank can slide underneath. A 1/4" (6 mm) expansion space must also be included around the undercut jamb and casings. A reciprocating saw is recommended to create the necessary undercut. Never undercut metal door casings. Cutting Tip: To undercut the casing, lay a scrap piece of flooring next to the casing and lay the saw flat on top of the flooring so that the saw easily cuts to the height of the plank.
- Important—Always inspect each plank to make sure it is not damaged prior to installation. Check the tongue and groove to assure it is free of debris or damage.
- When installing flooring from two or more cartons, check the pattern, color and batch numbers on the carton to ensure they are all the same. This information is listed on the exterior label of each carton. It is recommended to blend flooring from multiple cartons during installation.
- Cartons should be evenly stacked no more than five cartons high on a flat surface and away from any heating/cooling ducts or direct sunlight.

- Excess flooring should be stored in a protected climate controlled environment for future repairs if necessary.
- Power tools can be dangerous. Operate in strict accordance with manufacturer's operating instructions and safety precautions. Unsafe and improper use can cause serious injuries. Avoid inhalation and exposure to airborne particles by wearing personal protective equipment, including: NIOSH or OSHA approved dust masks, safety goggles and work gloves.

## MOHAWK RIGID VINYL PLANK FLOORING CLICK LOCK INSTALLATION INSTRUCTIONS

1. Inspect each plank. Floor should be installed blending planks from several cartons at the same time to ensure good color and shade mixture throughout the installation.
2. It is recommended that installation begin in a corner of the room with the tongue facing the wall. Between the first row of flooring and the wall, insert spacers so that a 1/4" (6 mm) gap is created.
3. When installing the first row, insert the short edge of one plank into the short edge of another plank at a slight angle and rotate downward. Continue to complete the starter row maintaining a straight edge for the following row.

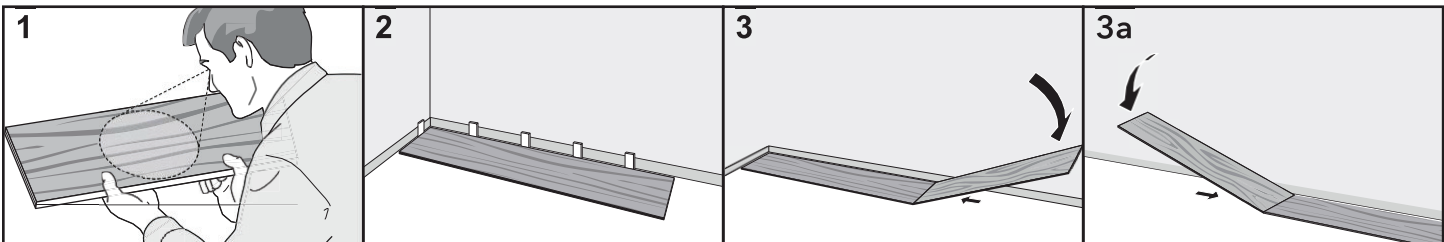

4. Use a tapping block and soft faced hammer to close any gaps between the planks.
5. Once you reach the end of the first row, measure and cut the final plank so that it completes the row while also leaving the necessary 1/4" expansion gap. Last planks of rows must be at least 8" long.

Note: Use a spare plank to create a straight edge at the cut line. Use a utility knife to score the top of the pattern and snap the panel. It will be necessary to cut the foam underlayment after snapping the panel.

6. Start the second row of flooring by trimming a plank to a length different from the first plank in the first row. First and last pieces must be at least 8" long. End joints should be staggered a minimum of 6".
7. At a slight angle, insert the long edge tongue of the first plank in row 2 into the long edge groove of the plank in row 1 until the plank edges meet, and then rotate down until the joints lock.
8. When joining the next plank to the first plank in the row, join the short side edges first. There will be a gap on the long side joints when the plank is rotated down.
9. Raise the outside long edge of the plank upward approximately 1". This will raise the outside long edge of planks in that row. Maintain this angle as you push the plank in until the long edge of the plank meets the long edge of the first row. Rotate downward on the plank until the joint locks.
10. After tapping the long side joint closed, close the short edge joints using a tapping block or pull bar.
11. Repeat these steps to complete the installation.
12. After each row is complete, ensure there will be a 1/4" (6 mm) gap (after the joints are closed) to the wall for expansion.

13. For the last row, align the plank to be used on top of the 2nd to last row. Using a full width plank as a spacer, trace the wall contour. Use a full plank as a straight edge to cut the plank. Insert the long edge tongue in to the long edge groove and use a pull bar and hammer to close the gap.
14. After tapping the long side joint closed, close the short edge joints using a tapping block or pull bar.

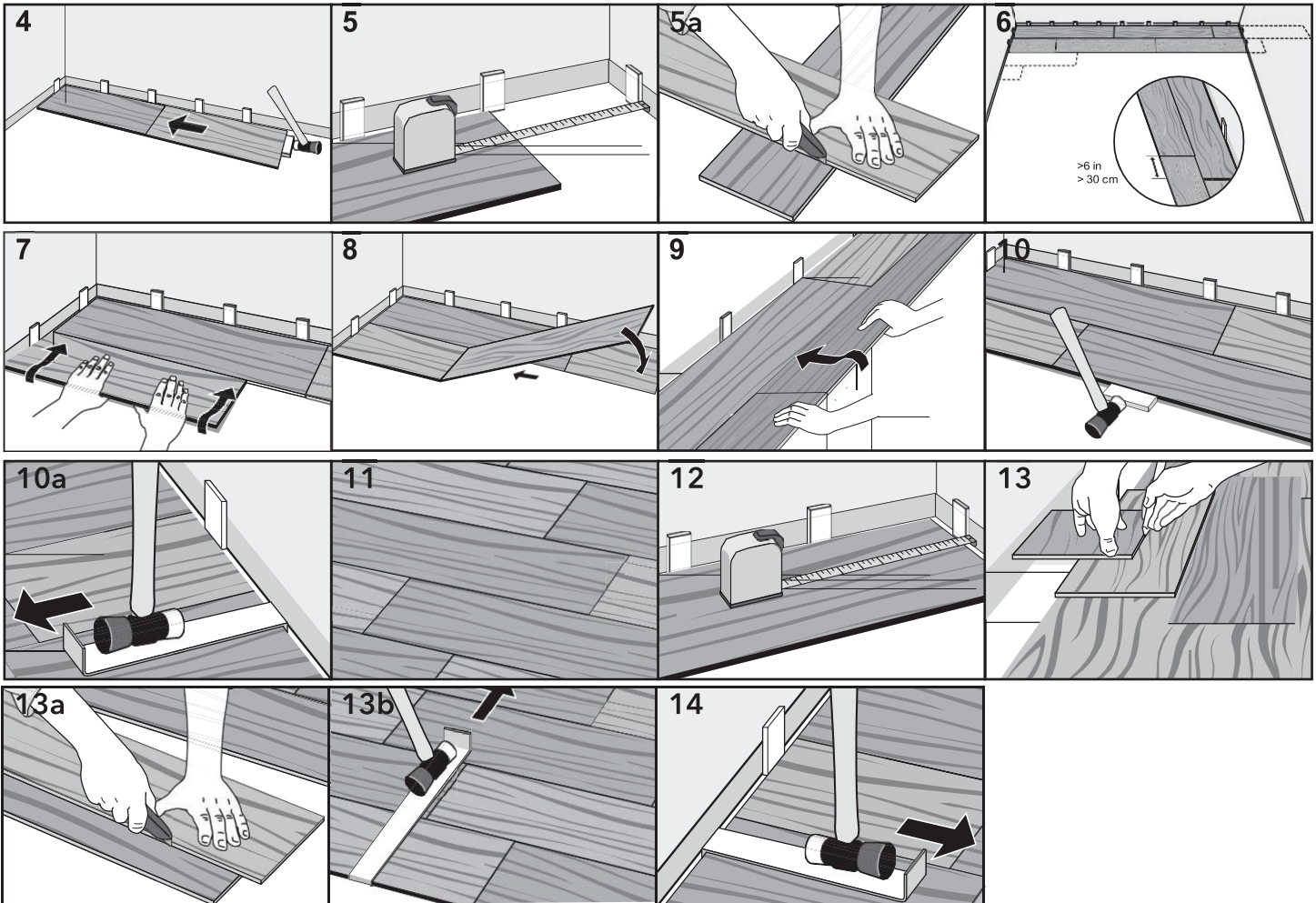

### Installing Under Doorway Frames

15. When the new flooring meets a threshold or a doorway, we recommend undercutting the door jamb. To secure the right cut, turn a plank upside down and place it on the floor up to the door frame. Then place a reciprocating saw flat against the plank and simply cut through the frame. Remove the cut-out piece and vacuum away debris. Slide plank under pre-cut door frame. Door frame should be cut so that a  $\frac{1}{4}$ " (6 mm) gap is located from the edge of the plank under the casing to the wall.
16. Tap the long side joint closed first, then tap the end joint closed.

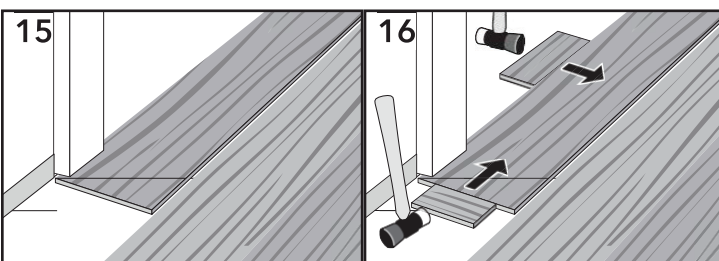

### Installing Around Fixed Objects

17. Allow  $\frac{1}{4}$ " (6 mm) expansion space around pipes or other fixed objects.
18. In rows where there is a pipe, make sure the pipe falls exactly in line with the short side of two planks. Select a drill bit with the same diameter as the pipe plus  $\frac{1}{2}$  inch (13 mm). Click the planks together on the short side and drill a hole centered on the joint between the two planks. Then install the planks.
19. For a double pipe, drill a hole equivalent to the diameter of the pipe plus  $\frac{1}{2}$  inch (13 mm) at each of the marked points. If located on the long side of the plank, make a  $45^\circ$  cut from each hole to the edge of the plank. Then, using an appropriate glue along the cut edges of the piece you cut out, glue the piece



in place. Be sure no glue comes between the cut-out piece and the subfloor.

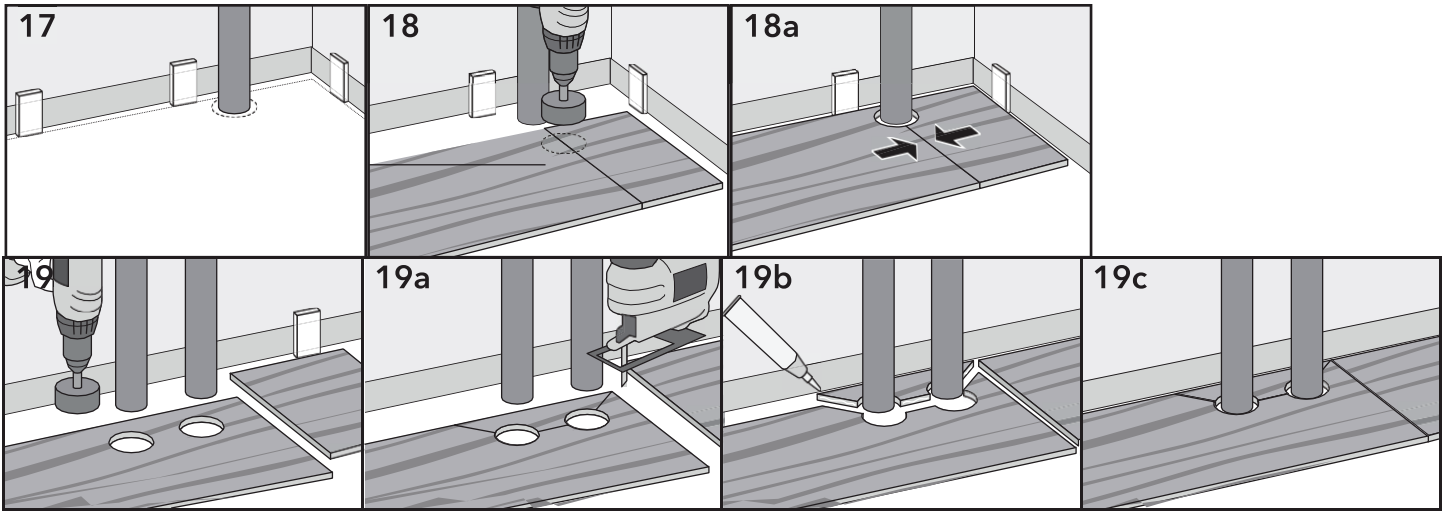

### Finishing the Installation

20. Remove all spacers.
21. Fill any expansion spaces around potentially wet areas (such as refrigerators, tubs, etc.) with premium, waterproof 100% silicone caulk.
22. Remember, the use of coordinating T-Molds is required when installing Mohawk Rigid Vinyl Plank flooring in a room or area that is larger than 100 lineal feet (30.5 meters) in any direction, so that the floor is separated into sections that are no larger than 100ft. x 100ft. (30.5 meters x 30.5 meters) per section.
23. Install moldings to cover the expansion gap. When installing moldings, never allow nails or screws to enter the Mohawk Rigid Vinyl Plank flooring or the expansion zone around the flooring perimeter. All moldings and transition strips need to provide a 1/4" (6 mm) expansion space as well. (Note: Coordinated moldings can be purchased on [homedepot.com](http://homedepot.com). Follow molding installation instructions for proper installation.)

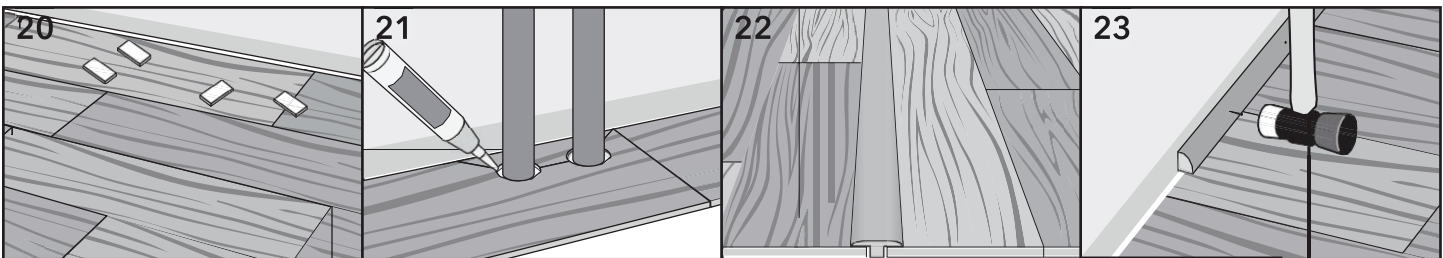

## CARE AND CLEANING

### Preventative Maintenance

- Prevent indentations and scratches by using non-staining floor protectors on the legs of chairs, appliances and all heavy furniture. Floor protectors should be at least 1" in diameter. Periodically clean protectors to remove grit that may become embedded and cause scratching.
- Chair casters should be rubber - not plastic or metal - and should be kept clean.
- Place walk-off mats at entrances. Mats should have a non-rubberized backing and be marked as non-staining.
- We recommend the use of a hard surface (non-studded), non-rubber chair mat to protect your floor from office chairs with casters. Light, rolling furniture should be outfitted with broad-surface, non-staining casters that have been engineered for hard surface floors. Such casters should be a minimum of 1" (2.5cm) wide and at least 2" (5.1cm) in diameter.
- Keep pets' nails trimmed.
- Remove shoes with cleats, spikes or exceptionally pointy heels before walking on the floor.

### Cleaning & Maintenance

- Sweep the floor regularly with a soft bristle broom to remove loose dirt.
- Wash the floor with non-abrasive, neutral PH floor cleaner approved for vinyl floors.
- For every day cleaning, a mop moistened with warm water will suffice.



**Do Not Use the Following on Mohawk Rigid Vinyl Plank flooring**

- Detergent based cleaners
- Abrasive or mop and shine products
- Ammonia
- Vacuum cleaner with a rotating beater bar engaged

NOTE: Always read the cautionary information on all cleaners prior to use.

IMPORTANT: Never push, pull or drag furniture, appliances or other items across the floor. When moving furniture or heavy items, always lift and carry the items.