

Installation and operating manual

English

Garage Door Opener Direct Drive 3/4 HP

synoris 550 compact



Table of contents

1. Important safety information	3	10.3. Installation requirements and dimensions	25
1.1. About this manual	3	10.4. Installation	26
1.2. Access to this manual	3	10.5. Connection	27
1.3. Transfer of the manual	3		
1.4. Operating this opener	3	11.Wall Station	28
1.5. Intended use of the opener	3	11.1. Installation Step 13 - Install the Wall Station	28
1.6. Explanation of the warning symbols used in this manual	3	11.2. Functions	28
1.7. Labels on the product	4	11.3. Installation requirements and dimensions	28
1.8. Explanation of the symbols used in this manual	4	11.4. Installation and connection	29
2. Product and functional description	5		
2.1. The opener and its mode of operation	5	12.Initial operation	32
2.2. Safety equipment	6	12.1. Installation Step 14 - Installing light bulbs	32
		12.2. Installation Step 15 - Program the transmitter	32
3. Technical data	7	12.3. Learning the forces of the door	34
		12.4. Test the emergency release	35
4. Dimensions	8	12.5. Test the obstacle detection function	35
		12.6. Test the photo eyes function	36
5. Storing and items included in the delivery	9	12.7. Attach the warning labels	36
5.1. Storage	9		
5.2. Contents of opener	9	13.Operation	37
		13.1. Lights	37
6. Tools and protective equipment	12	13.2. Operating the opener with the transmitter	37
6.1. Tools required	12	13.3. Operating the opener with the wall station	38
6.2. Personal safety equipment	12	13.4. Emergency release from the inside	39
		13.5. Indicator lights on the control housing	40
7. Installation dimensions and requirements	13	13.6. Resetting the values/ forces	40
7.1. Important installation instructions	13		
7.2. Door types and accessories	13	14.Settings	41
7.3. Installation requirements	14	14.1. Overview of special functions	41
		14.2. Setting the DIP switches	42
8. Installation	15		
8.1. Preparation	15	15.Terminal Connections	43
8.2. Installation Step 1 - Determine the door's highest position	18		
8.3. Installation Step 2 - Install the Header Bracket	19	16.Maintenance and care	44
8.4. Installation Step 3 - Attach the rail to the Header Bracket	19	16.1. Maintenance schedule	44
8.5. Installation Step 4 - Hang the opener	20	16.2. Regular maintenance	44
8.6. Installation Step 5 - Mounting the door bracket	21	16.3. Maintenance work	44
8.7. Installation Step 6 - Attach the door arm	21		
8.8. Installation Step 7 - Check running of the door	22	17.Troubleshooting	45
8.9. Installation Step 8 - Shorten the length of the emergency release cord	22	17.1. Troubleshooting guide	45
8.10. Installation Step 9 - Set the the limit stops	23	17.2. Photo eyes fault indicators	48
8.11. Installation Step 10 - Attach the Control Housing to the C-rail	23	17.3. Troubleshooting	49
9. Electrical Connection	24	18.Placing out of operation and disposal	51
9.1. Installation Step 11 - Connect to a power outlet or to a permanent wiring connection	24	18.1. Placing the opener out of operation	51
9.2. Power outlet connection	24	18.2. Battery disposal	51
9.3. Permanent wiring connection	24		
		19.Wiring diagram	52
10.Photo Eyes	25		
10.1. Installation Step 12 - Install the Photo Eyes	25	20.Warranty terms and conditions	53
10.2. Function	25		

1. Important safety information

WARNING

Please observe and comply with the following information to avoid possible risk of severe or fatal injury to you and/or other persons.

1.1. About this manual

There is a possible risk of injury or even a risk of death if the following important safety information and the entire contents of this manual are not observed and complied with. The opener may only be installed and operated when all information is observed and complied with.

You must also inform other users of this system about this manual.

1.2. Access to this manual

Keep this manual readily available for later use when dealing with the opener.

1.3. Transfer of the manual

Please be sure to include this manual when the operator is to be installed in a different location and operated by other persons, for example, when selling the opener.

1.4. Operating this opener

This opener may only be operated by adults. Never allow children to operate the opener or to play in the area of the door and the opener.

All users must be trained in the appropriate use of the opener.

The installation, the connection and the initial operation of the opener may only be carried out by technically knowledgeable persons.

All electrical work under voltage may only be performed by a qualified electrician.

1.5. Intended use of the opener

The intended use of this opener is for the opening and closing of garage doors exclusively. Any other use does not correspond with its intended use is not permitted.

The opener may only be used in accordance with its intended use. It must be used safely and responsibly with attention to the instructions and safety warnings in this installation and operating manual.

No modifications may be made to this opener.

The operating license expires if modifications are performed on this device that are not described in this manual or authorized by the manufacturer.

This device complies with Part 15 of the FCC Rules. Operation is subject to the following two conditions:

1. this device may not cause harmful interference, and
2. this device must accept every interference received, including interference that may cause undesired operation.

Malfunctions that could influence the safe operation must be corrected immediately.

1.6. Explanation of the warning symbols used in this manual

The following warning symbols are used in this manual. They warn you about possible dangers.

DANGER

Danger to life or severe personal injury

Please observe and comply with the given information to avoid the possible risk of severe or fatal injury to yourself and/or other persons.

WARNING

Possible danger to life or personal injury

Please observe and comply with the given information to avoid the possible risk of severe or fatal injury to yourself and/or other persons.

1. Important safety information

CAUTION

Possible damage to property

Please observe and comply with the given information to avoid the possible risk of property damage.

1.7. Labels on the product

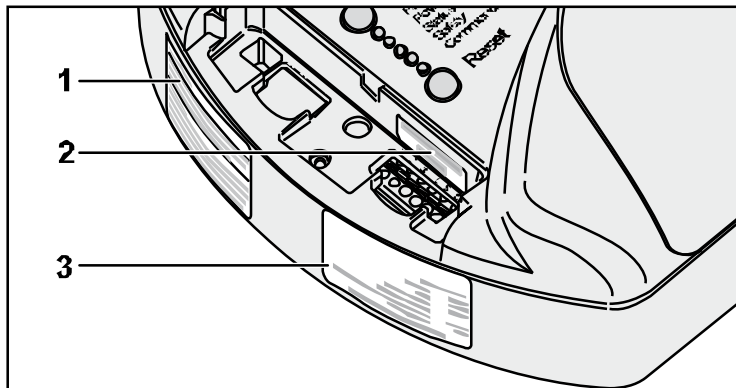

Here you see where the labels are placed on the opener. Observe and comply with the information on the labels and inform others about them.

- 1) Warning information
- 2) Specification to safety low voltage class 2 connections
- 3) Identification label

1.8. Explanation of the symbols used in this manual

Tool symbols

These symbols in the manual show you if you should use specific tools. Here are a few examples:



Phillips screwdriver



Drill with 1/4" diameter wood bit



1/2" open-end wrench



Socket wrench with 3/8" socket

Other symbols



Drilling depth



Only screw in screws loosely, do not tighten yet



Now tighten the screws



It clicks into place and/or a clicking sound can be heard

2. Product and functional description

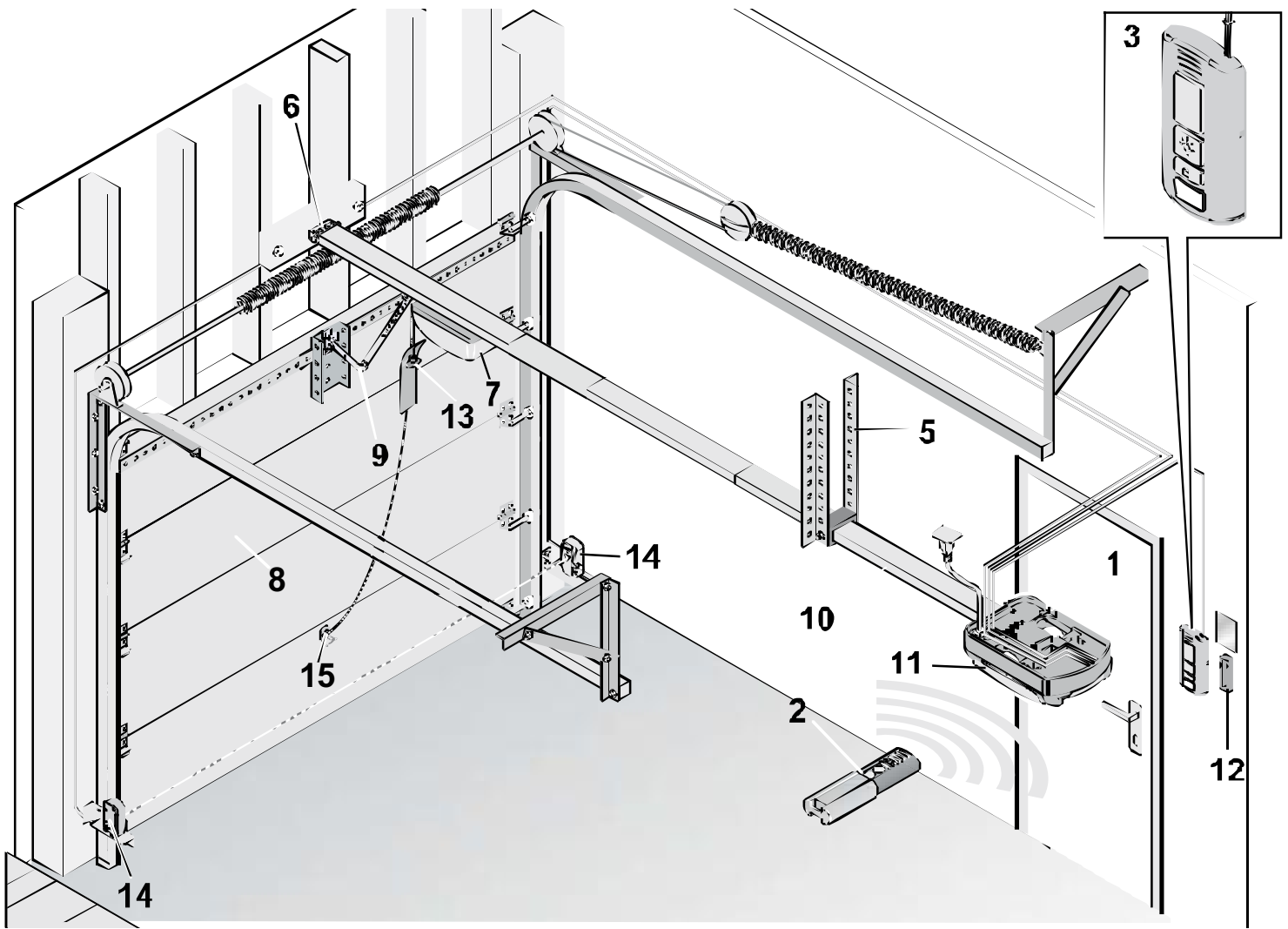

2.1. The opener and its mode of operation

Sectional doors and one piece doors can be opened and closed with this electrically powered opener (1) and its supplied accessories. This opener has been evaluated by UL and is UL listed for the USA and for Canada for use of sectional and one-piece doors. Relevant accessories for these door types are provided in the packaging. Use of this opener for other types of doors may be possible with different accessories, but has not been part of the evaluation done by UL. Please ask your qualified dealer or SOMMER USA for further advice.

The opener is controlled via a transmitter (2), or a wall station (3).

The opener is mounted to the ceiling structure (5) and to the header (lintel) (6) over the garage door opening. A carriage (7), which is attached to the door (8) by a door arm (9) moves along a stationary chain in the opener rail (10) and opens or closes the door.

The integrated light (11) is automatically activated during operation. It can also be independently activated via a transmitter (2) or a wall station (3) without the opener being in operation.

Using the wall station (3), the opener can be locked during longer periods of absence (e.g. travel/vacation).

The transmitter can be stored in a holder (12) (accessory) in the garage and the vehicle so it does not get lost.

2. Product and functional description

2.2. Safety equipment

The opener switches off if it encounters an obstacle and protects people from injury and vehicles or other objects from damage. If the door stops because of an obstacle during closing, it will open completely.

In the event of a power failure, the door can be opened from the inside by pulling the emergency release handle (13).

The photo eye set (14) safeguards the door. If the photo eyes are disrupted, the closing procedure is stopped. If the door stops during closing because of the photo eyes, it will open completely.

Emergency release from outside (accessory)

WARNING

There is a possible risk that people could be locked into the garage.

In an emergency situation (e.g. power failure), it must be ensured that you can open the door without the opener or be able to get into the garage by another means. If the garage does not have a separate entrance or the garage door does not have a built-in door, you must install an emergency release (15) (accessory) that can be operated from outside.

3. Technical data

	Direct Drive 3/4 HP
Supply voltage	AC 120 V
Rated frequency	50/60 Hz
Storage locations in the radio receiver	20
Lighting	2 x maximum 60 W, standard bulb (not included in the package)
Runtime	30 sec.
Battery in the transmitter	Type CR 2032, 3 V
Working environment based emission value	< 75 dBA – operator only
Max. pulling and pushing force	550 N
Rated pulling force	165 N
Rated current consumption*	1.4 A
Rated power consumption*	150 W
Max. door weight**	550 lbs (250 kg)
Power consumption Standby	approx. 6 W

* Values are valid without lighting

** Depending on the door and its running characteristics

4. Dimensions

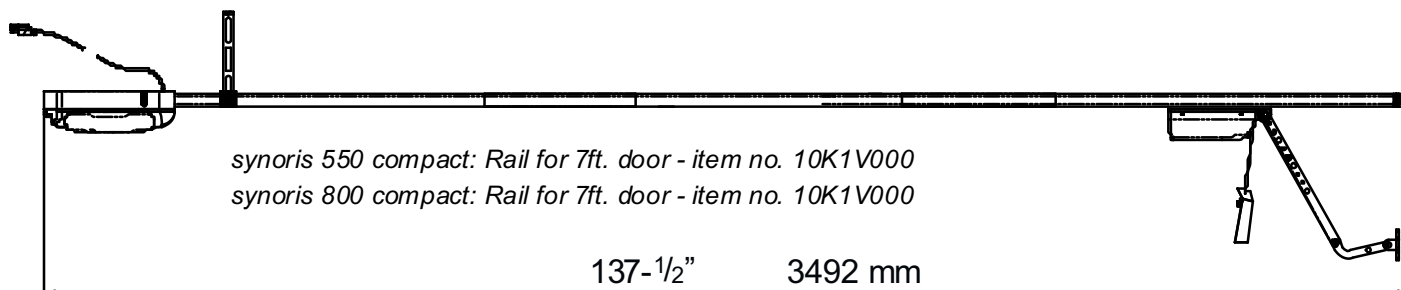

Note

For taller doors, rail extension must be installed (accessory).

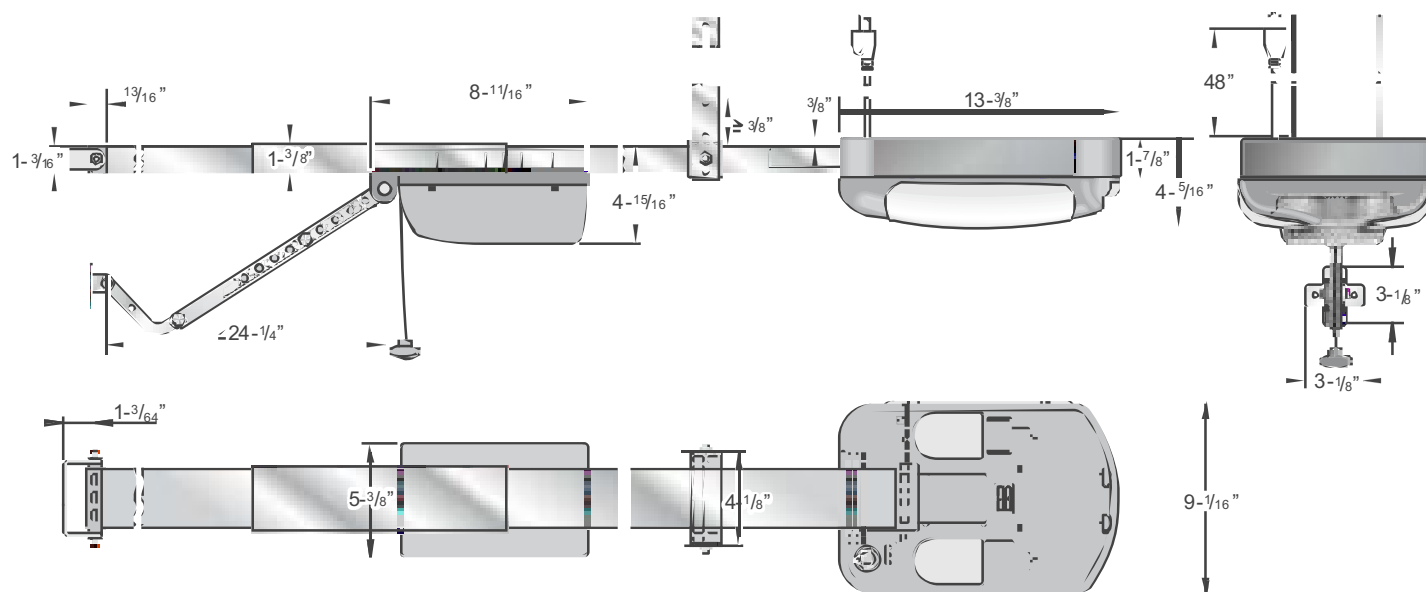

5. Storing and items included in the delivery

5.1. Storage

CAUTION

There is a possible risk of damaging the opener if it is not stored correctly.

Store the opener in the following way only:

- laying flat
- in closed and dry rooms

5.2. Contents of opener

When unpacking, please check to make sure that all items are included in the boxes. Should something be missing, please contact your qualified dealer/ salesperson, they will gladly be of further assistance.

Please dispose the packaging material properly according to your local waste regulations.

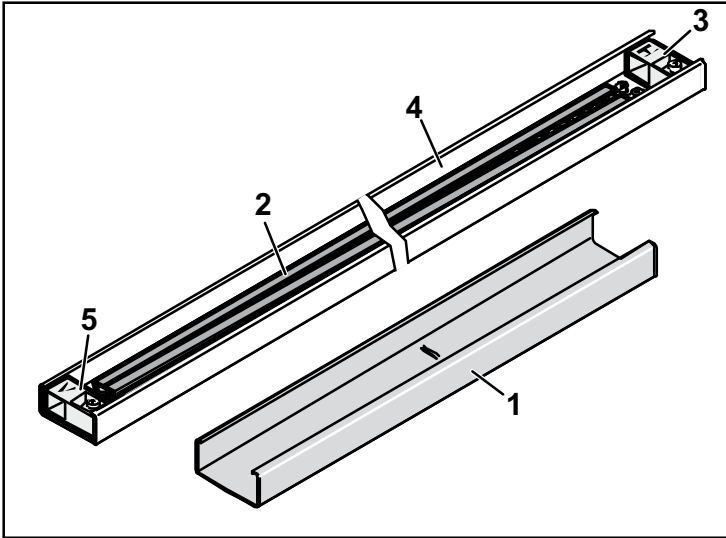

A Rail package

- 1) 2 Connecting sleeves
- 2) 1 Chain in (three-piece) chain channel (chain channel is made of plastic. It is not packaging material – therefore do not remove!)
- 3) 1 Limit stop marking H
- 4) 3 C-rails
- 5) 1 Limit stop marking V

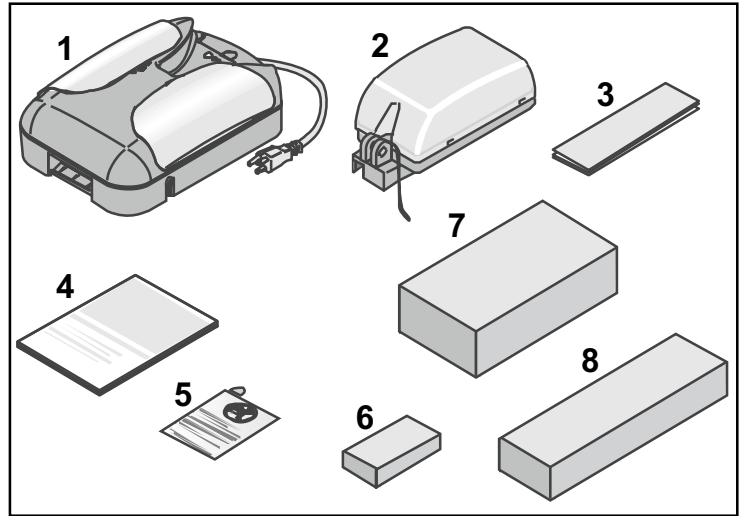

B Opener package

- 1) 1 Control housing (with power cable) including radio receiver
 - 2) 1 Motor carriage (with emergency release)
 - 3) 1 Safety and maintenance guide
 - 4) 1 Power Glider installation and operating manual
 - 5) 1 Warning label
 - 6) 1 wall station, see separate list
 - 7) 1 Installation package
 - 8) 1 Photo eye set, see separate list
- * Light bulbs for the light are not included in the package.

5. Storing and items included in the delivery

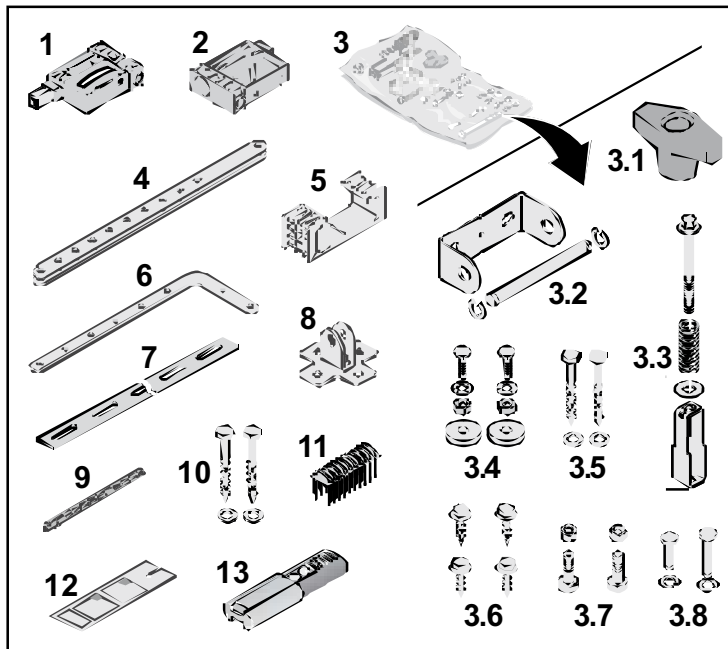

- 4) 1 Door arm
- 5) 1 ceiling bracket
- 6) 1 Curved door arm
- 7) 1 Perforated Strip Iron
- 8) 1 Door bracket
- 9) 1 Fastening bolt for control housing
- 10) 2 Screws 8 x 60 mm (wrench size 1/2") and 2 washers 5/16" for the attachment to the ceiling
- 11) 3 x 10 staples
- 12) 1 Warning tag for emergency release
- 13) 2 Transmitter, including battery

C Installation package (see graphic B, Pos. 7)

- 1) 1 Slide-in part in the C-rail (with contact)
- 2) 1 Slide-in part in the C-rail
- 3) 1 Installation bag with the following content:
 - 3.1) 1 Emergency release handle
 - 3.2) 1 Header bracket and pin with 2 locking c-clips
 - 3.3) 1 Tensioning bolt M8 x 80 mm (wrench size 3/8"), 1 tensioner, 1 washer and 1 spring for the slide-in part
 - 3.4) 2 Carriage bolts M8 x 25 mm with 2 nuts M8 (wrench size 1/2") and 2 toothed lock washers 5/16" for the ceiling bracket
 - 3.5) 2 Screws 8 x 60 mm (wrench size 1/2") and 2 washers 5/16" for the attachment to the header
 - 3.6) 4 Self-tapping screws 1/4" (wrench size 3/8") for the door bracket
 - 3.7) 2 Bolts 3/8" x 1" (wrench size 9/16") with 2 self-locking nuts 3/8" (wrench size 9/16") for connecting the curved door arm with the door arm
 - 3.8) 1 Pin (short) with locking c-clip feature for boomerang attachment to the door bracket and 1 Pin (long) with locking c-clip for door arm attachment to the motor carriage

5. Storing and items included in the delivery

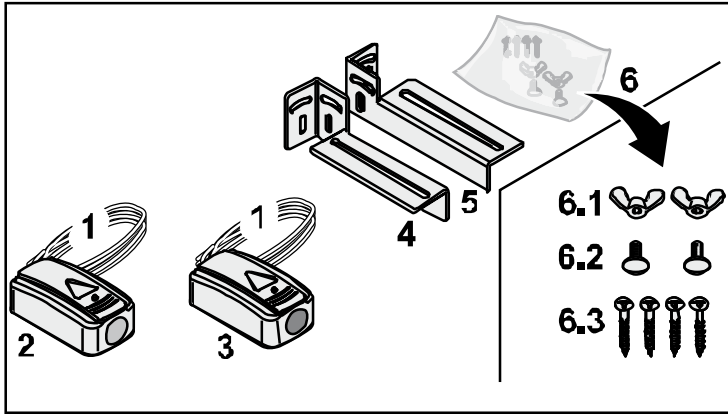

D Photo eye set (see graphic B, Pos. 6)

- 1) 2 wires, length 32' 9" (10 m)
- 2) 1 Transmitter photo eye (green sticker)
- 3) 1 Receiver photo eye (red sticker)
- 4) 1 Mounting bracket left
- 5) 1 Mounting bracket right
- 6) 1 Installation bag with the following content:
 - 6.1) 2 Wing nuts M6
 - 6.2) 2 Carriage bolts M6
 - 6.3) 4 Wood screws 6 x 40 mm for attaching the mounting bracket

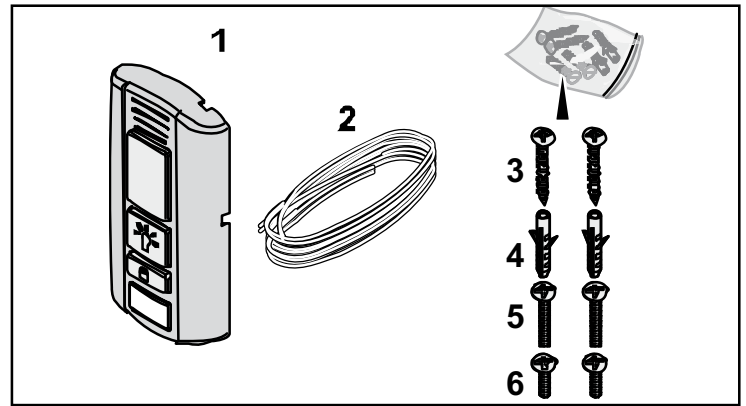

F Wall station (see graphic B, Pos. 8)

- 1) 1 Wall station
- 2) 1 wire length 32' 9" (10 m)
- 3) 2 Wood screws 1/8" x 1.2" for wall attachment
- 4) 2 Anchors 3/16"
- 5) 2 Screws 6-32 x 1" for attaching to a electrical box
- 6) 2 Screws 1/8" x 3/8"

6. Tools and protective equipment

6.1. Tools required

You will need the following tools for assembling and installing the opener. Lay out the required tools. This ensures a quick installation.

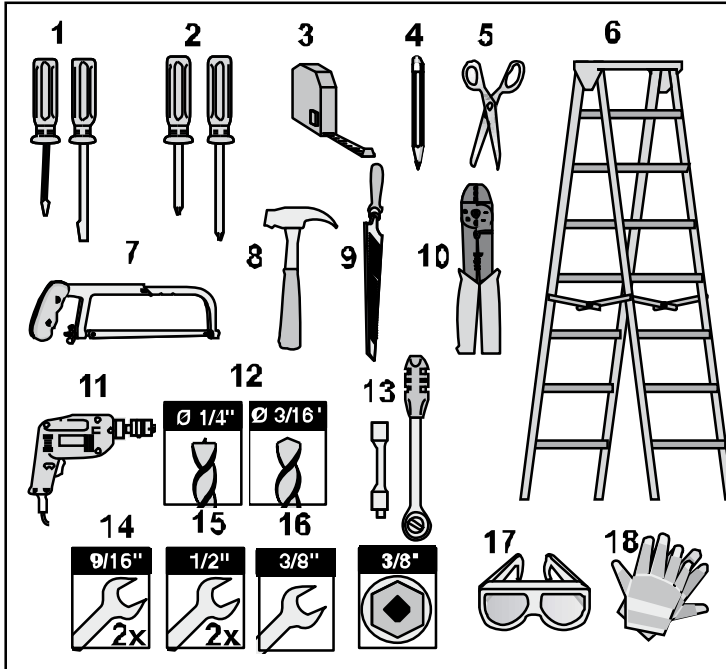

- 1) Slotted screwdriver, (1x small and 1x medium)
- 2) Phillips screwdriver, (1x small and 1x medium)
- 3) Measuring tape
- 4) Pencil
- 5) Scissors
- 6) Step-ladder
- 7) Hack saw
- 8) Hammer
- 9) File (fine grade)
- 10) Wire stripper
- 11) Drill
- 12) Drill bits for metal and wood
Wood: Ø 1/4"
Metal: Ø 3/16"
- 13) Socket ratchet with 3/8" socket
- 14) 2 Open-end wrenches 9/16"
- 15) 2 Open-end wrenches 1/2"
- 16) Open-end wrench 3/8"

6.2. Personal safety equipment

⚠ WARNING

There is a possible risk of injury when working with tools. Please protect yourself against possible injury during the installation of the opener. Use the following protective equipment:

- 17) Safety glasses (for drilling)
- 18) Protective gloves (e.g. when handling cut-off pieces of perforated strip steel)

7. Installation dimensions and requirements

7.1. Important installation instructions

⚠ WARNING

WARNING – to reduce the risk of severe injury or death:

1. READ AND FOLLOW ALL INSTALLATION INSTRUCTIONS.
2. Install only on a properly balanced garage door. An improperly balanced door has the potential to cause severe injury. Have a qualified service person make repairs to cables, spring assemblies, and other hardware before installing the opener.
3. Remove all ropes and remove or make all locks connected to the garage door inoperative before installing opener.
4. Where possible, install the door opener 7 feet or more above the floor. For products having an emergency release, mount the emergency release 6 feet above the floor.
5. Do not connect the opener to source of power until instructed to do so.
6. Locate the wall station: (a) within sight of door, (b) at a minimum height of 5 feet that small children are not able to reach it and (c) away from all moving parts of the door.
7. Install the visible Warning label next to the wall station in a prominent location. Install the Emergency release tag. Attach the tag on or next to the emergency release.
8. After installing the opener, the door must reverse when it contacts a 1-1/2-inch high object.

⚠ WARNING

There is a possible risk of injury or death if a door does not fulfill the following conditions. The opener may only be installed when the following installation requirements and installation dimensions are met.

7.2. Door types and accessories

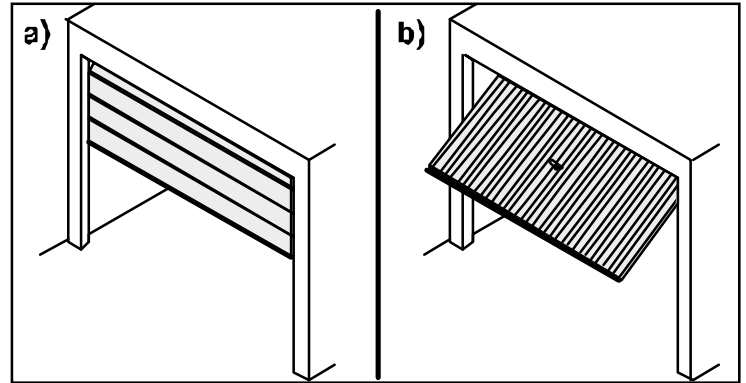

⚠ WARNING

To reduce the risk of injuries. Use this opener only with a sectional door (a) or a one piece door (b).

This opener has been evaluated by UL and UL listed for the USA and for Canada for use with sectional and one-piece doors and relevant accessories for these door types are provided in the packaging. Use of this opener for other types of doors may be possible with different accessories, but has not been part of the evaluation done by UL. Please ask your qualified dealer or SOMMER USA for further advice.

7. Installation dimensions and requirements

7.3. Installation requirements

The installation of the opener cannot compensate for a poorly installed or defective installation of the door.

Only install the opener on a correctly aligned and easy running door. Ask your qualified dealer for advice.

An improperly aligned door can cause serious injury.

The door must be stable, i.e. when opening and closing, it must not bow, sag or twist because high operational forces act on the door during opening and closing.

Reinforce lighter doors made out of plastic or aluminum if necessary prior to the installation. Ask your qualified dealer for advice.

In all other cases, no additional weight-increasing parts may be attached to the door system or the opener. This can lead to dangerous situations such as i.e. breaking of the door mechanics or overloading the opener.

The opener may only be installed in dry indoor rooms where there is no risk of explosion.

The installation location must be protected against dust and splashed water.

The opener may not be installed in areas that have an aggressive climate.

Walls and ceiling must be solid and stable.

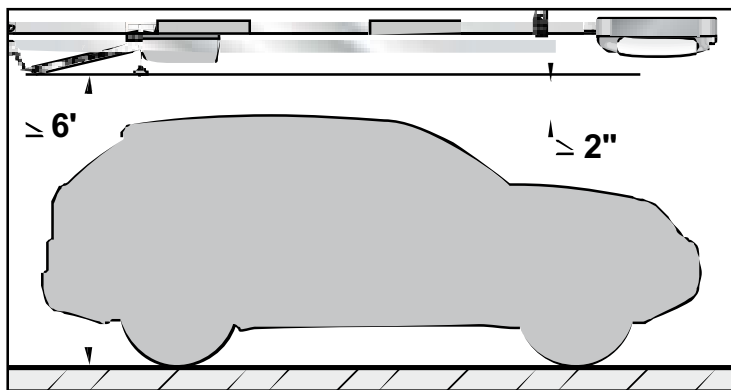

Attach the opener at a height of at least 6' (1,83 m) above the floor and a minimum distance of 2" (50 mm) to the vehicle including all attached vehicle accessories such as a roof rack etc.

The door may not be part of a fire-protection installation which closes the door automatically in the event of a fire. The automatic closing is prevented with the installation of the opener.

Observe and comply with valid local building regulations.

⚠ WARNING

There is a possible risk of injury or death if a door is not balanced. The door's functioning can be impeded and uncontrolled movements could be the result.

The door must be balanced. See "checking door balancing". If the door and the door mechanics require repair or adjustment as a result of the check, this may only be performed by qualified, qualified dealer.

Checking the balance

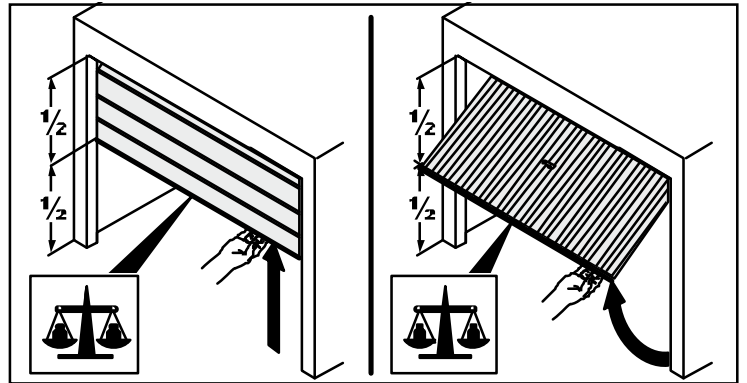

The door must be able to be moved easily by hand and be balanced. Perform the following test prior to the installation to determine if the door is balanced:

- Manually open the door half-way.
The door must remain in this position. If the door moves upwards or downwards, the door needs to be adjusted.
Ask your qualified dealer for advice.

8. Installation

8.1. Preparation

Check to make sure that all required parts are included in the package before you begin the installation. This ensures a quick installation.

⚠ WARNING

There is a possible risk of injury or death if you do not observe and comply with the following information. Observe and comply with all listed instructions prior to installation.

The installation, the connection and the initial operation of the opener may only be carried out by technically knowledgeable persons.

Only move the door when there are no persons, animals or objects in the area of movement.

Always wear safety glasses when drilling the mounting holes to protect your eyes from flying chips.

Wear protective gloves when handling burred materials.

Be careful when climbing or standing on a ladder while performing work on the opener. Be sure you have a secure footing.

CAUTION

There is a possible risk of property damage if you do not observe and comply with the following information. Observe and comply with all listed instructions before the installation.

Cover the opener so no dirt or contamination can get into the opener if you have to drill in the area of the opener.

Remove or disable all door locks before the installation.

For a sectional door, remove the hand rope.

The mounting materials are designed for wooden garage constructions and wood/metal garage doors. Only use the supplied mounting material. Please consult your qualified dealer if you require other mounting equipment for different materials.

Pre-assembly

Attach the emergency release handle

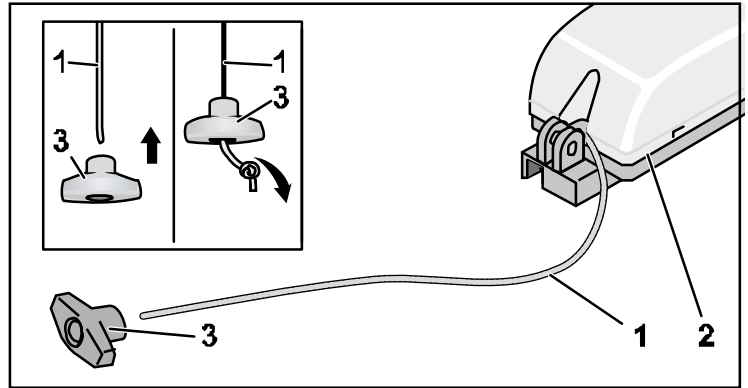

1. Feed the cord (1) of the emergency release (motor carriage) (2) through the hole in the handle (3).
2. Tie a knot at the end of the cord (1) and push the handle (3) towards the knot.

The final cord length can be shortened at the end of the installation after the opener is attached to the ceiling.

Rail pre-assembly

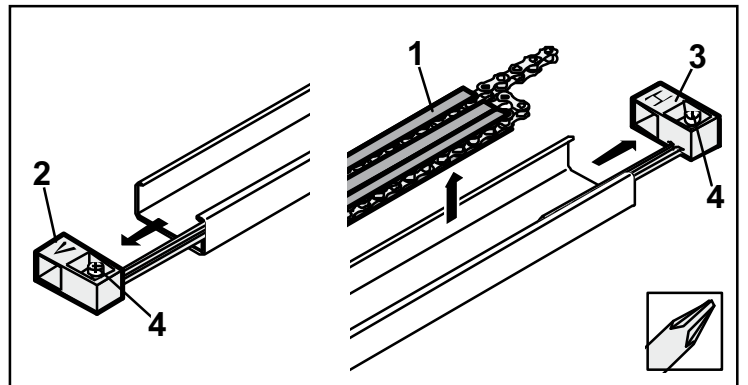

1. The chain (1) is inserted into the plastic chain channel (2). The chain channel guides the chain and also isolates the chain from the C-rail (3).
Please do not remove!
2. Loosen the screws (4) with a phillips screwdriver, take out the limit stops (2+3) and the chain guide (1).

8. Installation

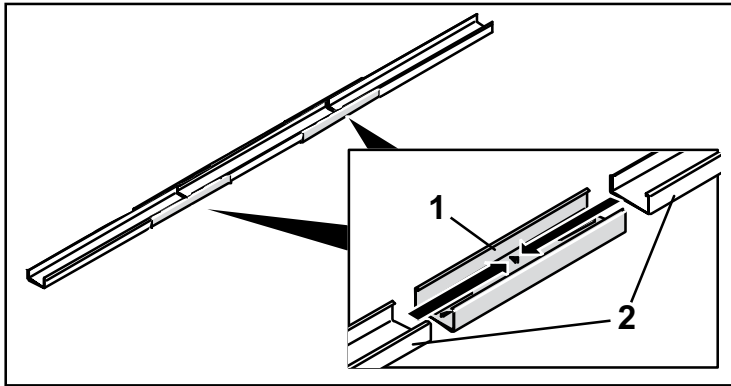

3. Insert the C-rails (2) into the connecting sleeves (1) all the way to the stop position.

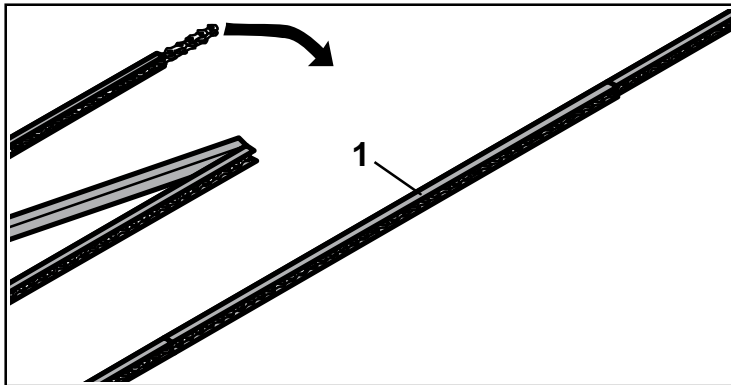

4. Unfold the chain guide (1).

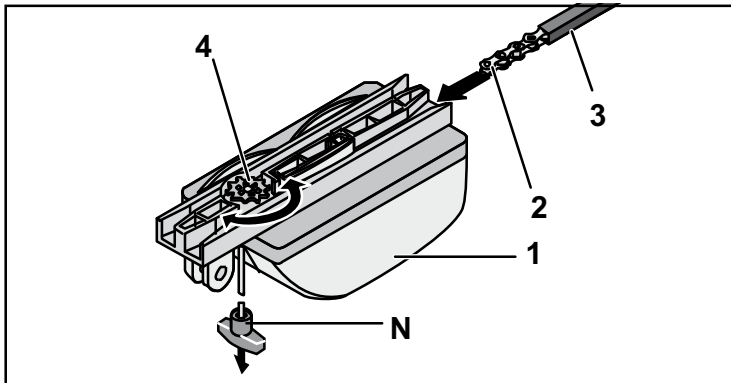

5. Slide the carriage (1) onto the chain (2) with the chain channel (3) (note the position of the chain with the chain channel, see picture). The chain (2) engages into the chain wheel (4). If the chain wheel does not rotate, pull once on the handle of the emergency release cord (N).
■ The chain wheel is now disengaged and the chain can be guided into the motor carriage.

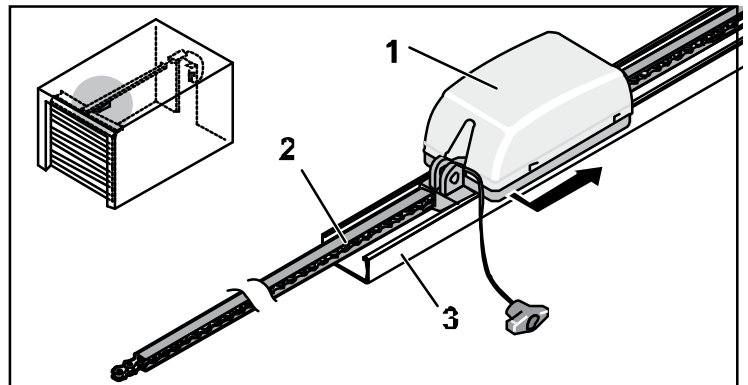

6. Slide the carriage (1) together with the chain (2) into the C-rail (3) and slide it to the middle of the rail.

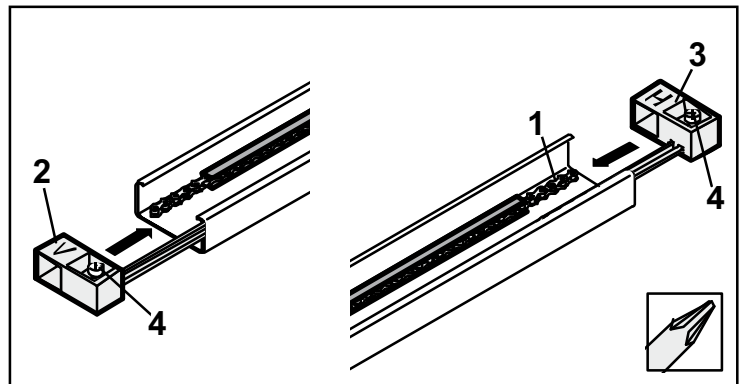

7. Insert the limit stops (2+3) into the rail (1). Feed the chain (1) through the opening hole in the limit stop. Fix the screws of the limit stops with a phillips screwdriver.

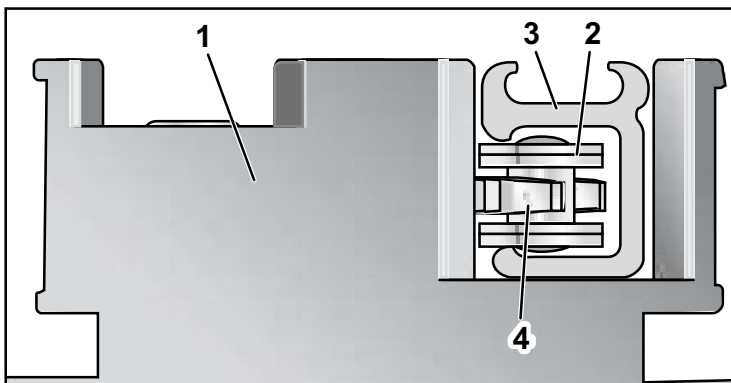

8. Installation

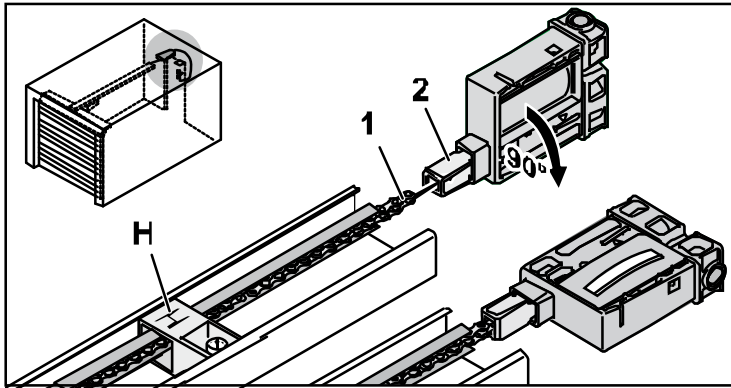

Outside of the C-rail:

8. Feed the first link of the chain (1) into the tensioner (2) and turn by 90°. The limit stop (with the marking H) remains in the C-rail.

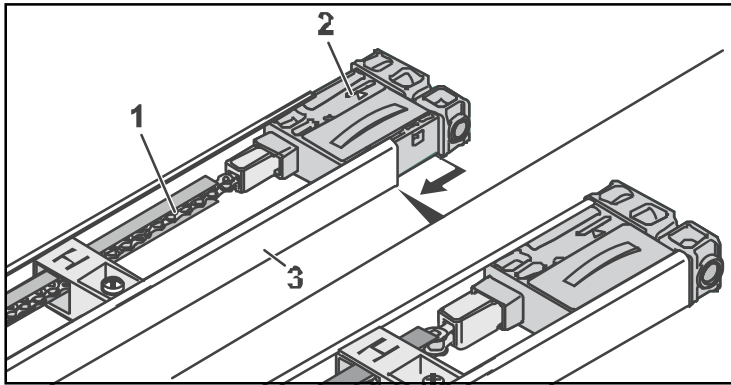

9. Slide in the slide-in part (2) together with the chain (1) into the rail (3). Final position see graphic.

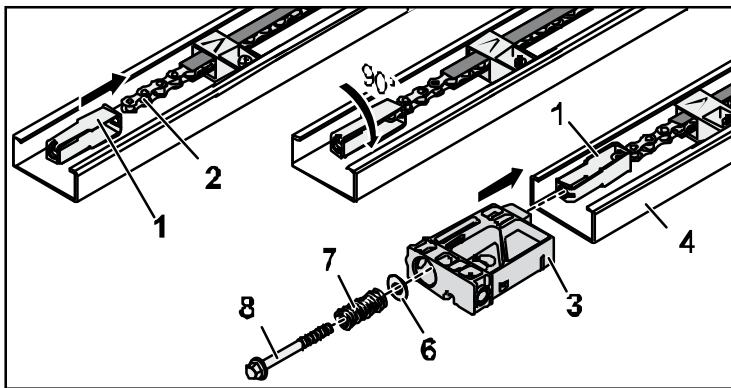

On the opposite side of the C-rail:

10. Attach tensioner (1) to chain (2) and turn it by 90°.
11. Insert slide-in part (3) in the C-rail (4) and place the tensioner (1) into the opening of the slide-in part (3).
12. Place the washer (6) and the spring (7) on the tensioning bolt (8) M8 x 80 mm (8) and screw the tensioning bolt into the tensioner (1) by hand.

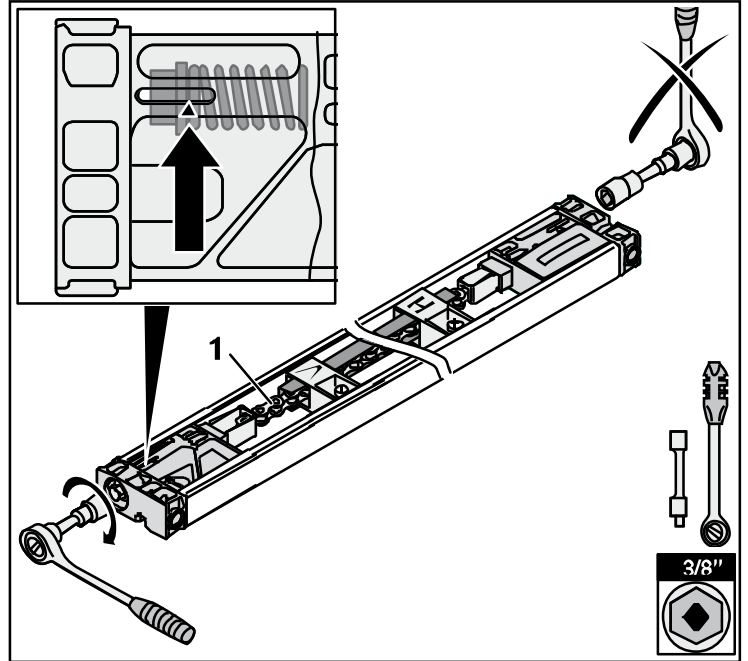

13. Tighten the chain (1) using a 3/8" socket wrench up to the marking. Arrow has to line up with collar of the tensioning bolt.

Caution

The pre-installed slide-in part on the opposite side has been already pre-tensioned at the factory and must not be tightened any further. Attempting to tighten further can damage or destroy the tensioner.

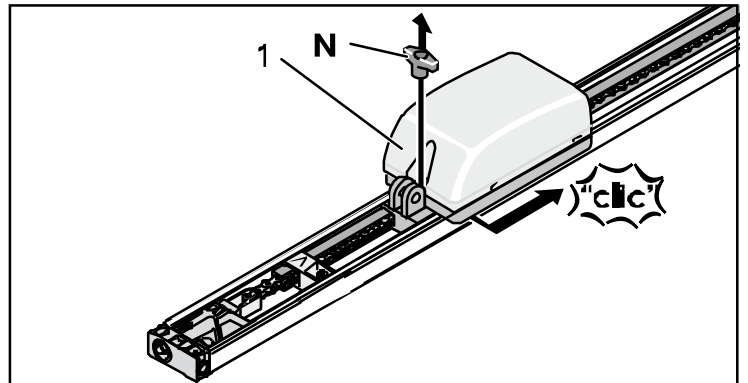

14. To set the motor carriage (1) into position, pull the emergency release cord (N) once. Then move the carriage until it locks into place.

8. Installation

Ceiling bracket pre-assembly

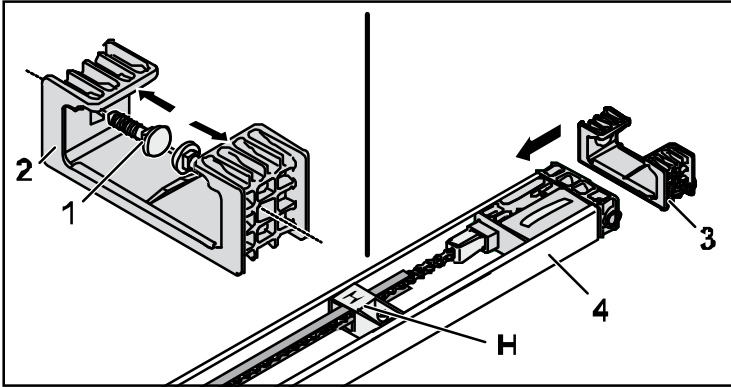

1. Insert the carriage bolts M8 x 25 mm (1) into the ceiling bracket (2).
2. Slide the ceiling bracket (3) onto the C-rail (4) (from position H).

8.2. Installation Step 1 - Determine the door's highest position

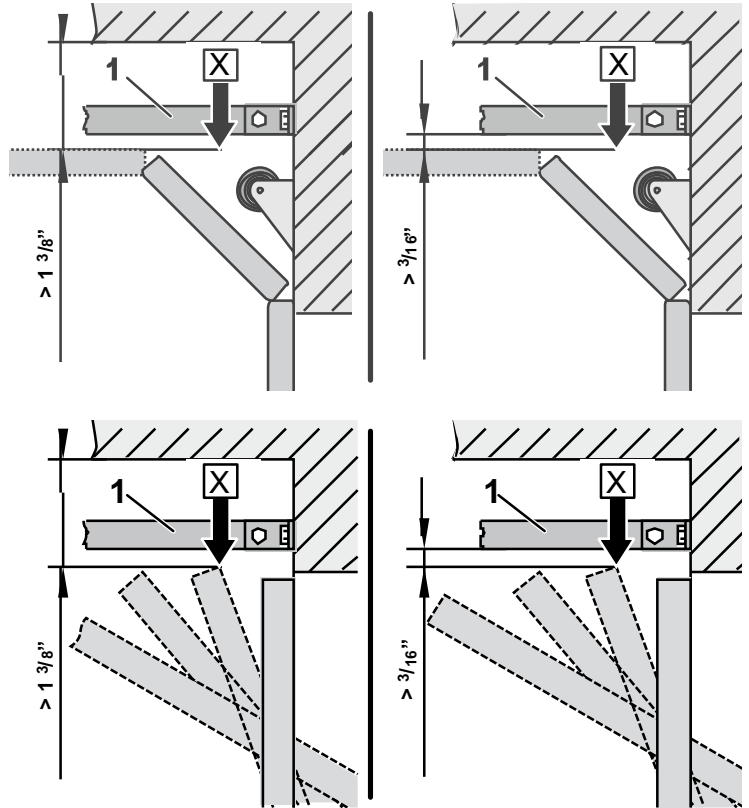

X = DHP (Door's highest position)

- 1) Open the door and measure the distance between the top edge of the door and the ceiling where the clearance is the smallest. This point is called the door's highest position (DHP). This distance must be at least 1-3/8" (35 mm). The distance between the DHP and the lower edge C-rail (1) must amount to at least 3/16" (5 mm). If the clearance is less, the opener must be moved back and a longer push rod must be attached. Please ask your qualified dealer.

Note:

Please observe that this distance may possibly be reduced if a door handle is attached to the middle of the door. The door must be able to run freely.

8. Installation

8.3. Installation Step 2 - Install the Header Bracket

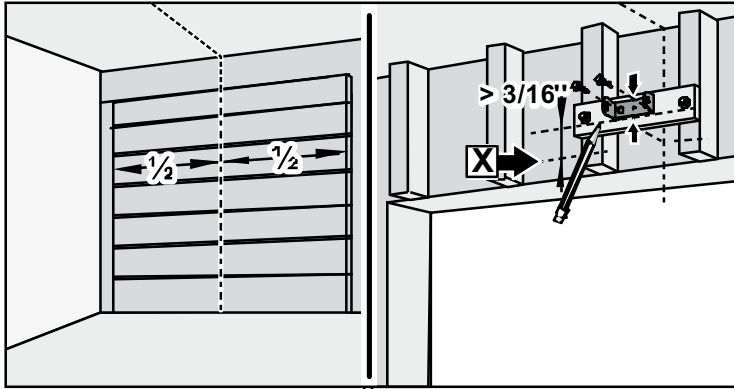

1. Close the door.
2. Determine the door's center point and mark this on the header as a vertical guide line. Where needed, an auxiliary construction (1) must be mounted.
3. Determine the horizontal guide line for the header bracket and mark it. It must be at least 1-3/8" (35mm) from the door's highest position (X).
4. Center the header bracket on the vertical guide-line and mark the horizontal set of bracket holes.
5. Drill two 1/4" pilot holes at the marked mounting points on the header (lintel). Pay attention to the material strength of the header.
6. Fasten the bracket securely to the header with the provided hardware.

8.4. Installation Step 3 - Attach the rail to the Header Bracket

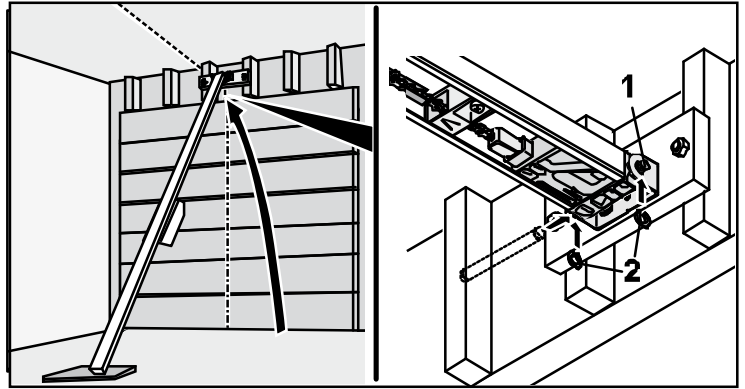

⚠ Warning

Risk of injury from flying chips when drilling. Drilling chips can get into the eyes and injure them.

Always wear safety glasses when drilling.

1. Position the opener on the garage floor below the header bracket. Have someone hold the opener if spring is in the way.
2. Slide the C-rail into the header bracket and secure with the pin. Attach locking c-clips to secure.

8. Installation

8.5. Installation Step 4 - Hang the opener

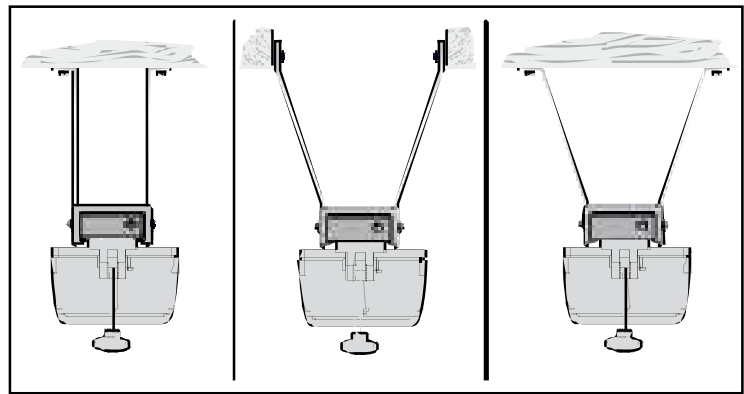
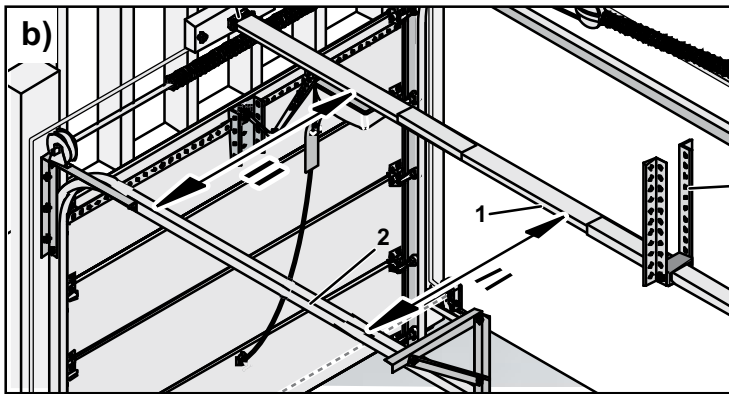
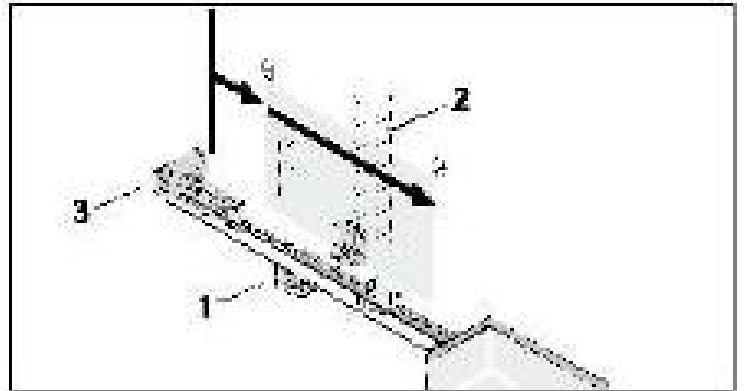
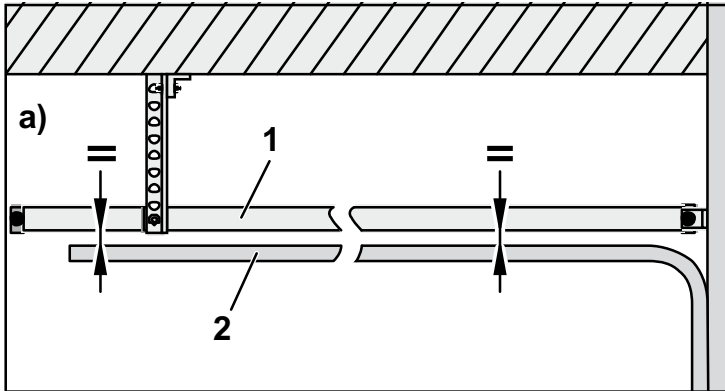

1. Raise the opener onto a ladder. You will need help at this point if the ladder is not tall enough.
2. Open the door all the way and rest the opener on the top section.
3. Align the opener parallel to the running rails of the door (2):
a) in the horizontal direction and
b) in the vertical direction.

4. Select the position for the ceiling suspension bracket (1). The ceiling suspension bracket can be attached i.e. using metal bracket (angle iron) (2) (not supplied). The distance from the ceiling suspension bracket to the end of the C-rail (end of the slide-in part) (3) should be between 6" and 2' (150 and 610 mm). If necessary, an auxiliary construction for mounting the opener must be attached to this location.

8. Installation

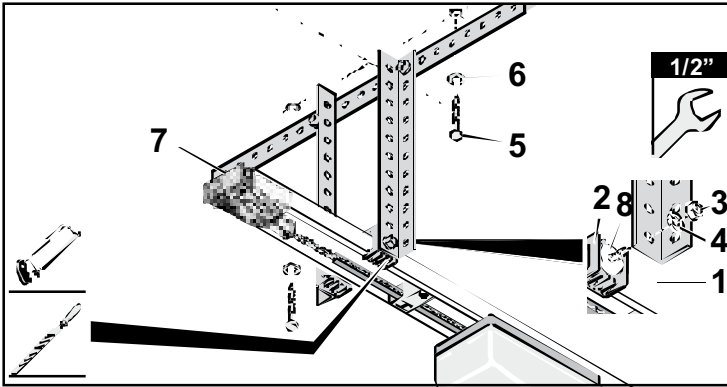

Warning

Risk of injury when handling sawed-off metal brackets due to sharp edges.

Wear protective gloves when you handle the sawed-off metal brackets.

- Place the big washer (8) on the screw in the ceiling bracket (2). Fasten the metal brackets (1) to the ceiling bracket (2) using the nuts M8 (3) and toothed lock washers 5/16" (4) using a 1/2" open-end wrench.

Warning

Risk of injury from flying chips when drilling.

Always wear safety glasses when drilling.

- Once the appropriate position has been determined, mark the corresponding attachment points (observing the guide line) and drill 1/4" pilot holes.
- Attach a sturdy metal bracket to structural supports before installing the opener using two wood screws 8 x 60 (5) with washers 5/16" (6) and tighten with a 1/2" open-end wrench.
- Attach the C-rail (7) to the punched angle iron (1), parallel to the position of the door running rails.
- Tighten the nuts M8 (3) with a 1/2" open-end wrench.
- If necessary, cut off the excessive length of punched angle iron (1).

8.6. Installation Step 5 - Mounting the door bracket

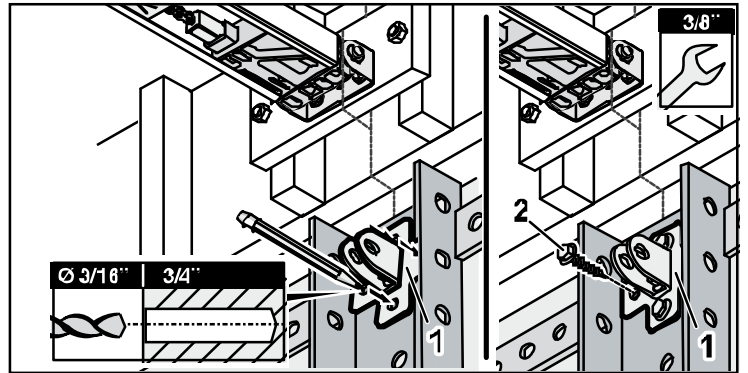

- Close the door.
- Align the door bracket (1) to the center of the door (guide line) and the top section of the door and mark four mounting points.

Warning

Risk of injury from flying chips when drilling.

Always wear safety glasses when drilling.

- Drill four 3/16 pilot holes to a depth of 3/4" (19mm). Pay attention to the material strength of the door.
- Attach the door bracket (1) using four self-tapping screws 1/4" including washers (2) using a 3/8" open-end wrench.

8.7. Installation Step 6 - Attach the door arm

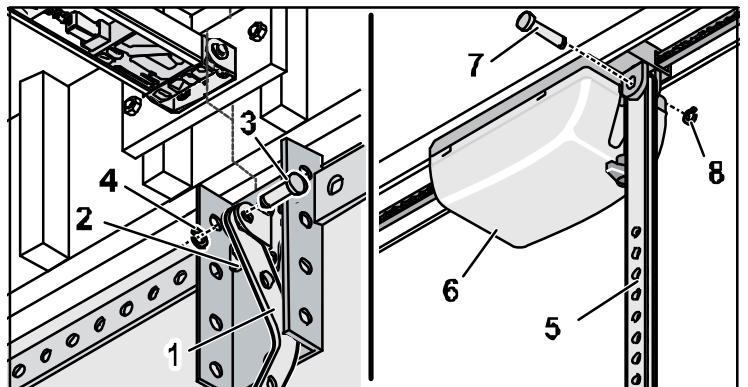

- Attach the curved door arm (1) to the door bracket (2). Guide the bolt, (short) (3) through the hole in the door bracket and in the curved door arm and secure with the locking c-clip (4).

8. Installation

2. Attach the door arm (5) to the motor carriage (6) (the open side of the door arm must be facing towards the ceiling). Guide the bolt, (long) (7) through the holes in the motor carriage and the door arm. Secure with the locking c-clip (8).

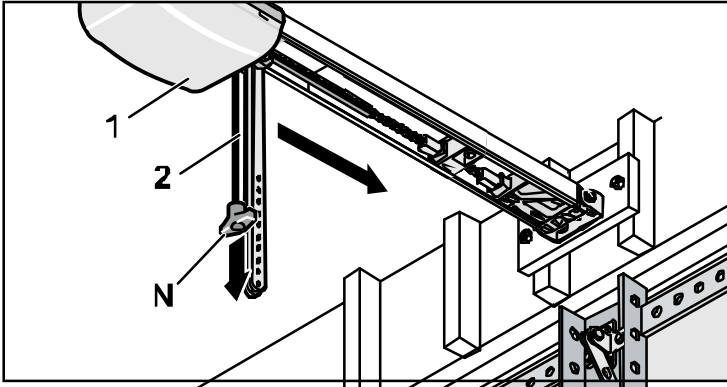

3. Slide the carriage (1) with the door arm (2) all the way towards the door.

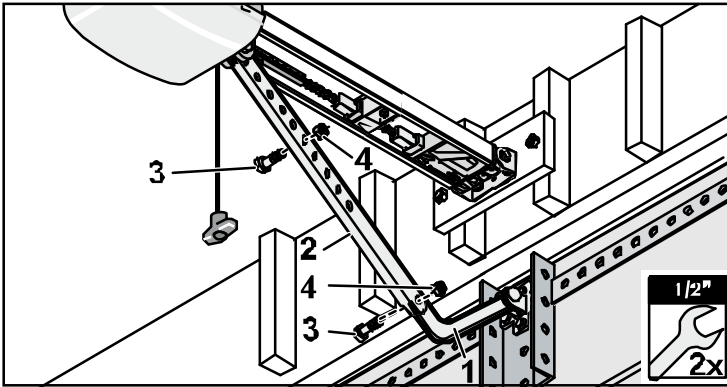

4. Slide the curved door arm (1) into the door arm (2) and secure with two bolts 3/8" (3) and two self-locking nuts 3/8" (4). Tighten the nuts using a 9/16" open-end wrench. While tightening, hold the screws in place using a second 9/16" open-end wrench. Basic position of the screw arrangement see graphic. The length of the door arm can be adjusted if necessary.

8.8. Installation Step 7 - Check running of the door

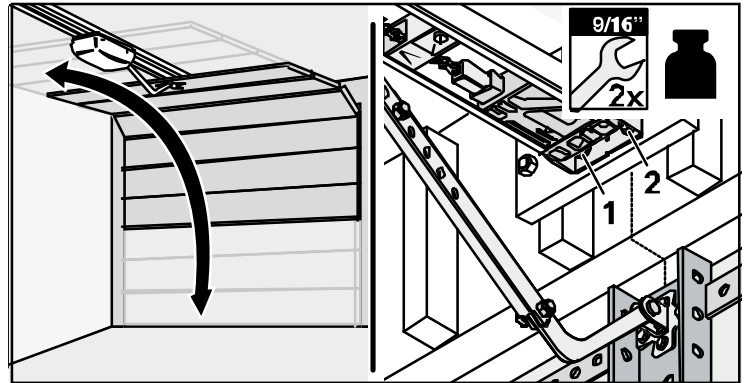

- 1) Manually open and close the door completely. Check if the door runs easily.
- 2) Make sure all screws and attachment are tight.

8.9. Installation Step 8 - Shorten the length of the emergency release cord

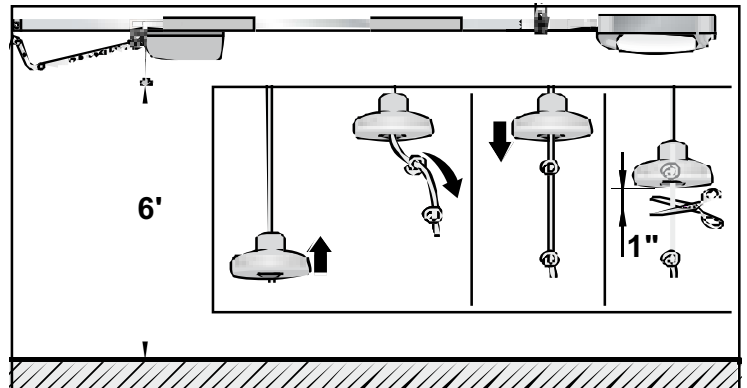

1. Determine the position of the handle.
2. Tie a knot at the desired position (dimensions see graphic).
3. Cut off the remaining cord.

8. Installation

8.10. Installation Step 9 - Set the the limit stops

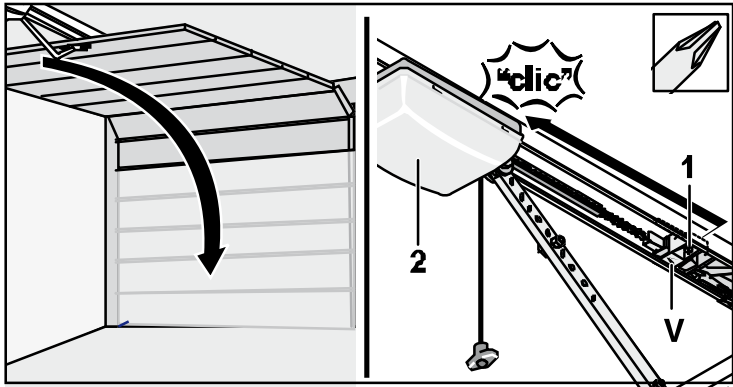

1. Close the door by hand.
2. Slide the limit stop (with the V marking) all the way to the carriage (2) until you hear a click.
3. Tighten the screw (1) with a phillips screwdriver.

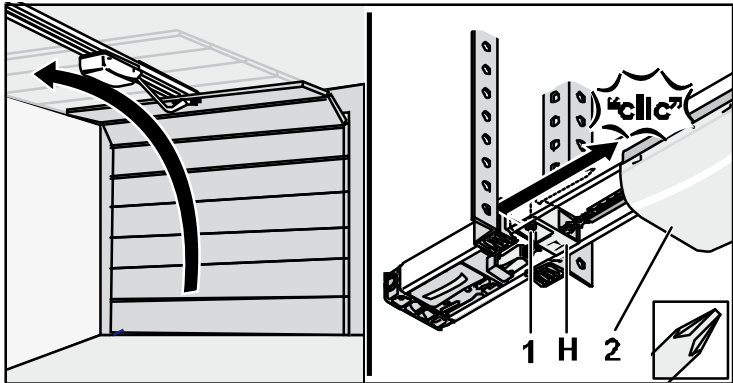

4. Open the door by hand.
5. Loosen the screw (1) on the limit stop (with the H marking) using a phillips screwdriver and slide the limit stop all the way back to the carriage (2) until you hear a click.
6. Tighten the screw (1) with a phillips screwdriver.

8.11. Installation Step 10 - Attach the Control Housing to the C-rail

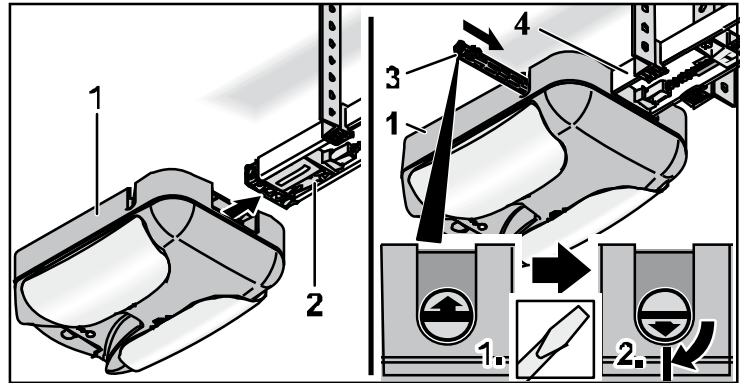

1. Make sure the contact on the slide in part (2) faces down.
2. Slide the control housing (1) all the way onto the rail.
3. Slide in the fastening bolt (3) all the way through the hole of the control housing (1).
4. Turn the fastening bolt (3) a half turn in the clockwise direction up to the stop position using a medium slotted-screwdriver (see graphic).
If a half turn is not possible, the control housing (1) is not correctly attached to the C-rail (4). Move the control housing slightly while sliding in the fastening bolts up to the stop position.
5. The electrical contact is established after connecting the control housing to the C-rail. The two contacts supply power (24V) to the motor carriage.

9. Electrical Connection

9.1. Installation Step 11 - Connect to a power outlet or to a permanent wiring connection

The opener has a grounding type plug, to reduce the risk of electrocution. This plug will only fit into a grounding type outlet. If the plug does not fit into the outlet, contact a qualified electrician to install a proper outlet. Do not modify the plug in any way. The electrical power outlet must be located within a maximum distance of 4' (1,22 m) to the control housing.

⚠ DANGER

There is a risk of injury or death through electrical voltage if you do not observe and comply with the following information. Therefore, observe and comply with all listed instructions before the electrical connection.

If a grounded 3-pole power outlet has to be installed, this should be performed only by a qualified electrician!

The opener can also be connected to the voltage supply. This permanent wiring connection may be performed only by a qualified electrician!

The valid local and national regulations must be observed for the electrical connection.

Do not use an extension cord.

Do not use an adapter to bypass the grounding (3-pole to 2-pole **non**-grounded plug). Never remove or modify the ground pin on the plug.

9.2. Power outlet connection

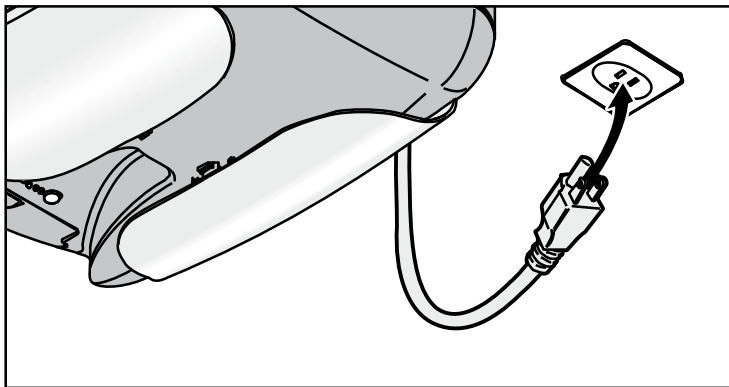

- ▀ Plug the 3-pole power plug into a grounded 3-pole power outlet

9.3. Permanent wiring connection

⚠ DANGER

There is a risk of injury or death through electrical voltage if you do not observe and comply with the following information.

The permanent wiring connection may be performed only by a qualified electrician!

The valid local and national regulations must be observed for the electrical connection.

During the installation, switch off the on-site circuit breaker or disconnect the one-site fuse for the circuit that will supply the opener with voltage.

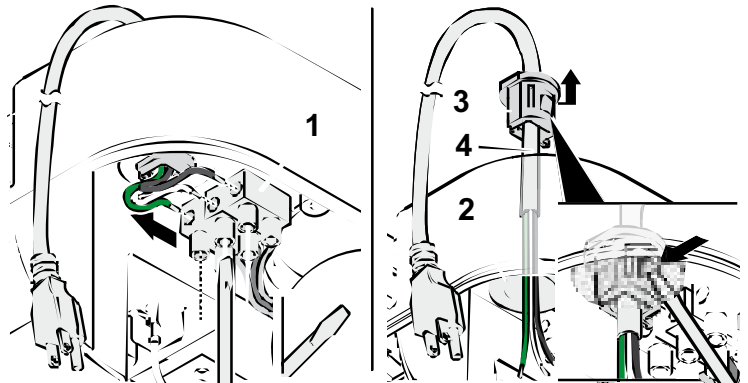

1. Loosen the three wires (N = white, hot = black, ground = green) on terminal block 1
2. Remove the strain relief bushing
3. Remove and throw away the cable and strain relief

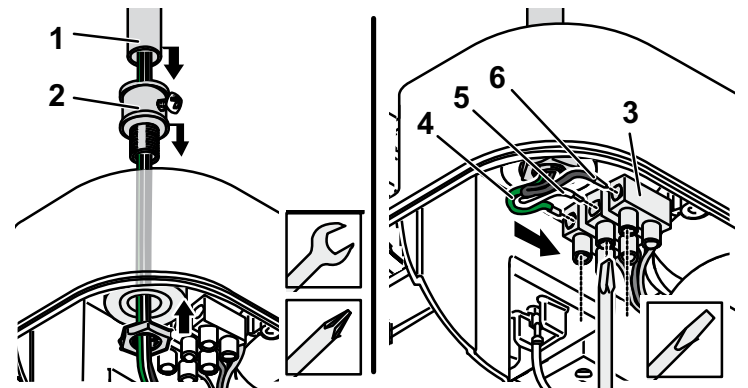

1. Run the cable from a electrical supply in a conduit
2. Install a suitable entrance bushing
3. Connect the three cables to the cable terminals
4. (N = white; Hot = black; Ground = green)

10. Photo Eyes

10.1. Installation Step 12 - Install the Photo Eyes

⚠ WARNING

There is a possible risk of injury or death through electrical voltage if you do not observe and comply with the following information.

Prior to installation, ensure that there is no voltage present to the opener.

Do only connect the photo eyes to the opener terminals in the control housing.

Some local construction ordinances do not allow an on-wall installation of wires. Please check with your local building inspector.

10.2. Function

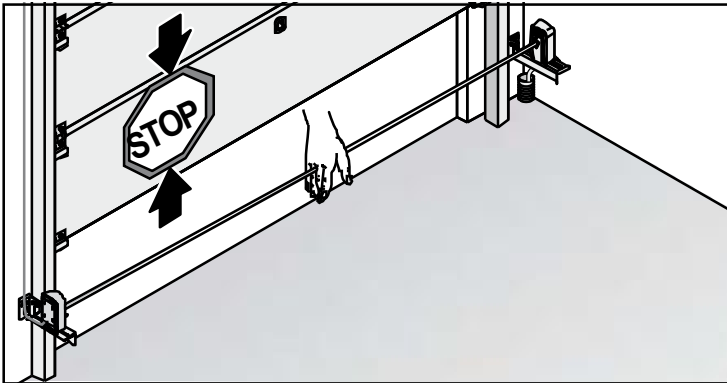

The photo eye set safeguards the door. If the photo eyes are breached, the door's closing procedure is stopped. If the door stops during closing because of the photo eyes, it subsequently opens completely.

The opener only functions with the connected photo eye set.

Scope of supply- see page 11

10.3. Installation requirements and dimensions

⚠ WARNING

There is a possible risk of injury or death if the following conditions are not fulfilled. The photo eye set may only be installed when the following installation requirements and installation dimensions are given.

Never run the photo eye wires next to an on-site power wire as this can cause malfunctions in the opener controls.

Select an installation location for the photo eyes inside the garage and outside of the range of motion of the door and the opener mechanics.

10. Photo Eyes

Top view:

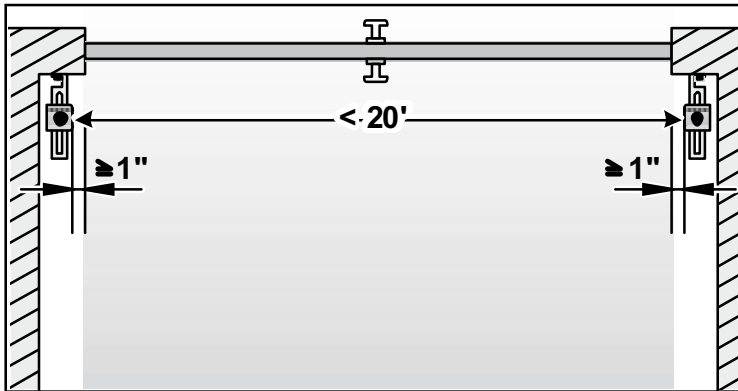

The photo eyes must be correctly connected and aligned before the garage door opener will move in the down direction.

Do not mount the photo eyes in the area of the moving garage door. Mount at least 1" (25 mm) away from it.

The distance between the transmitter and receiver of the photo eye set can range up to a maximum of 20' (6,10 m).

The distance from the floor must be selected so that an obstacle of 6" (152 mm) high can be reliably detected. This corresponds to a distance of 2" (50 mm) from the bottom edge of the installation bracket to the floor.

The photo eye set consists of a transmitter (green sticker) and a receiver (red sticker). Mount one photo eye to the left and one to the right of the door. As a general rule, it does not matter which photo eye is installed on the left or on the right side.

If the photo eyes are exposed to direct sunlight, the receiver (red sticker) should be installed on the side facing away from the sun.

For garages with multiple doors (top view)

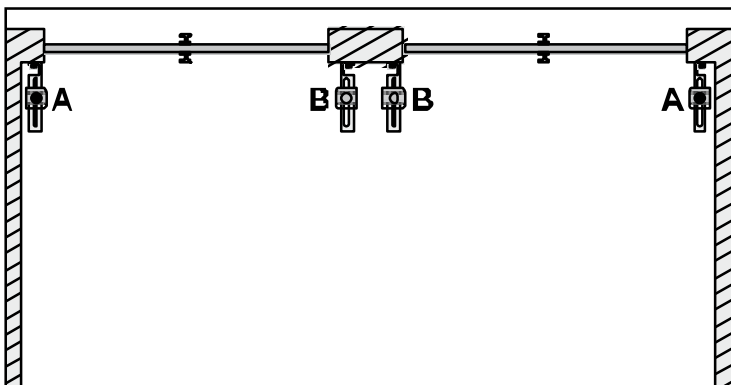

Install the photo eyes as shown in the diagram. A = receiver (red sticker), B = transmitter (green sticker). On this way the photo eyes cannot influence each other through stray light.

10.4. Installation

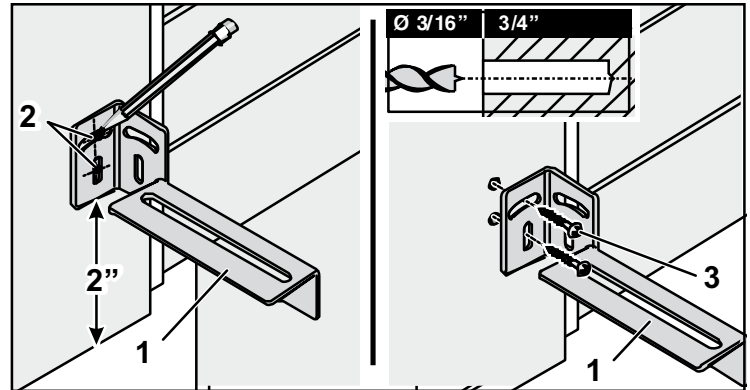

1. Look for a suitable installation position for the mounting bracket (1) inside the garage to the left and the right of the door.
2. Hold the mounting bracket (1) to the wall and mark the mounting points. The distance from the bottom edge of the installation bracket to the floor is 2" (50 mm). The height and angle of the bracket can be adjusted through the slotted holes (2).

⚠ Warning

Risk of injury from flying chips when drilling. Drilling chips can get into the eyes and cause injury.

Always wear safety glasses when drilling.

3. Drill holes for the plywood screws (3).
4. Screw in two plywood screws 6 x 40 mm (3).

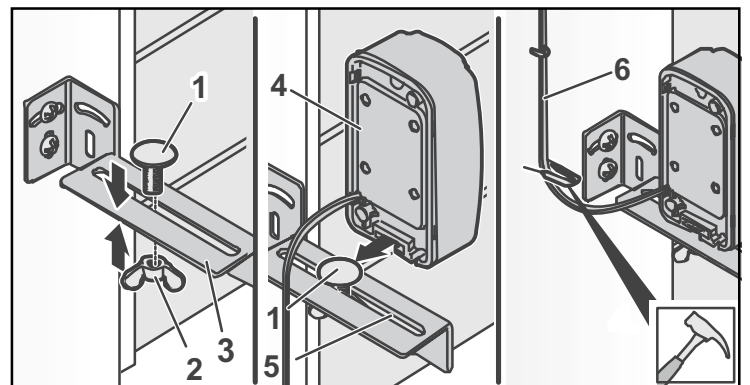

5. Pre-attach the carriage bolt M6 (1) and the wing nut M6 (2) to the mounting bracket (3).

10. Photo Eyes

- Slide the transmitter (4) over the head of the carriage bolt M6 (1) and tighten the wing nut M6 (2). The position of the photo eyes can be adjusted through the slotted holes (5).
- Mount the receiver on the opposite side in the same way.
- Run the two sets of wires (6) from the photo eyes to the control housing.
- Use staples to keep wires in place.

10.5. Connection

Connect photo eyes to the control housing

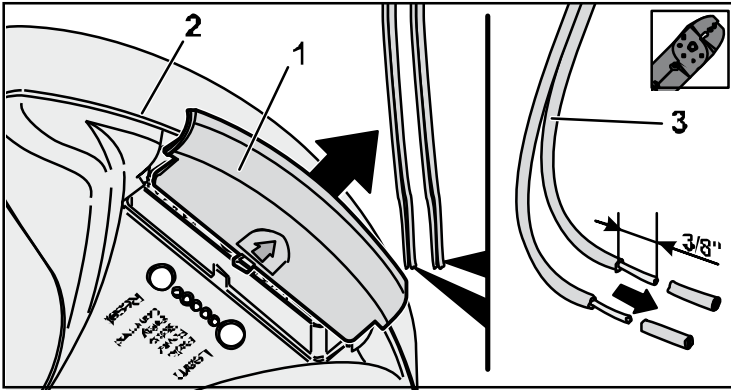

- Remove the red cover (1) of the control housing (2).
- Strip off insulation approx. 3/8" (10 mm) from the wire ends (transmitter and receiver).

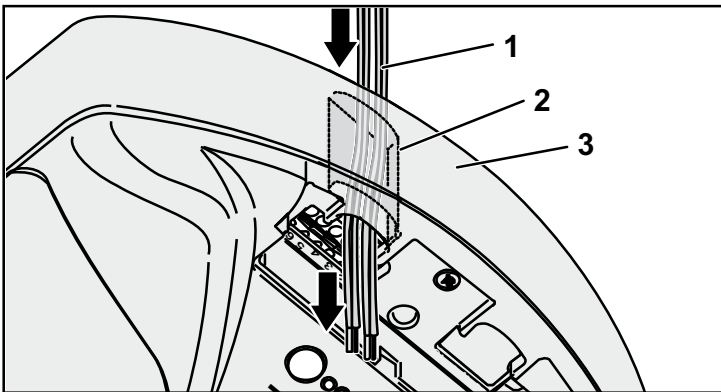

- Guide both sets of wires (1) from the outside through the opening (2) into the control housing (3).

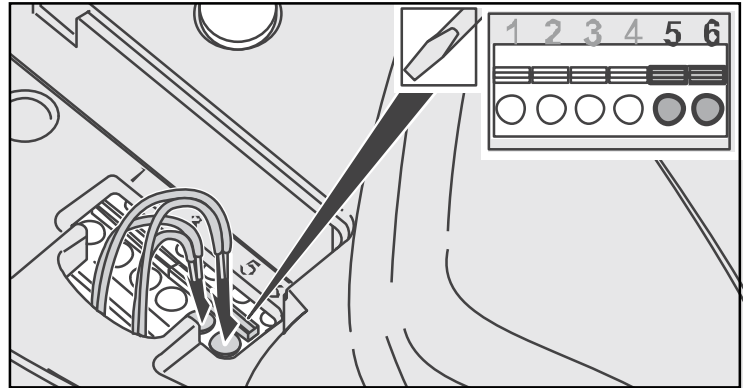

- Connect one wire of the transmitter to terminal 5 and the other wire to terminal 6.
- Connect one wire of the receiver to terminal 5 and the other wire to terminal 6.

Note

If you have inadvertently inserted a wire end incorrectly, you can open the terminal using a small slotted screwdriver (press down) and pull out the wire end.

11. Wall Station

11.1. Installation Step 13 - Install the Wall Station

⚠ WARNING

There is a possible risk of injury or death through electrical voltage if you do not observe and comply with the following information.

Prior to the installation, ensure that there is no voltage present at the opener.

Only connect the wall station to the connection provided at the opener (see the following description).

Ensure that there are no voltage-carrying wires that could be drilled into.

Some local construction ordinances do not allow an on-wall installation of wires. Please check with your local building inspector.

11.2. Functions

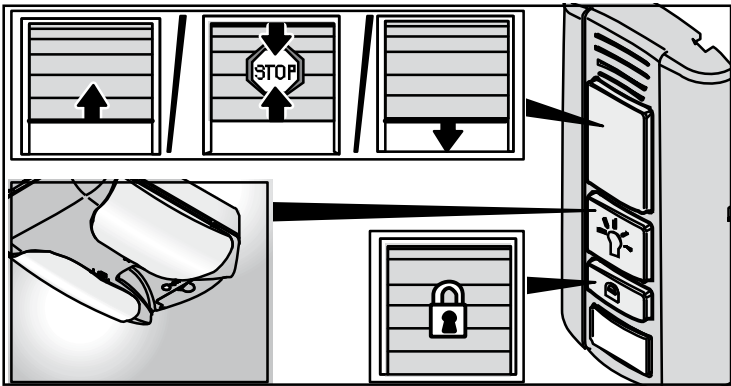

You can control the following functions of the opener with the wall station:

- Opening, stopping or closing the door
- Turning the light on or off
- Lock or unlock the opener

11.3. Installation requirements and dimensions

⚠ WARNING

There is a possible risk of injury or death if the following conditions are not fulfilled. The wall station may only be installed if the following installation requirements and installation dimensions are given.

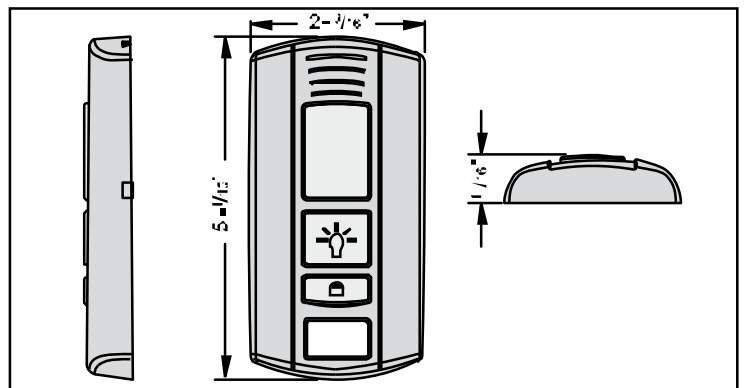

Scope of supply- see page 12

Never run the wires between the wall station and the opener along an on-site power wire as this can cause malfunctions in the opener controls.

Choose an easily accessible location in the garage for the wall station installation.

The distance to the floor must be at least 5' (1.50 m) so that children cannot reach the wall station.

Select the mounting location:

- outside of the range of motion of the door and opener mechanics
- so the user can see the door directly
- when operating the wall station, the user can remain outside of the range of motion of the door and opener mechanics
- on a flat surface

11. Wall Station

11.4. Installation and connection

The wall station is generally mounted directly to the wall. Using the supplied mounting screws, it can be mounted to wooden or drywall substrates. If the supplied wires have previously be run under the wall surface, it can also be mounted to an empty electrical box.

Connection in the wall station

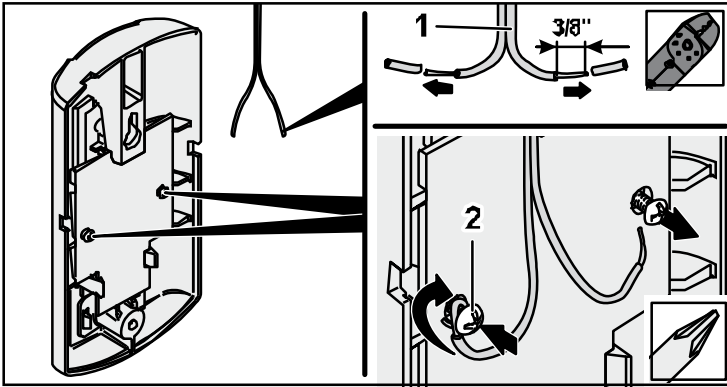

1. Strip off approx. 3/8" (10 mm) of insulation from the wire ends.
2. Unscrew the screws 1/8" x 3/8" (2) so that the wire ends can be wrapped around.
3. Wrap both stripped wire ends around the screws (2). It does not matter which wire is wrapped around which screw (polarity-proof connection).
4. Tighten both screws 1/8" x 3/8" (2) and check if the wire ends are held firmly.

Mounting to a wall

1. Select and mark the upper mounting point.
2. Insert the screw 1/8" x 1.2" (1) far enough (approx. 1/8") so the housing (2) will hang on the wall.
3. For drywall installation using drill with a 3/16" masonry bit, drill two holes and insert two anchors 3/16" (1).
4. Run the cable through one of the holes, located on the sides or the top of the housing.

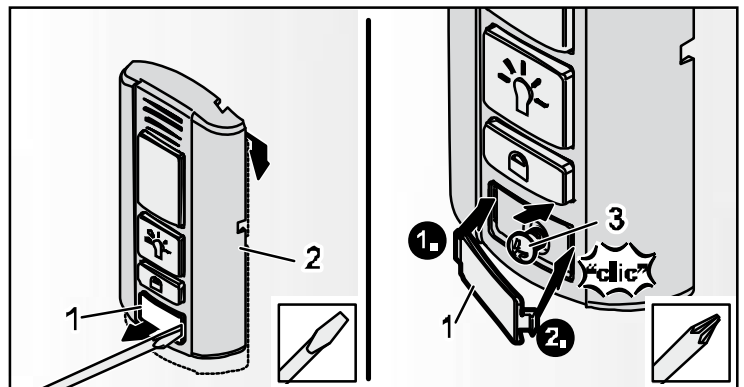
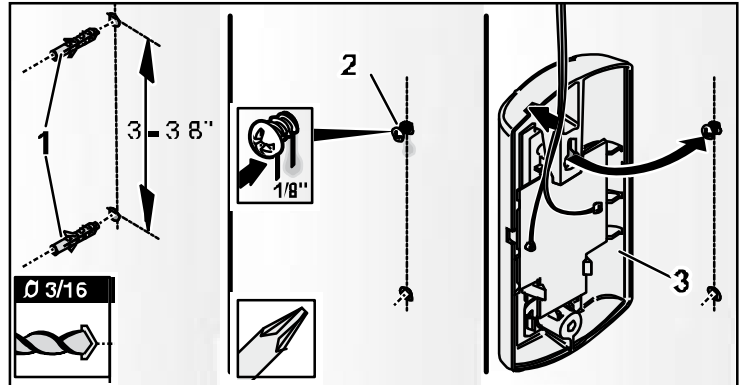

5. Clip out the cover (1) with a small screwdriver or by pushing it out from the backside.
6. Hang the housing (2) upright and mark the lower mounting point.
7. Screw in the screw 1/8" x 1.2" (3).
8. Fit the covering in on the left side (1) and click it in on the right side (2).

11. Wall Station

Mounting to a electrical box

⚠ WARNING

There is a possible risk of injury or death through electrical voltage if you install the wall station in an electrical box.

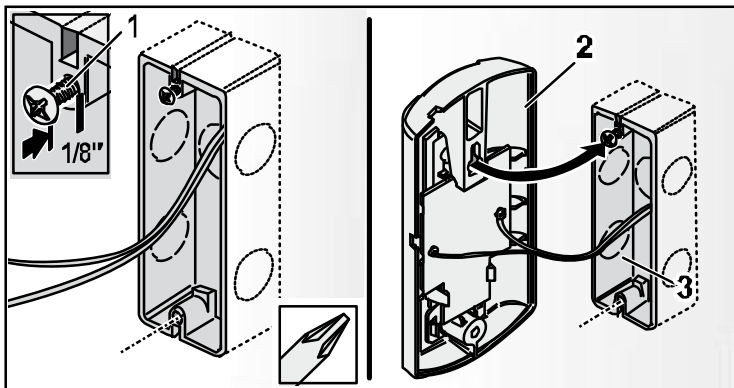

1. Insert the screw 1/8" x 1.2" (1) far enough (approx. 1/8") so the housing (2) will hang on the wall.

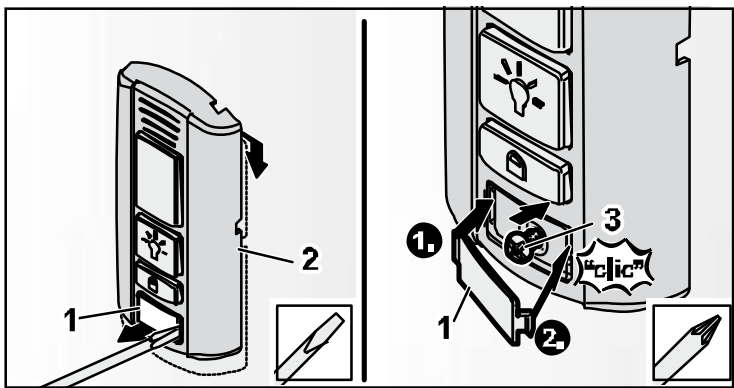

2. Clip out the cover (1) with a small screwdriver or by pushing it out from the backside.
3. Hang the housing (2) and attach it with the 6/32 x 1" screws (3).
4. Fit the covering in on the left side (1) and click it in on the right side (2).

Connect to the wall station to the control housing

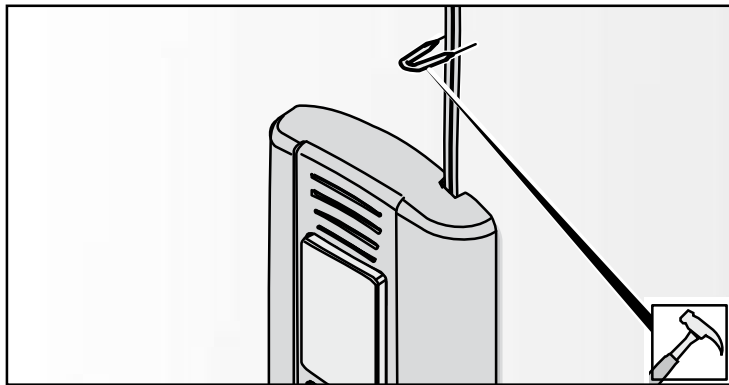

1. Run the wire from the wall station to the control housing and secure with suitable material (i.e. staples).

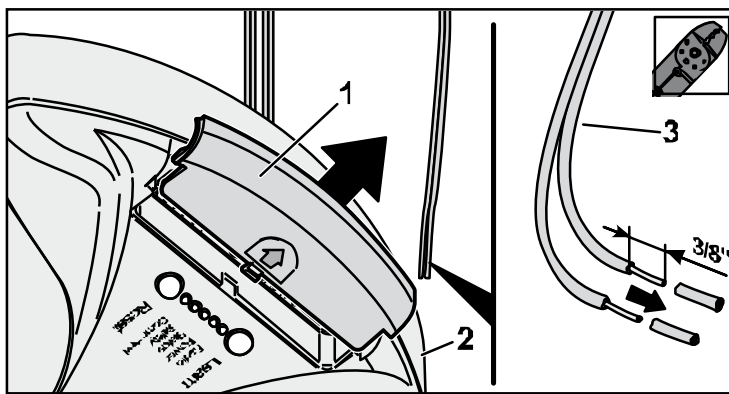

2. Shorten the wire to the required length.
3. Strip off approx. 3/8" (10 mm) of insulation.

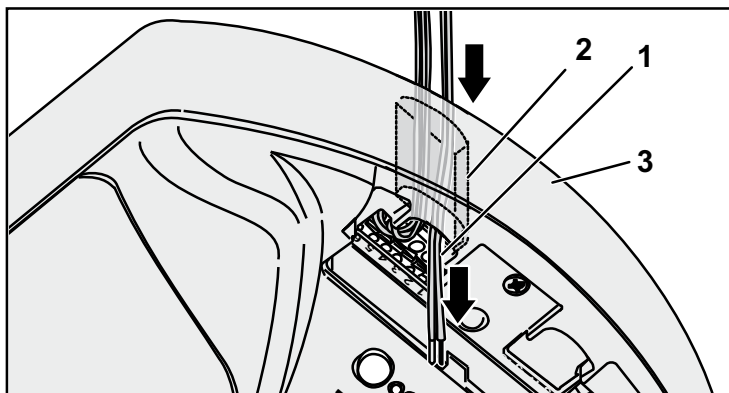

4. Guide the wires (1) from the outside through the opening (2) in the control housing (3).

11. Wall Station

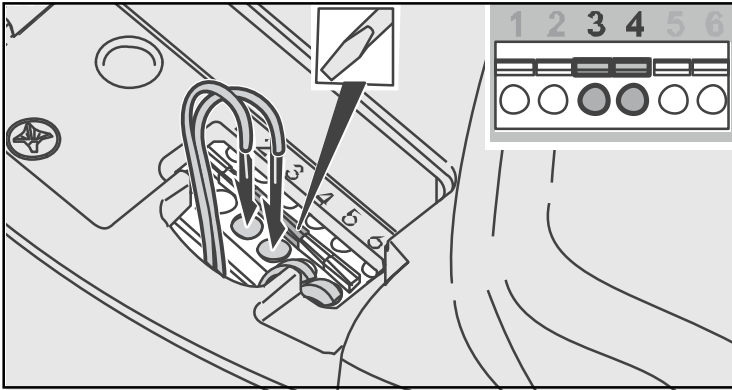

5. Insert each of the wires to **terminals 3 + 4**.
It does not matter which cable goes into which terminal (polarity-proof terminal assignment).
If you have inadvertently inserted a wire end incorrectly, you can open the terminal using a small slotted screw-driver (press down) and pull out the wire end.

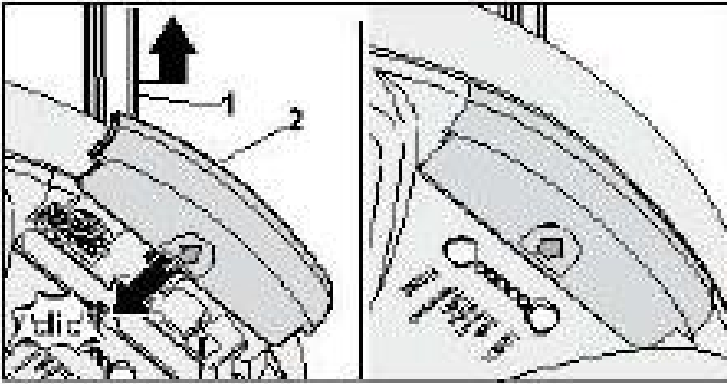

6. Carefully pull on the wires (1) from the outside so the wires are tight and the cover (2) can be closed.

12. Initial operation

⚠ WARNING

There is a possible risk of injury or death if a person remains within the area of the door's running path when using for the first time.

As long as the door is in motion, it should remain visible to the user and remain clear of other people or objects. Do not allow anyone to remain within the area of motion of the door.

12.1. Installation Step 14 - Installing light bulbs

⚠ WARNING

There is a risk of injury or death through electrical voltage if you accidentally reach into the lamp socket when the opener is powered on.

Only restore the power supply when specifically instructed in this manual.

CAUTION

There is a risk that the opener can be damaged or catch fire if you use different light bulbs than approved.

Use only light bulbs as specified in this manual.

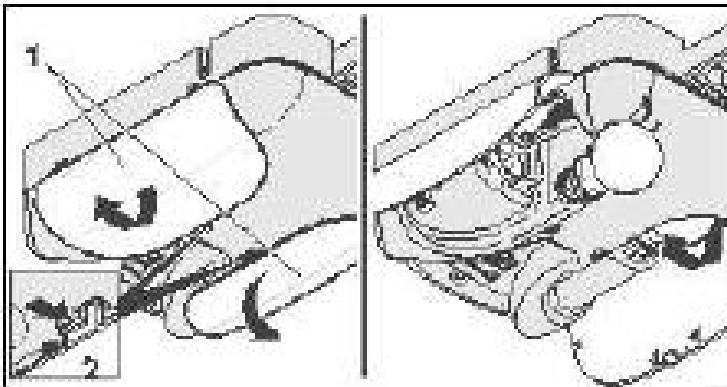

1. Open both of the lamp covers (1).
2. Insert light bulbs in each of the sockets (maximum 60 W, standard bulb, Ø 2"/51 mm) in clockwise direction.

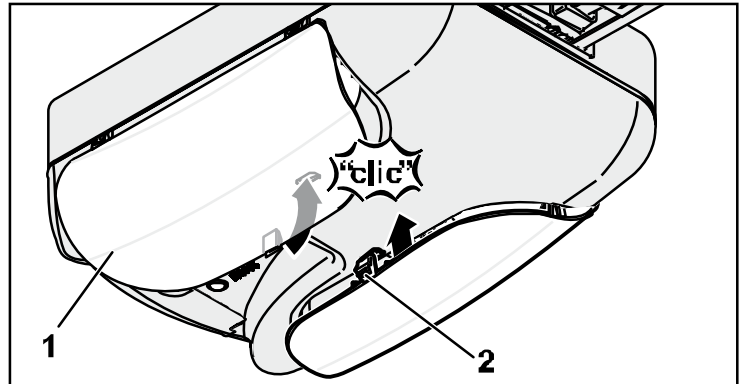

3. Close both lamp covers (1), the latch must (2) snap into place.

12.2. Installation Step 15 - Program the transmitter

In order to open, close or stop the opener using the transmitter, the opener has to "learn" the code first. The radio code of the transmitter is transmitted to the receiver (inside the control housing).

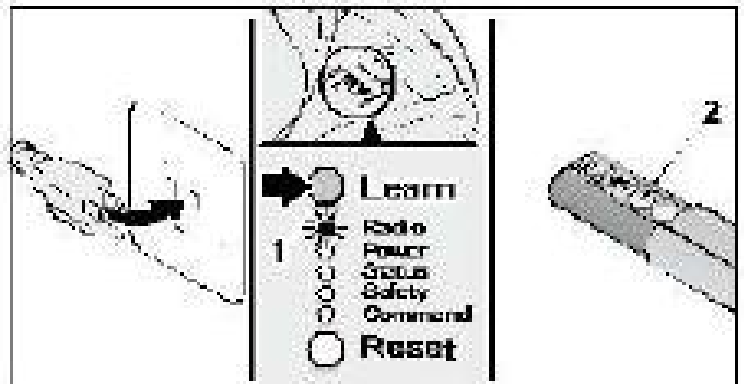

1. Plug in the power plug into the power outlet
or
2. Switch on the electrical supply for a permanent wiring connection (switch on the circuit breaker or fuse).

12. Initial operation

Learning the radio code

1. Press the learn button (1) once on the control housing.
 - ⇒ The LED (Radio) is solid.
2. Press a desired transmitter button (2).
The LED (Radio) flashes briefly.
 - ⇒ If the LED (Radio) lights up for a second, the transmitter has been learned.

Programming additional transmitters. Repeat the above steps. A maximum of 20 button/storage locations for each radio receiver are available.

If no radio code is received within 10 seconds, the learning process is interrupted and has to be started again if necessary.

Light function

In order to switch the light on the opener on or off separately using the transmitter, a second transmitter button function has to be "learned in".

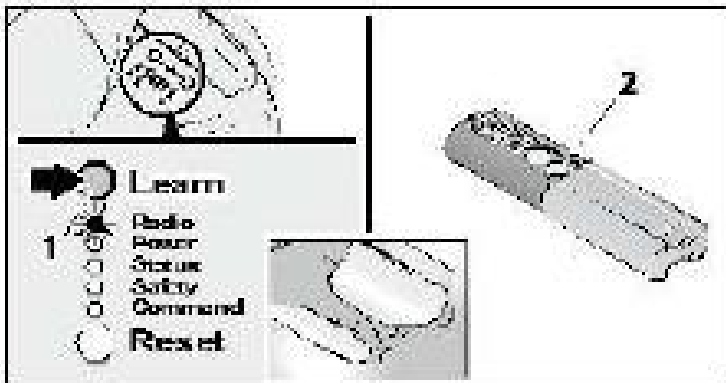

1. Press the learn button (1) on the control housing two times. The LED (Radio) blinks briefly.
2. Press the desired transmitter button (2).
 - ⇒ When the LED (Radio) lights up for a second, the transmitter has been learned.

Other functions

Depending on the DIP switch settings, other functions such as "partial opening" or "defined operation" can be "learned in" for a second transmitter button in the same way. See chapter "Settings".

Deleting a previously learned radio code

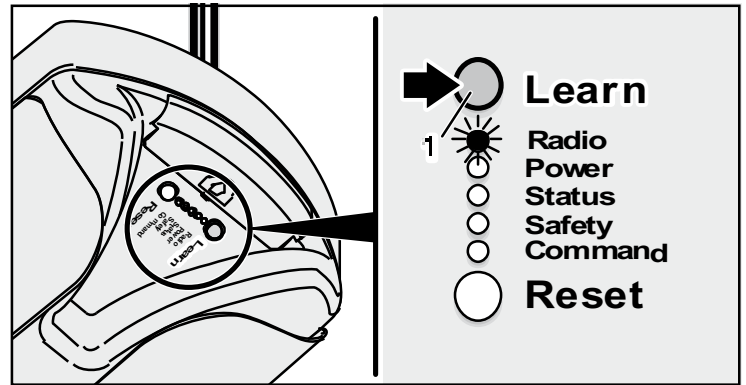

1. Press the learn button (1) on the control housing for at least five seconds until the LED (Radio) blinks slowly.
2. Press the desired transmitter button. The LED (Radio) lights up for one second.
 - ⇒ When the LED (Radio) turns off, the radio code of this transmitter button is deleted.

12. Initial operation

Deleting all previously learned radio codes

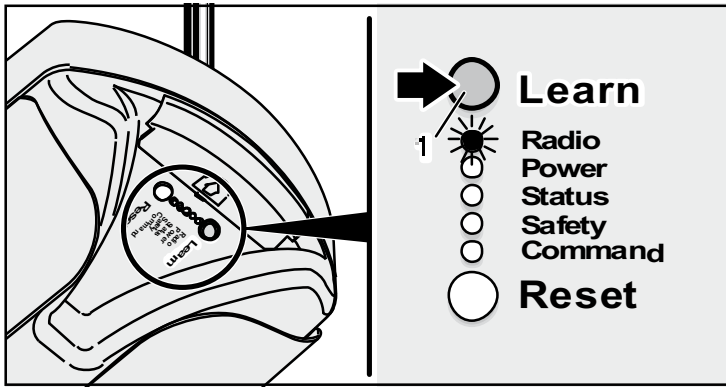

- ▶ Press the learn button (1) and hold for approx. 60 sec. until the LED (Radio) turns off.
 - ▣ All radio codes have been deleted.

Adjusting the photo eyes

If the LED in the photo eye transmitter lights up continuously green and the LED in the receiver lights up red, the photo eyes are set correctly. Only the functioning must now be subsequently checked, please see "Testing the photo eyes function" (page 37).

If both LEDs do not light up continuously, the photo eyes have to be adjusted as follows:

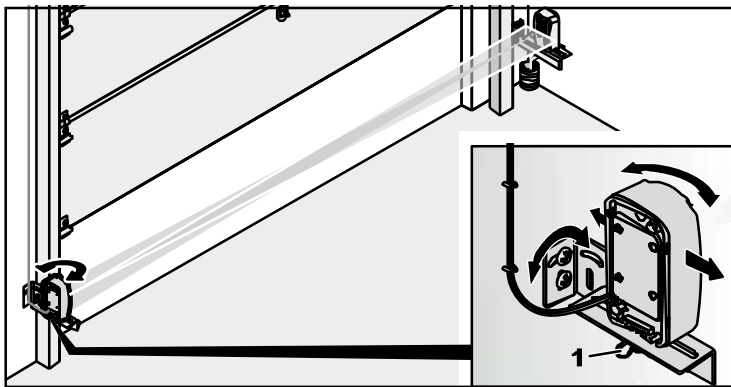

- ▶ Loosen the wing nut (1) either on the transmitter or the receiver and adjust the position until both LEDs light up continuously. By loosening the screw (2), the adjustment angle can also be changed.

Please test the proper function, see "Test the photo eyes function".

12.3. Learning the forces of the door

When the opener is initially connected to the main supply, the opener lights blink. This indicates that the opener is ready to learn the forces of the door.

After the completion of two full cycles (four door movements) the lights will stop blinking. The opener controller automatically detects the required force each time the door moves. If an obstacle (i.e. a person or a vehicle) blocks the door's movement,

- in the closing direction: the door will reverse automatically.
- in the opening direction: the door will stop.

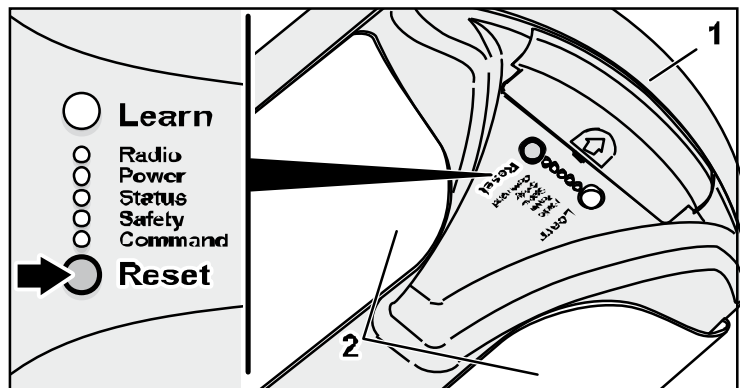

1. Press the Reset button on the control housing (1) until the "Status" LED turns off. The LED "Status" blinks while being pressed.
2. Release the Reset button.
 - ⇒ The light (2) and the LED "Status" blink.

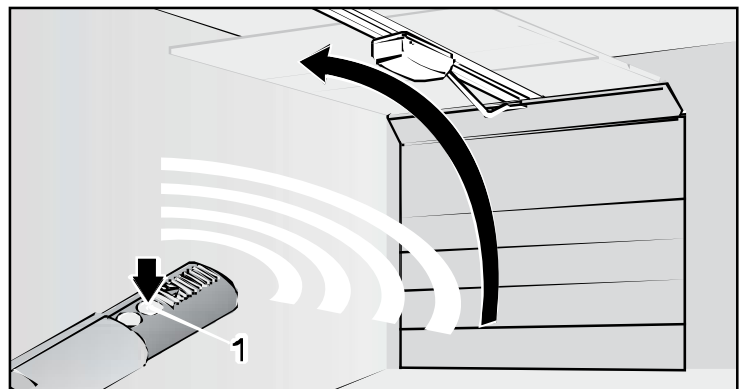

3. Operate the door two full cycles
 - ▣ The light stays on. The learning process is completed.
 - ▣ The light will turn off after approx. 180 seconds.

12. Initial operation

12.4. Test the emergency release

⚠ WARNING

There is a possible risk of injury or death if the emergency release is triggered with an open door.

The emergency release should preferably be used when the door is closed. It should only be used with caution when the door is opened. Weak or broken springs can cause the door to close surprisingly quick and could increase the risk of serious injury or death.

1. Close the door.

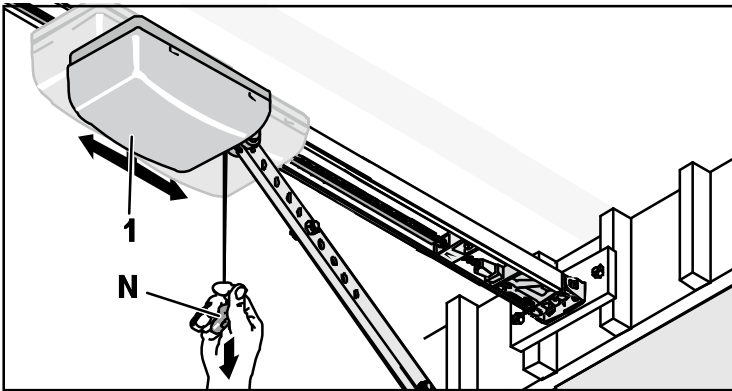

2. Pull on the emergency release cord handle (N) once.
 - When functioning correctly, the carriage (1) is now unlocked and the door can now be moved by hand.

12.5. Test the obstacle detection function

⚠ DANGER

There is a possible risk of injury or death if the obstacle detection is not working.

Persons could get squeezed, jammed or pinched by a closing door that does not stop after it has encountered an obstacle.

After the force has been learned, the obstacle detection must be checked.

The door must change directions after contacting a 1" (25,4 mm) high object on the floor.

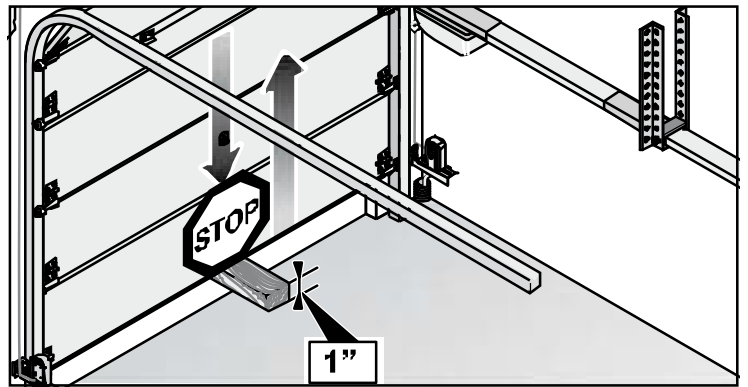

1. Open the door with the opener.
2. Place an 1" (25.4 mm) object centered in the running path of the door.
3. Close the door with the opener.

When the door contacts the object, it must stop immediately and reverse completely.

If the door does not reverse, check the basic settings of the limit stop, see chapter "Installation". In all other cases, the opener is defective and must be repaired or replaced. Consult your qualified dealer for advice.

12. Initial operation

12.6. Test the photo eyes function

1. Close the door with the opener.

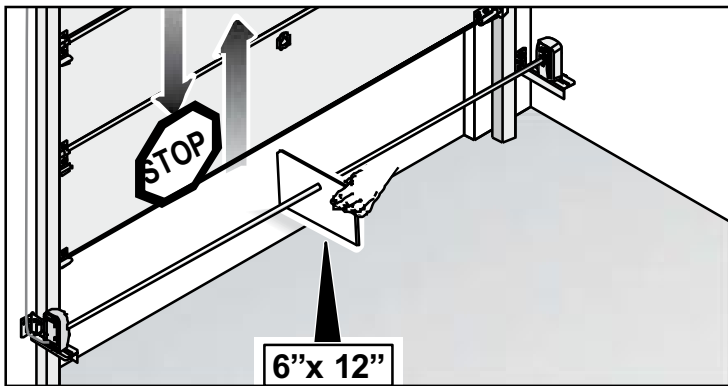

2. Hold a 6" high white object during the closing procedure in between the photo eyes to disrupt the infrared beam. The door must stop immediately and then reverse entirely.

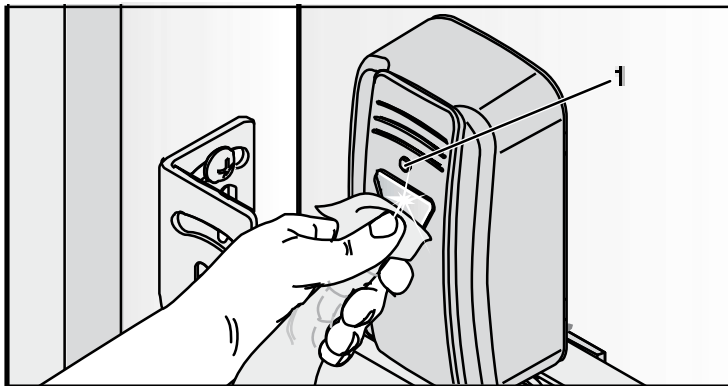

■ The photo eyes are functioning properly, if the LED lights of both photo eyes are solid

3. If the door does not stop, check the following:
 - if the housing of the photo eyes are dirty,
 - whether transmitter and receiver are correctly aligned with each other,
 - whether the cables are damaged or loose.

12.7. Attach the warning labels

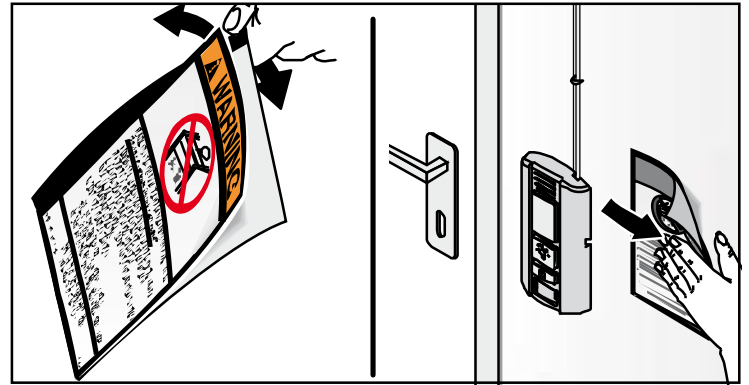

1. Attach the warning labels in an visible area of the garage (for example near the wall station).

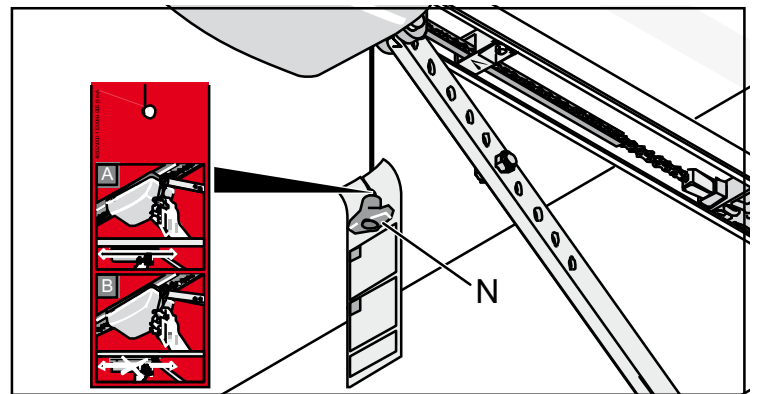

2. Attach the hanging warning sign to the emergency release cord (N).

13. Operation

Important safety instructions

⚠ WARNING

WARNING – to reduce the risk of severe injury or death:

1. READ AND FOLLOW ALL INSTRUCTIONS.
2. Never let children operate or play with door controls. Keep the remote control away from children.
3. Always keep the moving door in sight and away from people and objects until it is completely closed. **NO ONE SHOULD CROSS THE PATH OF THE MOVING DOOR.**
4. NEVER WALK UNDER A STOPPED OR A PARTIALLY OPENED DOOR.
5. Test door opener monthly. The garage door should reverse on contact with a 1-1/2-inch high object laid flat on the floor. After making any adjustments, re-test the door opener. Failure to test the opener properly increases the risk of severe injury or death.
6. If you need to use the emergency release the door should be in the closed position. Use caution when using the release while the door is open. Weak or broken springs are capable of increasing the rate of door closure and increasing the risk of severe injury or death.
7. KEEP GARAGE DOORS PROPERLY BALANCED. See owner's manual. An improperly balanced door increases the risk of severe injury or death. Have a qualified dealer perform repairs to cables, spring assemblies, and other hardware.
8. **SAVE THESE INSTRUCTIONS.**

⚠ WARNING

There is a possible risk of injury or death if you do not observe and comply with the following information. Observe and comply with all listed instructions before operating.

Only operate the transmitter when you have direct line of sight to the door and no persons or objects are located in the area of the door's motion.

Only pass through the garage opening after the garage door has opened completely.

Store the transmitter in a safe place to prevent unwanted operation for example, by children.

Do not use the transmitter in areas with sensitive radio communications or systems (for example: airports, hospitals).

13.1. Lights

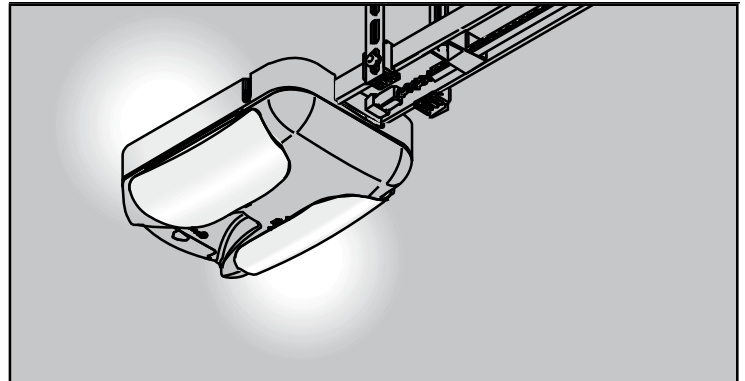

The integrated light switches on automatically when the opener is operated. It can also be switched on using the transmitter or via the wall station without the opener being in operation.

13.2. Operating the opener with the transmitter

The transmitter has a range up to 100 ft (30 m) depending on the surrounding area.

13. Operation

Opening, closing, and stopping the door

In order to operate the opener using the transmitter, this opener function first has to “learn in” the code of a particular transmitter. See “Program the transmitter”.

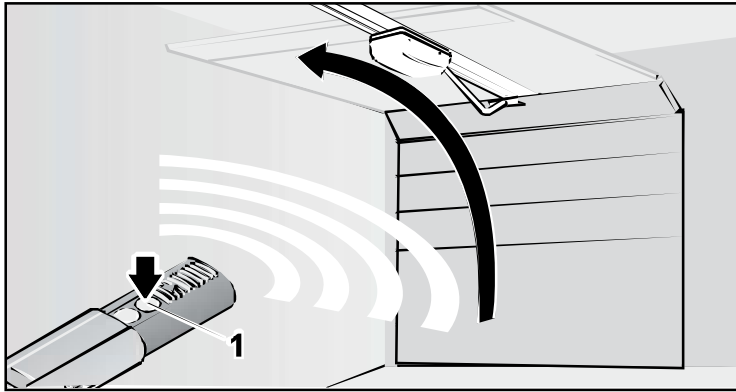

1. To open and close the door, press the corresponding button on the transmitter one time (e.g. button 1). Depending on the starting position, the door either opens or closes.
 - ⇒ The light switches off automatically after 180 seconds.
2. To stop the door, press the corresponding transmitter button during the open/close procedure. Pressing the transmitter button again causes the door to move back to its respective starting position.

Turning the light on or off

In order to be able to switch the light on the opener on or off separately using the transmitter, a second transmitter button has to be “learned in” and assigned to this function. See “Programming the transmitter”.

1. Press the corresponding transmitter button once to switch the light on.
 - The light is switched on and switches off automatically after 180 seconds.
2. Press the corresponding transmitter button once to switch the light off. If the light was automatically switched on during the opener movement, it can only be switched off after the opener movement has completed.

13.3. Operating the opener with the wall station

Opening, closing, and stopping the door

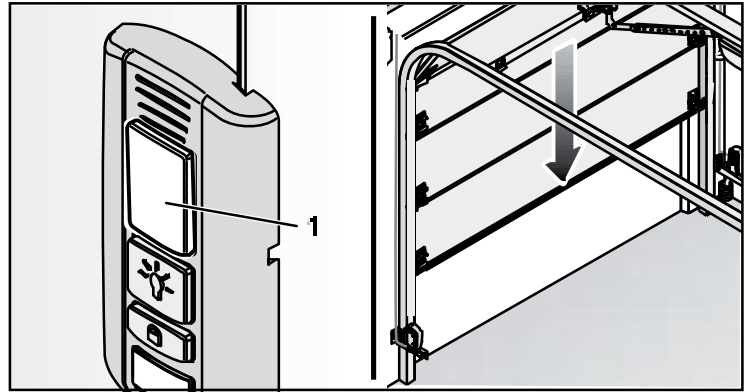

1. To open and close, press the button (1) once. The door opens or closes depending on the starting position.
 - The light switches off automatically after 180 seconds.

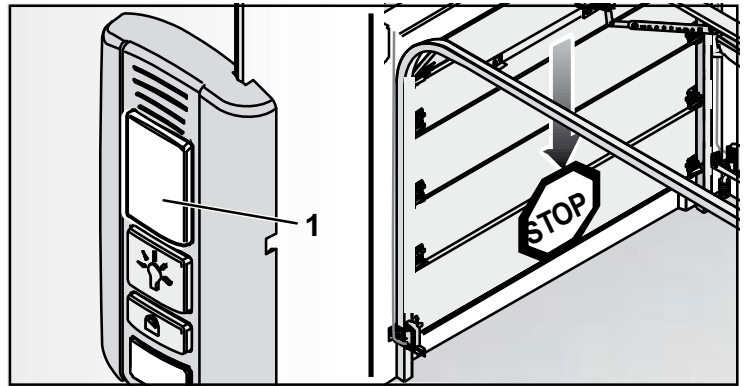

2. To stop, press the button (1) during the open/close procedure once. The next press of the button (1) causes the door to move back to its respective position.

13. Operation

Turning the light on or off

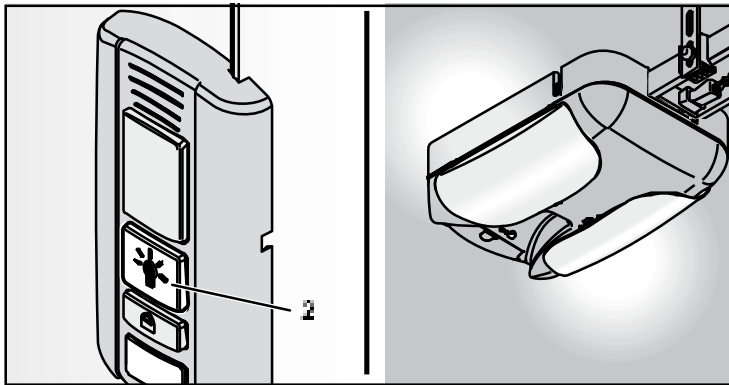

3. Press the corresponding button (2) once to turn the light on.
 - ⇒ The light switches off automatically after 180 seconds.
4. To turn the light off, press the button (2) once. If the lighting was automatically turned on because of the opener movement, it can only be turned off after the opener movement has completed.

Lock or unlock the opener

The opener can be locked to prevent from being unwanted operation during longer periods of absence (i.e. travel/ vacation).

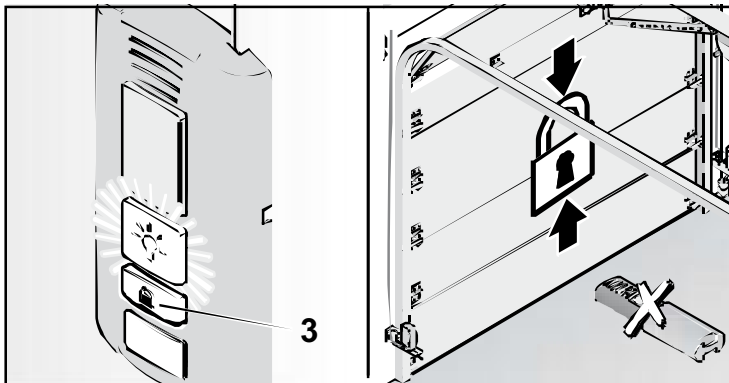

1. To lock the opener, press and hold the button (3) (at least 8 seconds) when door is closed, until the green light changes to red. All opener functions are now locked. If the door is open during the locking procedure, it can still be closed by using the transmitter/ keypad. After that all opener functions are locked.
2. To unlock the opener, press and hold the button (3) (at least 8 seconds), until the red light changes to green. All functions of the opener are now unlocked and active.

13.4. Emergency release from the inside

In the event of a power failure, the door can be opened from the inside using a mechanical emergency release.

⚠ WARNING

There is a possible risk of injury or death if the emergency release is triggered with an open door.

The emergency release should preferably be used when the door is closed. It should only be used with caution when the door is opened. Weak or broken springs can cause the door to close surprisingly and quick and could increase the risk of serious injury or death.

Disengaging the emergency release

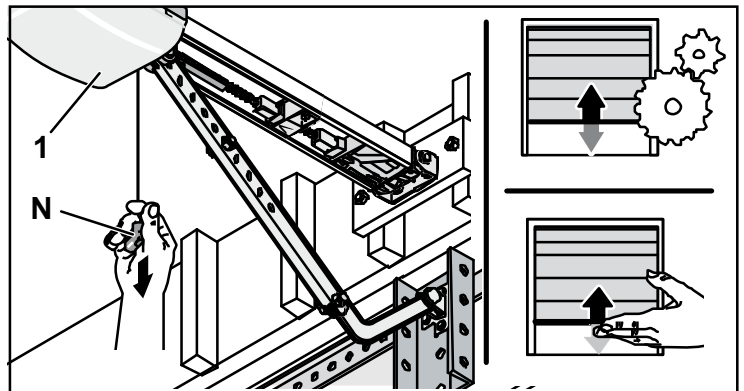

- ▀ Pull once on the handle of the emergency release cord (N).
 - ▀ The carriage (1) is unlocked and the door can be moved by hand.

Engaging the emergency release

- ▀ Pull on the emergency release cord handle (N) once.
 - ▀ The carriage (1) is now engaged and the door can only be moved by the opener.

13. Operation

13.5. Indicator lights on the control housing

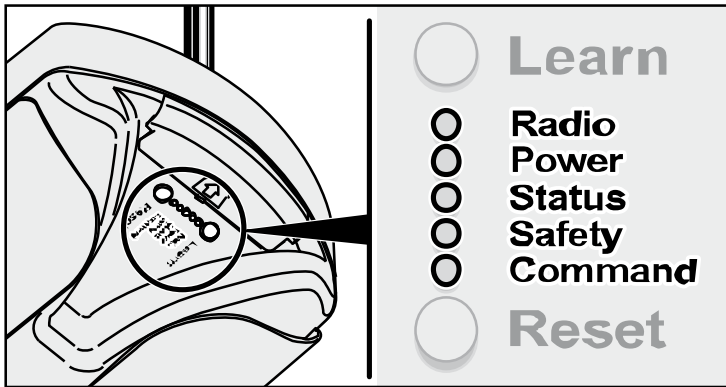

Description	Signal	Function
Radio	Red (LED)	Lights up or blinks during “learning” of a transmitter respective of the programming state. Please see “Programming the transmitter”. Lights up, as long as a transmitter button for starting the opener is pressed.
Power	Red (LED)	Lights up when the opener is supplied with voltage.
Status	Red (LED)	Always blinks while the opener opens/closes the door. If the opener is not yet learned in, the LED also blinks when the opener is in the stopped state. During the learned in state, the LED is off when the opener is in the stopped state.
Safety	Red (LED)	Lights up if the photo eyes are interrupted. As long as a correct signal is coming from the photo eyes, the LED is off.
Command	Red (LED)	Lights up if the operator is started via a transmitter or a wall station (accessory) for example.

13.6. Resetting the values/ forces

All learned values/ forces can be reset (i.e. after installing opener on a different door).

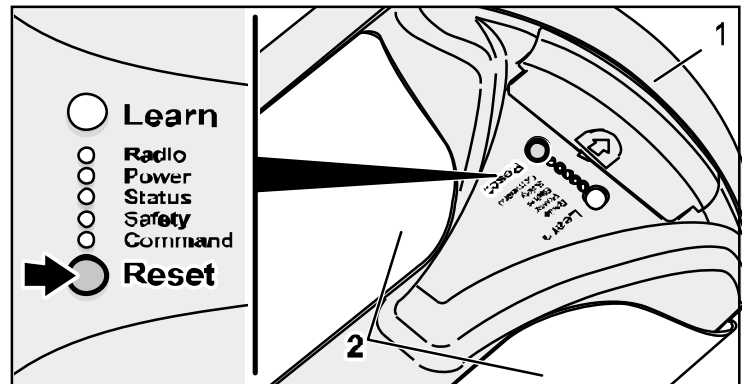

1. Press the Reset button on the control housing (1) until the “Status” LED turns off.
 - During pressing, the “Status” LED blinks.
2. Release the Reset button.
 - The light (2) and the “Status” LED will blink after the force is reset.

The operator must subsequently be released, see chapter Using for the first time “Program the opener”.

14. Settings

14.1. Overview of special functions

You can set these functions using the DIP switches, see following section.

Function	DIP switches	Function for "OFF" setting (factorysetting)	Function for "ON" setting
Soft running for "soft" opening and closing of the door.	1	The opener always starts with the soft running speed from the "Door OPEN" and "Door CLOSE" end positions. It accelerates to the maximum speed and before reaching the end position, it reduces the speed again to the soft running speed. A soft and quiet opening and closing is thus possible.	The opener moves with constant speed between the end points/ limit stops.
Backjump for relieving the door and operator mechanics when closing the door.	2	When closing the door, the operator moves to the defined end position over the limit stop and stops. It subsequently moves slightly in the "Door OPEN" direction to relieve the opener mechanics of stress.	The opener moves to the defined end position over the limit stop and stops
Defined opening and closing.	3	Switched off.	To be able to use this function, two transmitter buttons for opening/closing have to have been programmed. See chapter "Program the transmitter". Button assignment example: <ul style="list-style-type: none"> — Button 1: the door opens. — Button 2: the door closes. The lighting can now no longer be switched on/off via button 2 of the transmitter.
Partial opening for partially opening the door (for example for air circulation in the garage or with sectional doors for example for an entry for people or for accessing a bicycle). Caution: If the DIP switch 4 is set to "ON" then DIP switch 3 is automatically deactivated.	4	To partial opening, the opener opens/closes the door completely.	To be able to use this function, two transmitter buttons for opening/closing have to have been programmed. See chapter "Program the transmitter". Button assignment example: Button 1 for normal operation: the door opens/closes completely (independent of the starting position). Button 2 for partial opening operation: the door opens partially (must be set. See "Setting position for partial opening"). Subsequently open the door completely with button 1 to again close it with button 1 or 2. The lighting can now no longer be switched on/off via button 2 of the transmitter.

14. Settings

14.2. Setting the DIP switches

You can set up special functions via the DIP switches. By default, all DIP switches are set to "OFF". The power supply must be switched off during the setup.

1. Disconnect the opener from the power (switch off the circuit breaker to the opener or disconnect the fuse) and check to make sure no voltage is present.

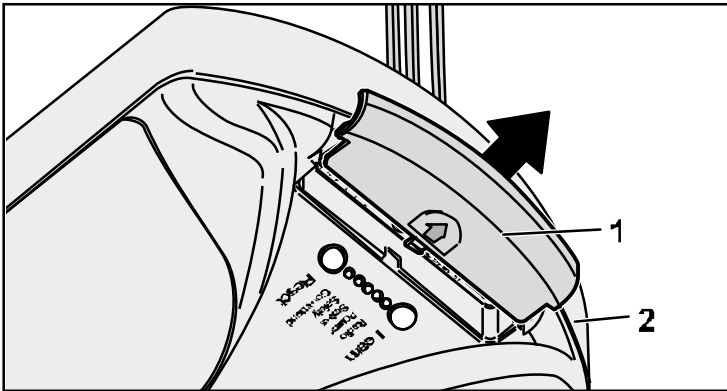

2. To set the DIP switches, slide off the red cover (1) from the control housing (2).

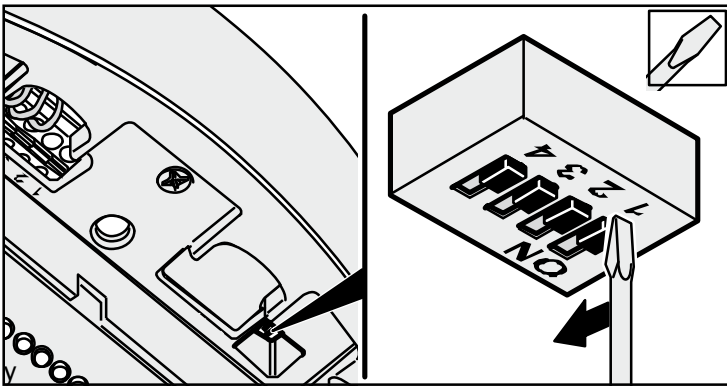

The DIP switches can be set by using a small screwdriver.

3. After setting the DIP switches, slide the red cover onto the control housing.
 4. Plug the power plug back into the power outlet
- or
5. Switch on the electrical supply for a direct electrical connection (switch on the circuit breaker or fuse).

Setting the position for partial opening

You can set the position where the door stops using the "partial open" function.

1. Close the door with the opener.
2. Set the DIP switch #4 to the "ON" position.
3. Press the learn button on the control housing twice.
⇒ Radio LED blinks.
4. Press the desired button on the transmitter (i.e. second button) that you want to use for partial opening.
5. Press desired button (#2) to open door.
6. When door reaches desired position, press button (#2) again to stop door in desired partial opening position.
7. Press the button (#2) again. The door closes.
The position for the partial opening is saved and remains stored as long as the DIP switch 4 is set to the "ON" position.

Deleting the setting:

- Set the DIP switch #4 to "OFF". The setting is permanently deleted and must be set again if needed (using DIP switch no. 4 to "ON").

15. Terminal Connections

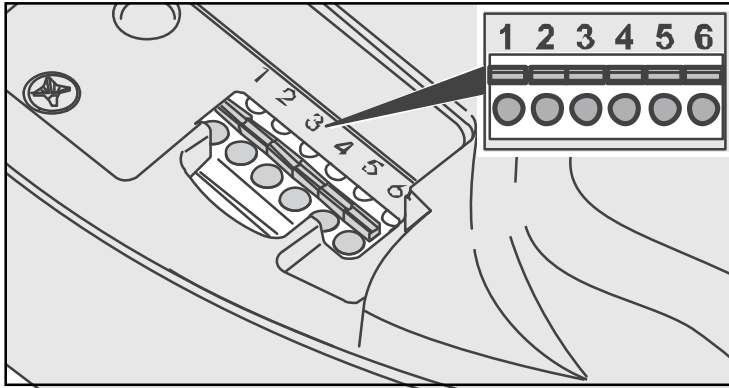

Description	Connection to terminal	Function / Application example
DC 24 Volt	1 + 2	Corresponding accessories with 24 volt voltage can be connected.
Command	3 + 4	A control device can be connected, for example a wall station or a button.
Photo eyes	5 + 6	The supplied photo eyes are connected here.

16. Maintenance and care

16.1. Maintenance schedule

When	Where	How
Once a month	Testing the emergency release function	See chapter "12.4. Test the emergency release".
	Testing obstacle detection function	See chapter "12.5. Test the obstacle detection function".
	Checking the photo eyes function.	See chapter "12.6. Test the photo eyes function".
Once a year	Check the door and all moving parts	According to the manufacturer's instructions
	Check the mounting bolts of the opener	Check for tightness and tighten if necessary
As needed	Clean the chain and C-rail	See chapter "16.3. Maintenance work".
	Clean the control housing and the carriage	With a dry lint-free cloth

16.2. Regular maintenance

Maintain and service your opener frequently as described in the following. This will ensure a safe operation and increases the operating life of your opener.

WARNING

There is a possible risk of injury or death through electrical voltage from improper cleaning with water.

Never hose down the opener or the control housing with water or with a high-pressure cleaner. This can lead to a short-circuit.

There is a possible risk of injury or death if the opener is turned on accidentally. You must disconnect the opener from the power supply when performing any work on the door. Pull out the power plug from the power outlet or switch off the on-site circuit breaker or disconnect the on-site fuse for the circuit that supplies the opener with voltage. Subsequently test to be sure the opener is disconnected from the power by switching it on (the opener should not move).

Never touch or grab the moving door or other moving parts. You could be crushed or jammed by the mechanics or the closing edges of the door.

CAUTION

There is a possible risk of damaging the opener surface by the use of improper cleaning agents.

Never clean the opener with aggressive cleaning agents such as acids or bases. Only use the specified cleaning agents and methods.

WARNING

There is a possible risk of injury or death through an accidentally switched on opener.

You must disconnect the opener from the power supply when cleaning the opener. Pull out the power plug from the power outlet or switch off the on-site circuit breaker or disconnect the on-site fuse for the circuit that supplies the opener with voltage. Subsequently test to be sure the opener is disconnected from the power by switching it on.

16.3. Maintenance work

Clean the chain and C-rail

1. Pull the power plug out of the power outlet.
Or if a direct connection from the power main supply:
2. Disconnect the opener from the power (switch off the circuit breaker to the opener or disconnect the fuse on the circuit supplying the opener with voltage) and check to be sure no voltage is present.
3. Remove loose dirt from the C-rail.
4. The chain and the inside of the c-rail must be cleaned with a lint-free cloth and lubricated with an electrically conductive lubricant (WD-40).
Never oil or grease the chain or c-rail. This can lead to a malfunction caused by insufficient electrical contact.
5. Plug in the power plug into the power outlet or
6. Switch on the electrical supply for a direct electrical connection (switch on the circuit breaker or fuse).

17. Troubleshooting

17.1. Troubleshooting guide

The following troubleshooting guide will help you to find possible problems and their causes as well as information on how you can fix these yourself. In specific cases, other chapters and sections are referenced in which the procedures are described in more detail. You will be instructed if you have to contact a trained specialist.

WARNING

There is a possible risk of injury or death if certain work for troubleshooting is carried out without having the corresponding expertise.

For specific troubleshooting work, technical knowledge is necessary. Have the cause repaired by a trained specialist only when you are instructed to do so in the troubleshooting overview.

Problem	Possible reason	Test/Check	Solution
Opener does not operate from either wall station nor transmitter	1. No power present	1. „Status“ LED on control housing is not lit	1. Check the power outlet with a different device, for example by plugging in a drill or a lamp
	2. Electrical supply voltage outside of the tolerance range	2. Have the main voltage checked by a electrician	2. Have the cause repaired by a electrician
	3. Photo eyes not mounted and connected	3. „Safety“ LED on the control housing is lit	3. Mount the photo eyes and connect. Terminal 5 and 6
	4. Photo eyes interrupted	4. „Safety“ LED on the control housing is lit. Are any objects in the path of the photo eyes?	4. Remove object. Readjust photo eyes
	5. Opener/controller defective	5. Opener does not start with transmitter, wall station or button	5. Have the opener repaired by a specialist or have the opener replaced
	6. Vacation mode on	6. LED „Command“ on the control housing illuminated. LED on the wall station illuminated red	6. Unlock the opener by pressing the „Lock/Unlock“ button (approx. 8 seconds) on the wall station
	7. Opener has been disengaged via emergency release mechanism	7. Move door by hand	7. Engage the opener by pulling on the emergency release handle
	8. Maximum wire length to wallstation 66ft. (20 m) exceeded	8. LED on the wall station is not illuminated. Try connecting the wall station to the opener with a short wire as a test	8. Connect the wall station using a properly functioning wire
	9. Wall station not mounted or connected	9. Green LED on the wall station does not lit up	9. Mount the wall station and connect
	10. Broken wire/ short circuit	10. LED on the wall station or photo eyes do not lit up	10. Repair or replace the wire
	11. Wall station or button incorrectly connected to the opener	11. Opener functions with transmitter and points 6,8,9,10,11 are OK	11. Wall station or button must be connected to terminal 3 and 4
	12. Wall station defective	12. –	12. Replace wall station
	13. Rail slide in part (with contact strip) is not in the correct position or is upside down	13. Remove control housing and check if the contacts are visible	13. Slide in part with contact must be on the side where the control housing is attached

17. Troubleshooting

Problem	Possible reason	Test/Check	Solution
Opener does not open or close the door after pressing a button on the transmitter	1. See points 1, 2, 3, 4, 5, 6, 7 above	1. See points 1, 2, 3, 4, 5, 6, 7 above	1. See points 1, 2, 3, 4, 5, 6, 7 above
	2. Transmitter not programmed	2. "Command" LED does not light up when the transmitter is operated	2. Program the transmitter
	3. Transmitter defective	3. LED on the transmitter does not light up	3. Replace the transmitter
	4. Battery empty	4. –	4. Replace the battery, see "Troubleshooting"
	5. Short circuit, for example through contact with the chain and C-rail from damaged chain channel	5. Check the fuse in the opener	5. Replace fuse in the opener, see "Troubleshooting"
Light on the opener does not function	1. See points 1, 2 above	1. See points 1, 2 above	1. See points 1, 2 above
	2. No light bulb installed	2. Open the cover and check if light bulbs are installed	2. Replace light bulbs, see chapter "Using for the first time"
	3. Defective light bulb	3. –	3. Replace the light bulbs, see "Troubleshooting"
Opener stops while the door is closing and opens the door again completely	1. Door contacted an obstacle	1. Check the area of the door's motion for possible object present	1. Remove object
	2. Photo eyes were interrupted	2. Check LEDs on the photo eyes and "Safety" LED on the control housing	2. Remove obstacle
	3. Photo eyes defective or not aligned	3. LEDs on the photo eyes should be solid. "Safety" LED on the control housing should be off	3. Align the photo eyes to each other
Opener stops while the door is opening	1. Door contacted an obstacle	1. Check the area of the door's motion for possible object present	1. Remove object
Opener opens the door but does not respond to any commands from the transmitter or wall station	1. Photo eyes were interrupted	1. "Safety" LED on the control housing is lit. Check the area of the door's motion for possible object present	1. Remove object
	2. Photo eyes defective or not aligned	2. Check LEDs on the photo eyes and "Safety" LED on the control housing	2. Align the transmitter and receiver to each other or replace
	3. End switch "Door CLOSE" in the carriage defective	3. a) Unlock opener and slide the carriage to the middle of the running rail. b) Lock the opener. c) Operate the transmitter or wall station. If the opener still opens and does not close the door, the end switch "Door OPEN" is defective	3. Have the end switch replaced by a specialist

17. Troubleshooting

Problem	Possible reason	Test/Check	Solution
Opener closes the door but does not respond to any commands from the transmitter or wall station	1. Photo eyes are interrupted by object	1. Check the area of the door's motion for possible object present	1. Remove object
	2. Photo eyes defective or misaligned	2. LEDs on the photo eyes should be solid. "Safety" LED on the control housing should be off	2. Align the transmitter and receiver to each other or replace
	3. End switch "Door OPEN" in the carriage defective	3. a) Unlock operator and slide the carriage to the middle of the running rail. b) Lock the operator. c) Operate the transmitter, wall station or button. If the operator now still closes and does not open the door, the end switch "Door CLOSE" is defective	3. Have the end switch replaced by a specialist
Speed varies while opening and closing the door	1. Opener starts slowly and then accelerates	1. –	1. Immediate running, normal procedure
	2. C-rail dirty	2. –	2. Clean the chain and C-rail and lubricate again. See chapter "Maintenance"
	3. Chain lubricated with incorrect oil	3. –	3. Clean the chain and C-rail and lubricate again. See chapter "Maintenance"
	4. Chain tightened incorrectly	4. –	4. Tighten the chain, see chapter "Installation"
"Radio" LED on the control housing is lit permanently	1. Continuous signal from transmitter. Button is possibly jammed	1. Check all programmed transmitters	1. Remove the battery from the transmitter
"Status" LED on the control housing is lit permanently	1. Opener is in operation	1. –	1. Normal display.
"Safety" LED on the control housing is lit permanently	1. Photo eyes defective or not aligned	1. –	1. Set the photo eyes, exchange or remove object from the monitoring area
	2. Photo eyes wire damaged, i.e. staple	2. Check photo eyes wire	2. Repair or replace the wire
	3. Photo eyes connection wires incorrectly inserted into the connection terminal	3. Pull lightly on the wire. Check if connected to Terminal 5 and 6	3. Reinsert the wire into the terminal. Connect wires to terminal 5 and 6
"Command" LED on the control housing is lit permanently	1. Continuous signal from wall station	1. Check the buttons on the wall station	1. Replace wall station
	2. Continuous signal of a transmitter present	2. Check all transmitters for correct functioning, "Radio" LED is not continuously lit or blinking	2. Remove the battery, see "Troubleshooting" and exchange the transmitter
	3. Continuous signal of an interfering device, i.e. a cell phone or baby monitor	3. Continuously lit or blinking "Radio" LED, check the frequencies with radio scanner	3. –
	4. Opener locked by the wall station	4. LED on the wall station lit up red	4. Press the button (locking) on the wall station for 8 seconds until the LED lights up green

17. Troubleshooting

Problem	Possible reason	Test/Check	Solution
The opener light and the “Status” LED blink	1. Controller malfunction	–	1. Disconnect the power plug, wait one minute, plug in the power plug (opener performs self test)
	2. Opener did not learn the values of the door	-	2. Press reset button for 5 sec. and open and close the door two times

17.2. Photo eyes fault indicators

Indicator		Problem	Test/Check	Solution
Transmitter (green LED)	Receiver (red LED)			
Off	Off	1. Opener does not function	1. Check the circuit breaker or fuse for the circuit or check the power plug	1. Switch on the circuit breaker or fuse for the circuit or plug in the power plug
		2. Wire broken	2. Check the wire for a short circuit and breakage	2. Repair or replace the wire
Blinks	Off	1. Wire to receiver damaged	1. Check the wire to the receiver for a short circuit and breakage	1. Exchange or repair the wire to the receiver
		2. Receiver defective	2. Have the receiver checked by a specialist	2. Have the receiver replaced by a specialist
Off	Blinks	1. Wire to transmitter damaged	1. Check the wire to the transmitter for a short circuit and breakage	1. Exchange or repair the transmitter
		2. Transmitter defective	2. Have the transmitter checked by a specialist	2. Have the transmitter replaced
Blinks 2 x	Blinks	1. Transmitter and receiver not correctly aligned to each other		1. Align the transmitter and receiver to each other
Blinks	Blinks	1. Light path interrupted		1. Remove the object out of light path
		2. Transmitter or receiver defective	2. Have the transmitter and receiver checked by a specialist	2. Have the transmitter and receiver replaced
Blinks	Blinks 3 x	1. Receiver defective or faulty connection to the opener	1. Check connection	1. Have the receiver possibly replaced

17. Troubleshooting

17.3. Troubleshooting

Use only original manufacturer replacement parts, accessories and mounting material.

Replacing light bulbs

⚠ WARNING

There is a risk of injury or death through electrical voltage if you accidentally reach into the lamp socket when the opener is powered.

You need to disconnect the opener from the power supply before you replace the light bulb. Pull out the power plug from the power outlet or switch off the on-site circuit breaker or disconnect the on-site fuse for the circuit that supplies the opener with voltage. Subsequently test to be sure the opener is disconnected from the power by switching it on (the opener must not move).

CAUTION

There is a risk that the opener can be damaged or catch fire if you use higher wattage light bulbs than approved.

Use only the light bulbs specified in this manual.

The opener light consists of two light bulbs (each maximum 60 W, maximum 110 V, socket standard bulb, Ø 2"/51 mm).

1. Pull the power plug out of the power outlet.
Or for a direct connection to the power mains:
2. Disconnect the opener from the power (switch off the circuit breaker to the opener or disconnect the fuse on the circuit supplying the operator with voltage) and check to be sure no voltage is present.

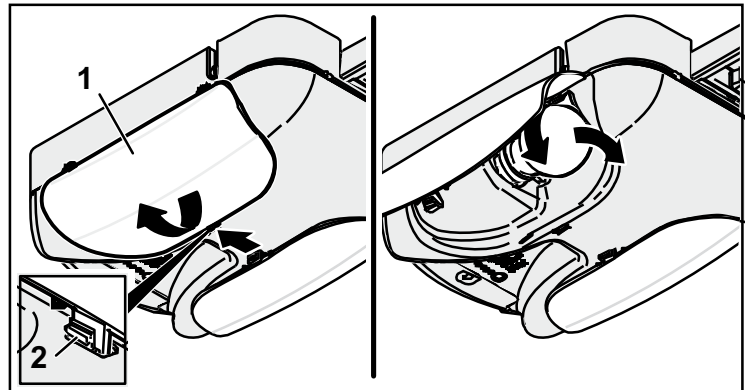

3. Open lamp cover (1) by pressing the latch (2).
4. Unscrew the light bulb in a counterclockwise direction.

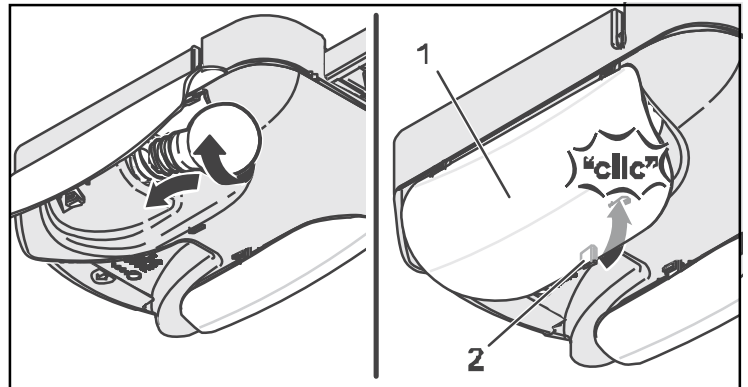

5. Screw in a new light bulb in a clockwise direction.
 6. Close the lamp cover (1); the latch must (2) snap into place.
 7. Plug in the power plug into the power outlet
- or**
8. Switch on the electrical supply for a direct electrical connection (switch on the circuit breaker or fuse).

17. Troubleshooting

Replacing transmitter battery

⚠ WARNING

There is a possible risk of injury or death if you do not observe and comply with the following information. Observe and comply with all listed instructions before handling the battery.

Do not store batteries where children can reach them. A child could play with them and accidentally swallow a battery. Call a doctor immediately if a battery is accidentally swallowed.

Never throw batteries into fire. As they can explode.

Never dispose batteries together with household waste. Leaking batteries can damage the environment. Please dispose of batteries properly according to your local regulations.

Pack the batteries individually for storage or for disposal. Batteries should never come into contact with metal objects, as they can ignite, discharge, or get damaged.

Only replace batteries with batteries specified in this manual.

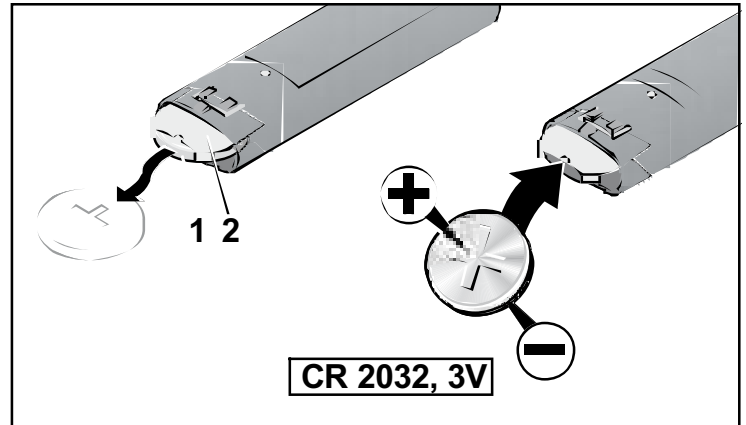

2. Remove the battery (1) from the retainer (2) and install a new battery (type CR 2032, 3 V) in the same position. + side of the battery to the retainer base! (as shown in the diagram)
3. Before sliding the unit back together, check if the battery was inserted correctly.
4. Press a button on the transmitter. The LED must light up. If the LED does not light up, the battery must be installed in the opposite direction.

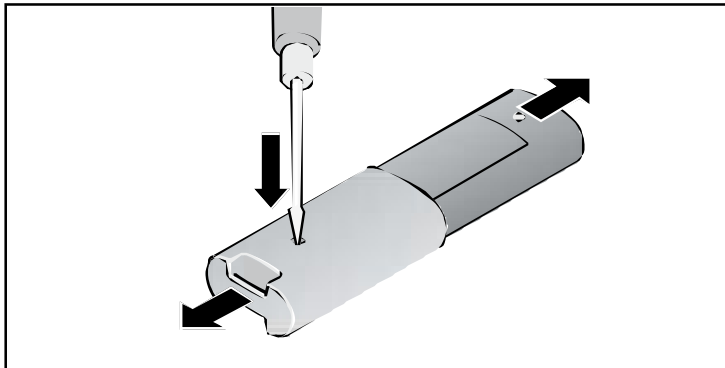

1. Push down the locking device and detach the remote device sections from each other.

⚠ Warning

There is a possible risk of injury when assembling the transmitter. You could pinch your fingers when assembling.

Proceed carefully when inserting the transmitter body into the stainless steel case.

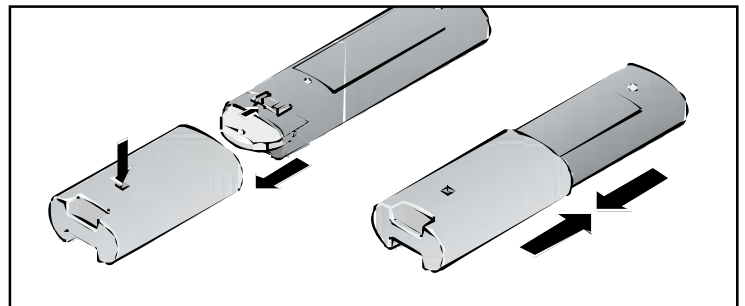

5. Slide together the remote control sections until the locking device engages.

18. Placing out of operation and disposal

18.1. Placing the opener out of operation

No electrical voltage should be present if the opener and accessory parts are to be taken out of operation or deinstalled. Pull out the power plug from the power outlet or switch off the on-site circuit breaker or disconnect the on-site fuse for the circuit that supplies the opener with voltage. Test to be sure the opener is disconnected from the power by switching it on (the opener should not move). After following these instruction you may now begin with the deinstallation.

Waste disposal

Please dispose all components that have been placed out of operation properly according to your local waste regulations.

18.2. Battery disposal

WARNING

There is a possible risk of injury or death if you do not observe and comply with the following information. Therefore, observe and comply with all listed instructions before disposing of batteries.

Never throw batteries into fire. As they can explode.

Never dispose batteries with your household waste. Leaking batteries can damage the environment. Please dispose batteries properly according to your local regulations.

Pack the batteries individually for disposal. Batteries should never come into contact with metal objects, they could ignite, discharge or get damaged.

19. Wiring diagram

⚠ DANGER

There is a risk of injury or death through electrical voltage if you do not observe and comply with the following information.

Electrical work may only be performed by a qualified electrician!

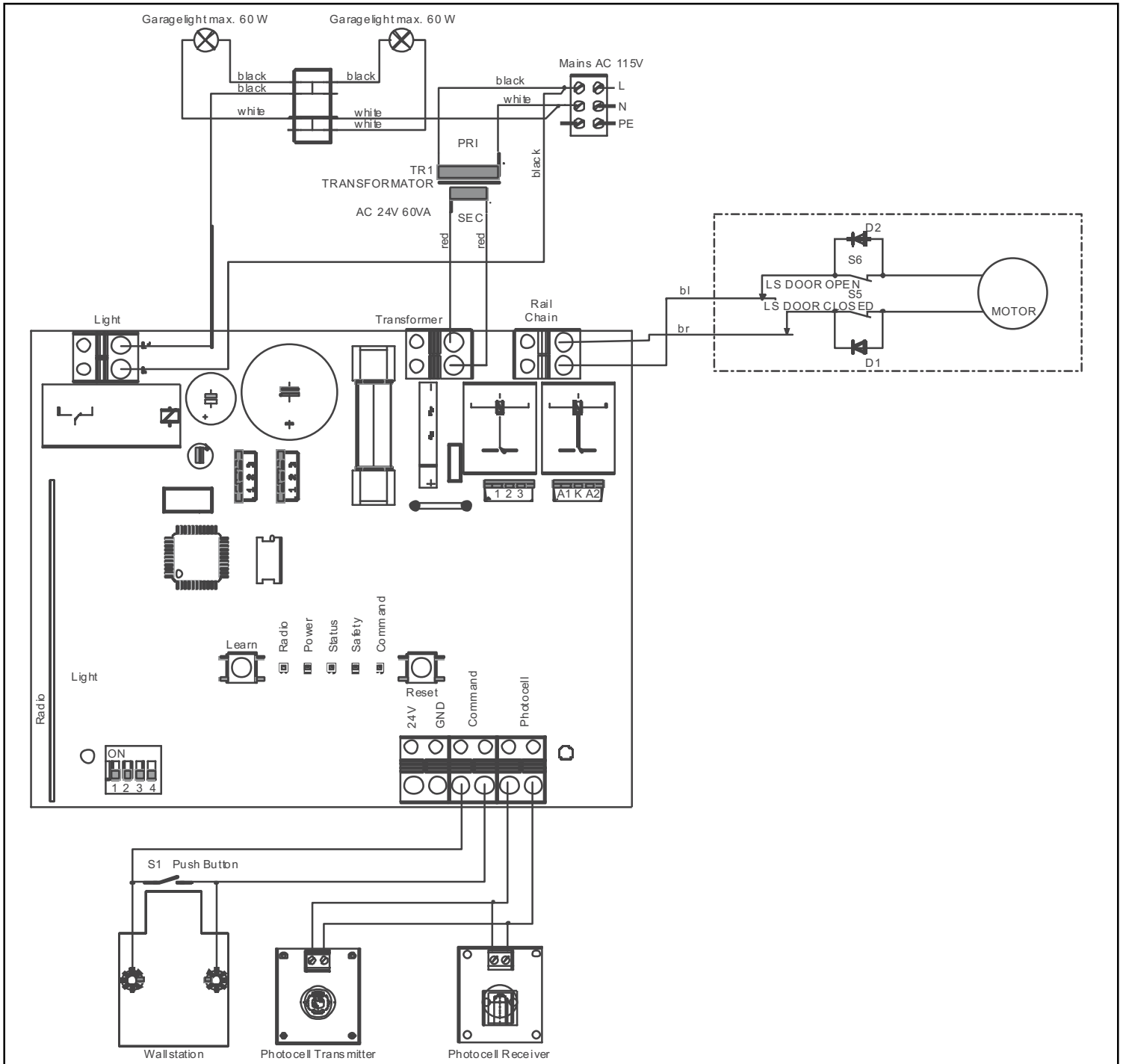

20. Warranty terms and conditions

Lifetime and Two (2) Year Limited Warranty

NOTICE: LIFETIME AND TWO (2) YEAR LIMITED WARRANTY GIVES YOU CERTAIN RIGHTS. PLEASE READ THE FOLLOWING CAREFULLY. ALL RIGHTS NOT EXPRESSLY GRANTED ARE RESERVED BY THE MANUFACTURER.

Registration is possible by mail with the enclosed registration card or via internet at www.sommer-usa.com

The manufacturer provides a limited warranty and warrants its products and/or components and accessories that were purchased and are used in America, to be free from defects in material and workmanship from the date of the retail purchase or initial installation of the product, whichever is earlier, for the following time periods.

- Lifetime for the entire garage door opener for the first purchaser
- Two (2) Years for the accessories such as transmitter, wall station, photo eye etc.

In addition, the manufacturer warrants the availability of OEM spare parts or equivalent parts for a period of Ten (10) Years from the date of the original retail purchase and product registration.

THIS LIMITED WARRANTY IS IN LIEU OF ANY OTHER WARRANTIES, EXPRESS OR IMPLIED, INCLUDING ANY IMPLIED WARRANTY OF MERCHANTABILITY OR FITNESS FOR A PARTICULAR PURPOSE, USE OR OTHERWISE, AND OF ANY OTHER OBLIGATIONS OR LIABILITY ON THE MANUFACTURER'S PART.

This warranty is not transferable and only available to the original retail purchaser and for the first retail installation.

In the event of a defect in material or workmanship during the respective warranty periods specified above, from the date of the retail purchase or initial installation of the product, whichever is earlier, the manufacturer will, at the manufacturer's sole discretion, repair or replace the product and/or any defective parts, components or accessories on the terms and conditions and with the limitations and exclusions as set forth below.

This warranty does not cover normal wear and tear, damage caused by corrosion, erosion, abrasion or similar causes, damage caused by improper repair and/or use of non OEM spare parts or components, including any use not specifically authorized in the installation and operating manual as well as

any use expressly forbidden by the installation and operating manual.

This warranty does not apply to consumables and parts that routinely wear out over time like light bulbs, batteries and fuses.

If there are problems with the product and/or any of its components, first refer the troubleshooting section of the installation and operation manual and/or the on-line troubleshooting guide and tips available at www.sommer-usa.com.

If the problem cannot be solved call **+1-704-424-5787** from **8:30 A.M. to 5:00 P.M.** Eastern Time, Monday through Friday to speak to a customer service technician.

Have the following information handy:

- The model number
- The serial number
- The date of manufacture or installation
- The internet product registration number

and

- A description of the malfunction, defect or problem

The more complete information you provide, the better the customer service technician will be able to assist you quickly.

When you call, the customer service technician will first attempt to troubleshoot and solve the problem over the phone.

If the problem cannot be solved over the phone, the customer service technician will decide whether the product must be shipped to a service center for diagnosis and repair.

If the product must be shipped to a service center for repair, the customer service technician will provide the shipping information, packaging instructions and a RGA (Return Goods Authorization) number, which must be clearly marked on the shipping carton.

Do not ship the product without having first obtained a RGA.

Always write the RGA number on the shipping carton.

Shipping charges to the service center are to be paid by the customer.

Upon receipt of the product at the service center, the repair technicians will examine the product and determine if warranty coverage applies.

20. Warranty terms and conditions

If warranty coverage applies, the product will be repaired and defective parts will be replaced with new or reconditioned parts or parts of similar design, as the manufacturer may in its sole discretion decide, and the product will then be returned to the customer, shipping charges pre-paid by the manufacturer, within 14 days.

Any replaced parts become the property of the manufacturer who is free to discard them.

If it is determined that no warranty coverage is available either because the coverage period has passed or for example if the defect is due to improper installation, use of non-OEM spare parts or other not covered causes, the customer will be informed of this fact and given an estimate for the repair and return of the product.

Any repairs and/or exchanges performed under this limited warranty do not extend the warranty period beyond the respective time limits set forth above.

This limited warranty shall be null and void in case of abuse, neglect, accident, acts of God, disaster, misuse, mishandling, improper installation, improper operation, unauthorized repair or modification, use of non-proprietary, after market or non-OEM spare parts, or failure to follow the manufacturer's instructions with respect to the proper installation, handling, operation, service and maintenance of the product as outlined in the installation and operating manual.

THE TERMS OF THIS LIMITED WARRANTY CANNOT BE ALTERED OR CHANGED IN ANY FASHION OR UNDER ANY CIRCUMSTANCES EXCEPT BY WAY OF A WRITING FROM THE MANUFACTURER'S HEADQUARTERS SIGNED BY A CORPORATE OFFICER SPECIFICALLY AUTHORIZED TO DO SO.

THIS LIMITED WARRANTY IS LIMITED TO THE REPAIR OR REPLACEMENT OF THE PRODUCT AND/OR ITS COMPONENTS OR PARTS.

THIS LIMITED WARRANTY DOES NOT APPLY TO AND DOES NOT COVER ANY PROBLEMS WITH, RELATED TO OR CAUSED IN ANY WAY BY THE GARAGE DOOR ITSELF, THE GARAGE DOOR HARDWARE, INCLUDING BUT NOT LIMITED TO SPRINGS, LOCKS, ROLLERS, TRACKS, HINGES, ALIGNMENT OF TRACKS, ALIGNMENT OF HINGES, AND OTHER PARTS NOT SUPPLIED BY THE MANUFACTURER.

THIS LIMITED WARRANTY IS IN LIEU OF ANY OTHER WARRANTIES, EXPRESS OR IMPLIED, INCLUDING ANY IMPLIED WARRANTY OF MERCHANTABILITY OR FITNESS FOR A PARTICULAR PURPOSE, USE OR OTHER-

WISE, AND OF ANY OTHER OBLIGATIONS OR LIABILITY ON THE MANUFACTURER'S PART.

NOTWITHSTANDING THE PREVIOUS SENTENCE, ANY IMPLIED WARRANTY OF MERCHANTABILITY OR FITNESS FOR A PARTICULAR PURPOSE OF THIS PRODUCT IS LIMITED TO THE LIFETIME OR TWO (2) YEAR DURATION PERIODS OF THIS WRITTEN WARRANTY AS SET FORTH ABOVE.

ALL WARRANTIES SET FORTH IN THIS WARRANTY ARE LIMITED TO THE LIFETIME OR TWO (2) YEAR DURATION PERIODS FROM THE DATE OF THE ORIGINAL RETAIL PURCHASE OR INSTALLATION, WHICHEVER IS EARLIER. NO WARRANTIES WHATSOEVER WILL COVER THE PRODUCT AND/OR ITS COMPONENTS, PARTS OR ACCESSORIES BEYOND THE LIFETIME OR TWO (2) YEAR DURATION PERIODS.

HOWEVER, SOME STATES DO NOT ALLOW LIMITATIONS ON HOW LONG AN IMPLIED WARRANTY LASTS, SO IN SUCH STATES THE ABOVE LIMITATION(S) MAY NOT APPLY TO YOU.

IF THIS PRODUCT IS DEFECTIVE, YOUR ONLY REMEDY IS REPAIR OR REPLACEMENT, AS DESCRIBED ABOVE.

TO THE MAXIMUM EXTENT PERMITTED UNDER APPLICABLE LAW, IN NO EVENT AND UNDER NO CIRCUMSTANCES WILL THE MANUFACTURER, ITS DISTRIBUTORS, DEALERS, INSTALLERS OR THEIR AGENTS BE LIABLE FOR ANY SPECIAL, INCIDENTAL, INDIRECT, PUNITIVE OR CONSEQUENTIAL DAMAGES, INCLUDING BUT NOT LIMITED TO ANY LOST PROFITS, LOST COMPENSATION OF ANY KIND, BUSINESS INTERRUPTION, DOWN TIME, OR ANY OTHER DAMAGES CAUSED BY THE MANUFACTURER'S BREACH OF WARRANTY, NEGLIGENCE OR BREACH OF CONTRACT.

TO THE MAXIMUM EXTENT PERMITTED UNDER APPLICABLE LAW, IN NO EVENT AND UNDER NO CIRCUMSTANCES WILL THE MANUFACTURER, ITS DISTRIBUTORS, DEALERS, INSTALLERS OR THEIR AGENTS BE LIABLE FOR ANY SPECIAL, INCIDENTAL, INDIRECT, PUNITIVE OR CONSEQUENTIAL DAMAGES, INCLUDING BUT NOT LIMITED TO ANY LOST PROFITS, LOST COMPENSATION OF ANY KIND, BUSINESS INTERRUPTION, DOWN TIME, OR ANY OTHER DAMAGES CAUSED BY THE USE OF THIS PRODUCT OR INABILITY TO USE IT, EVEN IF THE MANUFACTURER, ITS DISTRIBUTORS, DEALERS, INSTALLERS OR THEIR AGENTS HAVE BEEN ADVISED OF SUCH LIABILITY CLAIMS OR OTHER CLAIMS OR THE POSSIBILITY OF SUCH CLAIMS OR OTHER CLAIMS.

20. Warranty terms and conditions

SOME STATES DO NOT ALLOW THE EXCLUSION OR LIMITATION OF INCIDENTAL, CONSEQUENTIAL OR OTHER DAMAGES, SO THE ABOVE LIMITATION OR EXCLUSION MAY NOT APPLY TO YOU.

THIS WARRANTY GIVES YOU SPECIFIC RIGHTS, AND YOU MAY HAVE OTHER RIGHTS WHICH MAY VARY FROM STATE TO STATE.

In the event of any questions, regarding this warranty, its coverage and/or exclusions, call **+1-704-424-5787** from **8:30 A.M. to 5:00 P.M.** Eastern Time, Monday through Friday to speak to a customer service technician.

SOMMER North America

SOMMER USA, Inc.

3308-C Oak Lake Blvd.
Charlotte, NC 28208
USA

Phone: +1-704-424-5787

Fax: +1-704-424-7699

info@sommer-usa.com

www.sommer-usa.com

SOMMER Germany

SOMMER Antriebs- und Funktechnik GmbH

Hans-Böckler-Straße 21-27
73230 Kirchheim/Teck,
Germany

Phone: +49 7021 8001-0

Fax: +49 7021 8001-100

info@sommer.eu

www.sommer.eu

© Copyright 2010 All rights reserved

This document was created with Win2PDF available at <http://www.win2pdf.com>.
The unregistered version of Win2PDF is for evaluation or non-commercial use only.
This page will not be added after purchasing Win2PDF.