

**EN748100TX Chicago Floating Shelf 48"-  
Chocolate**

**EN748200TX Chicago Floating Shelf 48"-  
Black**

**EN748300TX Chicago Floating Shelf 48"-  
White**

**Assembly Instructions**



**Southern**  
ENTERPRISES

For assistance with assembly contact:  
Southern Enterprises Inc.  
Customer Service 1-800-633-5096  
[service@seidal.com](mailto:service@seidal.com)  
[www.seidal.com](http://www.seidal.com)

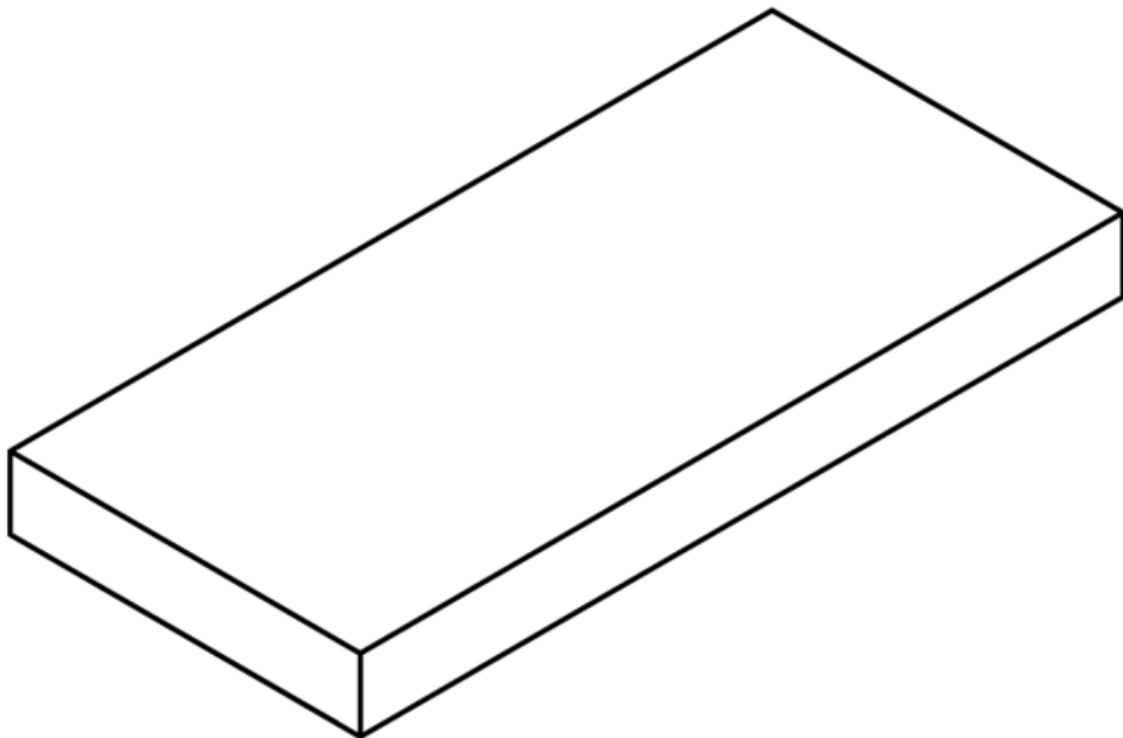

Max Loading weight:20Lbs

# Chicago Floating Shelf 48"

## Parts List

Please check packaging for all parts and hardware before discarding. Unpack and lay parts on clean, padded surface like carpet or blanket. Check that you have all parts indicated. Call customer service if hardware is missing.

Before beginning assembly, carefully study the diagrams below and sort your hardware according to the pictures.

Using the incorrect hardware will cause damage.

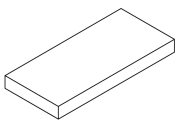
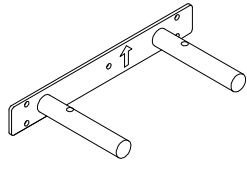
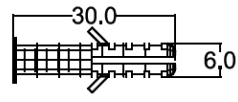
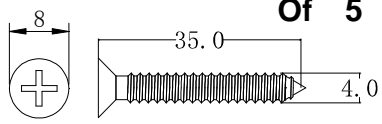
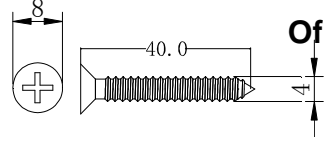
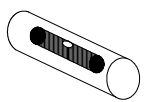
<p><b>A</b> <span style="float: right;"><b>Quantity</b> <b>Of 1</b></span></p>  <p>Shelf</p>	<p><b>B</b> <span style="float: right;"><b>Quantity</b> <b>Of 1</b></span></p>  <p>Bracket</p>	<p><b>C</b> <span style="float: right;"><b>Quantity</b> <b>Of 5</b></span></p>  <p>Plastic anchor 6 x 30mm</p>
<p><b>D</b> <span style="float: right;"><b>Quantity</b> <b>Of 5</b></span></p>  <p>Screw 8 x 35mm</p>	<p><b>E</b> <span style="float: right;"><b>Quantity</b> <b>Of 2</b></span></p>  <p>Screw 8 x 40mm</p>	<p><b>F</b> <span style="float: right;"><b>Quantity</b> <b>of 1</b></span></p>  <p>Levels</p>

**Care and Cleaning Instructions:**  
 Before using, wipe with a clean, dry cloth.  
 Periodically apply furniture wax to renew the finish. Avoid rubbing or scratching the surface with rough or abrasive objects.  
 For replacement parts or questions, please

Call Customer Service at 1-800-633-5096 for assistance, questions, or parts.

**Assembly Tool Required  
(Not Included)**

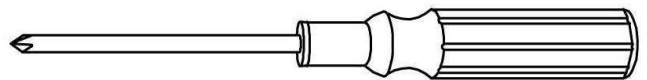

### Suggested tools as below list

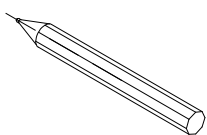
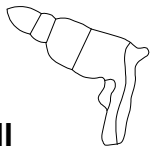
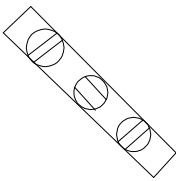
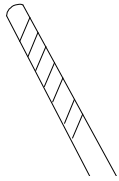
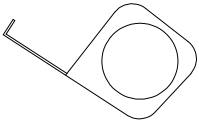
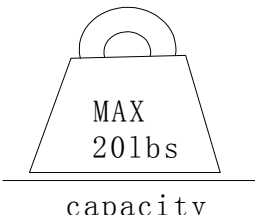
 <p>Pencil</p>	 <p>Power drill</p>	 <p>Level</p>
 <p>Bit 3/16"</p>	 <p>Tape measure</p>	 <p>MAX 20lbs capacity</p>

# Chicago Floating Shelf 48" Assembly Instructions

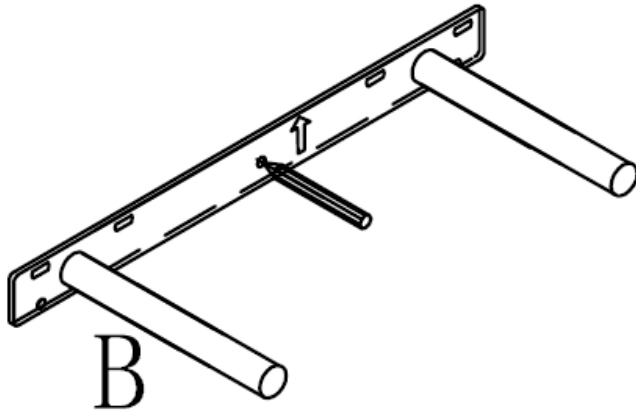

Figure 1

Place mounting bracket (B) against the wall at the desired location with the arrow pointing up on the.

Use a level on top of bracket to insure bracket is level, then, mark each hole with a pencil.

Remove the bracket.

Tip: If mounting to sheet rock (cavity wall) it is advisable to mount at least one screw (without anchor) directly to a wall stud.

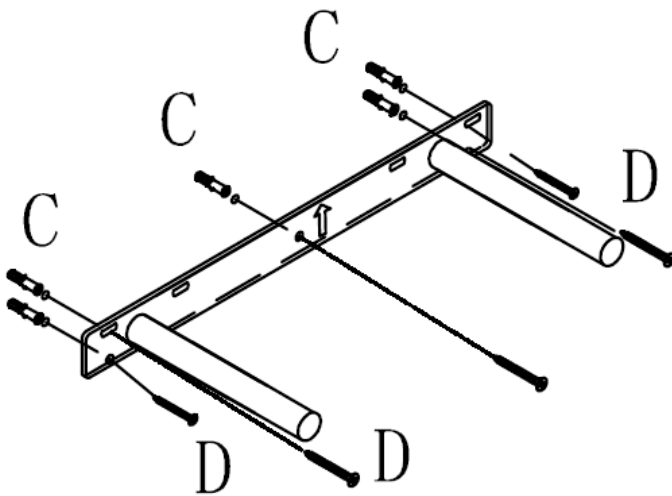
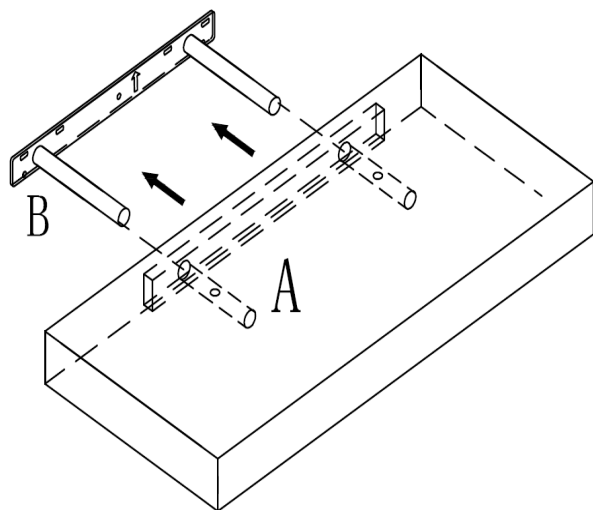

Figure 2

Using a power drill and 1/4" drill bit, drill a hole through the wall at each marked hole location where screw (D) will not hit a stud in the wall. Then insert plastic anchors (C) into each hole and lightly tap anchors (C) with a hammer until they are securely flush with the face of the wall. After the plastic anchors (C) are securely in place, position bracket (B) to be mounted to the wall. Using a philips screwdriver, drive in the screws (D) into plastic anchors (C) until the bracket (B) is securely placed on the wall.



Slide shelf (A) onto the mounting bracket (B) by aligning the two holes on shelf (A) to the poles on bracket (B), making sure the two small holes are pointing down on the bottom of shelf (A).

Figure 3

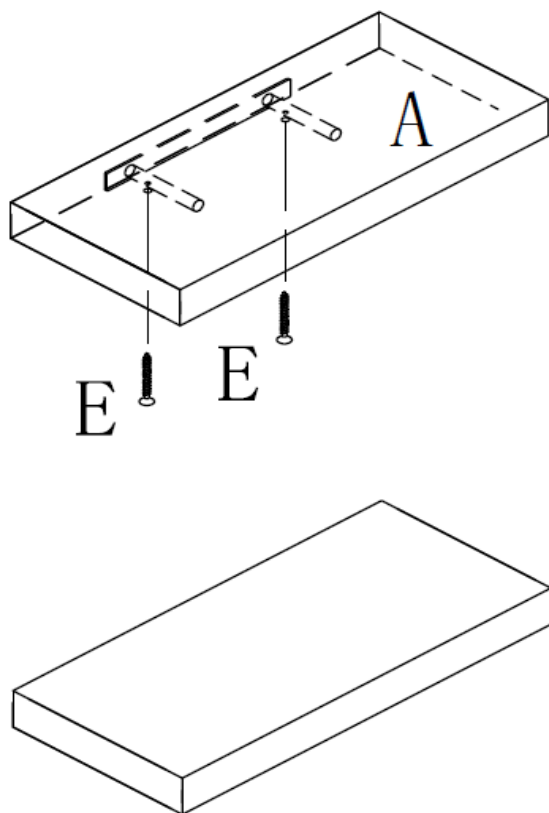

Insert the two long screws (E) with a screwdriver to secure shelf (A) to bracket (B).

Place level on top to insure product is level.

Now you shelf is ready to use.

Figure 4

# Parts Replacement Form

## Customer Information

Name \_\_\_\_\_

Address \_\_\_\_\_

City/State/Zip Code \_\_\_\_\_

Phone Number \_\_\_\_\_

Please indicate where you purchased this item: Store/Website/Catalog

\_\_\_\_\_

Please indicate color/size/style number:

\_\_\_\_\_

Style No  
Needed

Parts Letter

Parts Description

Quantity

\_\_\_\_\_

\_\_\_\_\_

\_\_\_\_\_

Please immediately examine this product carefully. Any request for missing parts or damage replacement must be received within 90 days of your receipt of the product. Replacement, if available, will be honored within this time frame. Parts will not be available for items arriving fully assembled. We do not recommend modifying product(s) and we are not responsible for any damages due to product modification(s). If damages or missing parts are not reported within 90 days of your receipt, we are under no obligation to provide parts or replacement merchandise.

Please contact Southern Enterprises at 800-633-5096 or in Dallas 972-869-0111/ 9am – 4pm Mon-Fri Central time if you have product issues or email us at [service@seidal.com](mailto:service@seidal.com). Please ask for customer service representative for issues involving damages or replacement parts. Please ask for technical assistance representative for any issues with product and assembly/construction.

Please contact the retailer that you purchased from for returns.



**Southern**  
ENTERPRISES

Customer Service 1-800-633-5096

[service@seidal.com](mailto:service@seidal.com)

Southern Enterprises, Inc.

600 Freeport Parkway, Suite 200

Coppell, Texas 75019



## CAUTION

**Max shelf load capacity is achieved by mounting screw into studs or cement walls.**

If mounting to sheet rock (cavity wall) it is advisable to mount at least 1 screw (without anchor) directly to a wall stud or studs. However do not leave either end of mounting bracket unsupported by at least one anchor. For hollow wall mounting you can use any of the holes in the back plate to suit where you require the mounting screws positioned.

**Note: Pipe bracket has a built in safety design feature. Pipes have a slight upward angle to prevent floating shelf from fogging when shelf is loaded. Weight ratings are E.D.L.(evenly distributed load)**