

H08808 – Mission Computer Desk

Assembly Instructions

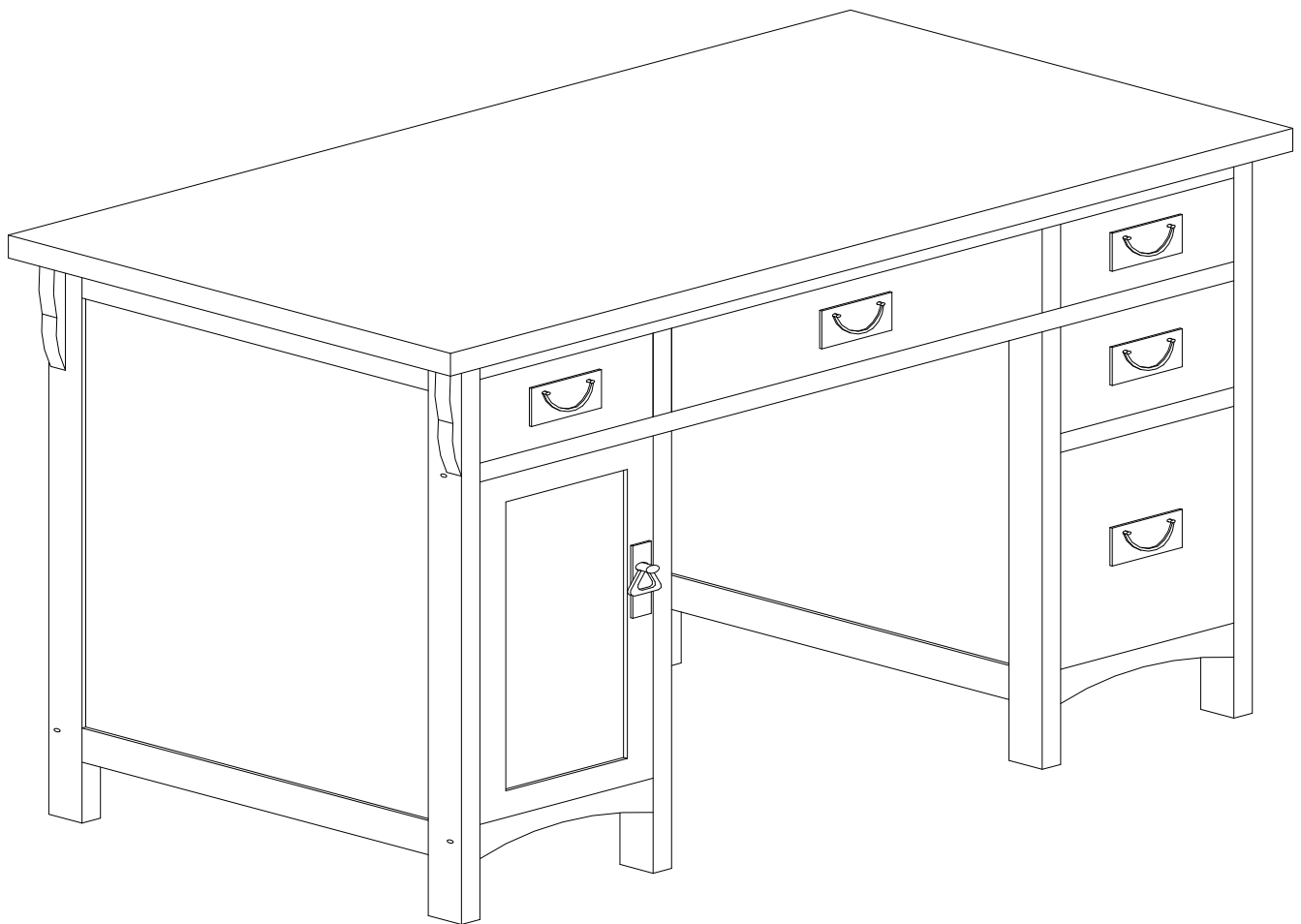





For assistance with assembly contact:
Southern Enterprises Inc.
Customer Service 1-800-633-5096
service@seidal.com
www.seidal.com

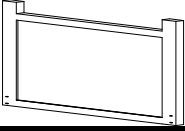

Mission Computer Desk Parts List

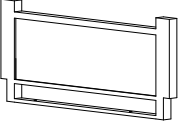
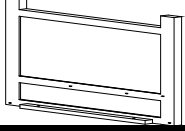
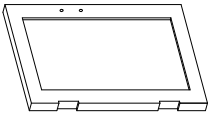
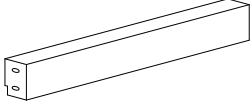
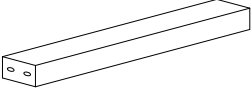
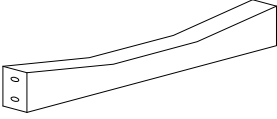
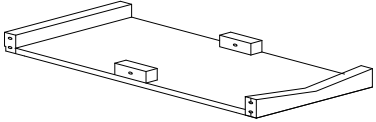
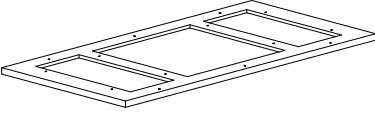
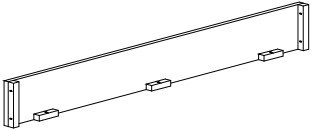
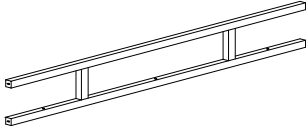
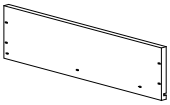
Please review all parts and hardware before disposing of any packaging. Call Customer Service if missing hardware. Do not return to store/retailer. Screws shown in actual size. Using a screw that is too long will cause damage. Before beginning assembly, separate each type of screw. Carefully study the screw diagrams below (SHOWN ACTUAL SIZE). You may receive extra hardware with your unit.

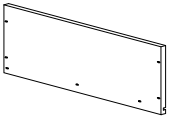
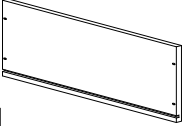
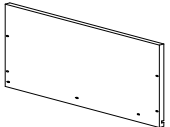
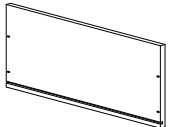
A Right Side Panel 	B Right Partition Board 
C Left Partition Board 	D Left Side Panel 
E Door 	F Back Lower Brace 
G Upper Brace 	H Front Lower Brace 
I Bottom Panel 	J Desk Top 
K Back Frame 	L Drawer Frame 
M Small Drawer Left Drawer Side Panel 	N Small Drawer Right Drawer Side Panel 
O Medium Drawer Left Drawer Side Panel 	P Medium Drawer Right Drawer Side Panel 
Q Big Drawer Left Side Drawer Panel 	R Big Drawer Right Side Drawer Panel 

Care and Cleaning Instructions:

Before using, wipe with a clean, dry cloth. Periodically apply furniture wax to renew the finish. Avoid rubbing or scratching the surface with rough or abrasive objects.

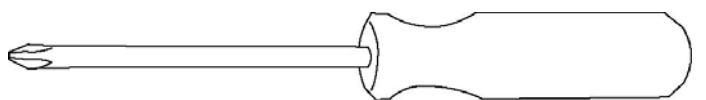

For replacement parts or questions, please Call Customer Service at 1-800-633-5096 Do not return product to store, please call Manufacturer for assistance, questions or Parts.

Assembly Tool Required
No.2 Phillips Screwdriver (Not Included)

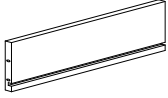
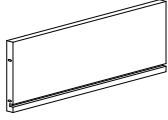
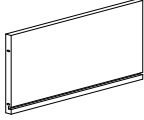
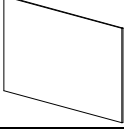
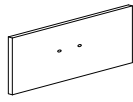
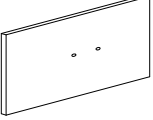
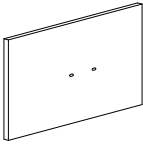
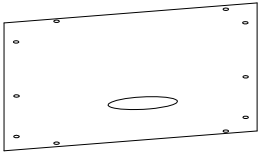
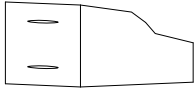
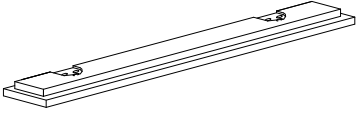
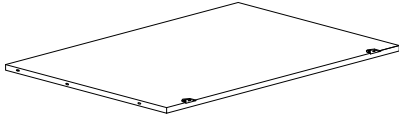
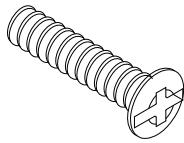
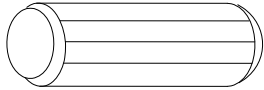
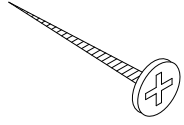

Mission Computer Desk Parts List

Please review all parts and hardware before disposing of any packaging. Call Customer Service if missing hardware. Do not return to store/retailer. Screws shown in actual size. Using a screw that is too long will cause damage. Before beginning assembly, separate each type of screw. Carefully study the screw diagrams below (SHOWN ACTUAL SIZE). You may receive extra hardware with your unit.

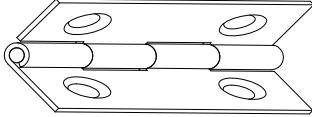
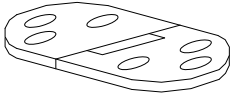

S Small Drawer Drawer Back		Quantity of 2	T Medium Drawer Drawer Back		Quantity of 1
U Big Drawer Rear Drawer Panel		Quantity of 1	V Drawer Bottom		Quantity of 4
W Small Drawer Drawer Front		Quantity of 2	X Medium Drawer Drawer Front		Quantity of 1
Y Big Drawer Front Drawer Panel		Quantity of 1	Z Back Panel		Quantity of 2
a Slot		Quantity of 4	b Keyboard Drawer Front		Quantity of 1
d Keyboard Drawer Bottom		Quantity of 1	1 Bolt(1/4"*1-1/4")		Quantity of 40
2 Wood Dowel		Quantity of 14	3 Wood Screw		Quantity of 32
4 Wood Screw(3*10mmL)		Quantity of 72	5 Wood Screw(3*12mmL)		Quantity of 22
6 Hinge		Quantity of 2	7 Hinge		Quantity of 2
Care and Cleaning Instructions: Before using, wipe with a clean, dry cloth. Periodically apply furniture wax to renew the finish . Avoid rubbing or scratching the surface with rough or abrasive objects.			For replacement parts or questions, please Call Customer Service at 1-800-633-5096 Do not return product to store, please call Manufacturer for assistance, questions or Parts.		

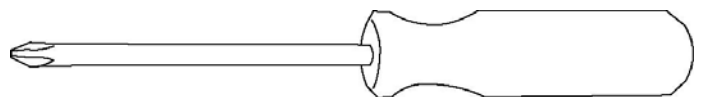
Assembly Tool Required
No.2 Phillips Screwdriver (Not Included)

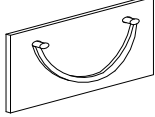

Mission Computer Desk Parts List

Please review all parts and hardware before disposing of any packaging. Call Customer Service if missing hardware. Do not return to store/retailer. Screws shown in actual size. Using a screw that is too long will cause damage. Before beginning assembly, separate each type of screw. Carefully study the screw diagrams below (SHOWN ACTUAL SIZE). You may receive extra hardware with your unit.

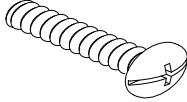
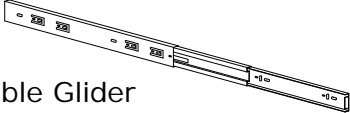
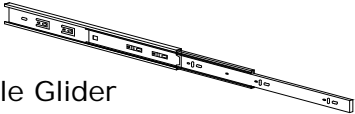
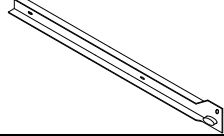
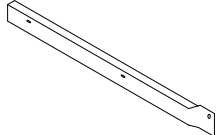
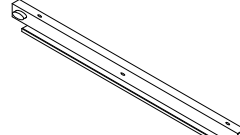
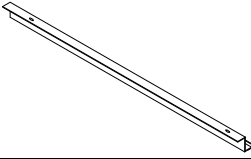
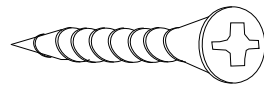
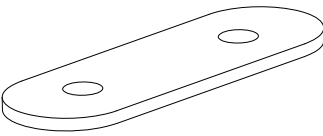
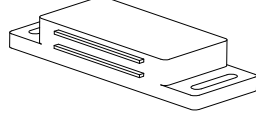
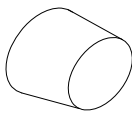
8 Handle 	9 Handle 
10 Small Bolt(5/32"*3/4"L) 	11 Left extendable Glider 
12 Right extendable Glider 	13 Right Bottom Glider 
14 Left Bottom Glider 	15 Right Top Glider 
16 Left Top Glider 	17 Wood Screw(3*14mmL) 
18 Magnet Pin 	19 Magnet 
20 Wood Plug 	

Care and Cleaning Instructions:
Before using, wipe with a clean, dry cloth. Periodically apply furniture wax to renew The finish. Avoid rubbing or scratching the Surface with rough or abrasive objects.

For replacement parts or questions, please Call Customer Service at 1-800-633-5096 Do not return product to store, please call Manufacturer for assistance, questions or Parts.

Assembly Tool Required
No.2 Phillips Screwdriver (Not Included)

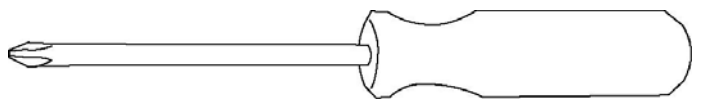

Mission Computer Desk Assembly Instructions

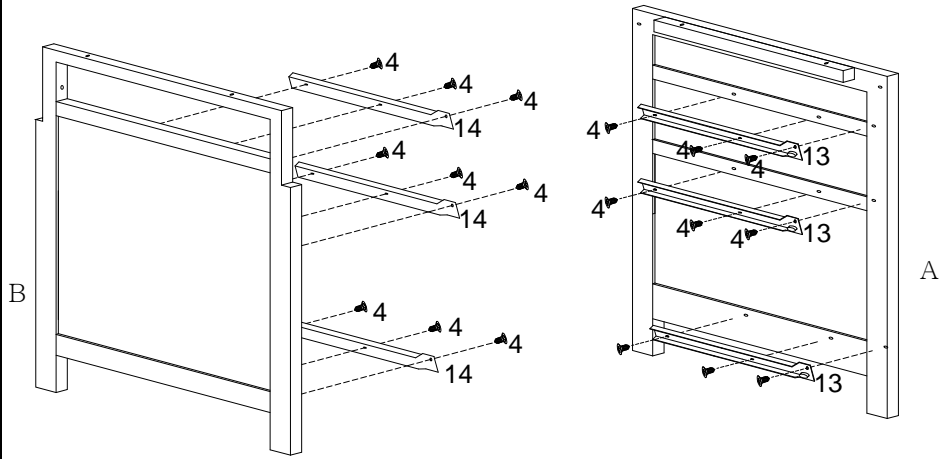

Figure 1

Assembly Instructions:

Wood may scratch easily, Be careful when assembling. Do not scratch.

Step 1 Unpack and lay parts on clean, padded surface like carpet or blanket. Check that you have all parts indicated on the front page.

Step 2 Set the desktop upside down on smooth padded surface.

Step 3 Attach Right/ Left Bottom Gliders (13&14) to the Right Side Panel (A) and Right Partition Board (B) with 18pcs Wood Screws (4) by using the Screwdriver.

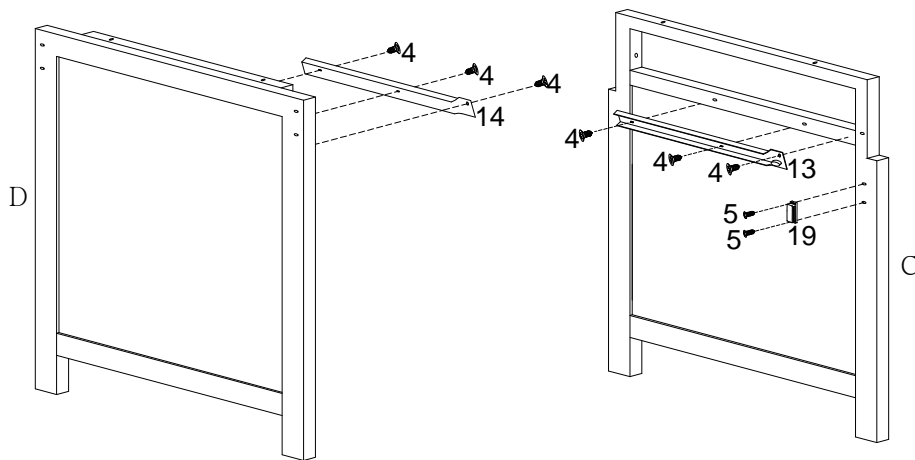

Figure 2

Attach Left/Right Bottom Gliders (13 & 14) to the Left Partition Board (C) and Left Side Panel (D) with 6pcs Wood Screws (4) by using the Screwdriver.

Fix the Magnet (19) to the Left Partition Board (C) with 2pcs Wood Screw (5) by using the Screwdriver.

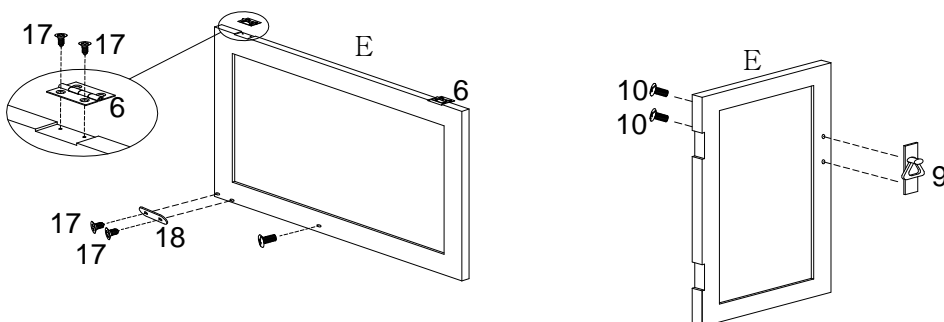

Figure 3

Attach 2pcs Hinge(6) and the Magnet Pin (18) to the Door (E) with 6pcs Wood Screw (17) , Fix the Handle (9) to the Door (E) with 2pcs Bolt (10) by using the Screwdriver.

Mission Computer Desk Assembly Instructions

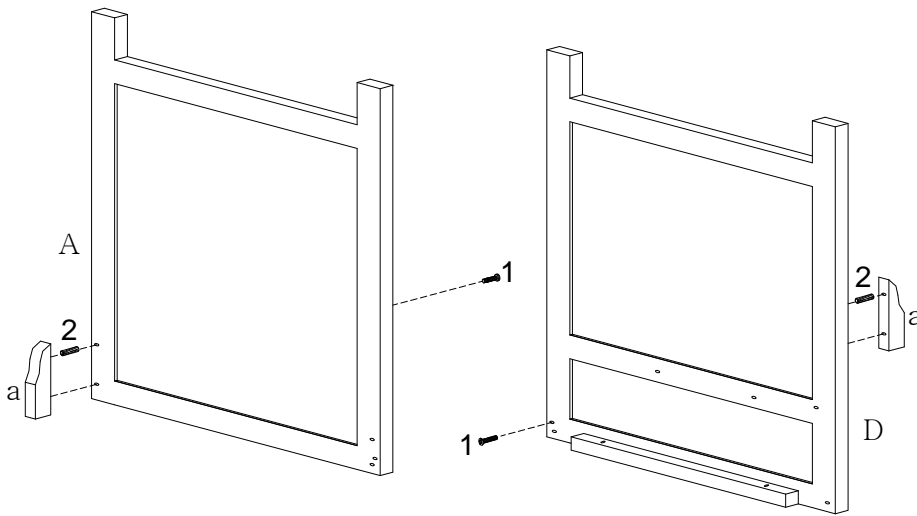

Figure 4

Connect the Slot (a) to the Right side panel (A) and Left side panel (D) with 2pcs Bolt (1) and 2pcs Wood Dowel (2) by using the Screwdriver.

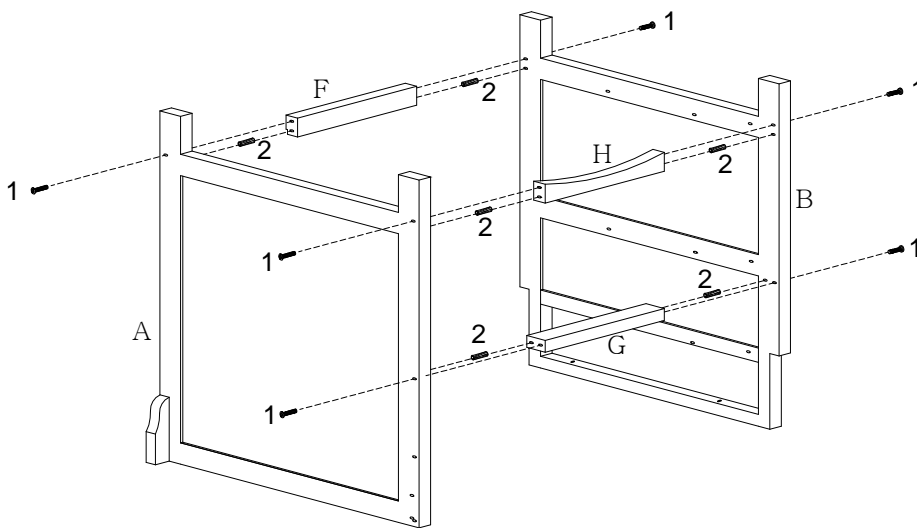

Figure 5

Connect the Right Side panel/Right Partition Board (A/B) with the Braces (F, H, G) by using 6pcs Wood Dowel (2) and 6pcs Bolt (1).

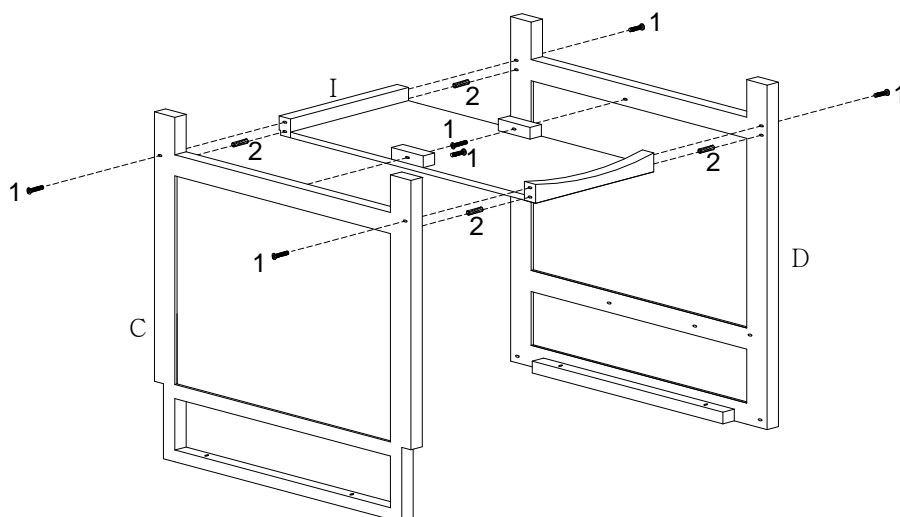

Figure 6

Connect the Left Partition Board/Side panel (C&D) with the Bottom Brace (I) by using 4pcs Wood Dowel (2) and 6pcs Bolt (1), tighten by using the screwdriver.

Mission Computer Desk Assembly Instructions

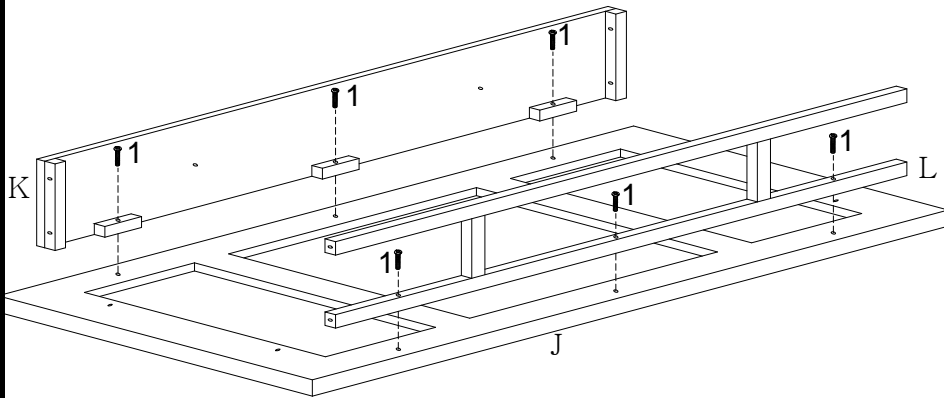

Figure 7

Connect the Desk Top (J), the Back Frame (K) and Drawer Frame (L) with 6pcs Bolt (1).

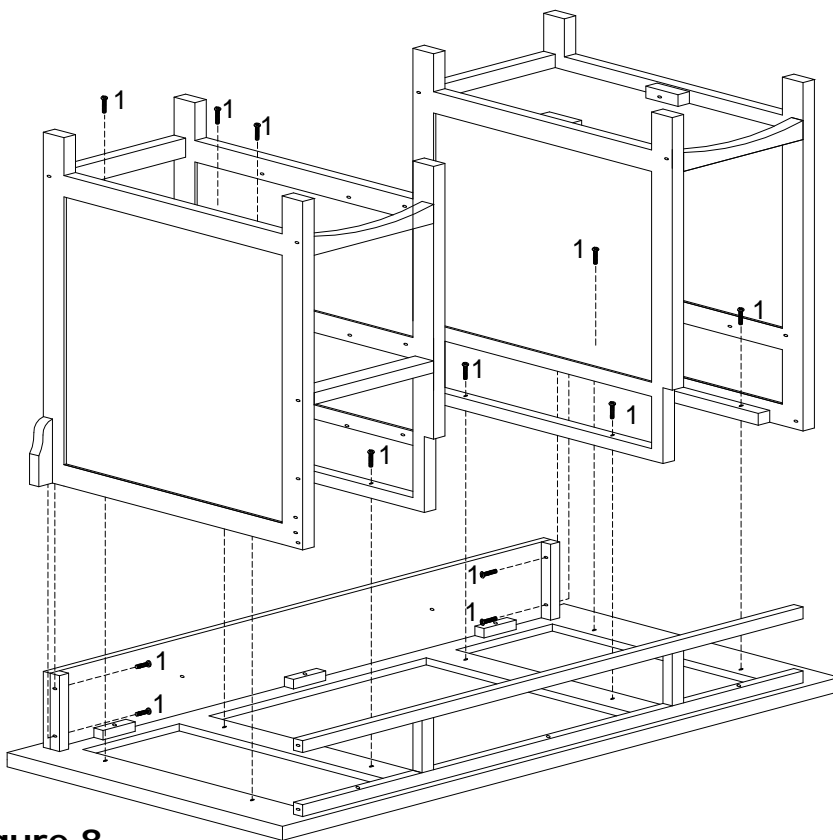

Figure 8

Attach the unit assembled at step5/ step6 to the unit assembled at step 7 with 12pcs Bolt (1) by using the screwdriver.

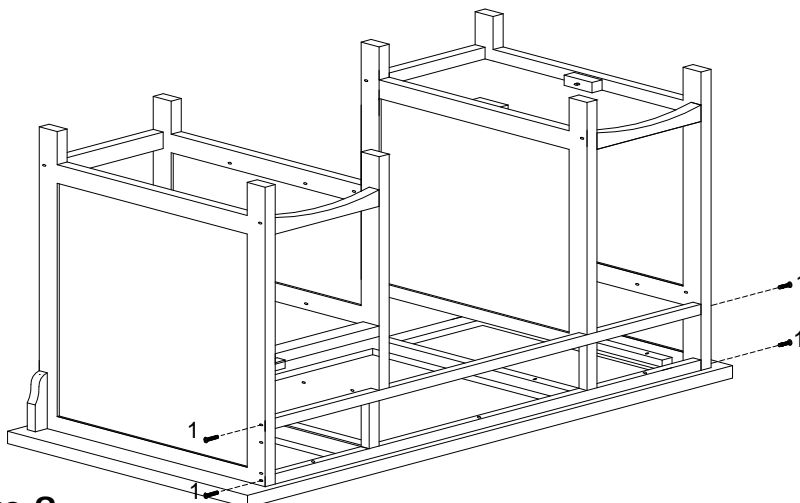

Figure 9

Connect the Drawer Frame to the Left/Right Side Panels (A/D) with 4pcs Bolt (1) by, tighten by using screwdriver.

Mission Computer Desk Assembly Instructions

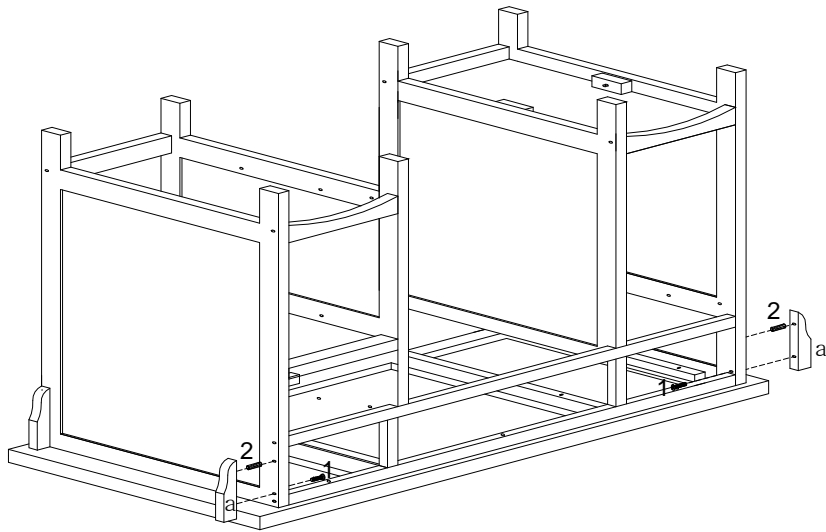

Figure 10

Connect the Slots (a) to the Left/Right Side Panels (A/D) with 2pcs Wood Dowel (2) and 2pcs Bolt (1).

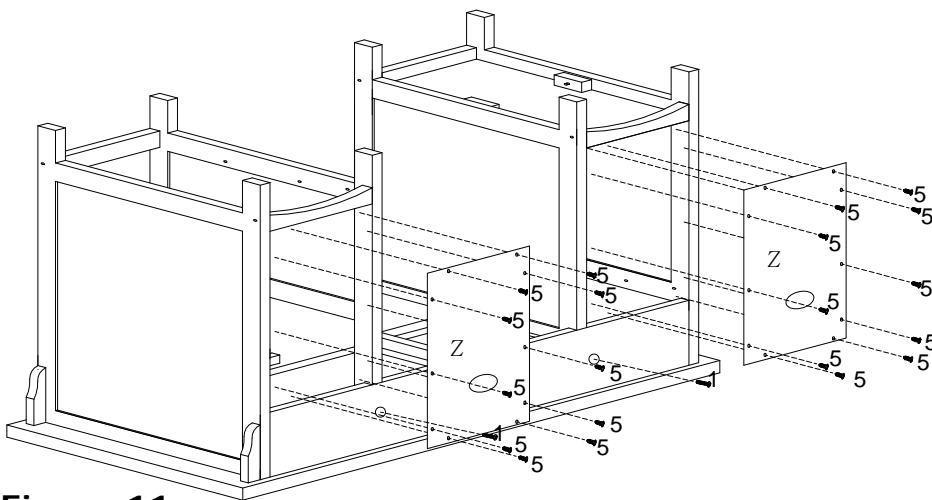

Figure 11

Connect the 2pcs Back panel (Z) to the unit with 20pcs Wood Screw (5).

Connect the Back Frame (K) with the Right/Left Partition Board (C/B) by using 2pcs Bolt (1), tighten the bolts with screwdriver.

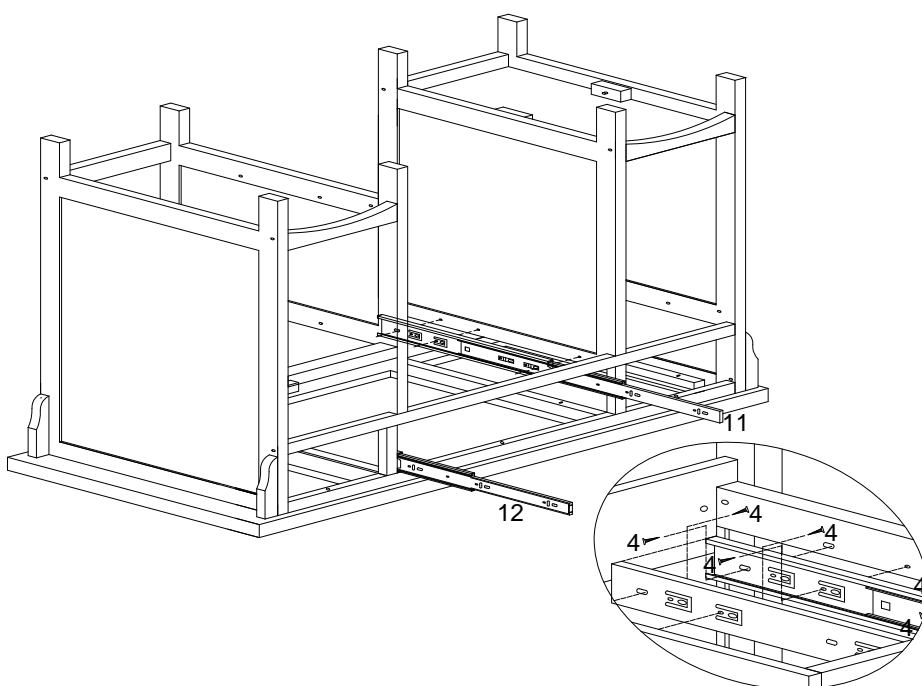

Figure 12

Attach the Left/Right extendable Glider (11&12) to the Partition Board (B/C) with 6pcs Wood Screws (4) by using the screwdriver.

Mission Computer Desk Assembly Instructions

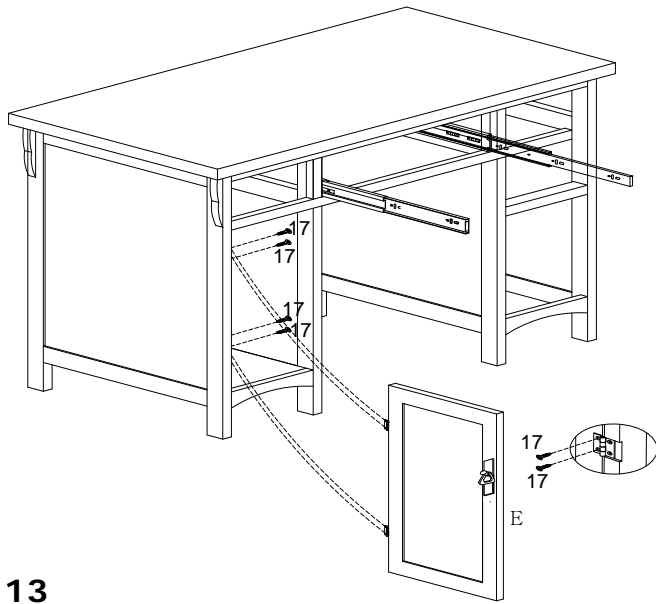

Figure 13

Connect the Door (E) with the Left Side Panel (D) by using 4pcs Wood Screw (17), tighten the screws with screwdriver.

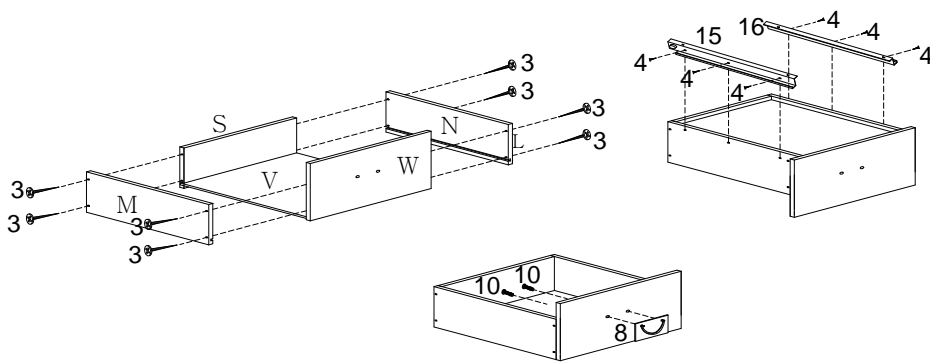

Figure 14

Assemble the small drawer (M/N/W/V/S) by using 8pcs Wood Screws (3). Attached the Right/Left Top Gliders (15&16) to the assembled drawer with 6pcs Wood Screws (4), tighten them with screwdriver. the same way to assemble the other drawer.

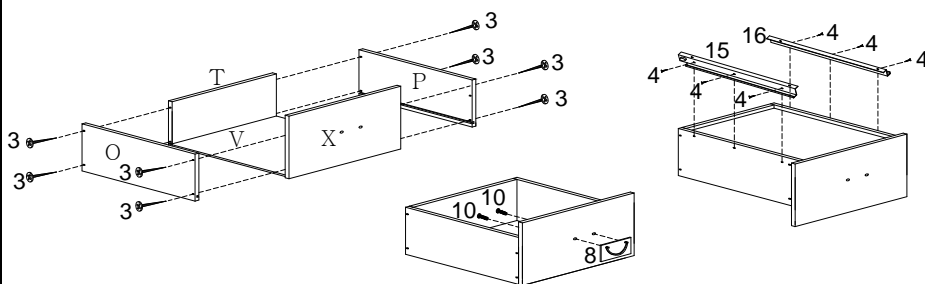
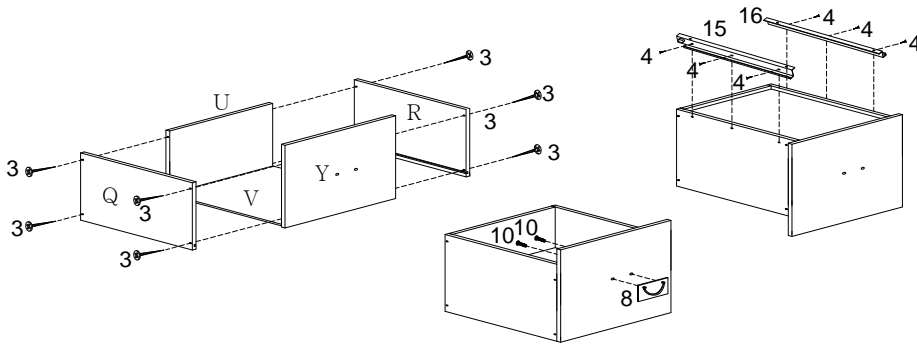

Figure 15

Assemble the Medium drawer (O/P/X/V/T) by using 8pcs Wood Screws (3). Attach the Right/Left Top Gliders(15&16) to the drawer sides with 6pcs Wood Screws (4), tighten them with screwdriver.

Mission Computer Desk Assembly Instructions



Assemble the big drawer (Q/R/Y/V/U) by using 8pcs Wood Screws (3), then attached the Right/Left Top Gliders(15&16) to the drawer sides with 6pcs Wood Screws (4), tighten them with screwdriver

Figure 16

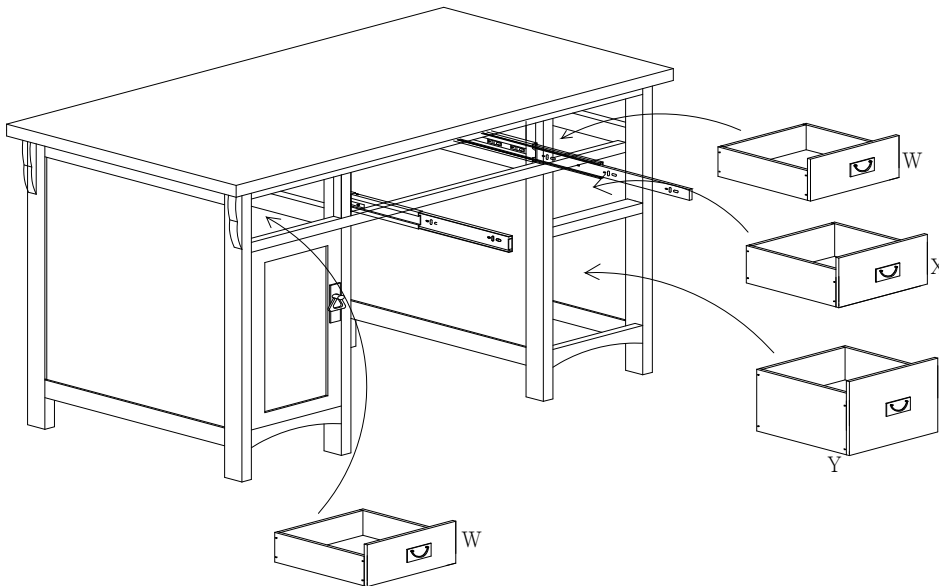

Put the Drawers into the right position.

Figure 17

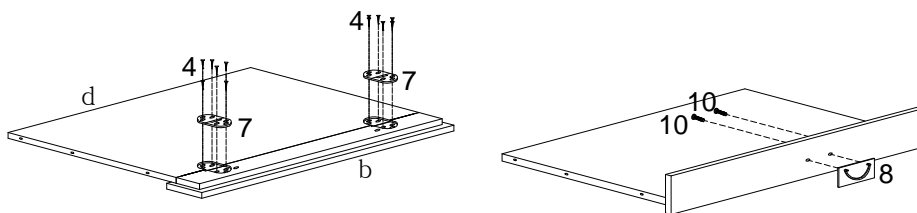

Assemble the Keyboard drawer (d/b) by using 2pcs Hinge (7) and 12pcs Wood Screw (4) by using screwdriver.

Fix the Handle (8) to the Drawer Front (b) with 2pcs Bolt (10) by using the Screwdriver.

Figure 18

Mission Computer Desk Assembly Instructions

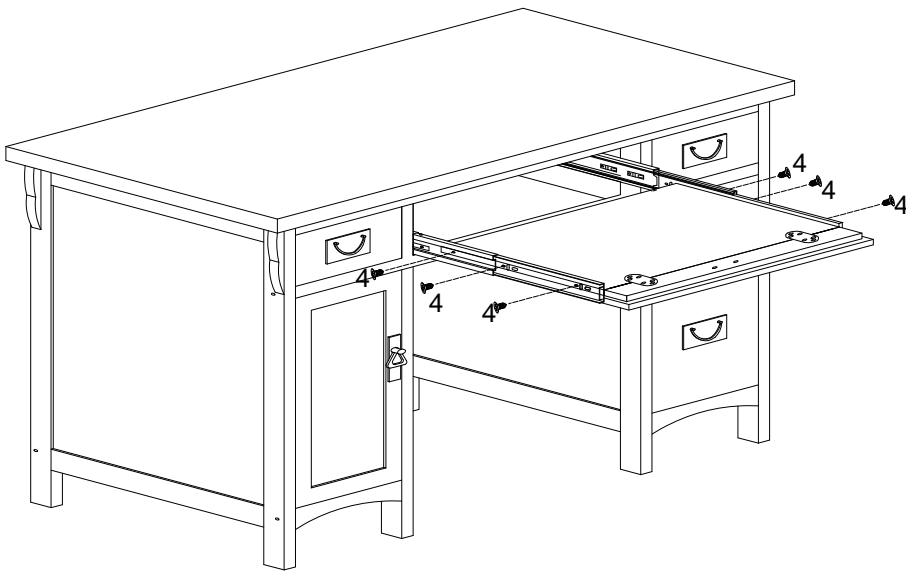

Figure 19

Attach the Keyboard Drawer to the unit with 6pcs Wood Screw (4), tighten by using Screwdriver.

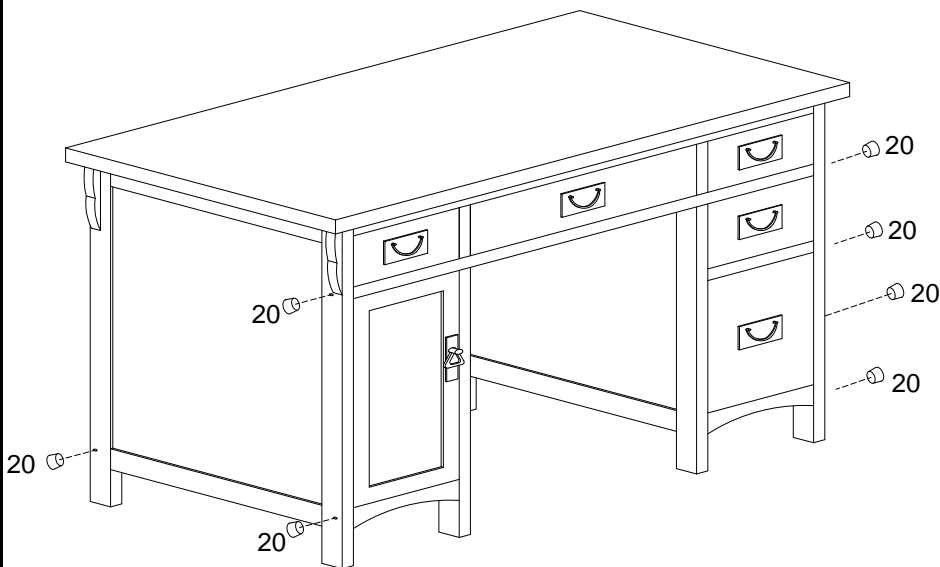

Figure 20

Insert 7pcs Wood Plugs (20) to the Left and Right Side Panel to Cover the holes.



Customer Service 1-800-633-5096

Southern Enterprises Inc.
2915 Merrell Road
Dallas, Texas 75229

HO8808 - Parts Replacement Form

Customer Information

Name _____

Address _____

City/State/Zip Code _____

Phone Number _____

Please indicate where you purchased this item: Store/Website/Catalog

Please indicate color/size/style number:

Style No	Parts Letter	Parts Description	Quantity Needed
----------	--------------	-------------------	-----------------

Missing or damaged hardware and/or parts will be replaced free of charge. We do not sell parts. Southern Enterprises Inc. will provide replacement parts for only those items purchased within the last 9 months. If this product has not been purchased from our retail affiliates (within 9 months), we are under no obligation to provide parts or replacement merchandise. Parts will not be available for items arriving fully assembled.