

BC925700TX
CAPISTRANO 2-DRAWER
BENCH-ESPRESSO
Assembly Instruction

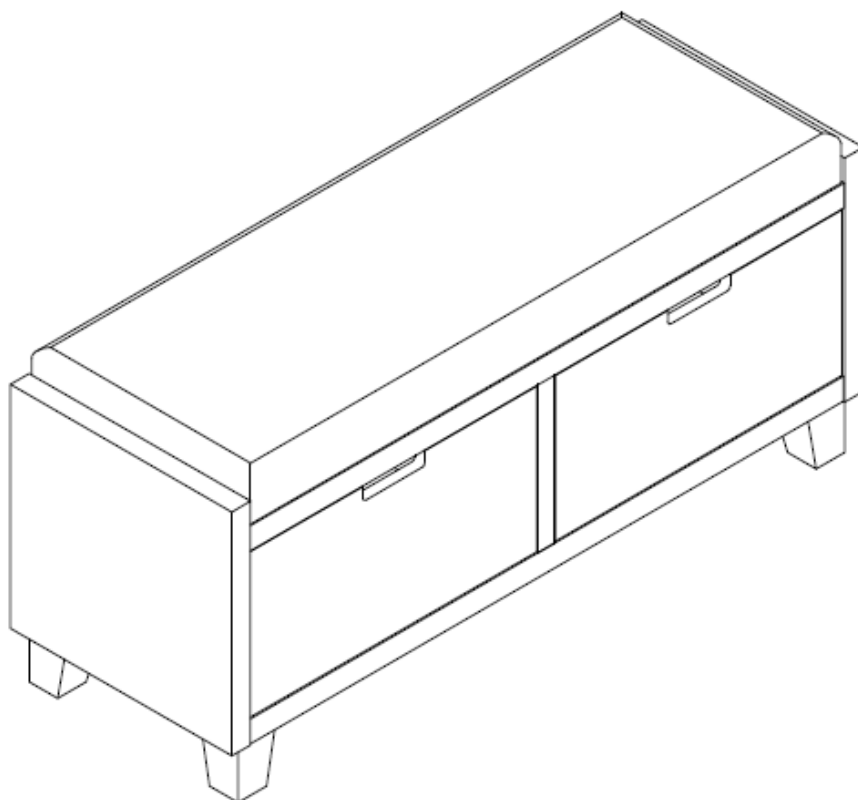

For assistance with assembly contact:
Southern Enterprises Inc.
Customer Service 1-800-633-5096
service@seidal.com
www.seidal.com



BC925700TX











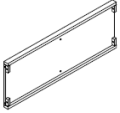
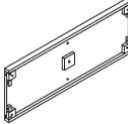
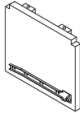
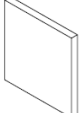

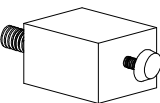
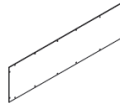
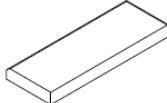

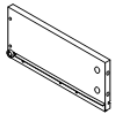
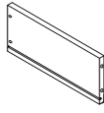
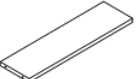

CAPISTRANO 2-DRAWER BENCH

Parts List

Please review all parts and hardware before disposing of any packaging. Call Customer Service if missing hardware. Do not return to store/retailer.

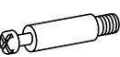
Using a screw that is too long will cause damage. Before beginning assembly, separate each type of screw. Carefully study the screw diagrams below.

You may receive extra hardware with your unit.

A  Wood Top	Quantity Of 1	B  Bottom Panel	Quantity Of 1	C  Middle Panel	Quantity Of 1
D  Left Side Panel	Quantity Of 1	E  Right Side Panel	Quantity Of 1	F  Leg	Quantity Of 4
G  Center Support Leg	Quantity Of 1	H  Back Panel	Quantity Of 1	I  Cushion	Quantity Of 1
J  Drawer Front Pane	Quantity Of 2	K  Drawer Left Side Panel	Quantity Of 2	L  Drawer Right Side Panel	Quantity Of 2
M  Drawer Back Panel	Quantity Of 2	N  Drawer Bottom Panel	Quantity Of 2	1  Bolts 1/4"x1-1/8"	Quantity Of 12
2  Lock Washer 1/4"	Quantity Of 12	3  Flat washer 1/4"x3/4"	Quantity Of 12	4  Dowel 5/16" x1-1/4"	Quantity Of 8
5  Bolt 1/4"x 2-3/4"	Quantity Of 8	6  Screw 1/8"x1/2"	Quantity Of 17	7  Cam Bolt 1/4"x1-1/8"	Quantity Of 8
8  Cam Lock 1/2"x3/8"	Quantity Of 8	9  Screw 5/32"x1"	Quantity Of 8	10  Wrench 1/4"	Quantity Of 1

Care and Cleaning Instructions:

Before using, wipe with a clean, dry cloth. Periodically apply furniture wax to renew the finish. Avoid rubbing or scratching the surface with rough or abrasive objects.

For replacement parts or questions, please call Customer Service at 1-800-633-5096. Do not return product to store. Please call manufacturer for assistance, questions or parts.

Assembly Tool Required
No.2 Phillips Screw Driver

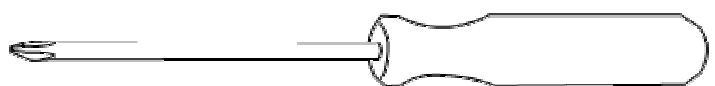

BC925700TX

CAPISTRANO 2-DRAWER BENCH

Assembly Instruction

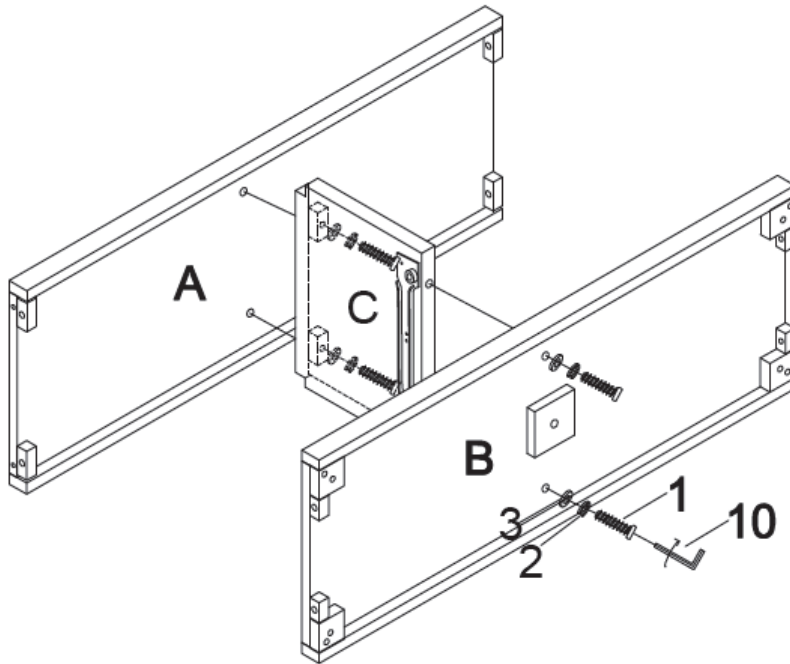

Step 1:

. PLEASE DO NOT OVER-TIGHTEN
CAMBOLTS. PLEASE STOP WHEN
YOU FEEL TIGHT

Attached top panel (A) and
Bottom Panel(B) to Middle
Panel (C) by using 4pcs bolt
(1), and 4pcs Lock Washer
(2), 4pcs Flat washer
(3) ,Wrench(10) as shown.

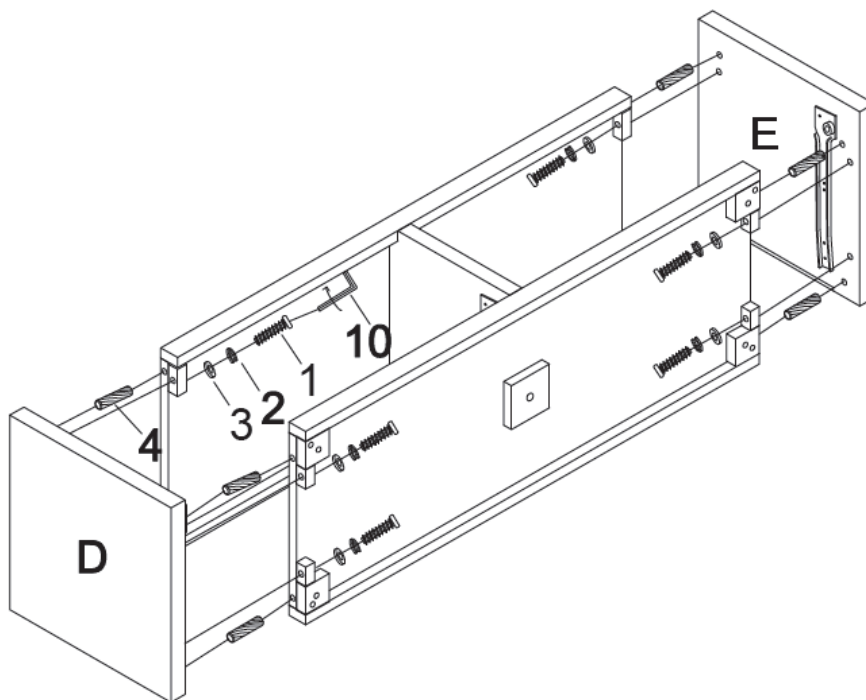

Step 2:

Attached Side panel (D/E) to
top panel (A) and Bottom
Panel(B)by using 8pcs bolt
(1), and 8pcs Lock Washer (2)
8pcs Flat washer
(3) ,Wrench(10) , 8pcs dowel
(4) as shown.

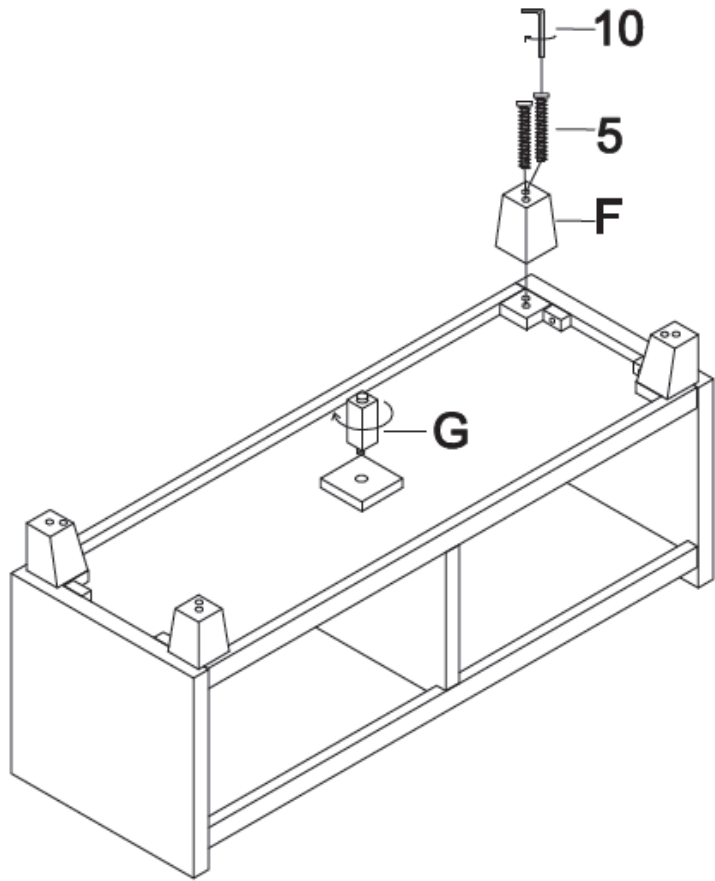

Step 3:

Attached Leg (F) to Bottom panel (B) by using 8pcs bolt (5), Wrench(10) as shown.

Please kindly make sure Leg (F) are in correct position before tighten all bolt(5).

Assemble Center Support Leg(G) to Bottom panel

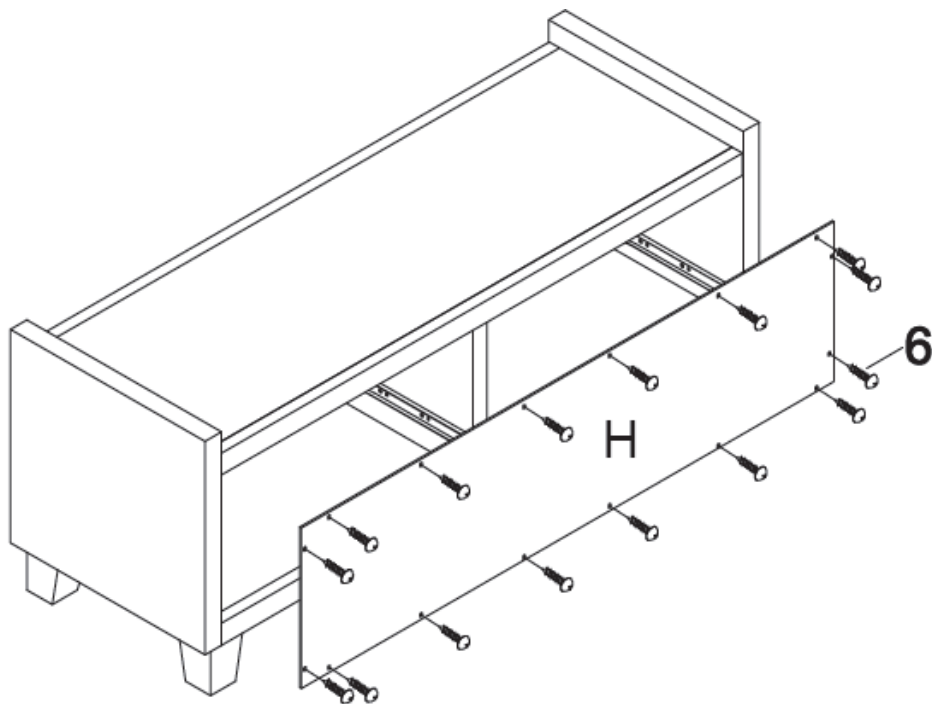

Step 4:

Attach back panel (H) to the back of frame by using 17 pcs screw (6) as shown.

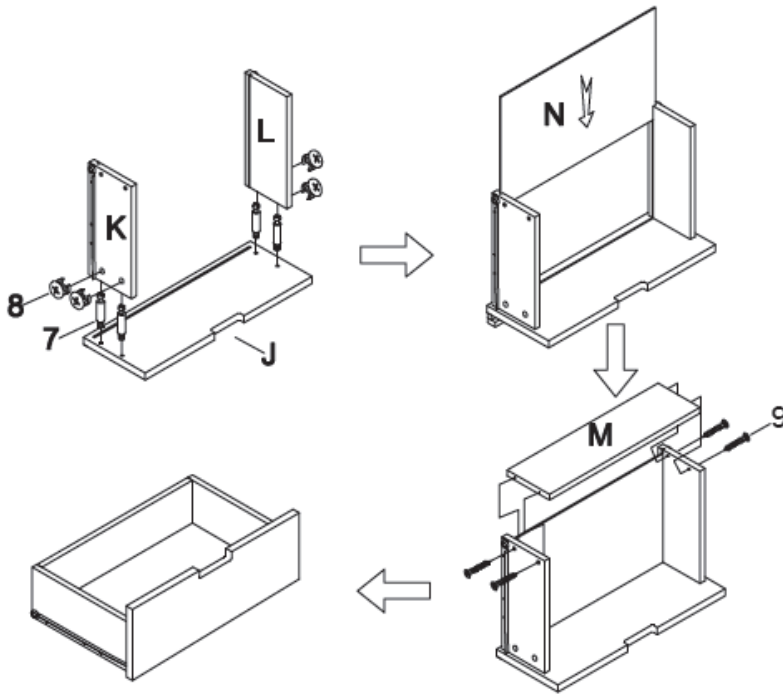

Step 5:

Attached drawer left side panel (K) and drawer right side panel (L) to drawer front panel (J) by using 8pcs cam bolt (7) and , 8pcs cam lock (8) as shown.

Then insert drawer bottom panel (N) into the groove of . panels (J) (K) (L).

Attached drawer back panel (M) to drawer body by using 8pcs screw (9) as shown.

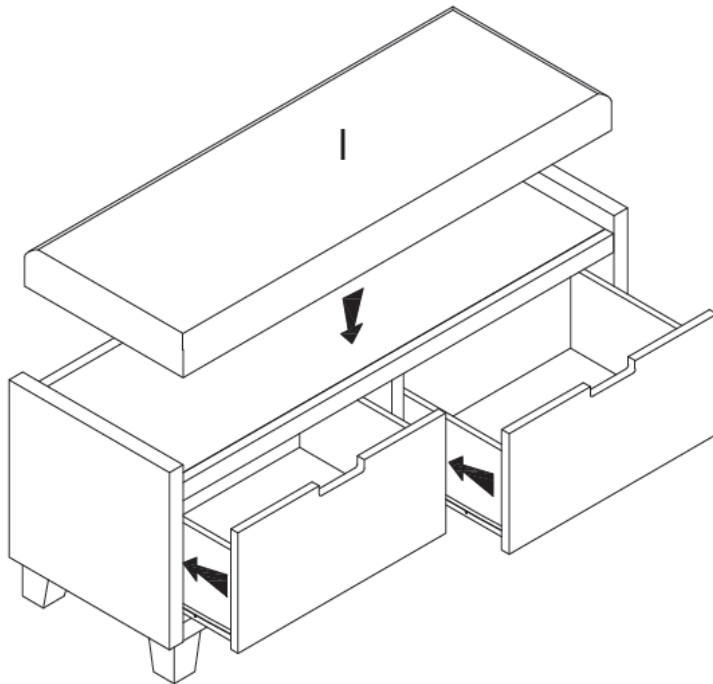

Step 6:

Insert the drawer as shown.

Put the cushion (I) onto top panel (A).

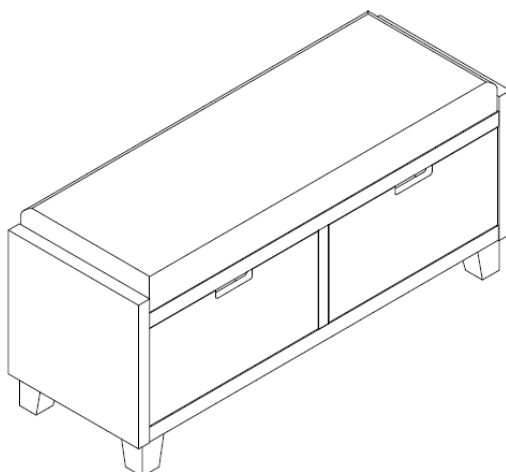

MAX LOADING WEIGHT FOR SEAT CUSHION (I) IS 250LBS.
MAX LOADING WEIGHT FOR EACH DRAWER BOX IS 15LBS

Parts Replacement Form

Customer Information

Name _____

Address _____

City/State/Zip Code _____

Phone Number _____

Please indicate where you purchased this item: Store/Website/Catalog

Please indicate color/size/style number:

Style No

Parts Letter

Parts Description

Quantity Needed

Style No	Parts Letter	Parts Description	Quantity Needed
_____	_____	_____	_____
_____	_____	_____	_____
_____	_____	_____	_____

Please immediately examine this product carefully. Any request for missing parts or damage replacement must be received within 90 days of your receipt of the product. Replacement, if available, will be honored within this time frame. Parts will not be available for items arriving fully assembled. We do not recommend modifying product(s) and we are not responsible for any damages due to product modification(s). If damages or missing parts are not reported within 90 days of your receipt, we are under no obligation to provide parts or replacement merchandise.

Please contact Southern Enterprises at 800-633-5096 or in Dallas 972-869-0111/ 9am – 4pm Mon-Fri Central time if you have product issues or email us at service@seidal.com. Please ask for customer service representative for issues involving damages or replacement parts. Please ask for technical assistance representative for any issues with product and assembly/construction.

Please contact the retailer that you purchased from for returns.



Customer Service

1-800-633-5096

service@seidal.com

Southern Enterprises, Inc.

600 Freeport Parkway, Suite 200