

**BC401700TX**

**Loring Entryway Storage Bench**

**Assembly Instructions**



**Southern**  
ENTERPRISES

For assistance with assembly contact:  
Southern Enterprises, Inc.  
Customer Service 1-800-633-5096  
service@seidal.com  
www.seidal.com



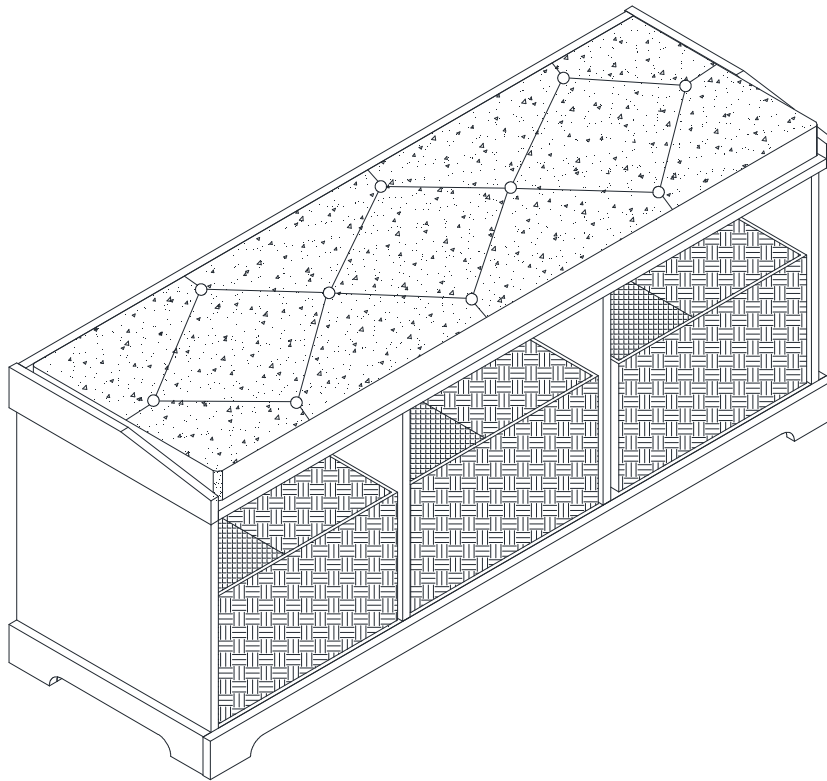



PO#:

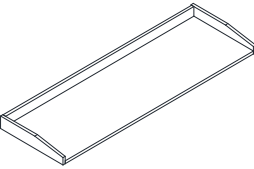
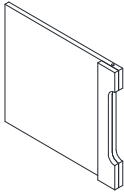
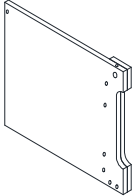
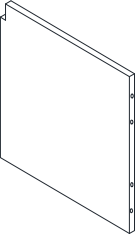
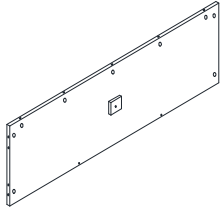
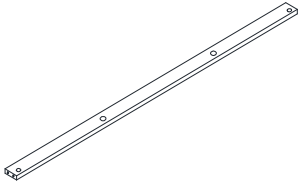
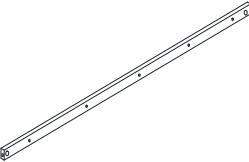
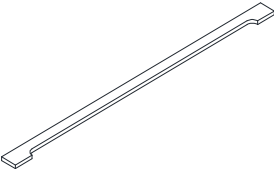
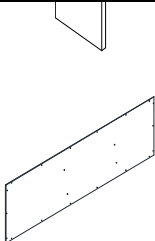
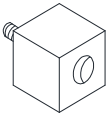
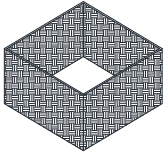
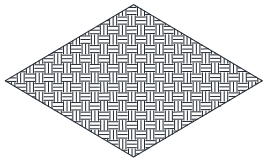

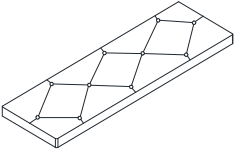
# Loring Entryway Storage Bench Parts List

Please check packaging for all parts and hardware before discarding. Unpack and lay parts on clean, padded surface like carpet or blanket. Check that you have all parts indicated. Call customer service if hardware is missing. Before beginning assembly, carefully study the diagrams below and sort your hardware according to the pictures. Using the incorrect hardware will cause damage.

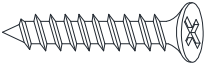
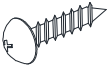
<p><b>A</b> Quantity of 1</p>  <p>Top Panel</p>	<p><b>B</b> Quantity of 1</p>  <p>Left Side Panel</p>	<p><b>C</b> Quantity of 1</p>  <p>Right Side Panel</p>
<p><b>D</b> Quantity of 2</p>  <p>Middle Panel</p>	<p><b>E</b> Quantity of 1</p>  <p>Bottom Panel</p>	<p><b>F</b> Quantity of 1</p>  <p>Rear Cross Panel</p>
<p><b>G</b> Quantity of 1</p>  <p>Front Cross Panel</p>	<p><b>H</b> Quantity of 1</p>  <p>Front Apron Panel</p>	<p><b>I</b> Quantity of 1</p>  <p>Back Panel</p>
<p><b>J</b> Quantity of 1</p>  <p>Center Support Leg</p>	<p><b>K</b> Quantity of 3</p>  <p>Wicker Frame</p>	<p><b>L</b> Quantity of 3</p>  <p>Wicker Bottom</p>

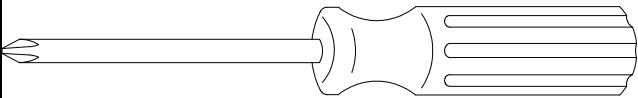
<p><b>M</b></p> <p>Quantity of 1</p>  <p>Cushion</p>		
<p><b>1</b></p> <p>Quantity of 29</p>  <p>Cam Bolt</p>	<p><b>2</b></p> <p>Quantity of 29</p>  <p>Cam Lock</p>	<p><b>3</b></p> <p>Quantity of 18</p>  <p>Wood Dowel Ø5/16"x1-1/2"L</p>
<p><b>4</b></p> <p>Quantity of 5</p>  <p>Screw</p> <p>Ø5/32"x1"L</p>	<p><b>5</b></p> <p>Quantity of 22</p>  <p>Screw</p> <p>Ø1/8"x1/2"L</p>	<p><b>6</b></p> <p>Quantity of 12</p>  <p>Adhesive Pad</p>
<p><b>Care and Cleaning Instructions:</b>          Before using, wipe with a clean, dry cloth. Periodically apply furniture wax to renew the finish. Avoid rubbing or scratching the surface with rough or abrasive objects.</p>		<p>For replacement parts or questions, please Call Customer Service at 1-800-633-5096.</p>
<p><b>Assembly Tool Required          No.2 Phillips Screwdriver          (Not Included)</b></p>		

# LORING ENTRYWAY STORAGE BENCH

## Assembly Instructions

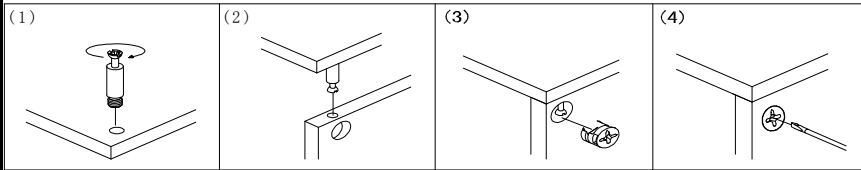

"Please do not over tighten cam bolts, please stop when you feel them tighten"

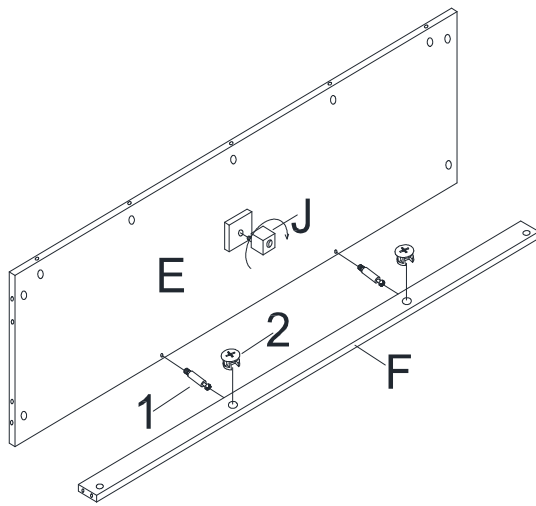

Figure 1

Insert cam locks (2) into holes on back cross Panel (F).

Screw cam bolts (1) into holes on bottom panel (E).

Attach rear cross panel (F) to bottom panel (E) by inserting cam bolts (1) into corresponding holes until panels meet.

Tighten by rotating cam locks (2) clockwise with Phillips screwdriver.

Attach center support leg (J) to the bottom panel (E) by hand.

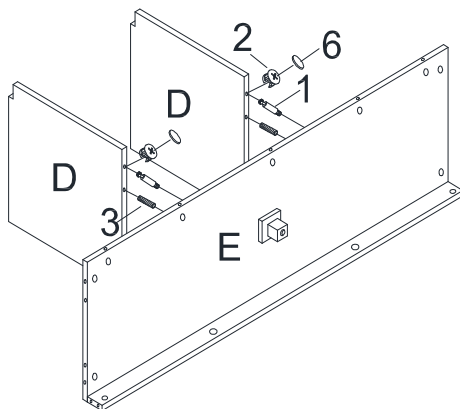

Figure 2

Insert cam locks (2) into holes on middle panel (D).

Screw cam bolts (1) into holes on bottom panel (E).

Attach middle panel (D) to bottom panel (E) by inserting cam bolts (1) and wood dowels (3) into corresponding holes until panels meet.

Tighten by rotating cam locks (2) clockwise with Phillips screwdriver.

Cover cam locks (2) with adhesive pads (6) provided.

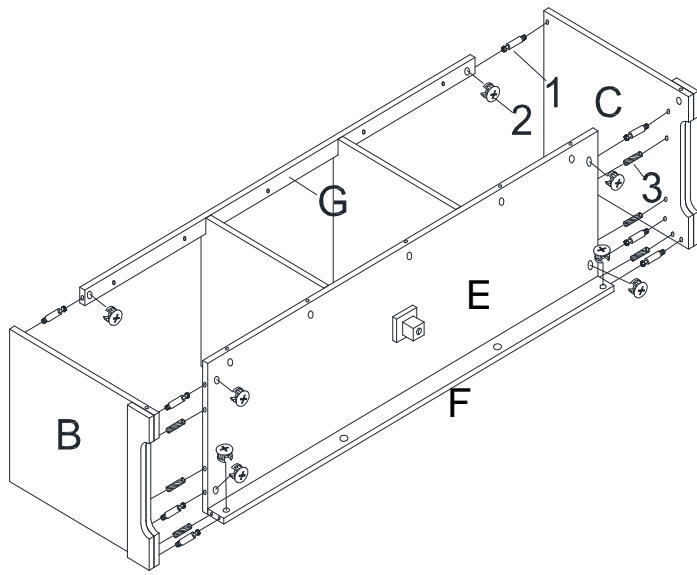

**Figure 3**

Insert cam locks (2) into holes on bottom panel (E), rear cross panel (F), and front cross panel (G).

Screw cam bolts (1) into holes on side panels (B) and (C).

Attach side panels (B) and (C) to bottom panel (E), rear cross panel (F), and front cross panel (G) by inserting cam bolts (1) and wood dowels (3) into corresponding holes until panels meet.

Tighten by rotating cam locks (2) clockwise with Phillips screwdriver.

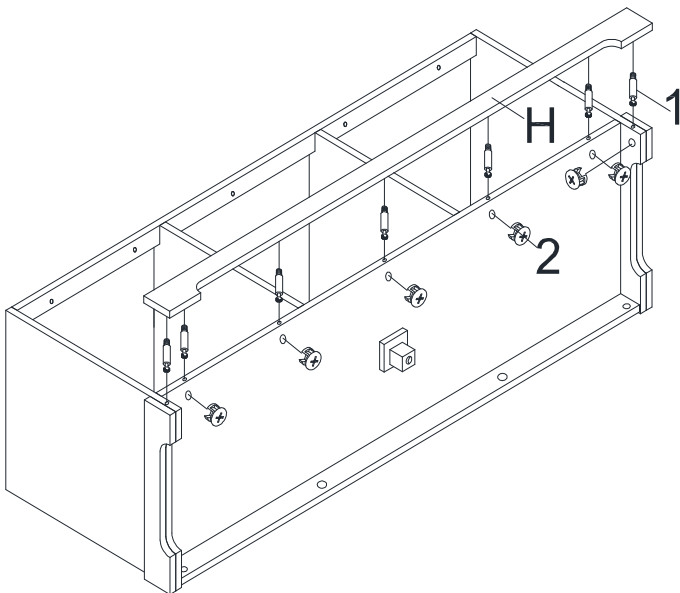

**Figure 4**

Insert cam locks (2) into holes on assembled unit as shown.

Screw cam bolts (1) into holes on front apron panel (H).

Attach front apron panel (H) to assembled unit by inserting cam bolts (1) into corresponding holes until panels meet.

Tighten by rotating cam locks (2) clockwise with Phillips screwdriver.

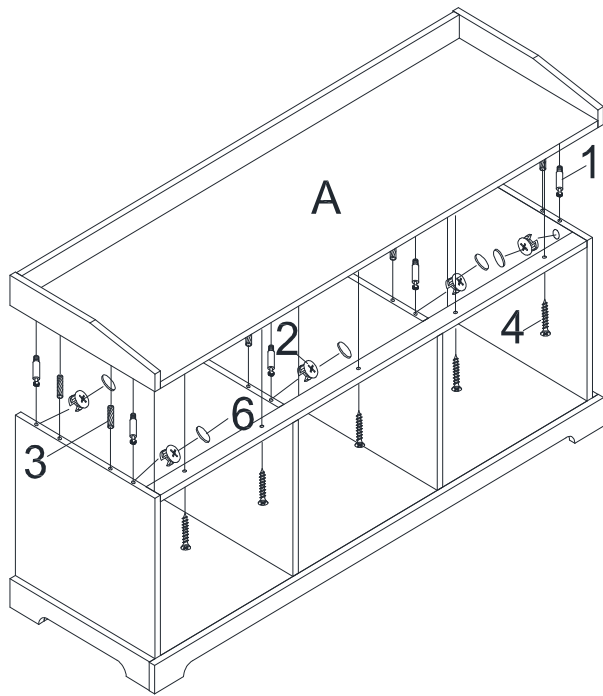

**Figure 5**

Insert cam locks (2) into holes on assembled unit as shown.

Screw cam bolts (1) into holes on top panel (A).

Attach top panel (A) to assembled unit by inserting wood dowels (3), cam bolts (1), and screws (4) into corresponding holes until panels meet.

Tighten by rotating cam locks (2) and screws (4) clockwise with Phillips screwdriver.

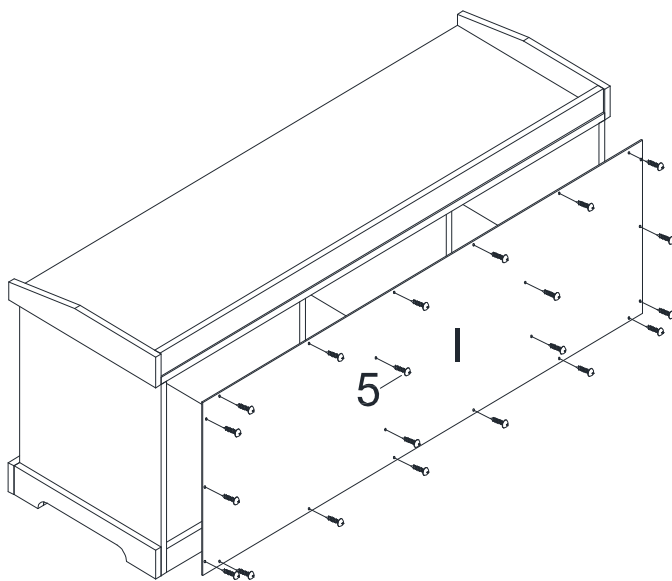

**Figure 6**

Attach back panel (l) to assembled unit with screws (5).

Tighten screws (5) with Phillips screwdriver.

Attach the wicker bottoms (L) to wicker frames (K).

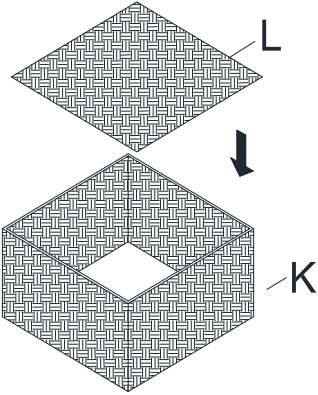

Figure 7

Place wicker baskets into the assembled unit.

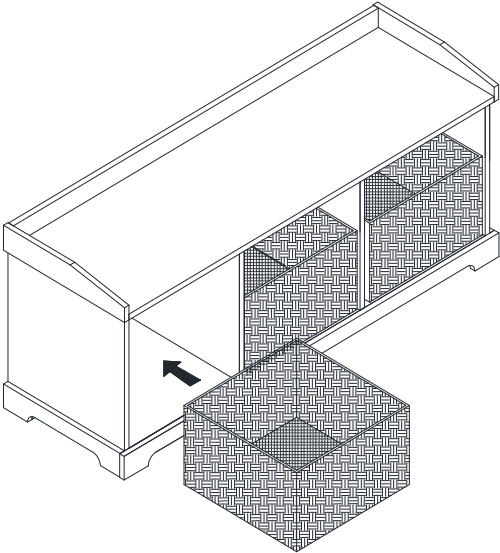
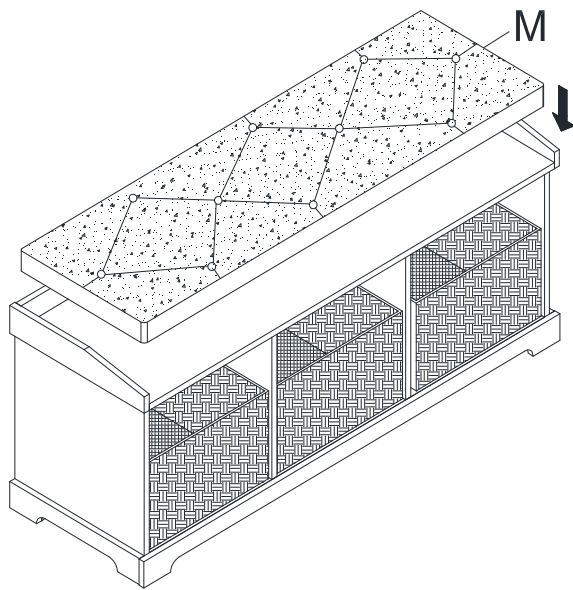
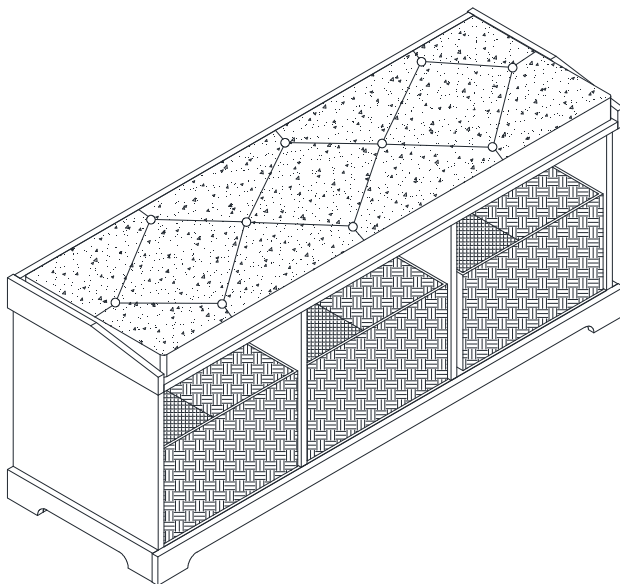

Figure 8



Place the cushion (M) onto top panel (A).

**Figure 9**



Now your Loring entryway storage bench is ready to use.

**Figure 10**



# Parts Replacement Form

## Customer Information

Name \_\_\_\_\_

Address \_\_\_\_\_

City/State/Zip Code \_\_\_\_\_

Phone Number \_\_\_\_\_

Please indicate where you purchased this item: Store/Website/Catalog

\_\_\_\_\_

Please indicate color/size/style number:

\_\_\_\_\_

Style No	Parts Letter	Parts Description	Quantity Needed
_____	_____	_____	_____
_____	_____	_____	_____
_____	_____	_____	_____

Please immediately examine this product carefully. Any request for missing parts or damage replacement must be received within 90 days of your receipt of the product. Replacement, if available, will be honored within this time frame. Parts will not be available for items arriving fully assembled. We do not recommend modifying product(s) and we are not responsible for any damages due to product modification(s). If damages or missing parts are not reported within 90 days of your receipt, we are under no obligation to provide parts or replacement merchandise.

Please contact Southern Enterprises at 800-633-5096 or in Dallas 972-869-0111/ 9am – 4pm Mon-Fri Central time if you have product issues or email us at [service@seidal.com](mailto:service@seidal.com). Please ask for customer service representative for issues involving damages or replacement parts. Please ask for technical assistance representative for any issues with product and assembly/construction.

Please contact the retailer that you purchased from for returns.



**Southern**  
ENTERPRISES

Customer Service 1-800-633-5096  
[service@seidal.com](mailto:service@seidal.com)  
Southern Enterprises, Inc.  
600 Freeport Parkway, Suite 200  
Coppell, Texas 75019