

"GRANBURY" BENCH

BC9377R0TX-DISTRESSED ANTIQUE BLACK

BC9376R0TX-DISTRESSED ANTIQUE WHITE

Assembly Instructions



For assistance with assembly contact:
Southern Enterprises Inc.

Customer Service 1-800-633-5096

service@seidal.com

www.seidal.com



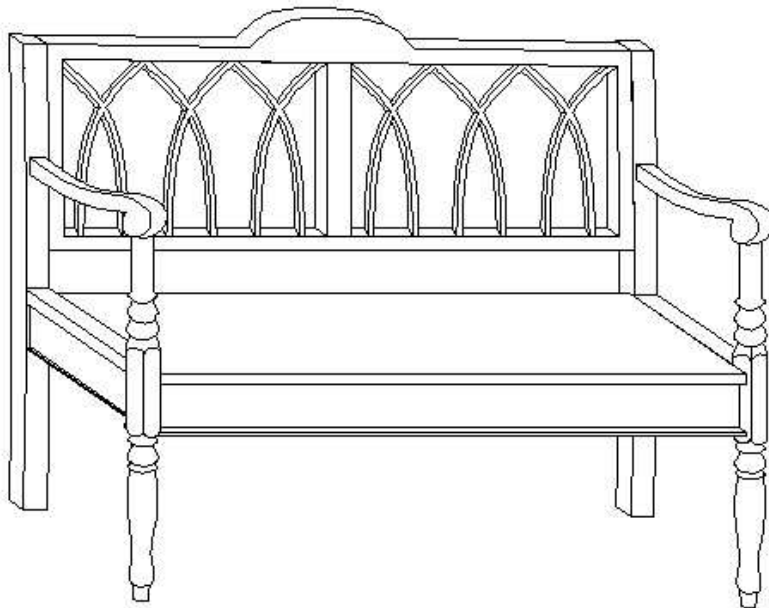



PO#12372

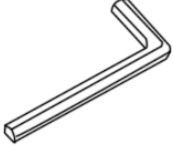
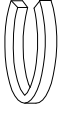

GRANBURY" BENCH

Parts List

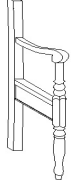
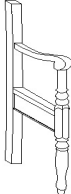
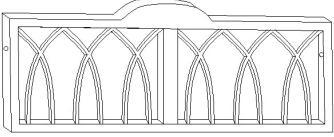
Please review all parts and hardware before disposing of any packaging. Call Customer Service if missing hardware. Do not return to store/retailer. Using a screw that is too long will cause damage. Before beginning assembly, separate each type of screw. Carefully study the screw diagrams below. You may receive extra hardware with your unit.

<p>A</p>  <p>Quantity of 4</p> <p>1/4"x1-3/4" BOLT</p>	<p>B</p>  <p>Quantity of 8</p> <p>1/4"x1-1/2" BOLT WITH WASHER</p>
<p>C</p>  <p>Quantity of 4</p> <p>WOOD PLUG</p>	<p>D</p>  <p>Quantity of 1</p> <p>ALLEN WRENCH</p>
<p>E</p>  <p>Quantity of 8</p> <p>Lock washer 1/4"</p>	<p>F</p>  <p>Quantity of 8</p> <p>Flat washer 1/4"x3/4"</p>
<p>G</p>  <p>Quantity Of 4</p> <p>Dowel 5/16" x1-1/4"</p>	
<p>(1)</p>  <p>Quantity of 1</p> <p>LEFT SIDE FRAME</p>	<p>(2)</p>  <p>Quantity of 1</p> <p>RIGHT SIDE FRAME</p>
<p>(3)</p>  <p>Quantity of 1</p> <p>BACK PANEL</p>	<p>(4)</p>  <p>Quantity of 1</p> <p>SEAT PANEL</p>
<p>Care and Cleaning Instructions: Before using, wipe with a clean, dry cloth. Periodically apply furniture wax to renew the finish . Avoid rubbing or scratching the surface with rough or abrasive objects.</p>	<p>For replacement parts or questions, please Call Customer Service at 1-800-633-5096 Do not return product to store, please call Manufacturer for assistance, questions or Parts.</p>

Assembly Tool Required
No.2 Phillips Screw Driver

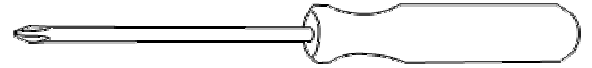

GRANBURY" BENCH Assembly Instructions

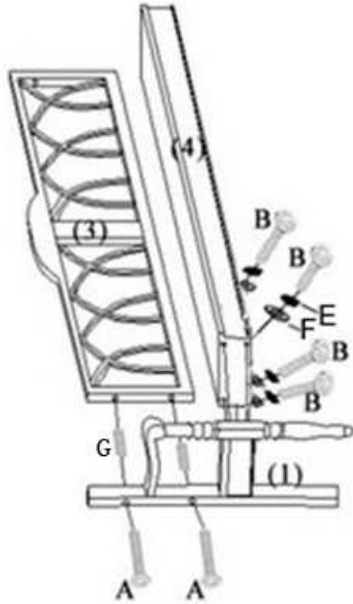

Figure 1

Assembly Instructions:

Wood may scratch easily. Be careful when assembling. Do not scratch.

Step 1. Unpack and lay parts on clean, padded surface like carpet or blanket. Check that you have all parts indicated on the front page.

Step 2. Attach the Left Side Frame (1) to the Back Panel (3) and Seat Panel (4) by using 2pcs Bolt (A) and 4pcs bolt with washer (B) and flat washer (F) and lockwasher (E). Wood Dowels (G) Tighten with Allen Wrench (D).

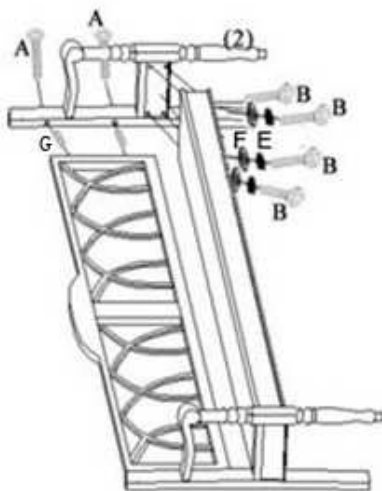
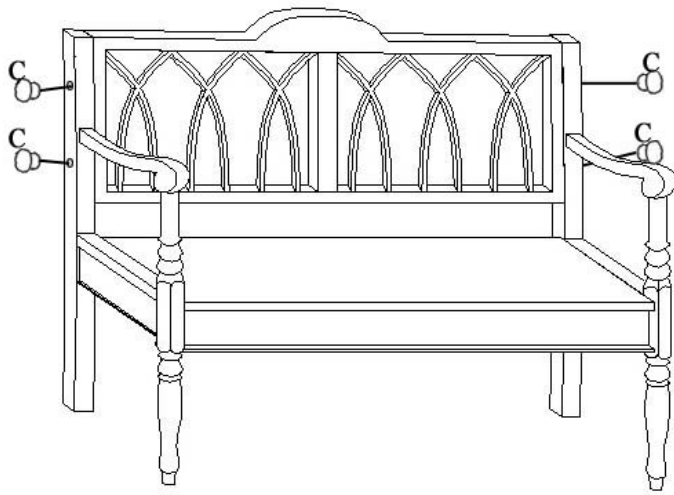

Figure 2

The same way as Figure 1 to attach the Right Side Frame (2) to the Back Panel (3) and Seat Panel (4).



Cover the holes on the Left and Right Side Frames (1&2) with the Wood Plugs.

Figure 3

Parts Replacement Form

Customer Information

Name

Address

City/State/Zip Code

Phone Number

Please indicate where you purchased this item: Store/Website/Catalog

Please indicate color/size/style number:

Style No	Parts Letter	Parts Description	Quantity Needed
----------	--------------	-------------------	-----------------

Please immediately examine this product carefully. Any request for missing parts or damage replacement must

be received within 90 days of your receipt of the product. Replacement, if available, will be honored within this time frame. Parts will not be available for items arriving fully assembled. We do not recommend modifying product(s) and we are not responsible for any damages due to product modification(s). If damages or missing parts are not reported within 90 days of your receipt, we are under no obligation to provide parts or replacement merchandise.

Please contact Southern Enterprises at 800-633-5096 or in Dallas 972-869-0111/ 9am – 4pm Mon-Fri Central time if you have product issues or email us at service@seidal.com. Please ask for customer service representative for issues involving damages or replacement parts. Please ask for technical assistance representative for any issues with product and assembly/construction.

Please contact the retailer that you purchased from for returns.



Customer Service 1-800-633-5096

service@seidal.com

Southern Enterprises, Inc.

600 Freeport Parkway, Suite 200

Coppell, Texas 75019