

60" TUB WALL KIT

Français p. 12

Español p. 23

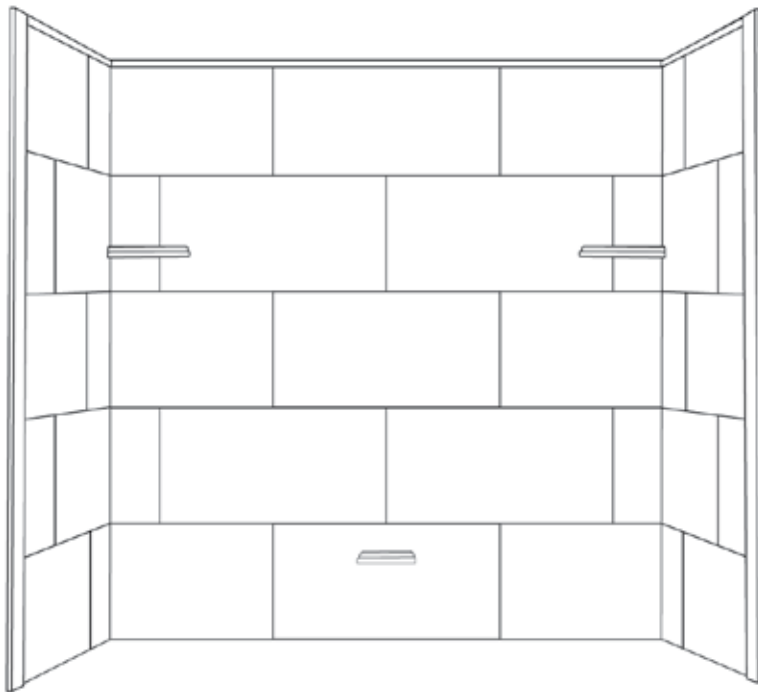

ATTACH YOUR RECEIPT HERE

Purchase Date _____

Questions, problems, missing parts? Call our customer service department at 1-877-632-6322, 8 a.m. - 8 p.m., EST, Monday - Friday, 9 a.m. - 5 p.m., EST, Saturday, 11 a.m. - 5 p.m., EST, Sunday.

PACKAGE CONTENTS

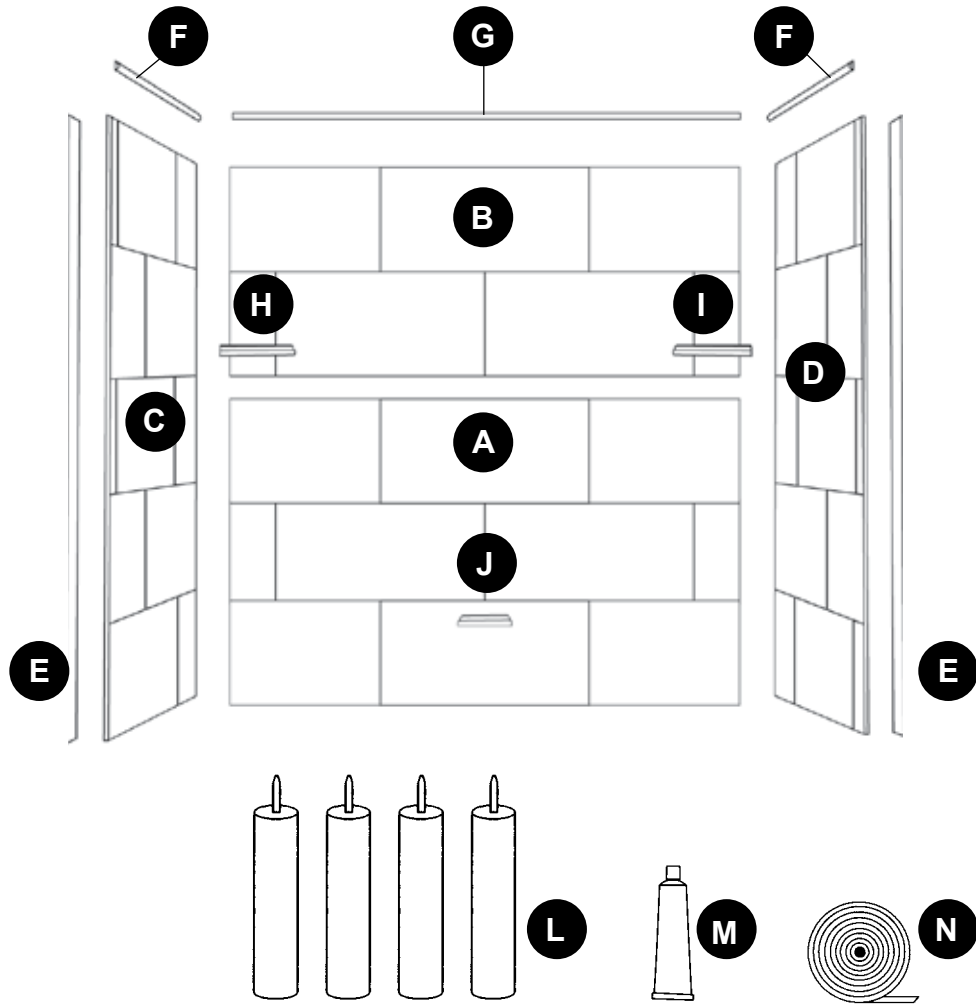

PART	DESCRIPTION	QUANTITY
A	Lower Back Panel	1
B	Upper Back Panel	1
C	Left Side Panel	1
D	Right Side Panel	1
E	Front Edge Trim	2
F	Side Bullnose Molding	2
G	Back Bullnose Molding	1
H	Left Shampoo Shelf	1
I	Right Shampoo Shelf	1
J	Soap Dish	1
L	Silicone Adhesive	4
M	Mounting Adhesive	1
N	Installation Tape	1



SAFETY INFORMATION

Please read and understand this entire manual before attempting to assemble or install the product.

WARNING

- Always wear safety glasses or eye protection when using power tools. Use a dust mask or respirator for applications that generate dust.
- DO NOT proceed if any doubt arises about the correct or safe method of performing anything found in this manual. The installation of this product can require the use of power tools. Do not use power tools without adequate training. If necessary, hire or consult a trained professional for expert assistance before continuing.

CAUTION

Use care when opening the box so that you do not damage the panels.

Store panels in a flat area to avoid warpage until the time of installation. Do not store the panels outside of the original packaging in a vertical position.

Make sure the walls are the correct size and are in good condition. Installation of damaged product will void the warranty.

PREPARATION

Before beginning assembly of product, make sure all parts are present. Compare parts with package contents list and hardware contents list. If any part is missing or damaged, do not attempt to assemble the product.

Estimated Assembly Time: 120 minutes

Tools Required for Assembly (not included): Level, Tape Measure, Pencil, Compass Scribe, Circular Saw, Sanding Block, Shims, Drill and 3/8 in. Drill Bit, 1/2 in. Hole Saw, Caulk Gun, Safety Glasses, Dust Mask, Saber Saw, Denatured Alcohol, Clean Shop Towels, Masking Tape

Helpful Tools (not included): 2 in. x 4 in. Wood Bracing

Prepare the area with moisture-resistant drywall, marine-grade plywood or tile backer board. Never install directly on any wall construction that is or may become damp. When installing over ceramic tile, check for loose tiles. If you find any, correct the problem. Make sure the area to be covered is uniform in support. If not, build up the areas without tile. Remove the bottom row of tile and cut a ventilation gap in the substrate. On every installation, make sure there is a 1/2 in. clearance between the top of the tub deck and the bottom of the substrate. This will allow for ventilation and keep water leaks from wicking up the substrate.

ASSEMBLY INSTRUCTIONS

1. LOWER BACK PANEL

Determine the width of the lower back wall panel (A) by measuring from the top of the tub deck and up 36 in. from the top of the tub. Measure the width of the opening from these points. Note: If the wall is not square, you can use cardboard (not included) to create a template of the wall and transfer the data to the lower back panel (A). The 1/4 in. extension on the lower back panel (A) is at the top of the panel.

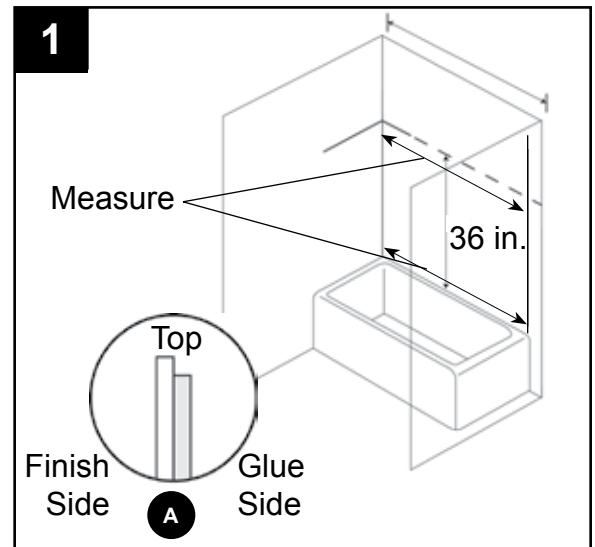

2. Check the measurements, and then place masking tape (not included) over the area where the saw (not included) will contact the finished side of the lower back panel (A). Cut the lower back panel (A), and make any final adjustments to the cuts with a sanding block (not included).

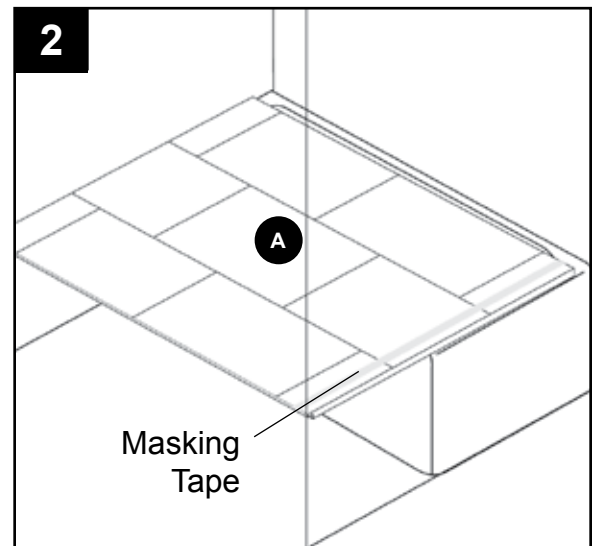

3. If needed, place 1/16 in. thick shims (not included) at the base of the lower back panel's (A) installation site. Trial fit the lower back panel (A) on the shims and use a sanding block if any fine adjustments are needed. Remove lower back panel (A) from wall and clean the back of the lower back panel (A), the wall board and any other area that will be in contact with the silicone (L) with denatured alcohol and a clean rag (both not included).

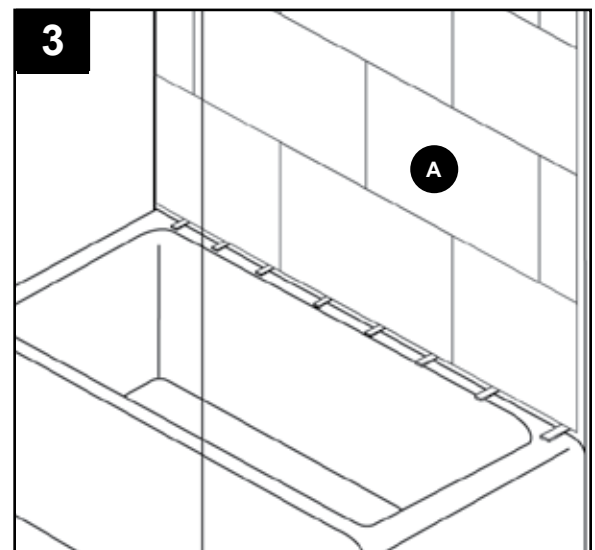

ASSEMBLY INSTRUCTIONS

4. Cut eleven 4-in. strips of installation tape (N) and place them on lower back panel (A) where indicated in figure 4. Apply silicone adhesive (L) in 3/4 in. diameter dots every 6-7 in. apart over the surface of the reinforcement strips on the back of lower back panel (A). Place the lower back panel (A) in place and press firmly.

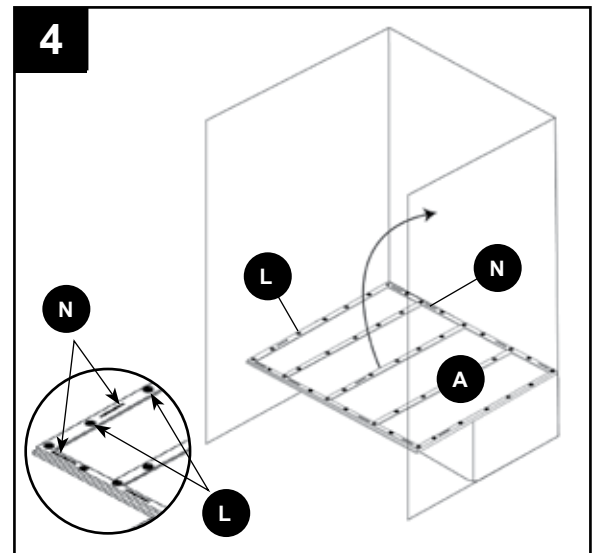

5. UPPER BACK PANEL

Determine the width of the upper back wall panel (B) by measuring from the top of the lower back panel (A) and 24 in. up from the top of the lower wall panel (A). Repeat steps 1 and 2 for upper back panel (B), noting the 1/4 in. extension on upper back panel (B) is at the bottom.

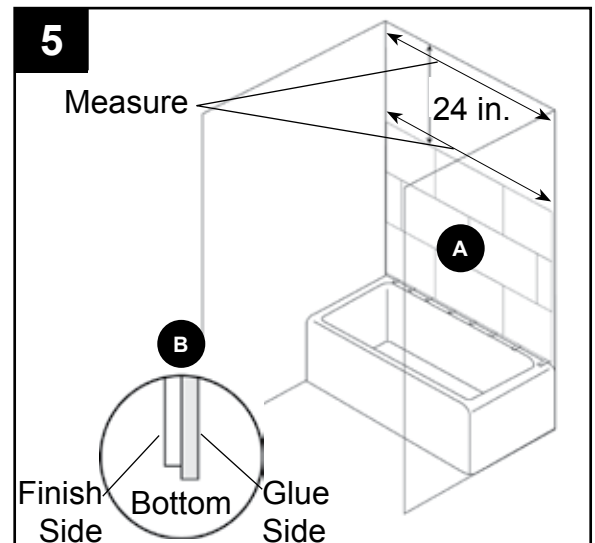

6. Trial fit the upper back panel (B) on top of the lower back panel (A) and use a sanding block (not included) if any fine adjustments are needed. Remove upper back panel (B) from the wall and clean the back of the upper back panel (B), the wall board and any other area that will be in contact with the silicone (K) with denatured alcohol and a clean rag (both not included).

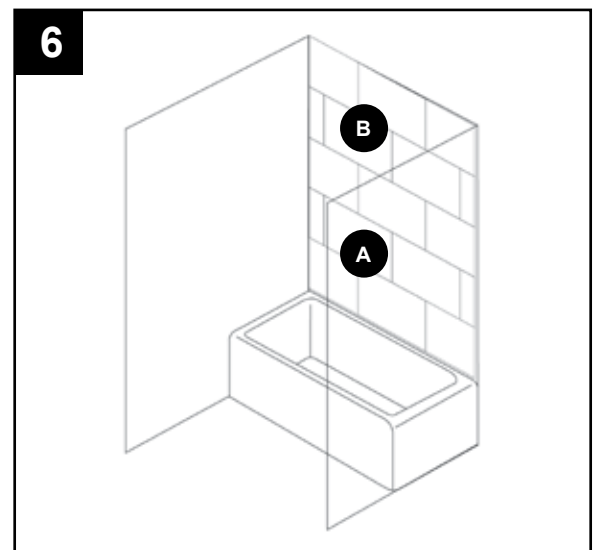

ASSEMBLY INSTRUCTIONS

7. Cut eleven 4-in. strips of installation tape (N) and place them on upper back panel (B) where indicated in figure 7. Apply silicone adhesive (L) in 3/4 in. diameter dots every 6-7 in. apart over the surface of the reinforcement strips on the back of upper back panel (B). Apply a bead of silicone adhesive (L) into the area where the lower back panel (A) and upper back panel (B) connect. Place the upper back panel (B) into the lower back panel (A) and press firmly together and against the substrate.

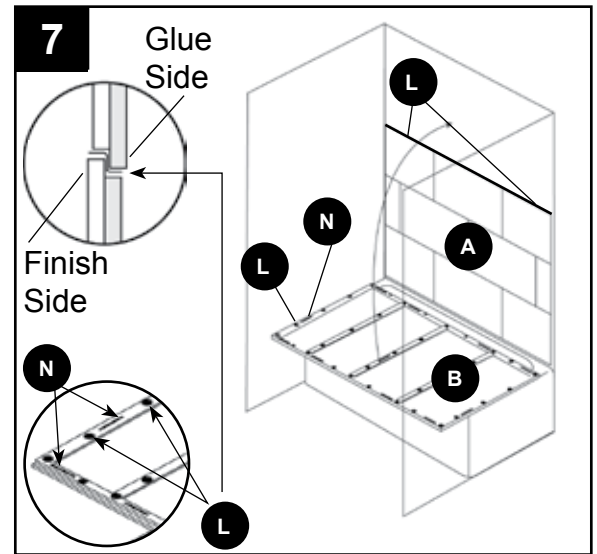

8. SIDE PANEL

Measure from the back wall at the top and the bottom of the back panel assembly to the edge of the tub deck. The front edge trim (E) extends the left side panel (C) and right side panel (D) width by a minimum of 1/2 in. to a maximum of 1-1/2 in., so the left side panel (C) and right side panel (D) width needs to be cut a minimum of 1/2 in. shorter than your desired finished side wall dimension. Note: If the wall is not square, you can use cardboard to create a template of the wall and transfer the data to the left side panel (C) and right side panel (D). Be certain to use left side panel (C) on the left side of the installation site and right side panel (D) on the right side to ensure proper tile pattern layout.

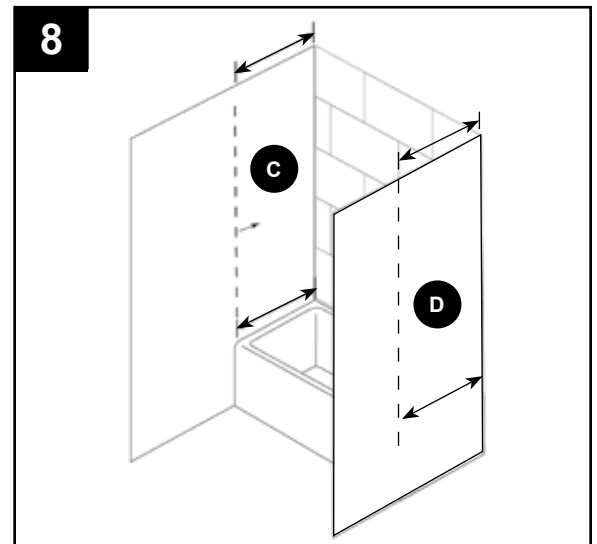

9. If no plumbing holes exist on side panel, proceed to step 10. Locate the locations of the plumbing holes and transfer the data to either left side panel (C) or right side panel (D). Cut the holes a minimum of 1/4 in. larger than the pipe diameters. Note: To avoid possible breakage, all inside corners of cutouts should have a minimum 1/4 in. radius. Use masking tape (not included) to protect the area where the cutting tool will contact the finished surface.

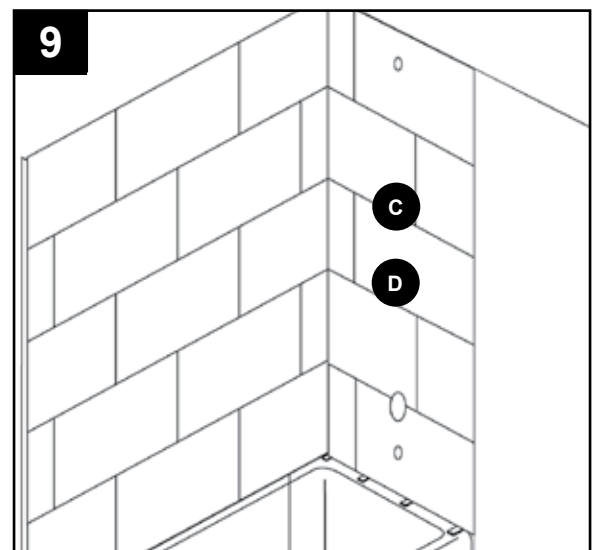

ASSEMBLY INSTRUCTIONS

10. If needed, place 1/16 in. thick shims at the base of the left side panel (C) and right side panel (D) installation site. Trial fit the left side panel (C) and right side panel (D) on the shims and use a sanding block if any fine adjustments are needed. Clean the back of the left side panel (C) and right side panel (D), the wall board and any other area that will be in contact with the silicone adhesive (L) with denatured alcohol and a clean rag (not included).

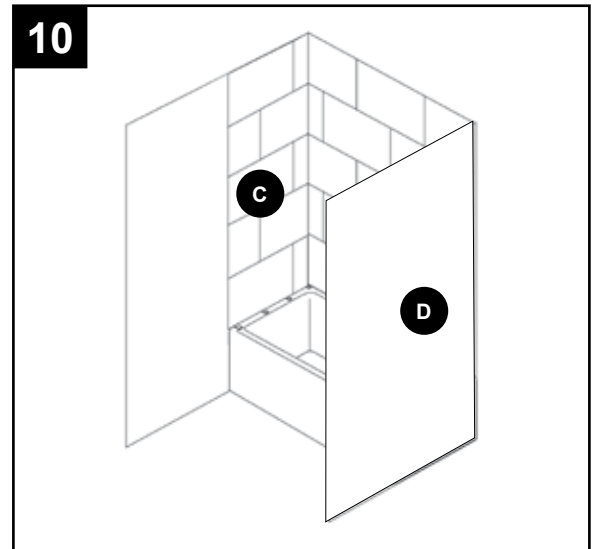

11. Cut twenty 4-in. strips of installation tape (N) and place them around the perimeter of left side panel (C) and right side panel (D), 2 in. from the edge and approximately 6-7 in. apart. Apply silicone adhesive (L) in 3/4 in. diameter dots every 6-7 in. apart over the back surface of the left side panel (C) and right side panel (D). Apply a thin bead of silicone adhesive (L) in the corner of the back wall assembly. Place left side panel (C) and right side panel (D) in place and press firmly. Clean up any excess silicone adhesive (L) with denatured alcohol while the silicone adhesive (L) is still wet.

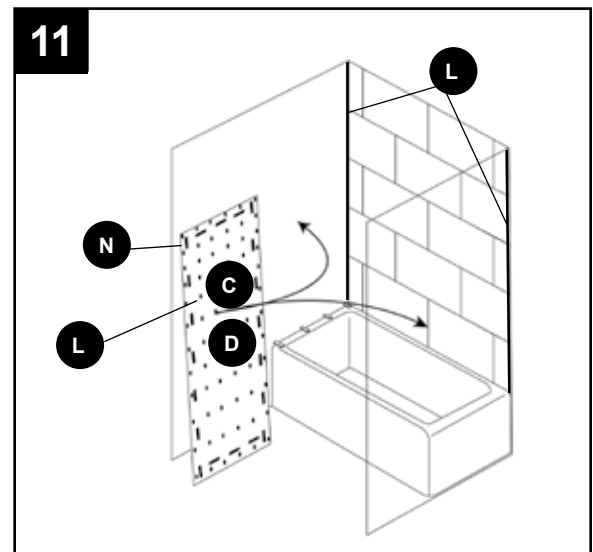

12. FRONT EDGE TRIM

Apply a continuous bead of silicone (L) along the front edge of left side panel (C) and right side panel (D), approximately 1/4 in. from the edge. Attach the front edge trims (E) to the front edges of left side panel (C) and right side panel (D) and press firmly to secure in place.

Note: Use masking tape (not included) or optional wood bracing to hold the front edge trim in place while the silicone adhesive (K) cures.

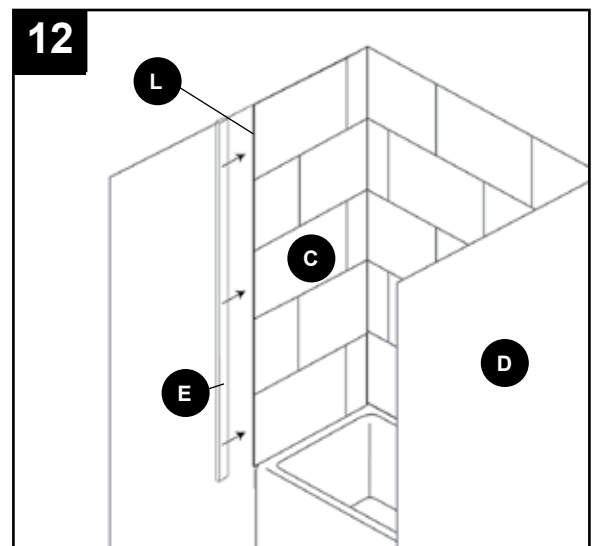

ASSEMBLY INSTRUCTIONS

13. BACK BULLNOSE MOLDING

Measure the width at the top of the back wall panel assembly and cut the back bullnose molding (G) to match the measurement. Trial fit the back bullnose molding (G) on upper face of the back wall panel (B) assembly and adjust as needed. Apply silicone adhesive (L) to the face of the top of the back wall panel assembly and place the back bullnose molding (G) on upper face of the back wall panel (B) firmly. Note: Use masking tape (not included) to hold the back bullnose molding (G) in place while the silicone adhesive (L) cures.

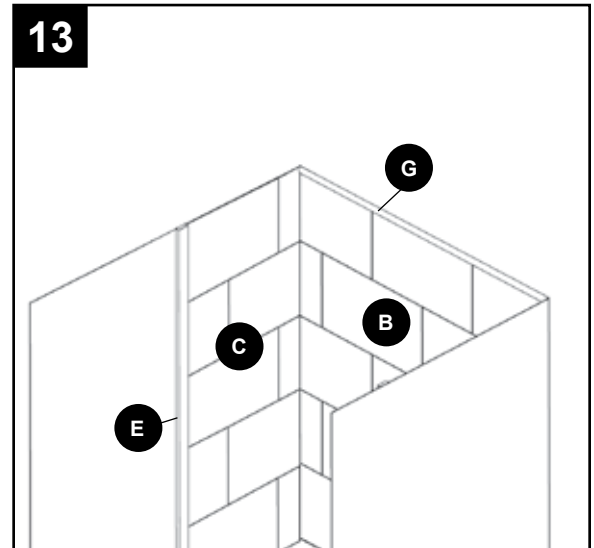

14. SIDE BULLNOSE MOLDING

Measure from the back wall panel assembly to the back of the front edge trim (E). Note: One end of side bullnose molding (F) is coped to fit over the back bullnose molding (G). Cut from the flat end of the side bullnose molding (F) to achieve the desired, correct measurement. Trial fit the side bullnose moldings (F) on upper face of the left side panel (C) and right side panel (D) and adjust as needed. Apply silicone adhesive (L) to the face of the top of the left side panel (C) and right side panel (D) and place the side bullnose molding (F) on the upper face firmly. Note: Use masking tape (not included) to hold the side bullnose molding (F) in place while the silicone (L) cures.

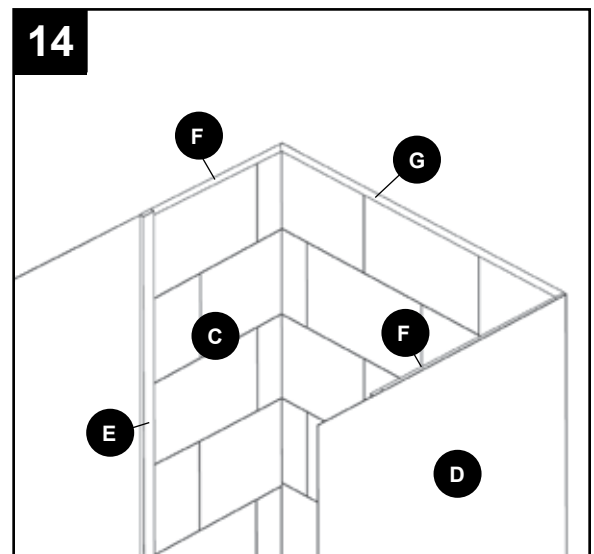

15. Install soap dish (J), left shampoo shelf (H), and right shampoo shelf (I) with mounting adhesive (M). Note: The recommended installation height for the soap dish (J) is 8 in. from the top of the tub deck and 42 in. for the left shampoo shelf (H) and right shampoo shelf (I). Trial fit left shampoo shelf (H) and right shampoo shelf (I) to ensure both sides are flat against the panels; adjust with a sanding block as needed. Clean the mounting area and the back of the left shampoo shelf (H), right shampoo shelf (I), and soap dish (J) with denatured alcohol. Follow the mounting adhesive (M) manufacturer's instructions for installation.

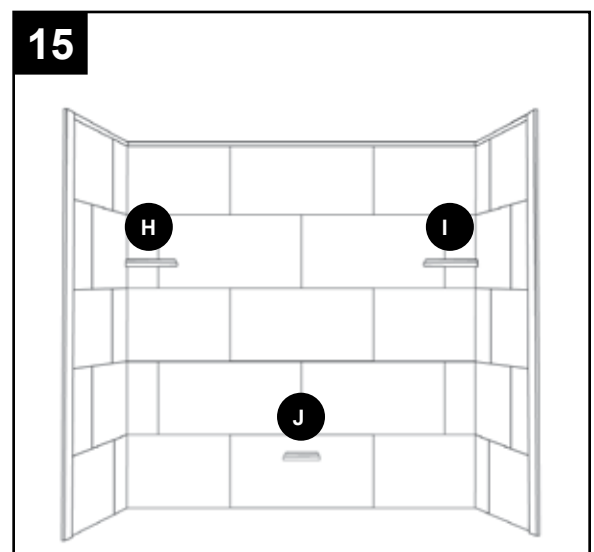

ASSEMBLY INSTRUCTIONS

16. Once installation is complete, seal all the joints with silicone adhesive (L). Note: Clean all joints with denatured alcohol before applying a uniform bead of silicone adhesive (L) to the joints.

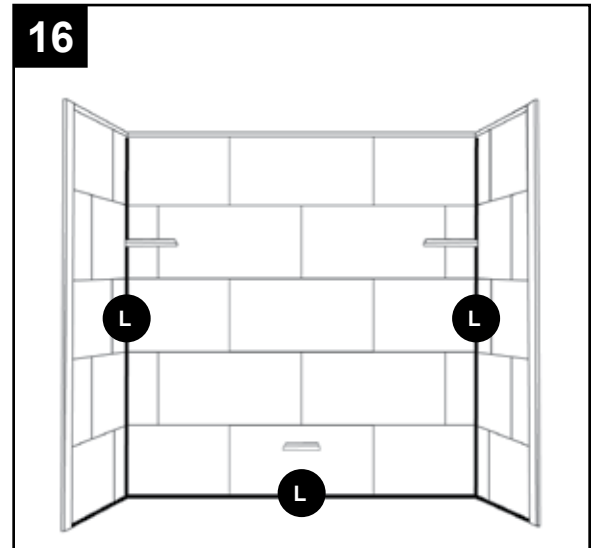

17. **OPTIONAL WOOD BRACING**

- To hold the installed panels more securely against the walls, place two wood braces (not included) against the back wall. Place two braces against each side wall.

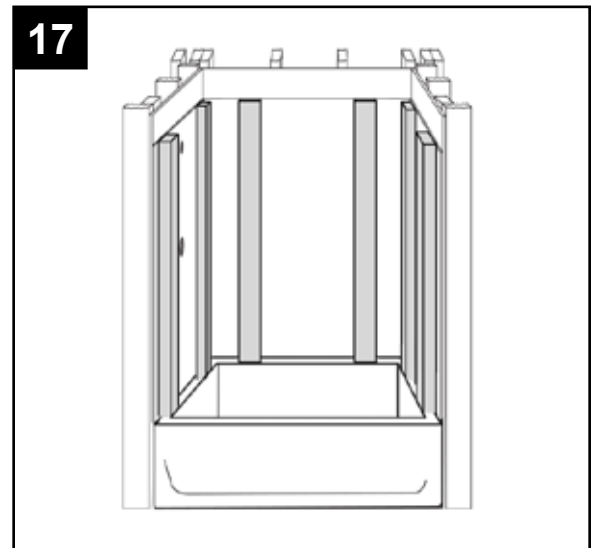

18. Wedge two horizontal wood braces (not included) against each left and right wall brace.

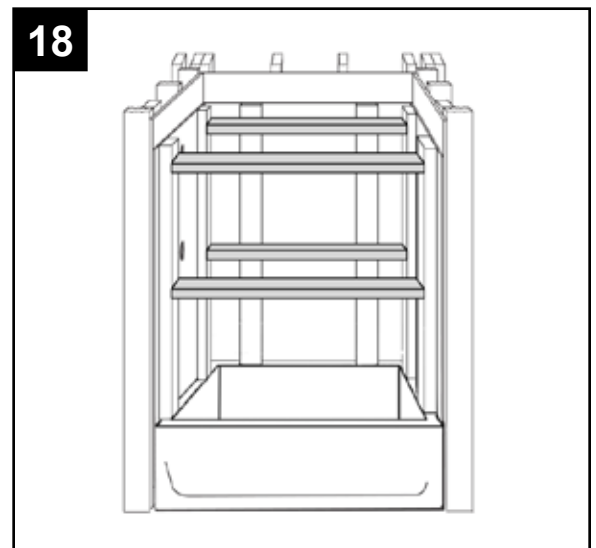

ASSEMBLY INSTRUCTIONS

19. Insert small blocks (not included) between the rear panel braces and the back panel braces. These will apply pressure to the back panel to hold it in place. Remove the braces after 24 hours.

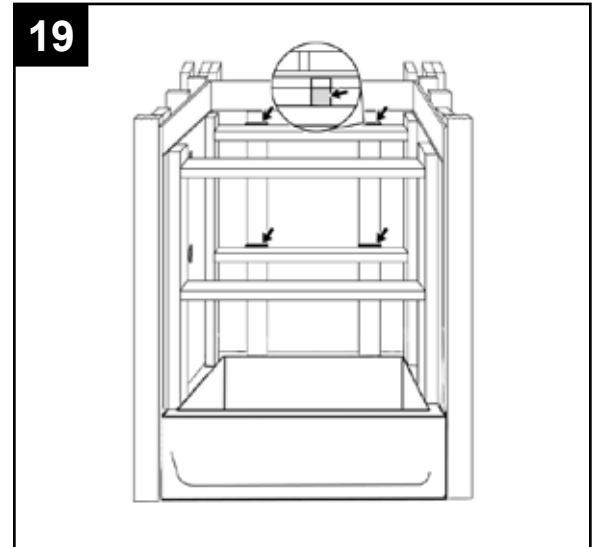

CARE AND MAINTENANCE

Wipe the surface with a damp cloth or sponge. For basic stains, clean with mild detergent or general purpose cleaner. For cleaning corners and seams, spray with mildew cleaner. With regular maintenance spraying there should be no need to scrub any silicone caulk joints.

TROUBLESHOOTING

PROBLEM	POSSIBLE CAUSE	CORRECTIVE ACTION
Panels not sticking to wall.	<ol style="list-style-type: none"> 1. Surfaces not properly prepared for silicone adhesive/sealant. 2. Wall surface not flat for proper adhesion. 	<ol style="list-style-type: none"> 1. Clean surface thoroughly and reapply adhesive. 2. Use wood bracing support to form panel to wall surface.
Panels not fitting properly.	<ol style="list-style-type: none"> 1. Existing wall surfaces out of plumb. 2. Improper trimming of wall panels. 3. Panel cut too small (less than 1/2 in.). 	<ol style="list-style-type: none"> 1. Scribe panels to fit. 2. Reorder miscut panel. 3. Order optional cove molding

WARRANTY

The manufacturer provides a LIMITED TEN (10) YEAR WARRANTY for its solid surface tub and shower surrounds to be free of manufacturing defects in materials and workmanship. If this product is found to be defective in materials or workmanship, after inspection by an authorized representative, we will repair, or at our option, exchange the product for a similar model. This warranty is valid for a period of ten (10) years, so long as it remains in use in its original place of installation.

This warranty covers only products installed in accordance with the installation instructions, used as recommended and not damaged due to misuse, abuse or improper installation. It does not apply to any seams or changes made to the product by professional tradesmen or fabricators.

The warranty applies only to the original purchaser and installation of these products in residential applications. It does not apply to commercial applications.

The manufacturer's option to repair or exchange the products under this warranty does NOT cover any labor or other costs of removal or installations, nor shall the manufacturer be responsible for any other incidental or consequential damages attributable to a product defect or to the repair or exchange of a defective product.

REPLACEMENT PARTS LIST

For replacement parts, call our customer service dept. at 1-877-632-6322,
8 a.m. - 8 p.m., EST, Monday - Friday, 9 a.m. - 5 p.m., EST, Saturday, 11 a.m. - 5 p.m., EST, Sunday.

PART	DESCRIPTION	PART #
A	Lower Backwall Panel	RTW-60LW-XX
B	Upper Backwall Panel	RTW-60UW-XX
C	Left Side Panel	RTW-32LW-XX
D	Right Side Panel	RTW-32RW-XX
E	Front Edge Trim	RTW-60FT-XX
F	Side Bullnose Molding	RTW-32CM-XX
G	Back Bullnose Molding	RTW-60BM-XX
H	Left Shampoo Shelf	RTW-8L-SS-XX
I	Right Shampoo Shelf	RTW-8R-SS-XX
J	Soap Dish	RTW-SC-SD-XX
K	Cove Molding	RTW-60-CM-XX
L	Silicone Adhesive	TSG-11-SA-CL
M	Mounting Adhesive	TSG-02-MA-XX
N	Installation Tape	TSH-02-IT

