

3-IN-1 TRIM MOLDING

Technical Information

3-in-1 Trim Molding

The **3-in-1 Trim Molding** functions as a **Reducer, T-Molding, and End Cap**. Comes with Track and Shim.

Surface Material: High Wear Resistant Aluminum Oxide Laminate

Core Material: PVC

Track - Used to install as Reducer, T-Molding, and End Cap

Material: Cold Roll Steel

Shim - Used to install as T-Molding and End Cap

Material: Standard HDF

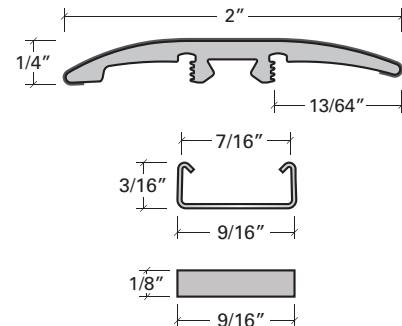

Applications



1 REDUCER

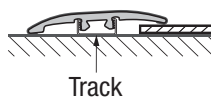

Track

2 T-MOLDING

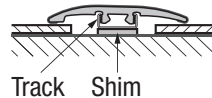

Track Shim

3 END CAP

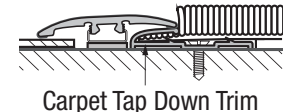

Carpet Tap Down Trim

Installation Instructions

1 3-in-1 Trim as a REDUCER

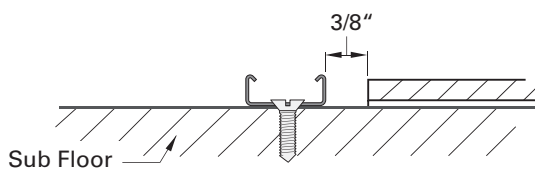

Sub Floor

*This end of the molding **MUST** be placed on the lower of the two surfaces.*



Step 1

Install the flooring plank. Then place the track 3/8" from the floor and screw it to the sub-floor using #4x3/4" screws.

IMPORTANT: Rock molding back & forth to make sure it is sitting inside the track **BEFORE** hammering in!

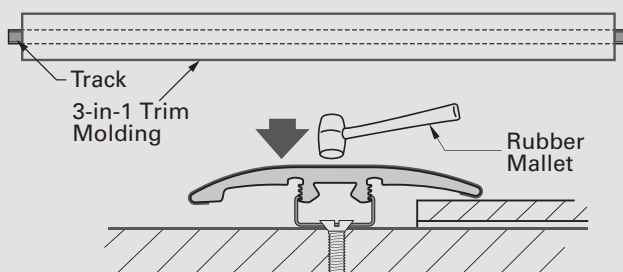

*If molding wiggles back and forth, it is **NOT** set in the track properly and will be damaged when hammered in!*

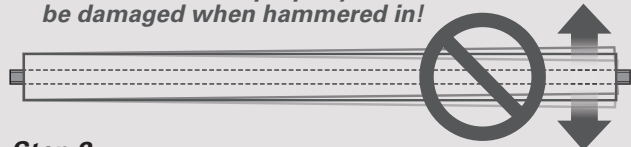

Step 2

Line the molding up with the track and fit one end into the molding. Using a rubber mallet, tap the molding until it engages with the track. **Use your hand to guide the molding into the track as you work your way down**, tapping it in, similar to how you would close a zip-loc bag.

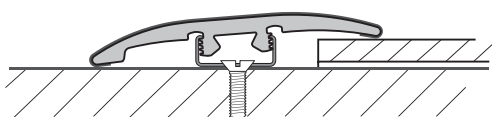

Step 3

Next, go up and down the molding several times, tapping it all the way into the track. You can use a little more force once you are sure it is properly engaged in the track.

3-IN-1 TRIM MOLDING

2 3-in-1 Trim as a T-MOLDING

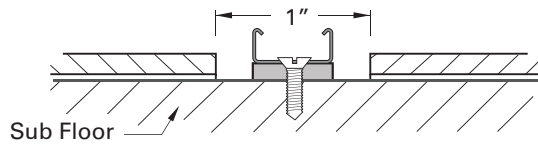

*This end of the molding **MUST** be placed on the lower of the two surfaces.*

Step 1

Install the flooring planks by leaving a 1" inch (25mm) gap for the installation of the molding. Center the track and shim between the two laminate floors and screw them to the sub floor by using #4x5/8" screws.



IMPORTANT: Rock molding back & forth to make sure it is sitting inside the track **BEFORE** hammering in!

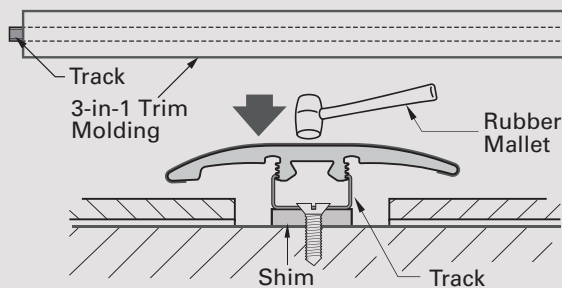

*If molding wiggles back and forth, it is **NOT** set in the track properly and will be damaged when hammered in!*

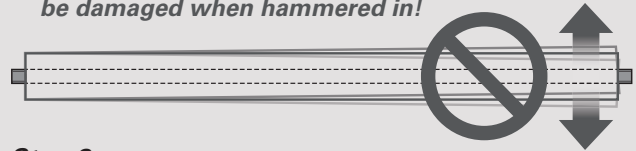

Step 2

Line the molding up with the track and fit one end into the molding. Using a rubber mallet, tap the molding until it engages with the track. **Use your hand to guide the molding into the track as you work your way down**, tapping it in, similar to how you would close a zip-loc bag.

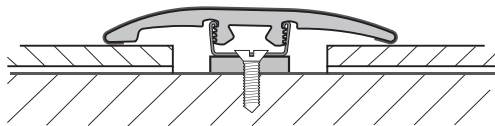

Step 3

Next, go up and down the molding several times, tapping it all the way into the track. You can use a little more force once you are sure it is properly engaged in the track.

3 3-in-1 Trim as an END CAP

NOTE: Carpet Tap Down trim must be even with the top of the track.

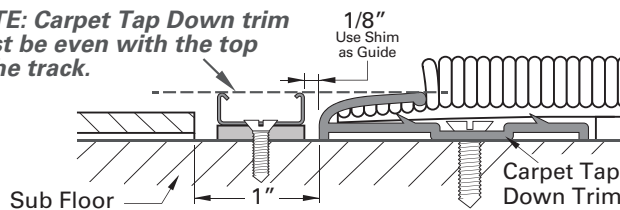

*This end of the molding **MUST** be placed on the lower of the two surfaces.*

Step 1

Install the flooring plank and carpet (using a carpet tap down trim) by leaving a 1" inch (25mm) gap for the installation of the molding. Position the track 3/4" from where the top of the Tap Down trim meets the carpet and screw them to the sub floor by using #4x5/8" screws. The carpet tap down trim must be even with the top of the track.



IMPORTANT: Rock molding back & forth to make sure it is sitting inside the track **BEFORE** hammering in!

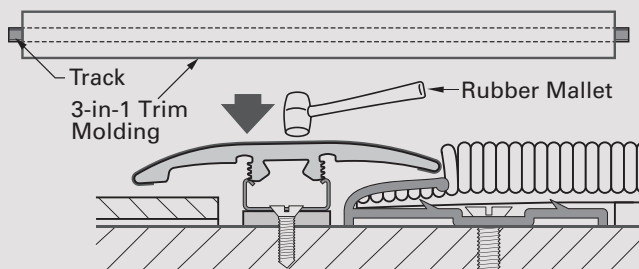

*If molding wiggles back and forth, it is **NOT** set in the track properly and will be damaged when hammered in!*

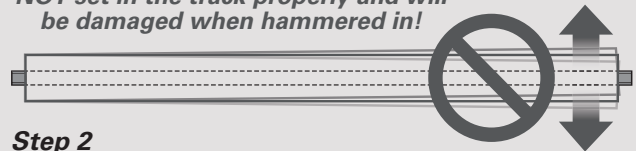

Step 2

Line the molding up with the track and fit one end into the molding. Using a rubber mallet, tap the molding until it engages with the track. **Use your hand to guide the molding into the track as you work your way down**, tapping it in, similar to how you would close a zip-loc bag.

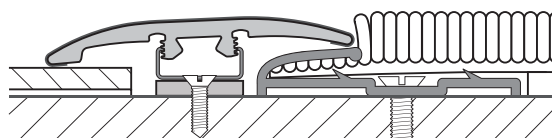

Step 3

Next, go up and down the molding several times, tapping it all the way into the track. You can use a little more force once you are sure it is properly engaged in the track.