

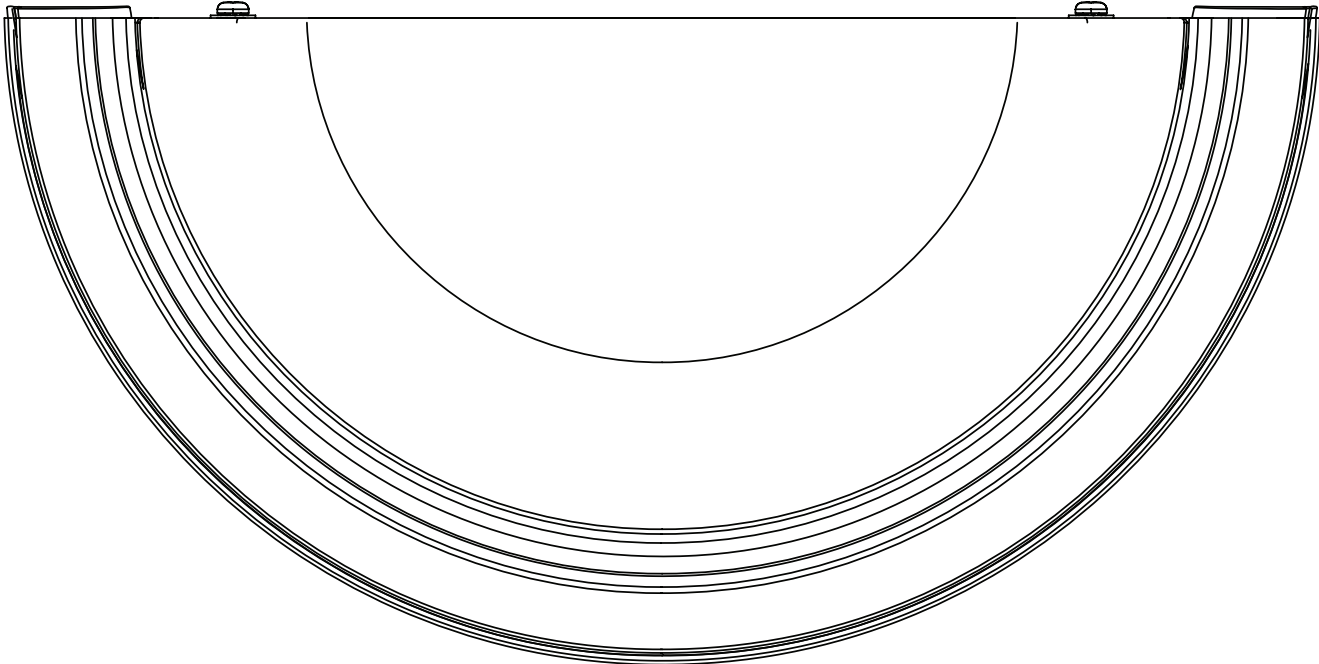

ITEM #0430587
WALL SCONCE
MODEL #40628

Portfolio® is a registered trademark of LF, LLC. All Rights Reserved.



ATTACH YOUR RECEIPT HERE

Serial Number _____ Purchase Date _____



Questions, problems, missing parts? Before returning to your retailer, call our customer service department at 1-800-643-0067, 8 a.m. - 6 p.m., EST, Monday - Thursday, 8 a.m. - 5 p.m., EST, Friday.

PACKAGE CONTENTS

A

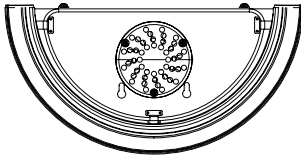

B

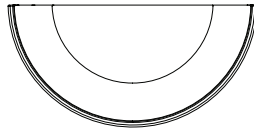

C

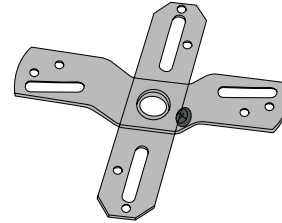

PART	DESCRIPTION	QUANTITY
A	Fixture Body	1
B	Glass Shade	1
C	Mounting Bracket	1

HARDWARE CONTENTS (shown actual size)

AA



Mounting
Screw
Qty. 2

BB

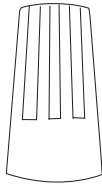

Wire Connector
Qty. 3

CC



Bracket Screw
Qty. 2



SAFETY INFORMATION

Please read and understand this entire manual before attempting to assemble, operate, or install the product.



WARNING:

- Some metal parts in the fixture may have sharp edges. To prevent cuts and scrapes, wear gloves when handling parts.
- Account for small parts and destroy packing material, as these may be hazardous to children.
- Use flashlight or alternate light source to light work area during installation.
- Assistance may be required to support fixture during installation.

CAUTION:

- Read all instructions and safety information before installing the light. Review the accompanying assembly diagrams.
- Be sure the outlet box is properly grounded or that a ground (green or bare) wire is present.
- Carefully check all screws, bolts, and nuts to ensure they are secured.

PREPARATION

Before beginning installation of product, make sure all parts are present. Compare parts with package contents list and diagram on previous page. If any part is missing or damaged, do not attempt to assemble, install or operate the product.

Estimated Assembly Time: 20-30 minutes.

Tools Required for Assembly (not included): Flathead Screwdriver, Phillips Screwdriver, Pliers, Wire cutters, Electrical tape, Safety goggles, and Step ladder.

Helpful Tools (not included): Wire Strippers

1. Shut off power at the circuit breaker or fuse panel before removing the old fixture.

⚠ DANGER: Failure to disconnect the power supply prior to installation may result in serious injury or death.

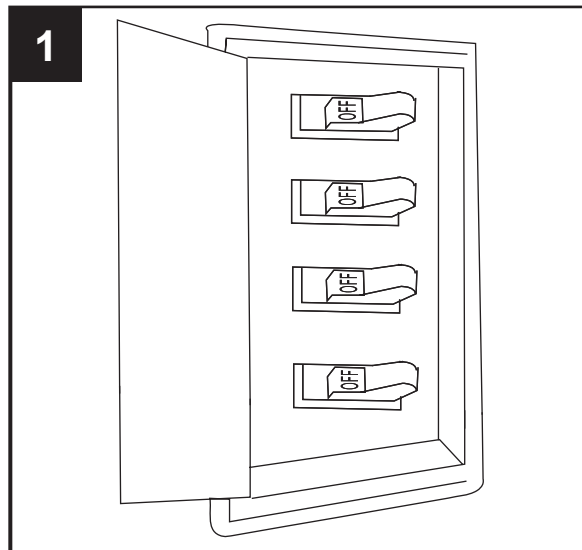

2. Remove the old fixture. To better assist you later in the wiring process, consider making a sketch of how the fixture is wired before you remove it.

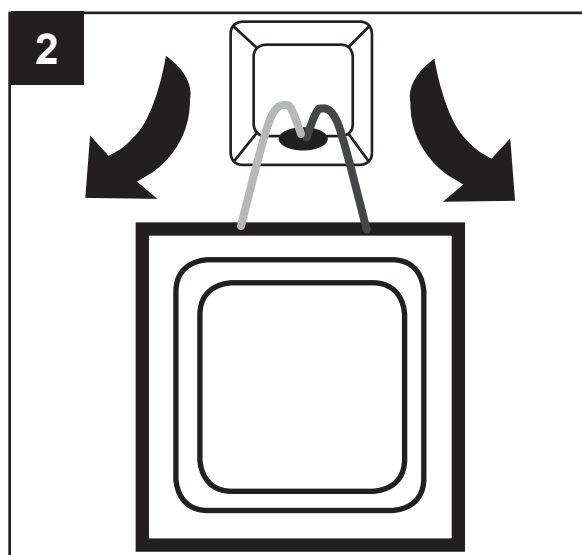

ASSEMBLY INSTRUCTIONS

1. Attach the mounting bracket (C) to the electrical box (not included) with the two bracket screws (CC).

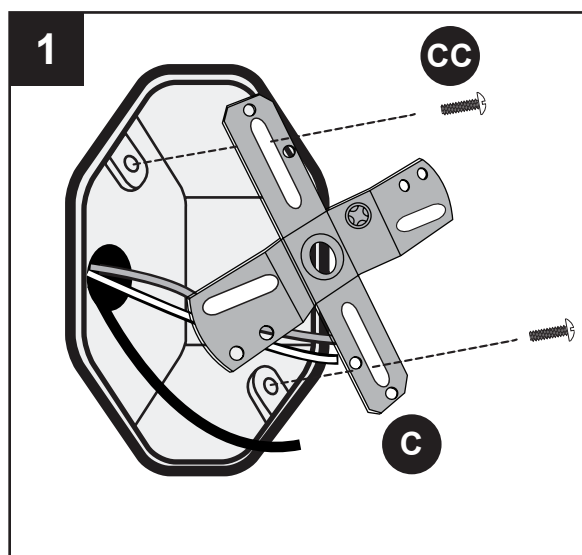

Hardware Used

CC Bracket Screw  x 2

⚠ DANGER: For safety and proper operation, the fixture must be properly grounded. If you are unfamiliar with the methods of properly grounding the fixture, consult a qualified electrician.

2. A green or bare copper ground wire is pre-attached to the fixture body (A). If the electrical box has a green or bare copper grounding wire inside, the bare end of the fixture grounding wire must be secured to the green grounding wire inside the electrical box using one of the wire connectors (BB).

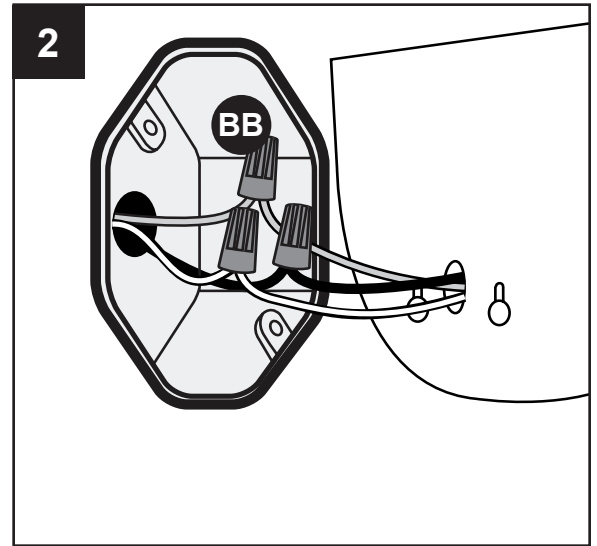

Hardware Used

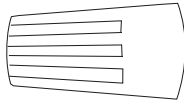
- BB** Wire Connector  x 1

3. Connect the supply leads from the electrical box to the fixture wire leads using the wire connectors (BB). The black lead from the fixture goes to the black supply lead and the white lead from the fixture goes to the white supply lead.

Hardware Used

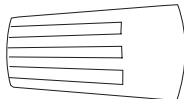
- BB** Wire Connector  x 3

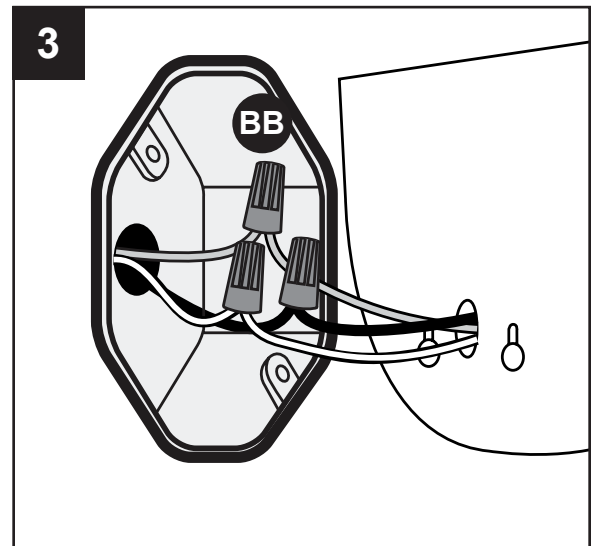

4. Tape the wire connectors (BB) to the wire using electrical tape (not included). Carefully push the excess wires back inside the electrical box.

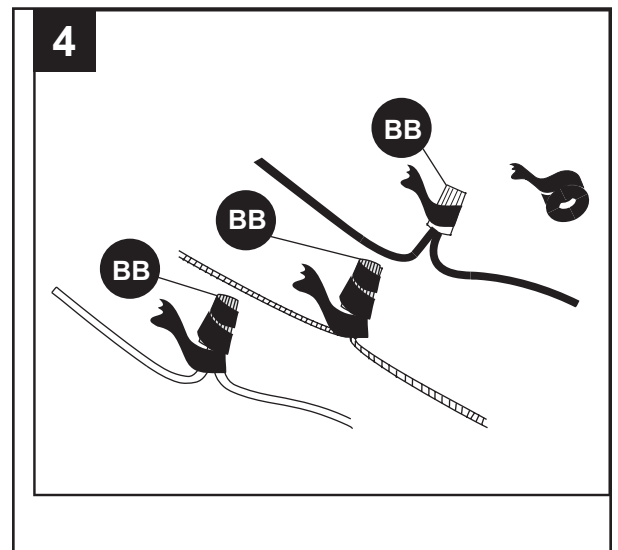

5. Locate the elongated keyhole slots on the fixture body (A) on each side of the pre-installed LED light. The slots are arranged to align with most electrical boxes' mounting holes.

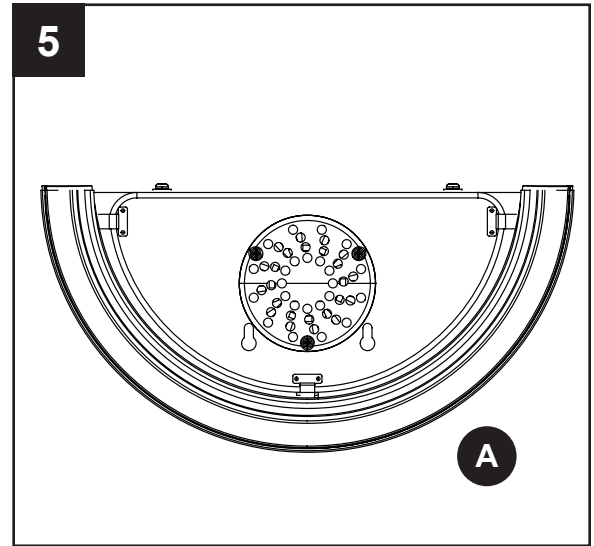

6. Position the fixture body (A) over the electrical box and line up the slots in the fixture body (A) with the slots in the mounting bracket. Hold in place and secure with mounting screws (AA).

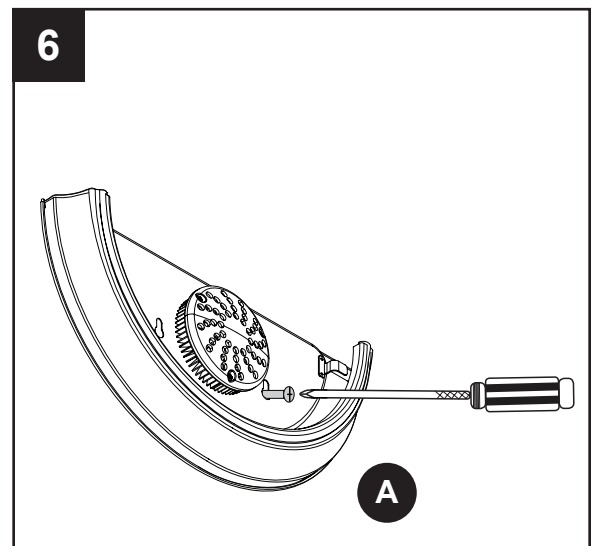

Hardware Used

- AA** Mounting screw  x 2

7. Lower the glass shade (B) into the fixture body (A), being careful not to break the bulb. **Note:** The lip of glass shade (B) should sit behind the lip of the fixture body (A). Restore power to the fixture to ensure it's working correctly.

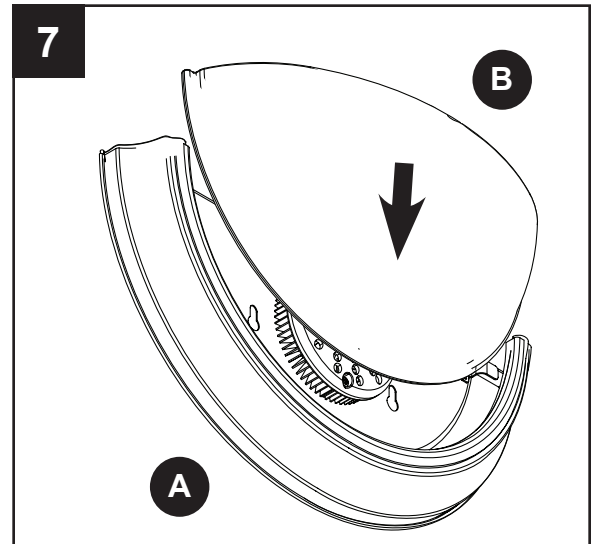

CARE AND MAINTENANCE

Important: Shut off the main power supply before you begin any maintenance tasks. Periodically clean the fixture using a mild, non-abrasive glass cleaner and soft cloth. Do NOT use solvents or cleaners containing abrasive agents and do not spray liquid cleaner directly onto the bulb or wiring.

TROUBLESHOOTING

PROBLEM	POSSIBLE CAUSE	CORRECTIVE ACTION
The fixture doesn't light.	<ol style="list-style-type: none"> 1. The power is off or the fuse is blown. 2. There is a faulty wire connection. 3. The switch is bad. 	<ol style="list-style-type: none"> 1. Turn the power on or check the fuse. 2. Turn the power off and check all wire connections. 3. Test or replace the switch.
The fuse blows or circuit breaker trips when light is turned on.	There are wires crossed or the power wire is grounded out.	Turn the power off and check all wiring connections.

ONE-YEAR LIMITED WARRANTY

The manufacturer warrants all of its lighting fixtures against defects in materials and workmanship for one (1) year from the date of purchase. If within this period the product is found to be defective, take a copy of the bill of sale as a proof of purchase and the product in its original carton to the place of purchase. The manufacturer will, at its option, repair, replace or refund the purchase price to the consumer. All costs of installation and removal of the fixture is the responsibility of the consumer. This warranty does not cover fixtures becoming defective due to misuse, accidental damage or improper handling and/or installation and specifically excludes liability for direct, incidental or consequential damages. As some states do not allow exclusions of limitations on an implied warranty, the above exclusion and limitation may not apply. This warranty gives you specific rights and you may also have other rights which may vary from state to state.

REPLACEMENT PARTS LIST

For replacement parts, call our customer service department at 1-800-643-0067, 8 a.m. - 6 p.m., EST, Monday - Thursday, 8 a.m. - 5 p.m., EST, Friday.

PART	DESCRIPTION	PART#
B	Glass Shade	430587-B
C	Mounting Bracket	430587-C
HW	Hardware Bag	430587-HDWE

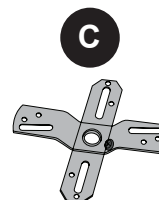
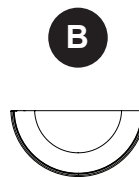

Printed in China

Portfolio® is a registered trademark of LF, LLC. All Rights Reserved.