

## Performance and Performance Diamond 2.0

---



### **Warning: Excessive weight hazard!**

Use two or more people to move, assemble, or install cabinets and locker to avoid back injury. Do not leave children unattended near cabinets. High risk of tipping if cabinets are installed incorrectly: securely attach cabinets to the wall to avoid serious injury. For assistance, call 1.877.306.8930; for U.K 0800.031.4069; e-mail at [info@newageproducts.com](mailto:info@newageproducts.com).

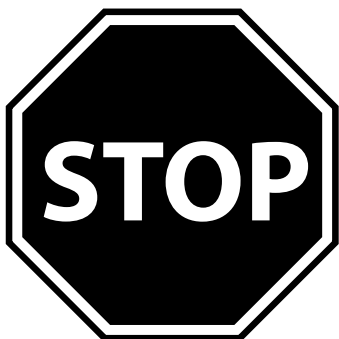

**ATTENTION:** Is your cabinet damaged? Need help or spare parts? For fastest service, contact NewAge Products at 1-877-306-8930; or [support@newageproducts.com](mailto:support@newageproducts.com). Do not return to the retailer.

# INDEX

## **Product Overview:**

[Unpacking - 3](#)

[Tools Needed - 3](#)

[Included Quantities - 4](#)

[Included Parts - 4](#)

[Weight Capacity - 5](#)

[Worktop Options - 5](#)

## **[Installation Options - 6](#)**

## **Installation Overview:**

[Floor Installation - 7](#)

[Wall Mount Installation - 8](#)

[Slatwall Installation - 9](#)

[Sets with Casters - 10](#)

[Corner Set Installation - 11](#)

## **Hanging Wall Cabinets:**

[On Studded Wall - 12](#)

[On Slatwall - 13](#)

## **Securing Wall Cabinets:**

[To Wall - 14](#)

[To Other Cabinets - 15](#)

[Fastening Cabinets on Casters - 16](#)

## **Installing Worktop:**

[Standard installation on cabinets - 17](#)

[Using Support Brackets - 18](#)

[Corner Worktop - 19](#)

## **General Assembly:**

[Feet & Levelling cabinets - 20](#)

[Casters - 21](#)

[Drawers - 22](#)

[Handles - 23](#)

[Stacking - 24](#)

[Closet Rod - 25](#)

[Shelves - 26](#)

[Utility hole - 27](#)

[Magnetic Racing Stripe - 28](#)

[Warranty - 29](#)

# Unpacking

- Begin by placing the package on a covered flat surface.
- Remove all cardboard, foam packaging material and clear plastic bags.
- Dispose / recycle all packaging materials.
- Verify all the contents in the box and gather the required tools. See "Tools Needed", and "Included Quantities" list.

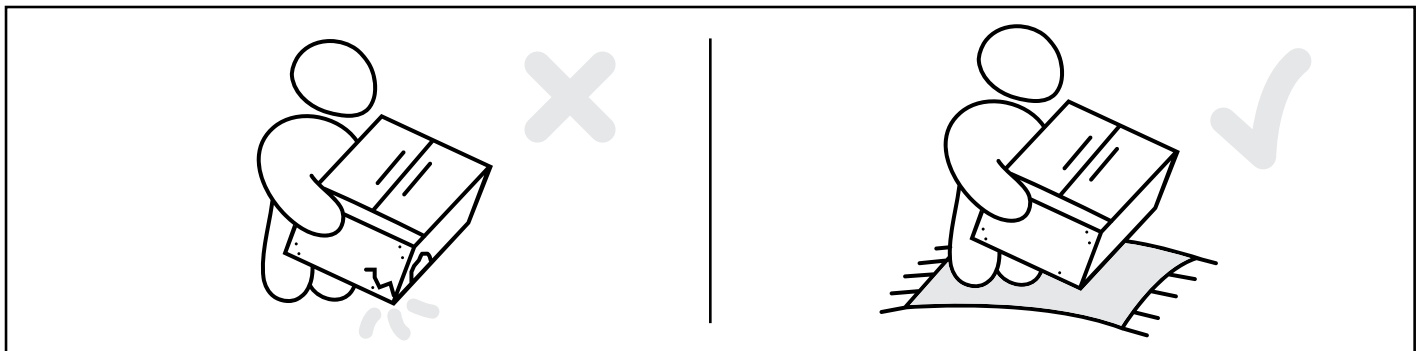
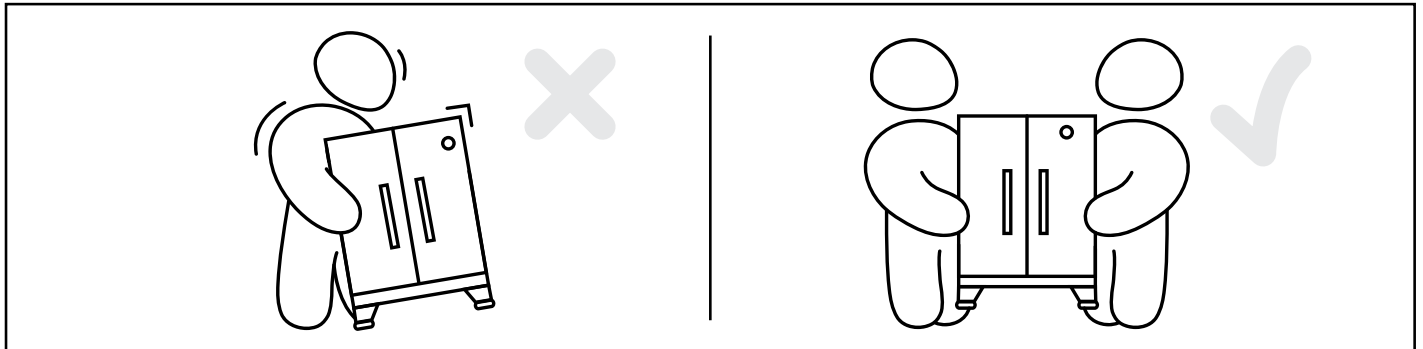

## Tools Needed

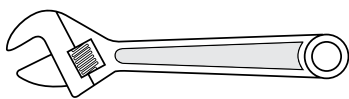

**1 x** Adjustable wrench

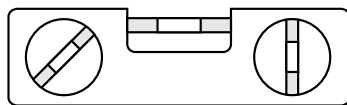

**1 x** 12" Magnetic Level



**1 x** Stud Finder

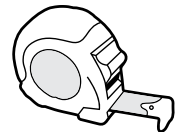

**1 x** Tape Measure



**1 x** 7/16" Socket driver wrench

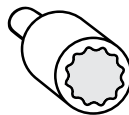

**1 x** 7/16" socket

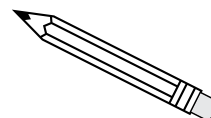

**1 x** Pencil

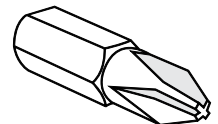

**1 x** #2 Phillips Bit

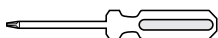

**1 x** #2 Phillips head screwdriver



**1 x**  
6 mm or 3/16"  
drill bit



**1 x** Cordless Power Drill

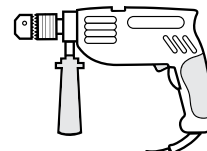

**1 x** Hammer Drill



**1 x** Masonry Bit  
[optional for masonry]

# Included Quantities

	Base Cabinet	30in Locker	Wall	Corner Wall	Mobile Tool Drawer	42in Locker
Hardware Pack	1	1	1	1	1	1
Cabinet Leg	4	4	0	0	0	4
Leveling Foot	4	4	0	0	0	4
Adjustable Steel Shelves	1	3	0	0	0	3
Handles	2	2	0	0	4	2
Closet Rod	0	1	0	0	0	1
Locker Support Bracket	0	1	0	2	0	1
Joining Bracket	1	0	0	2	0	0
Worktop Wall Support	0	0	0	2	0	0
EVA Foam Drawers Liners	0	0	0	0	4	0
Utility Hole Grommet	1	1	0	0	0	1
NewAge Logo	1	1	1	1	1	1
4in Casters	0	0	0	0	4	0

# Individual Parts

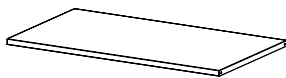

Adjustable Steel Shelves

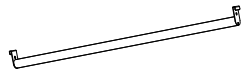

Closet Rod

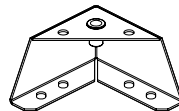

Cabinet Leg



Handle

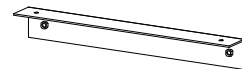

Locker Support Bracket

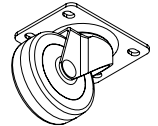

4in Casters

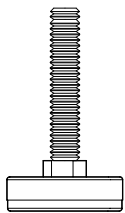

Leveling Foot (M10 x 65mm)

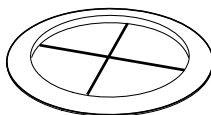

Utility Hole Grommet

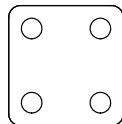

Joining Bracket

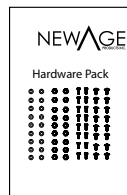

Hardware Pack



NewAge Logo

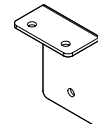

Worktop Wall Support



EVA Foam Drawer Liners

# Weight Capacity



250 lbs per foot.  
1000 lbs. per Set of 4



3in Casters  
600 lbs. / set of 4  
150 lbs. / caster

4in Casters  
1000 lbs. / set of 4  
250 lbs. / caster

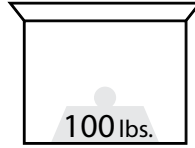

Wall Cabinets  
Max 100 lbs.

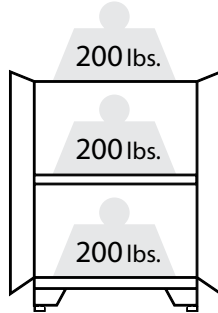

Base Cabinet  
Max 600 lbs.

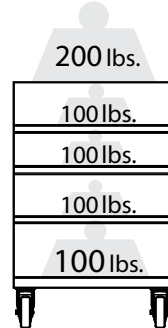

Tool Cabinet  
Max 600 lbs.

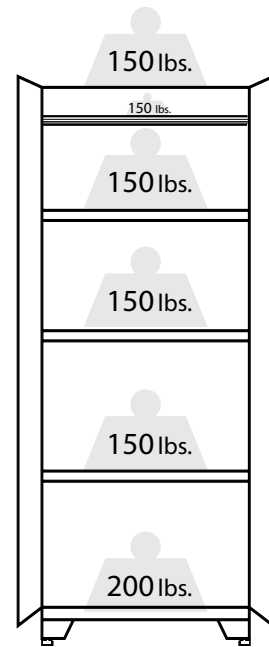

Locker  
Max 800lbs.

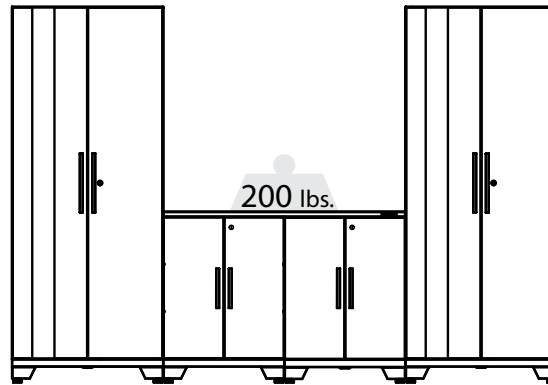

Worktop on Cabinets  
Max 200 lbs. / Cabinet

# Worktop Options

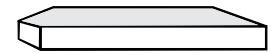

21" Corner Worktop

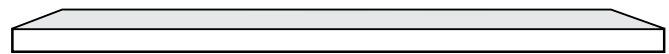

48" Worktop. Fits over 2 Cabinets

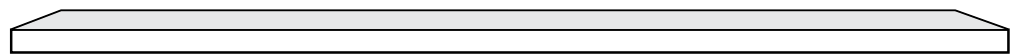

72" Worktop. Fits over 3 Cabinets

# Installation options for Cabinets

**i** **Important information:** Please read before beginning installation.

- Layouts shown are only examples. All cabinets are mobile and can be configured in a variety of different layouts.
- Plan layout and measure space before installing.
- Locate wall studs prior to installation.
- Consider the location of electrical outlets when planning layout.
- Measure height of cabinets for clearance.
- Base cabinets can be mounted flush front or flush back with Locker cabinets.

**Option 2.** - see [page 8](#).

Wall mount cabinets off floor.

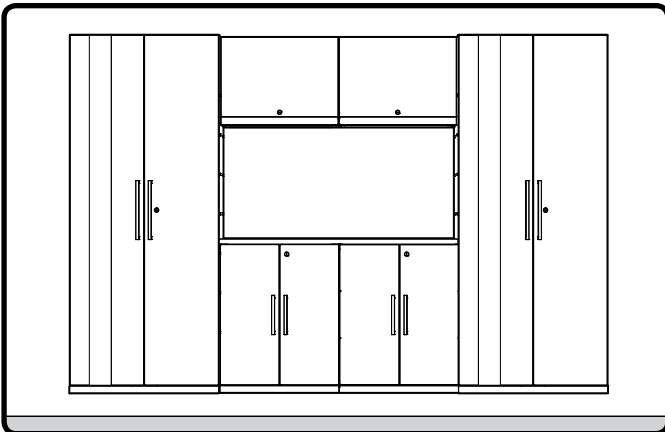

**Option 4.** - see [page 10](#)

Sets with casters and adjustable leveling legs.

**Note:** Casters cannot be installed on Locker cabinets. Casters not included in all sets.

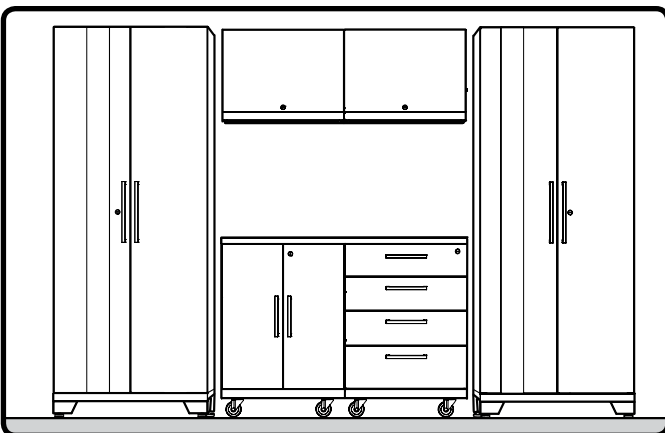

**Option 1.** - see [page 7](#).

Floor mount with adjustable levelling legs.

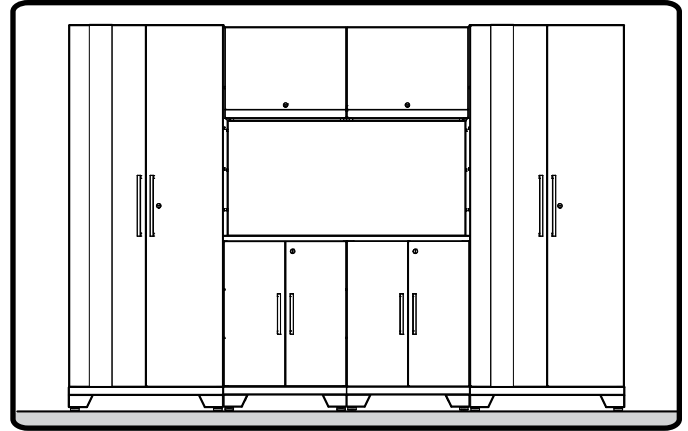

**Option 3.** - see [page 9](#).

Wall mount on slatwall using slatwall brackets (sold separately).

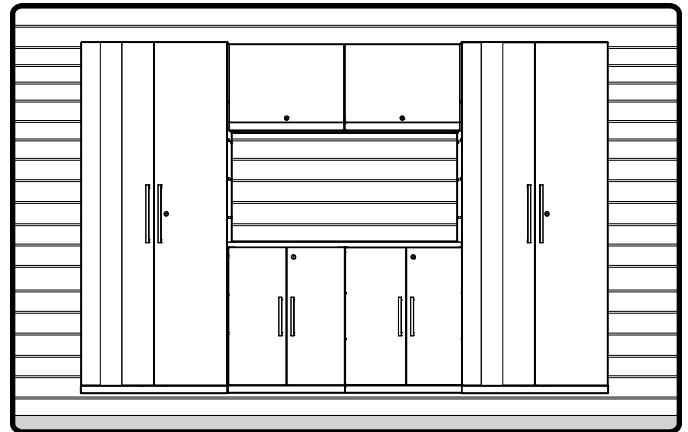

**Option 5.** - see [page 11](#)

Corner set installation. **Note:** Corner cabinets can be installed using all installation options.

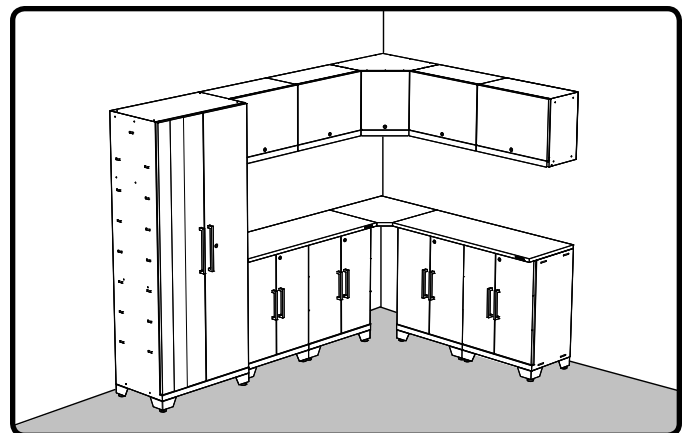

## Option 1

# Floor Installation Overview

**i** Plan layout before installing cabinets.

- It is recommended to begin installation with Locker cabinet.
- Cabinets must be fully secured to wall using (4) wall screws per cabinet.
- Casters can not be installed on locker cabinets.

**1** Attach feet to cabinets. See feet installation on [page 20](#).

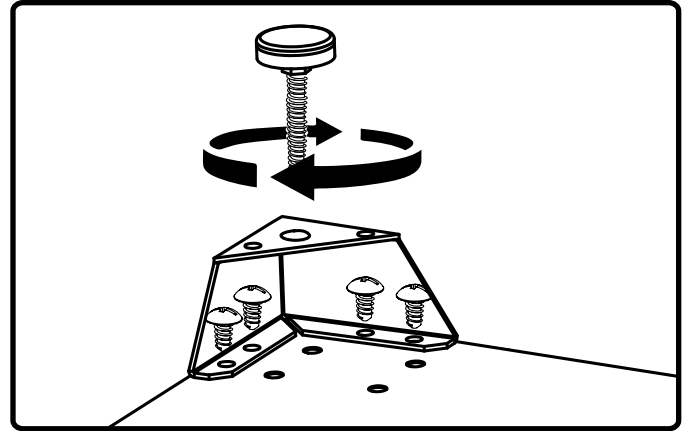

**2** Begin by securing Locker cabinet to wall in determined position. See [Page 14](#) for full instructions.

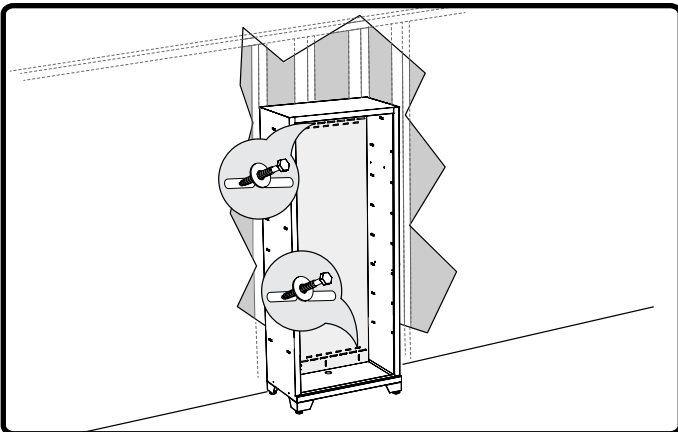

**3** Position and secure remaining cabinets to wall. Install cabinets one at a time. See [Page 14](#) for full instructions.

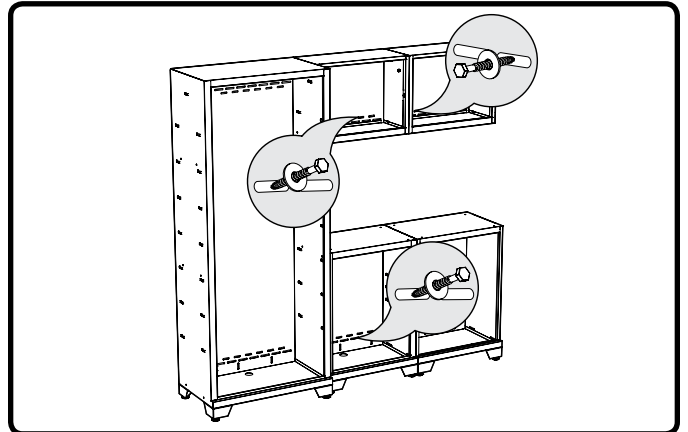

**4** Attach cabinets together. See [page 15](#) for detailed fastening instructions.

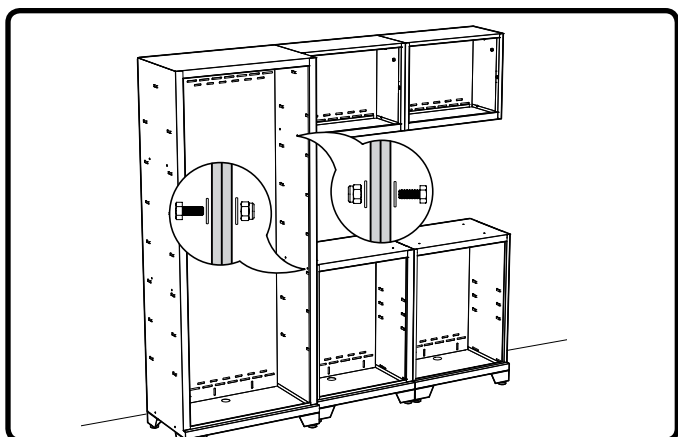

**5** Attach worktop. See [page 17](#) for full instructions.

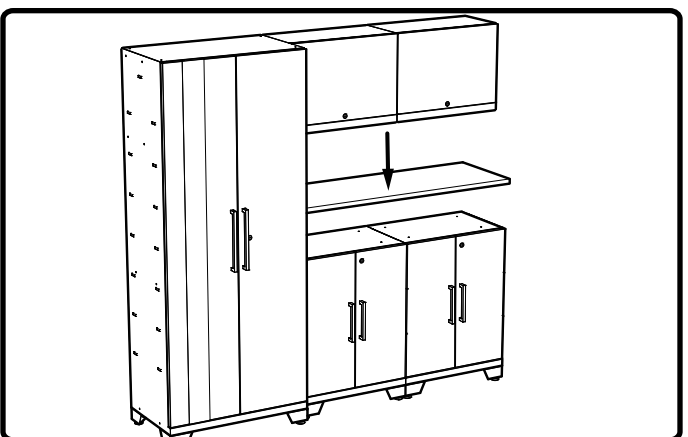

## Option 2

# Wall Mount Installation Overview

**i** Plan layout before installing cabinets.

- Determine height cabinets will be installed off the ground.
- It is recommended to begin installation with Locker cabinet.
- Install cabinets one at a time.
- Cabinets must be fully secured to wall using (4) wall screws per cabinet.

**1** Begin by attaching Locker cabinet to wall. See [page 12](#) for full instructions on hanging cabinets.

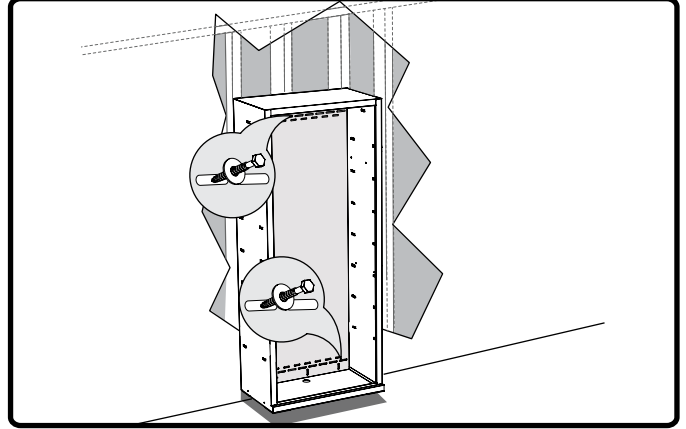

**2** Position and secure remaining base cabinets, and wall cabinets to wall. See [page 12](#).

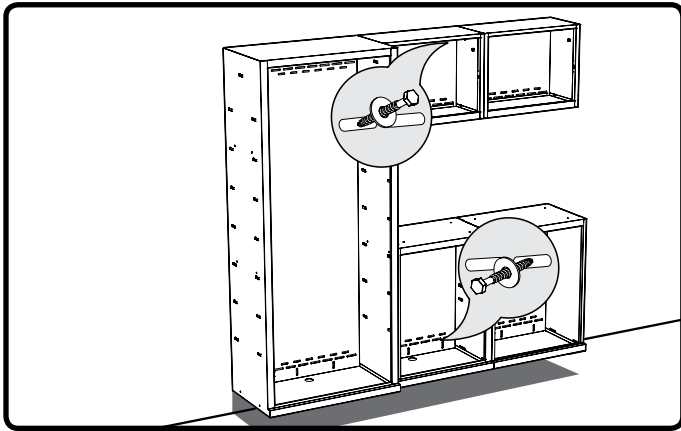

**3** Attach cabinets together. See [page 15](#).

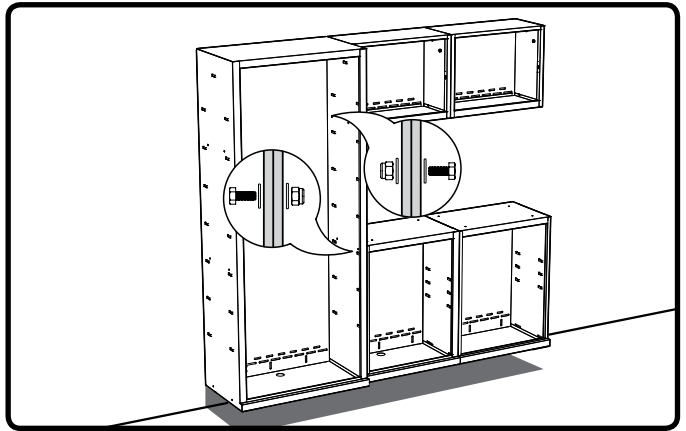

**4** Attach worktop. See [page 17](#) for full instructions.

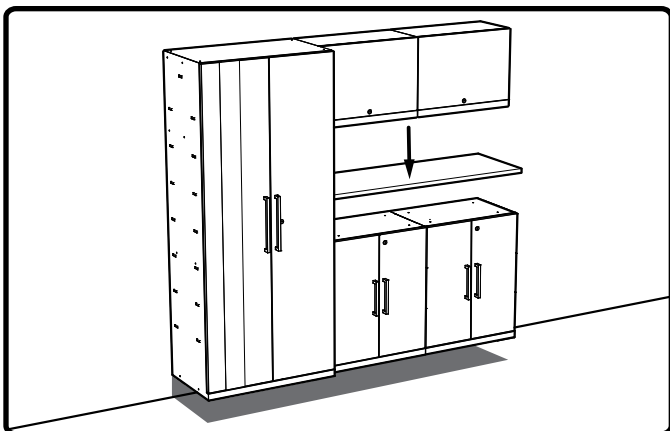



## Option 3

# Slatwall Installation Overview

**i** Plan layout before installing cabinets.

- Determine height cabinets will be installed off the ground.
- Slatwall bracket sold separately
- Slatwall brackets for use with standard 3" slatwall.
- Check slatwall manufacturer for rated load capacity.
- Do not overload.

**1** Begin by attaching locker cabinet to slatwall using slatwall bracket. See [page 13](#) for slatwall hanging instructions.

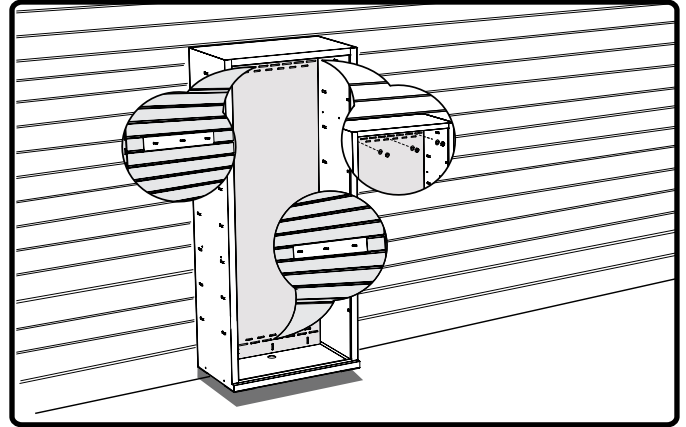

**2** Position and secure remaining base cabinets, and wall cabinets.

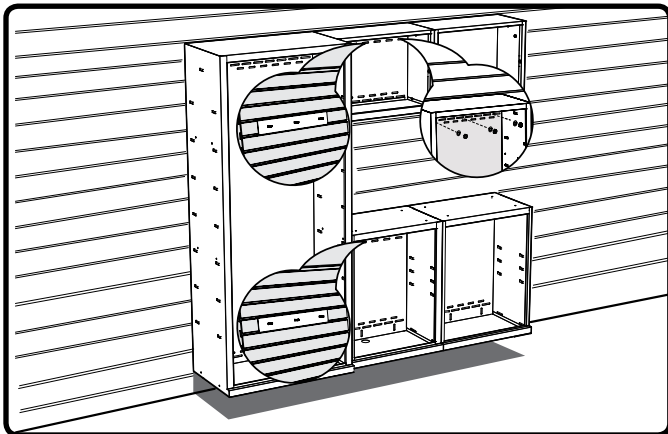

**3** Attach cabinets together.

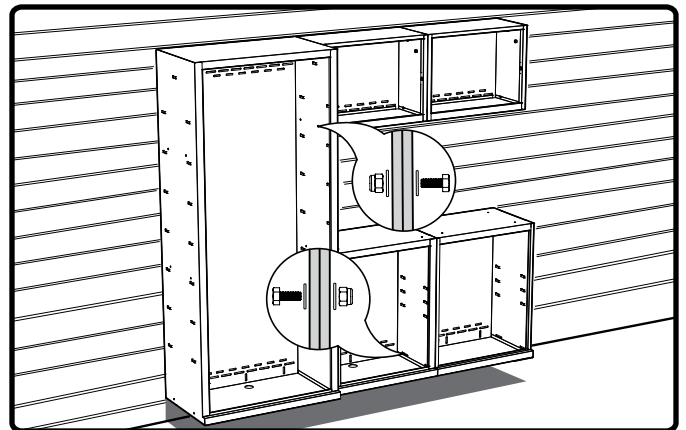

**4** Attach worktop. See [page 17](#) for full instructions.

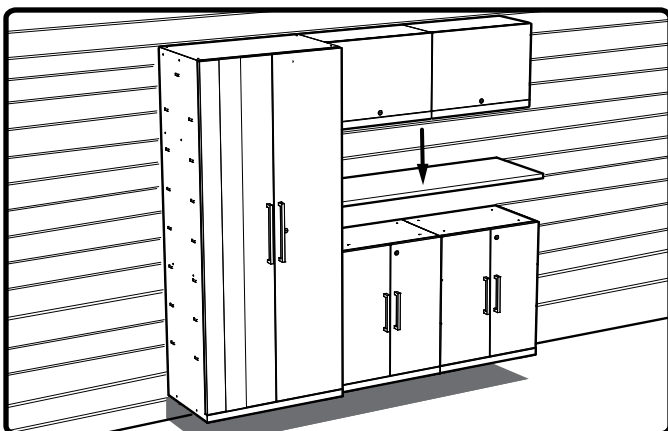

**i** Slatwall brackets sold separately. See below for quantities needed.

- Locker and Base Cabinets - per cabinet (2) x 24" Slatwall Brackets. Part # 50979
- Wall Cabinets - per cabinet (1) x 24" Slatwall Brackets. Part # 50979
- Corner Wall Cabinets - per cabinet (2) x 12" Slatwall Cabinets. Part # 50980

## Option 4

# Caster Set Installation Overview

**i** Plan layout before installing cabinets.

- It is recommended to begin installation with Locker cabinet.
- Install cabinets one at a time.
- Locker and wall cabinets must be fully secured to wall using (4) wall screws per cabinet.
- Casters not included in all sets.

**2** Begin by securing Locker cabinet to wall in determined position. See [Page 14](#) for full instructions.

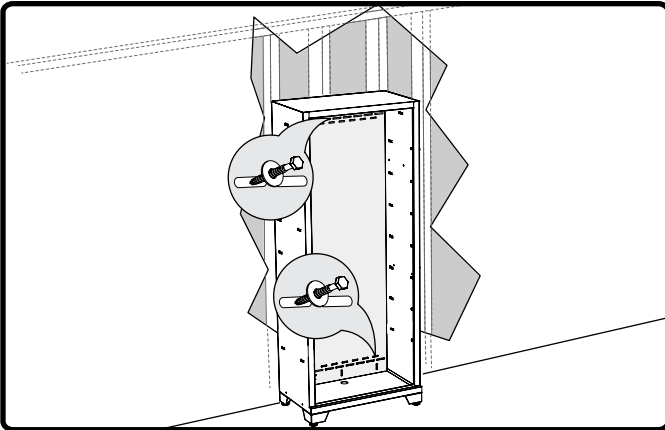

**1** Attach feet to locker cabinets. Attach casters to base cabinets. See full installation on [pages 20 & 21](#).

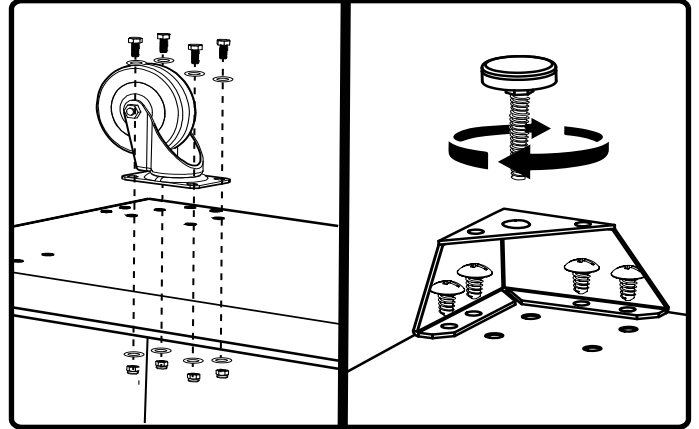

Secure wall cabinets to wall and fasten together.

**3** A gap of 2" is recommended between wall and locker to allow clearance for cabinets on casters. See [page 14 & 15](#) for full instructions.

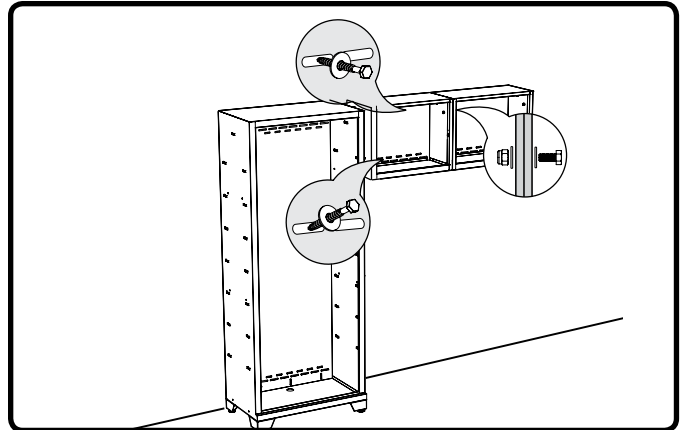

**4** Attach base cabinets together using joining plate and attach worktop. See [page 16-17](#).

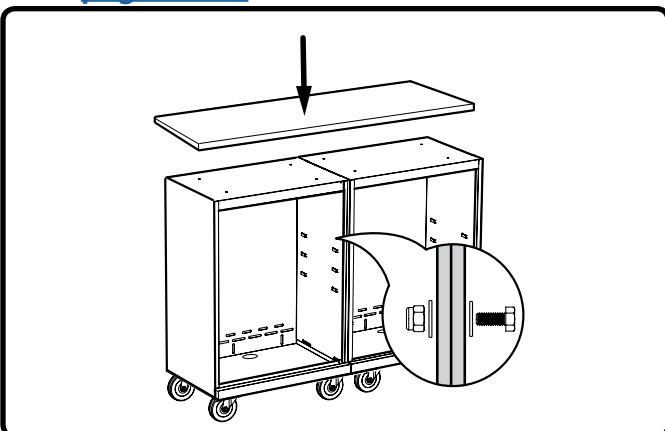

**5** Position cabinets.

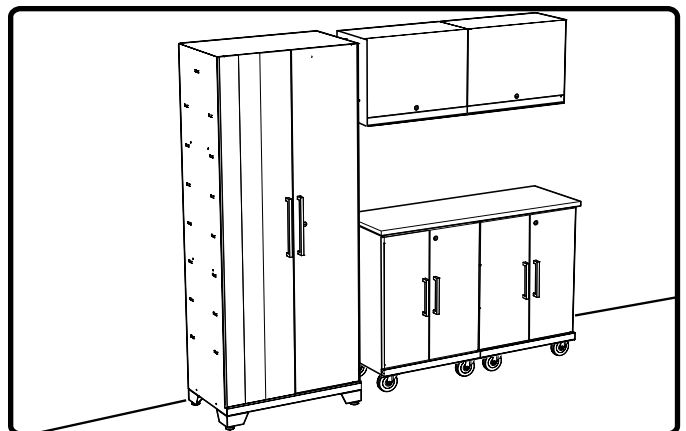

## Option 5

# Corner Cabinet Installation Overview

- 1** Attach feet to cabinets. See full feet installation on [page 20](#).

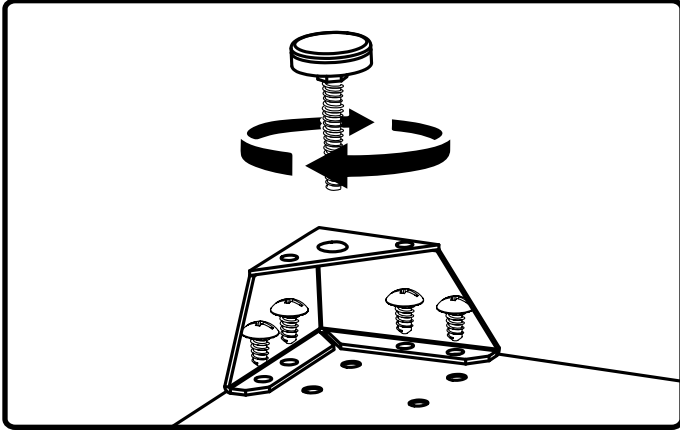

- 2** Install corner wall cabinets followed by remaining wall cabinets. See full instructions on [page 14](#).

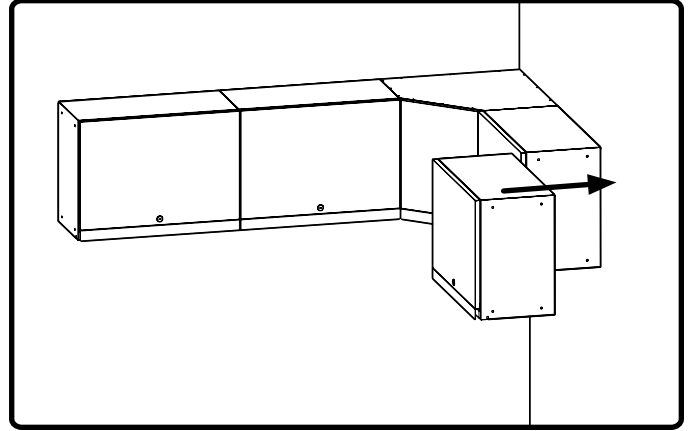

- 3** Install corner worktop supports and base cabinets. See [page 19](#).

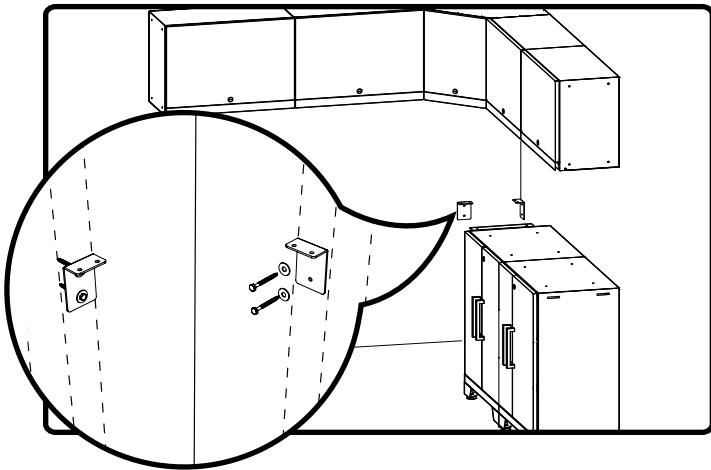

- 4** Install corner worktop. See [page 19](#).

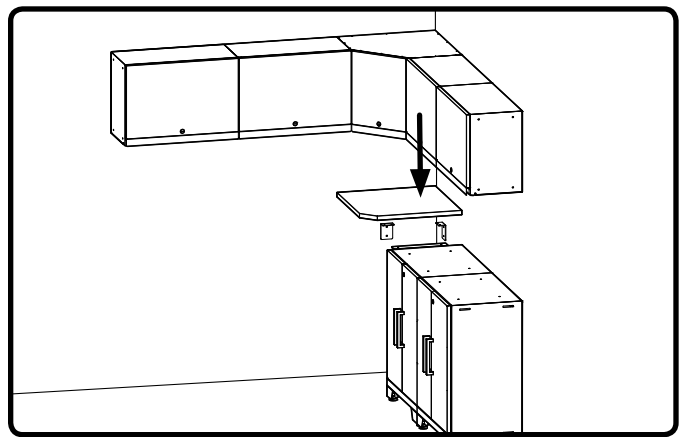

- 5** Position, secure and attach all remaining cabinets and worktops. See [pages 14, 15](#) and [17](#).

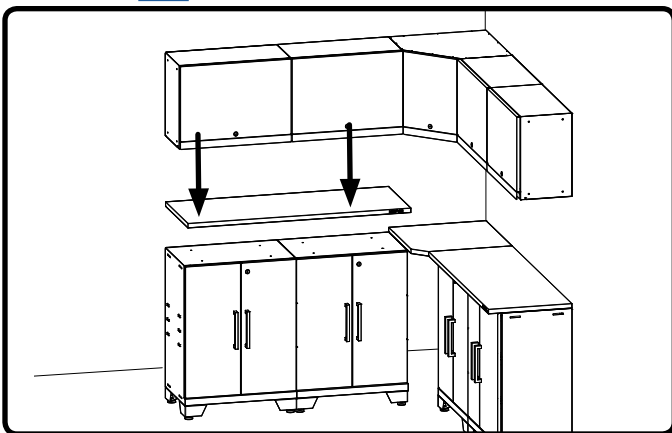

- 6**

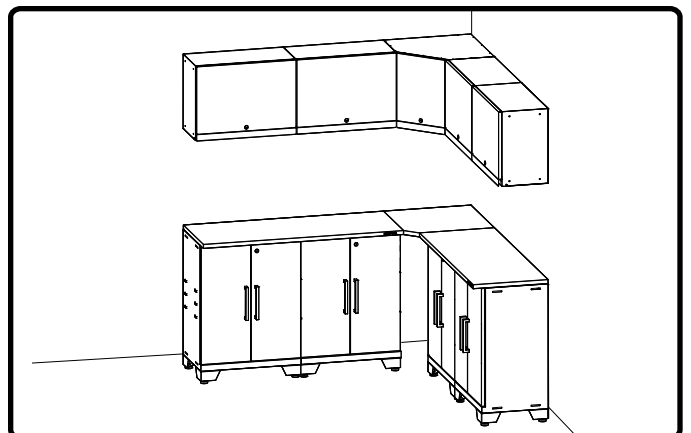

# Hanging Cabinets on Studded Wall



**Note:**  
Do not load cabinet without first securing to the wall.

## 1 Gather parts.

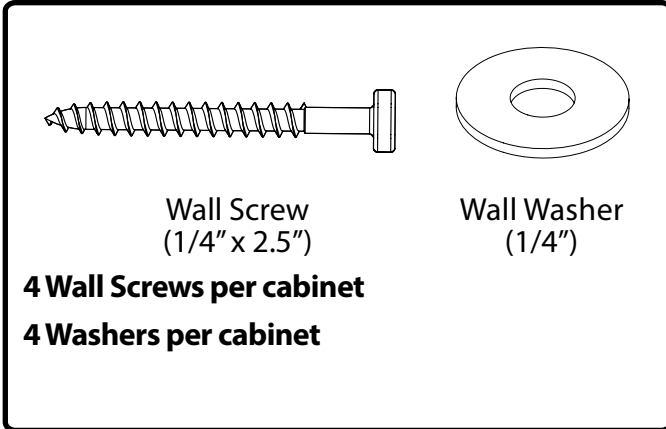

## 2 Use stud finder to locate the studs and mark a line on the wall with a pencil at desired height.

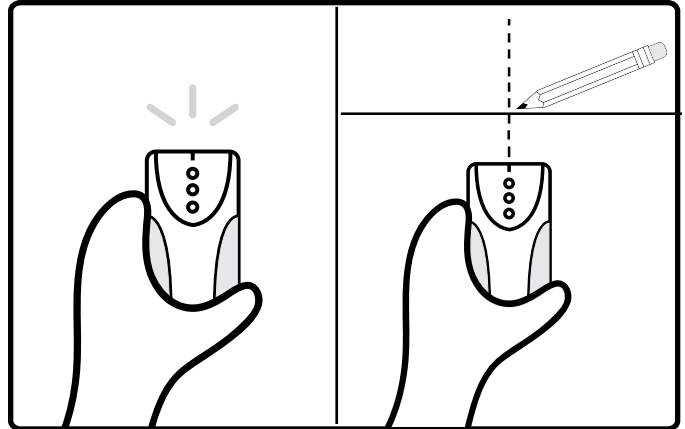

## 3 Begin by attaching locker to wall. Line up top of cabinet with pencil line(1), and pre-drill 3/16" (6mm) holes into studs through holes in cabinet(2). Use wall screws to secure to wall(3).

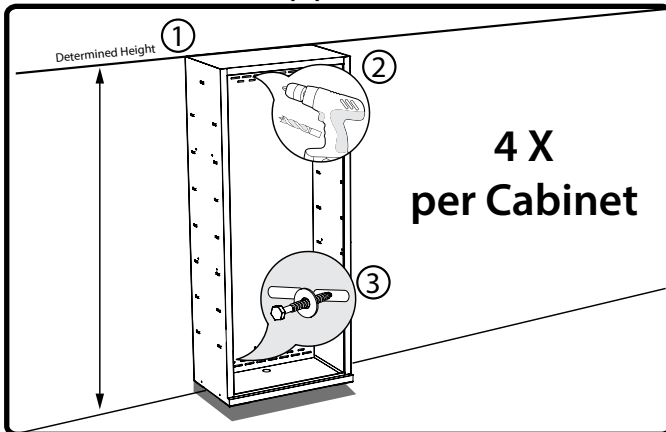

## 4 Attach remaining base cabinets (2), and wall cabinets(3) to wall using same method as locker cabinet(1) attachment.

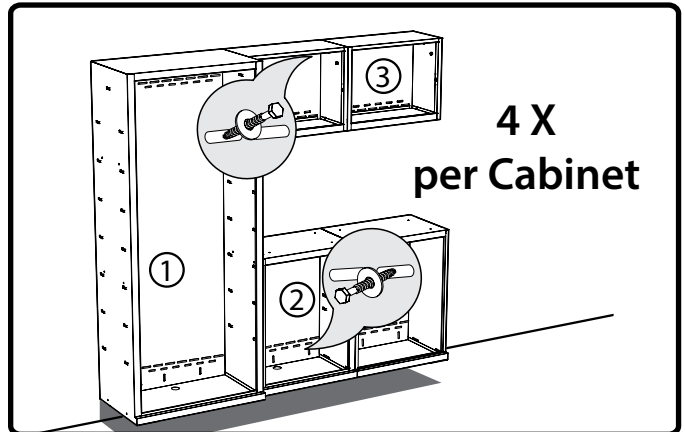

## 5 Finish by fastening cabinets together. See [page 15](#) for detailed instructions.

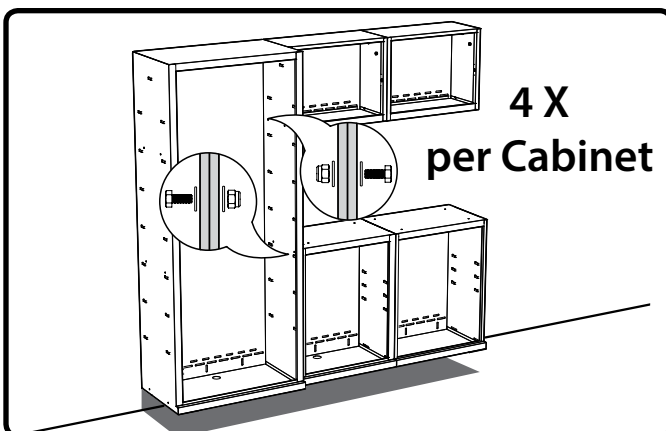

## i Masonry.

- Follow steps 3 to 5.
- Drill 4 pilot holes through the perforated strip with hammer drill & masonry bit.
- Use 4 x (2 1/4" x 1/4") Tapcon Concrete Anchor into wall. (Not Included)
- OR 4 x (#10 x 2") Screw with 3/16" masonry plug into wall. (Not Included)
- Follow Step 6.

# Hanging Cabinets on Slatwall

**Note: Slatwall Brackets** for use with standard 3" slatwall **Sold Separately**. Check with your slatwall supplier to determine the rated capacity of your slatwall. **DO NOT OVERLOAD.** **NewAge Slatwall Brackets are only compatible with standard 3" on center Slatwall.**

## **i** Parts Needed.

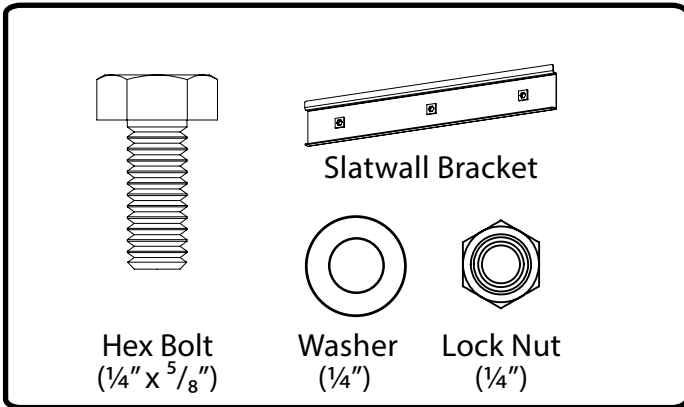

## **1** Insert bolts through slatwall bracket.

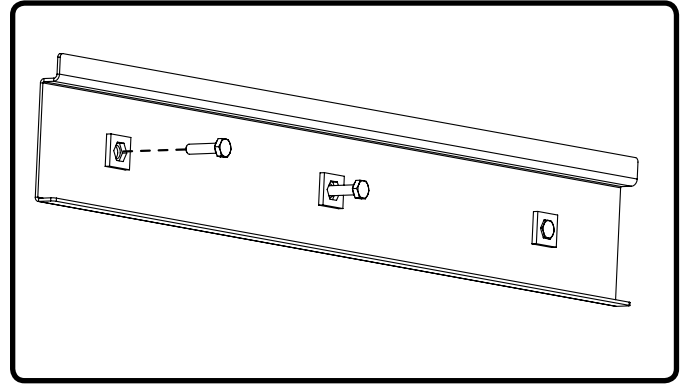

## **2** Attach bracket to slatwall at desired height.

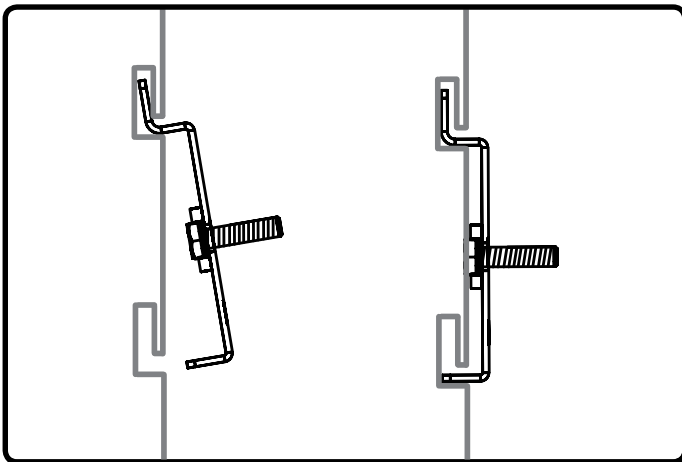

## **4** Align bolt with slots on back of cabinet and hang cabinet.

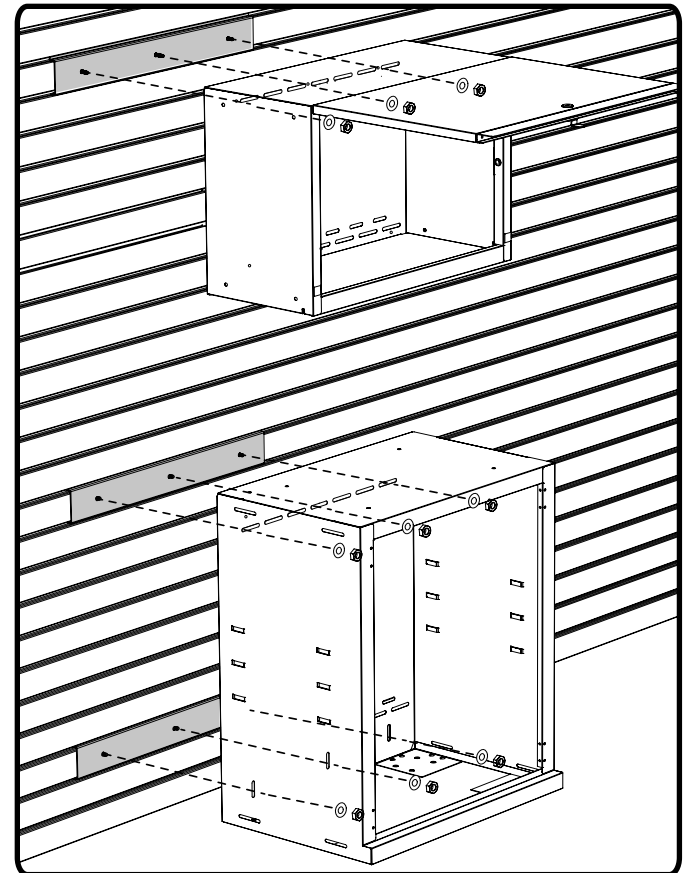

## **3** Bracket Placement. Brackets needed per cabinet. Wall - 1, Locker, Base and Tool - 2.

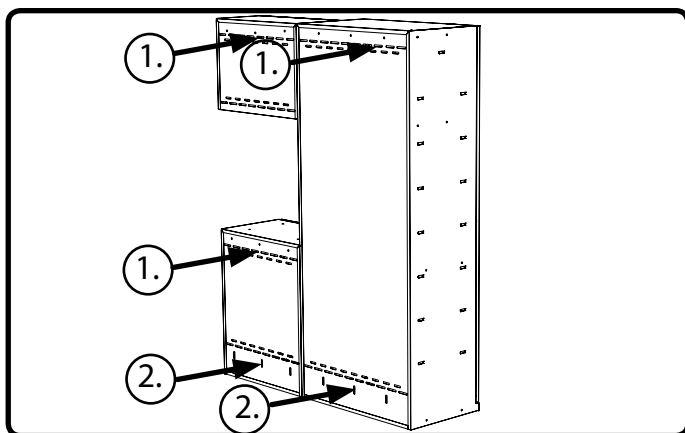

**Note:** For Locker cabinet attach second bracket 66" below first bracket. For Base cabinet attach second bracket 18" below first bracket.

# Securing Cabinets on Studded Wall



## Note:

Do not load cabinet without first securing to the wall.

- 1** Use stud finder to locate the studs and mark the wall with a pencil.

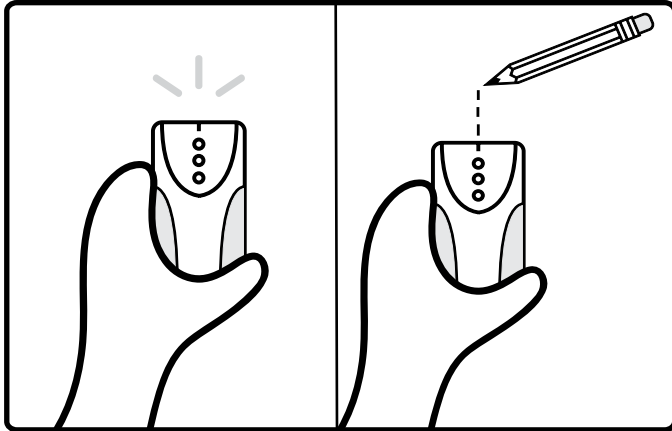

- 2** Gather parts.

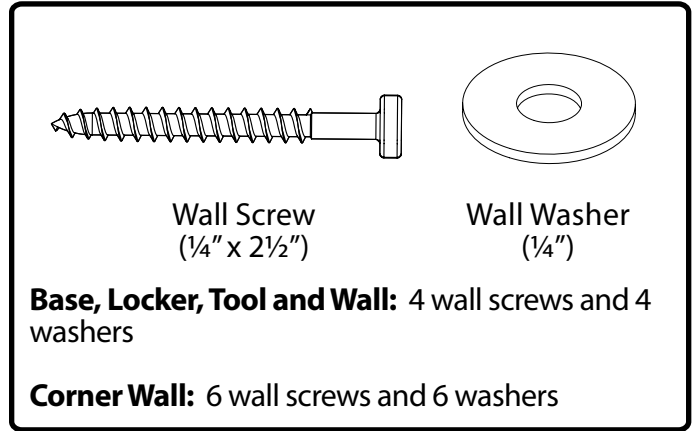

- 3** Place cabinet tight against the wall.

- 4** Align cabinet to stud marks.

- 5** Level cabinet.

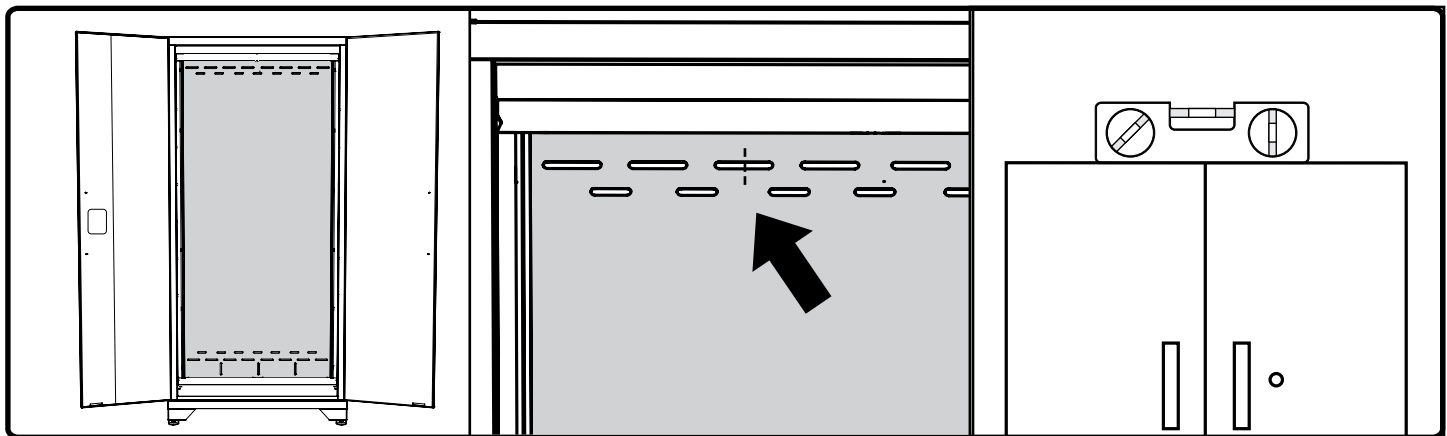

- 6** Pre-drill (4) 1/4" (6.5mm) then drill 4 wall screws and washers through perforated holes into studs.

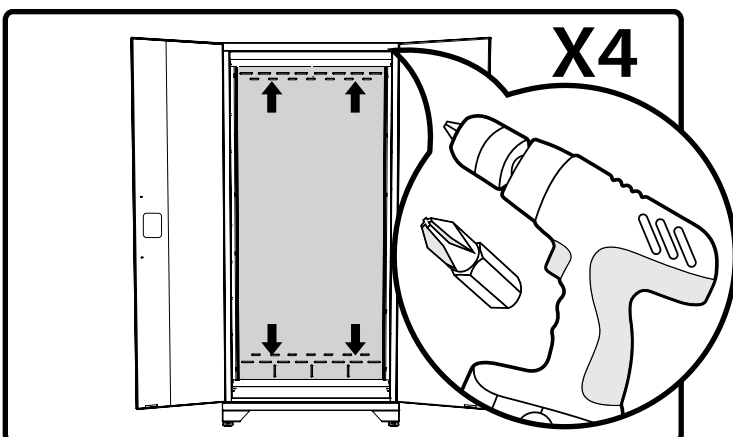

## **i** Masonry.

- Follow steps 3 to 5.
- Drill 4 pilot holes through the perforated strip with hammer drill & masonry bit.
- Use 4 x (2 1/4" x 1/4") Tapcon Concrete Anchor into wall. (Not Included)
- OR 4 x (#10 x 2") Screw with 3/16" masonry plug into wall. (Not Included)
- Follow Step 6.

# Fastening Cabinets

**Note:**

All drawers must be removed prior to fastening cabinets together. See [Page 22](#) for drawer removal instructions.

**1** Parts Needed.

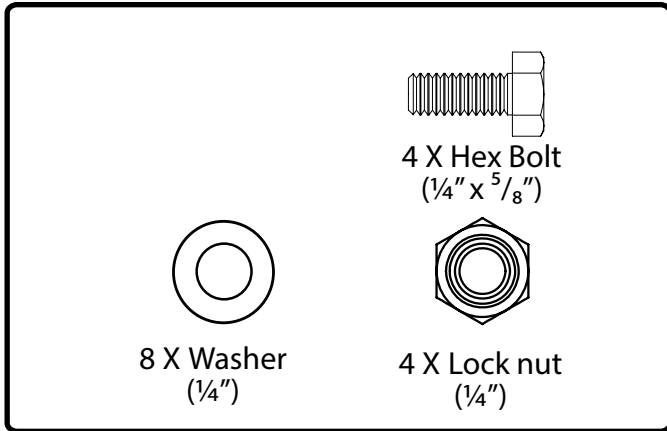

**2** Align bolts, tighten lightly.

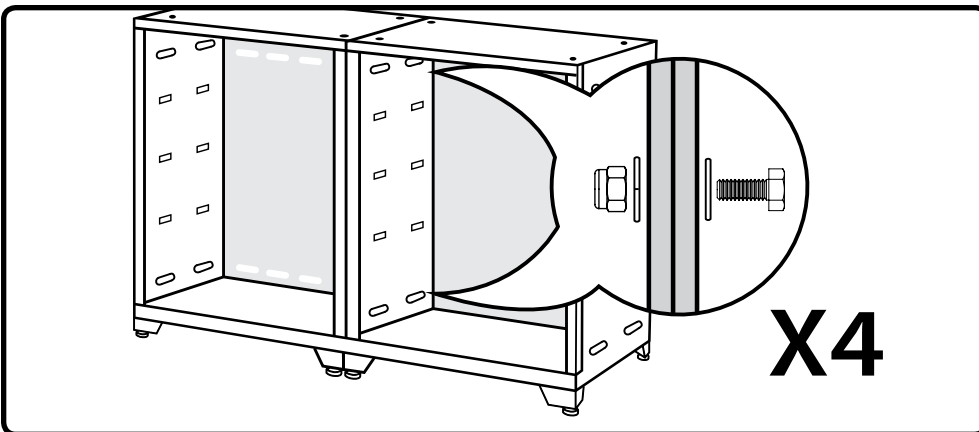

**3** Level cabinets and tighten all bolts.

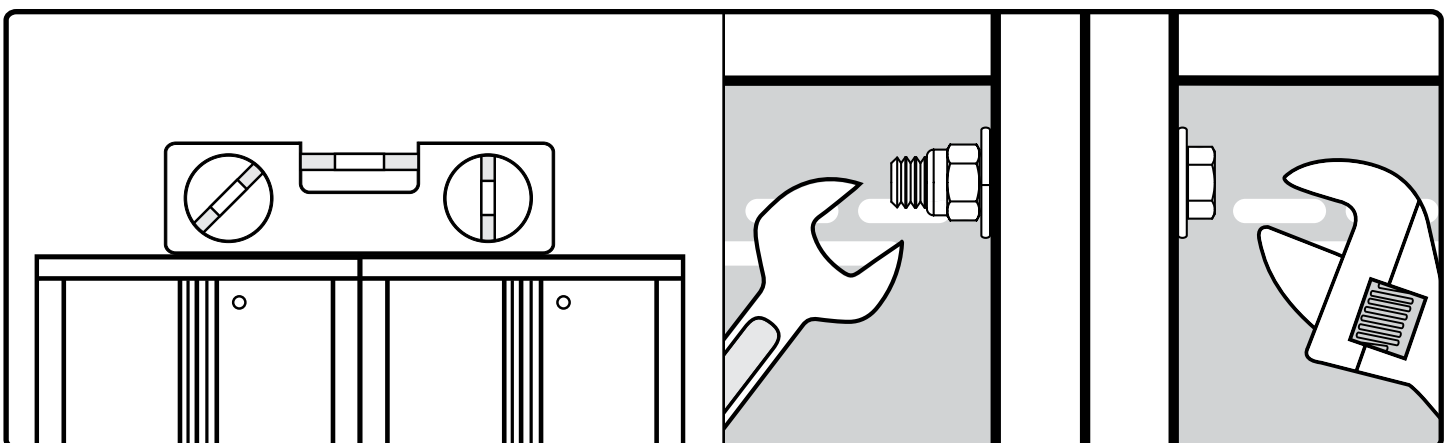

# Fastening Cabinets with Casters

## **i** Parts Needed.

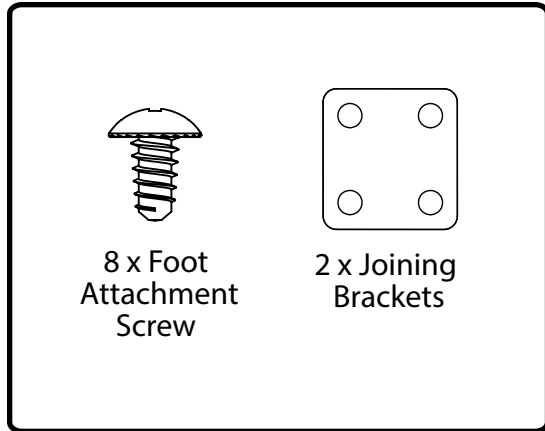

## **1** Open cabinets, remove any shelves, drawers or loose items.

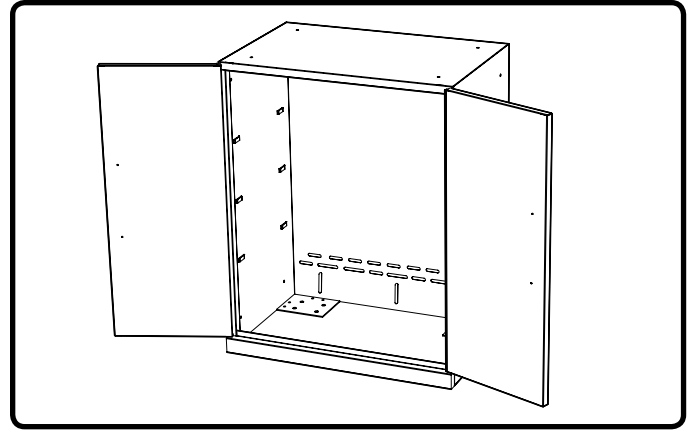

## **2** Flip cabinets and push sides together, locate holes on edges.

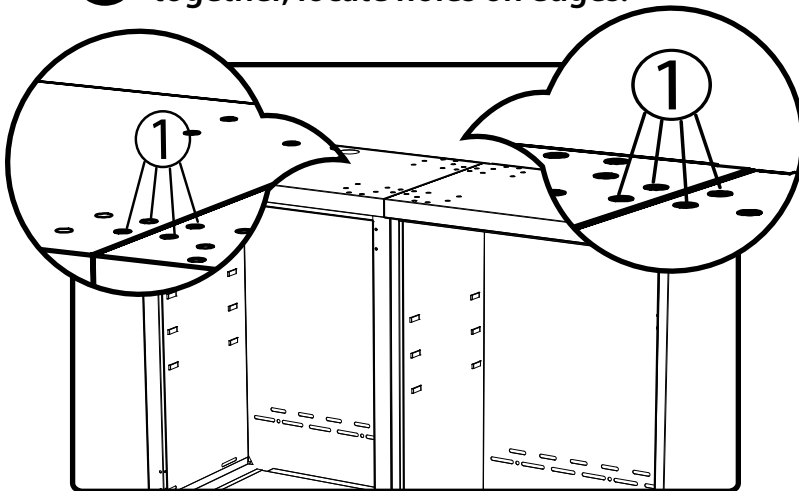

## **3** Align holes with joining plate and attach using foot attachment screws.

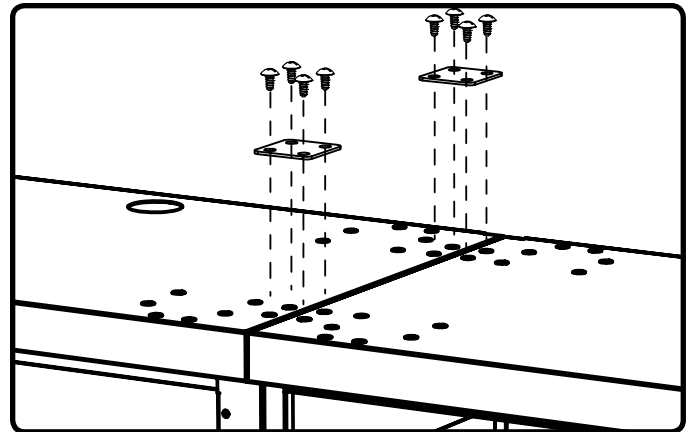

## **4** Attach casters and fasten cabinets together. See [pages 15.](#) & [21.](#)

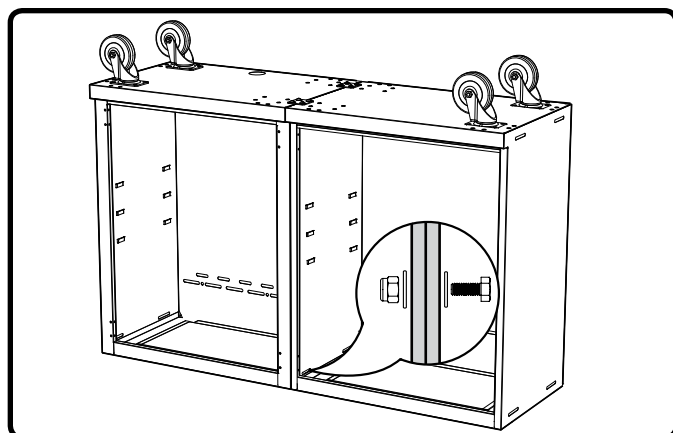

## **5**

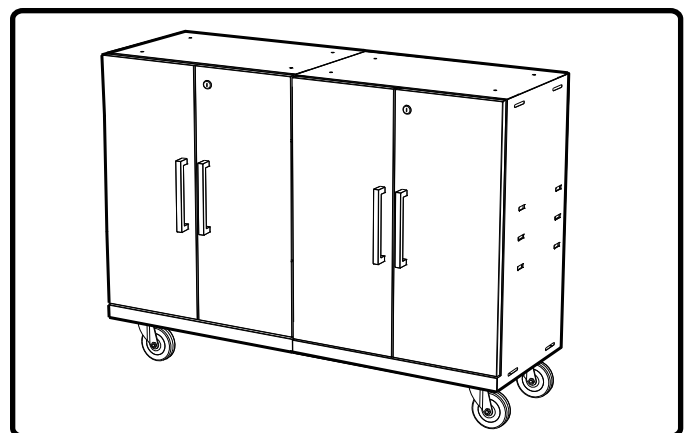



# Mounting the Worktop

## **i** Parts Needed.

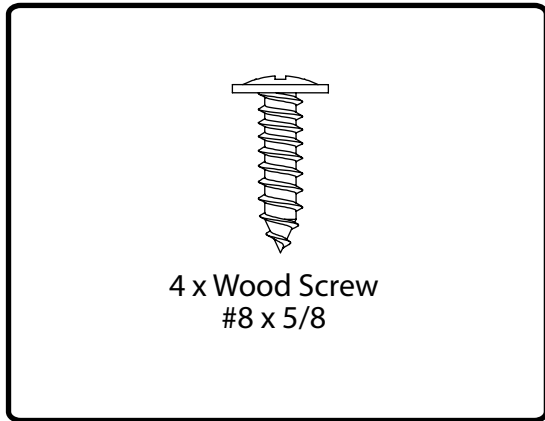

## **1** Place Worktop on cabinets. Locate the punch holes on the tops of the cabinets.

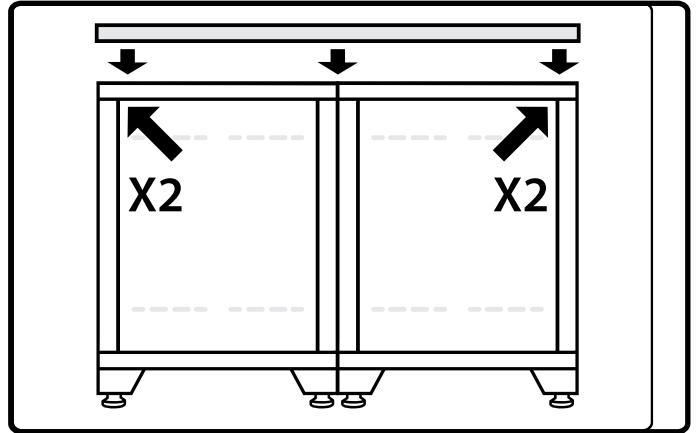

## **2** Drill into the worktop using the #8 x 5/8" wood screws.

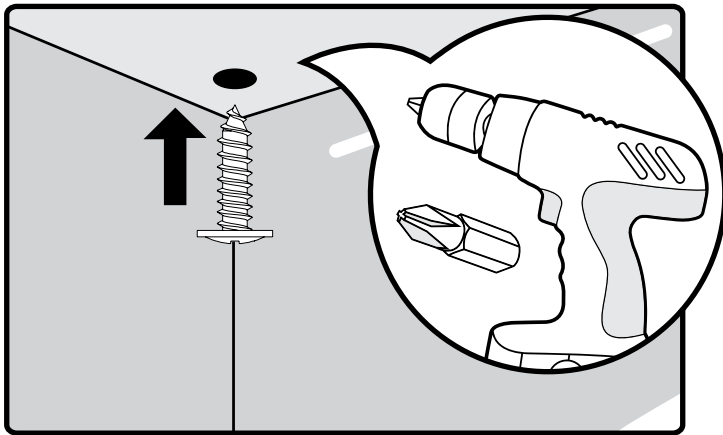

## **3**

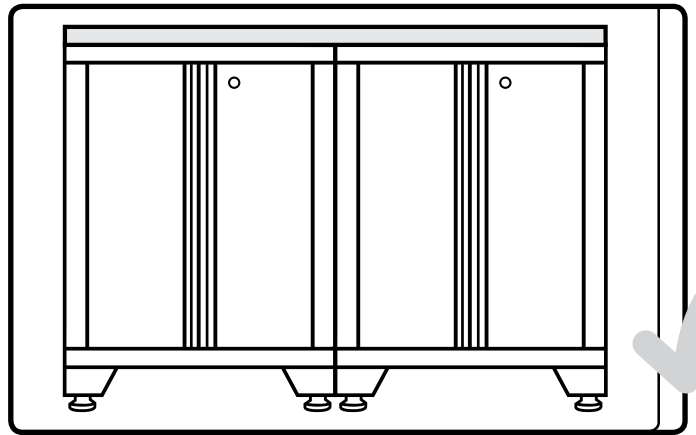

## **i** Optional: For locker support bracket. See [Page 18](#).

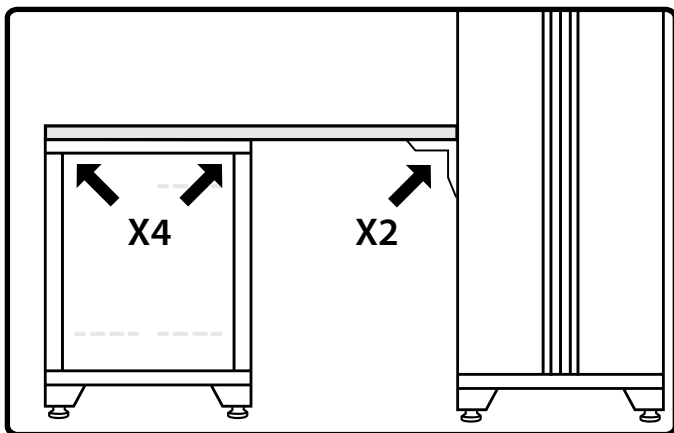

# Installing Worktop Side Support Bracket

**Note: Support Bracket included with Lockers**  
A support bracket is to be used if the worktop is added to the set without a secondary supporting base/tool cabinet.

## **i** Parts Needed.

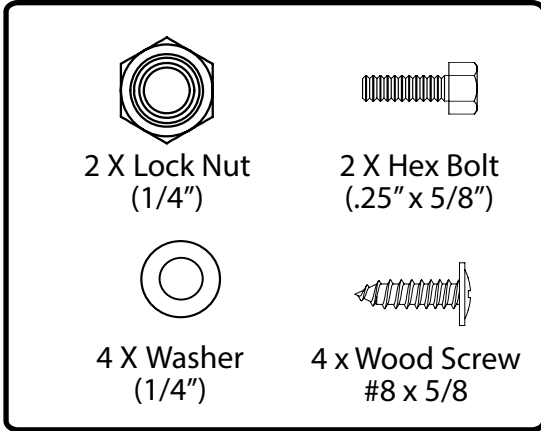

## **1** Open locker doors and locate holes on either side.

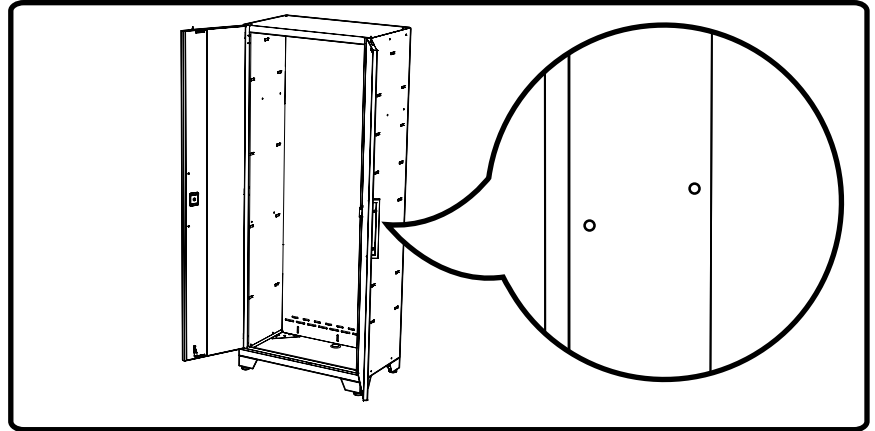

## **2** Align bracket holes with locker holes and insert hex bolts through holes.

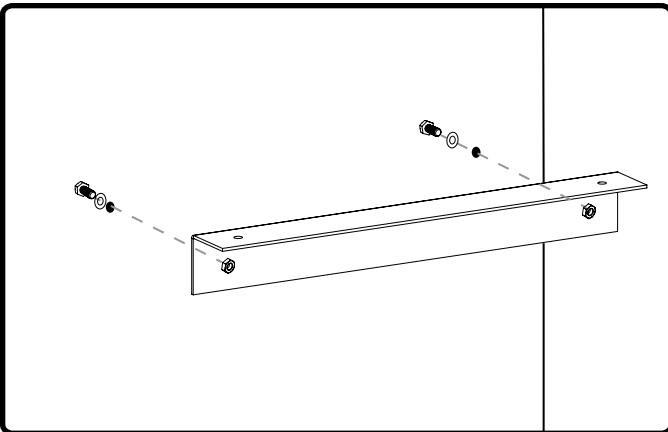

## **3** Tighten nuts & bolts.

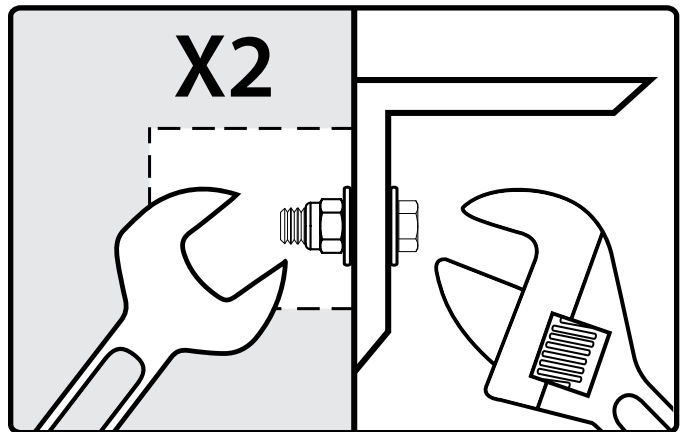

## **4** Use #8 x 5/8" wood screws and washers, provided in the locker packaging.

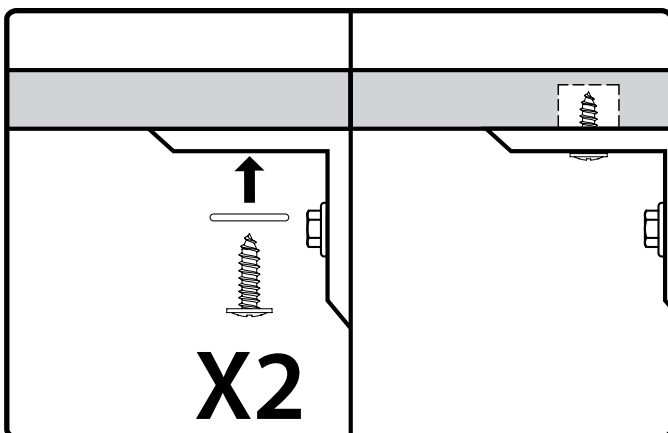

## **5**

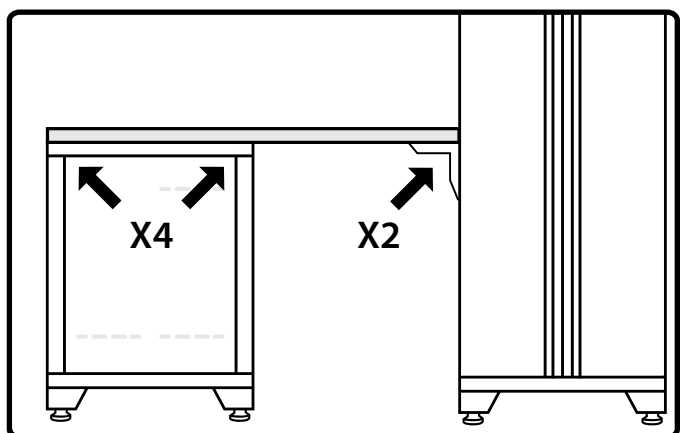

# Installing Corner Worktop

## Parts Needed.

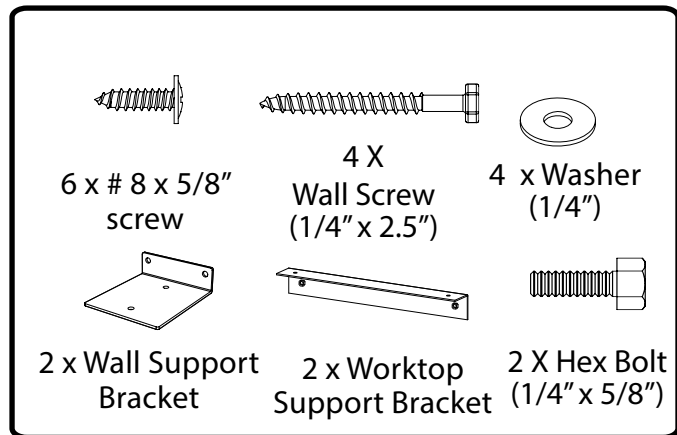

- 2** Position both cabinets in desired corner. Locate studs and mark a level pencil line at height of cabinets.

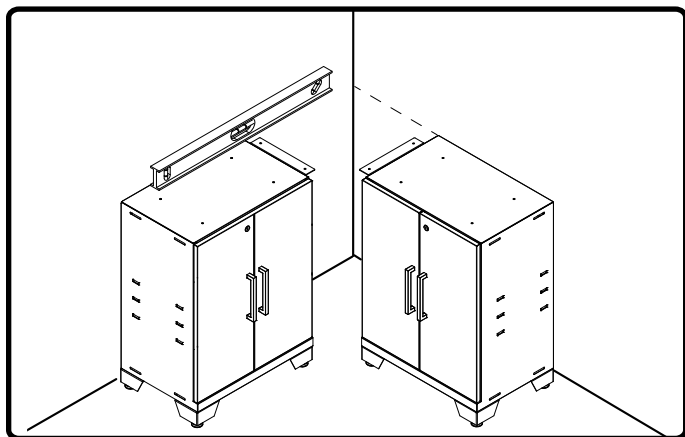

- 4** Position one cabinet into position and attach corner cabinets to brackets using #8 x 5/8" wood screws.

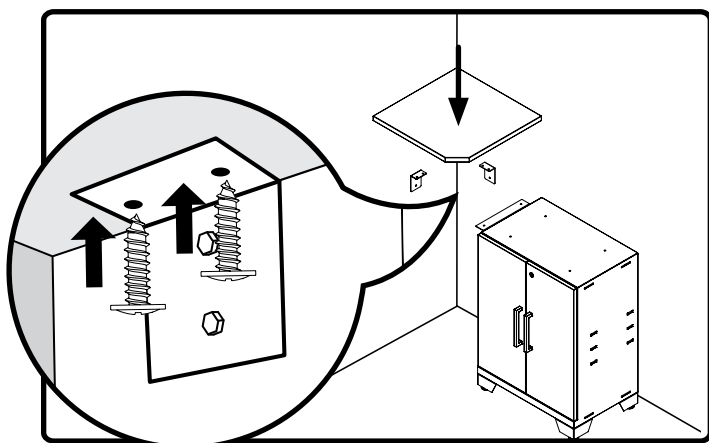

- 1** Install Side Support Brackets on the two base cabinets that will be adjacent to corner worktop. See Step 2 in side support brackets on [page 18](#).

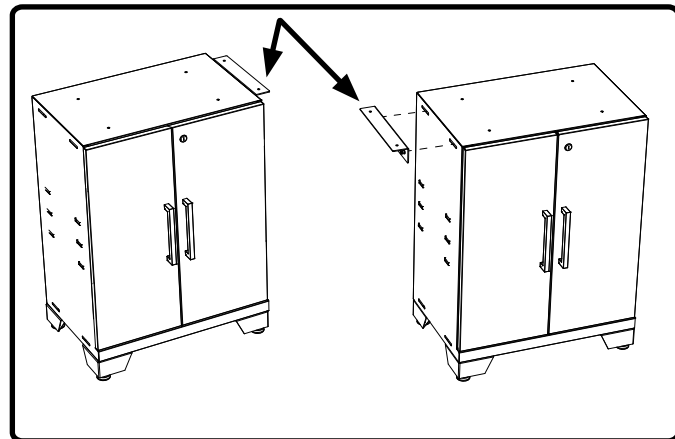

- 3** Align top of wall support bracket with pencil line. Pre-drill 1/4" (6.5mm) holes, then using (2) X 2.5 lag screw per bracket attach corner wall support brackets into wall studs.

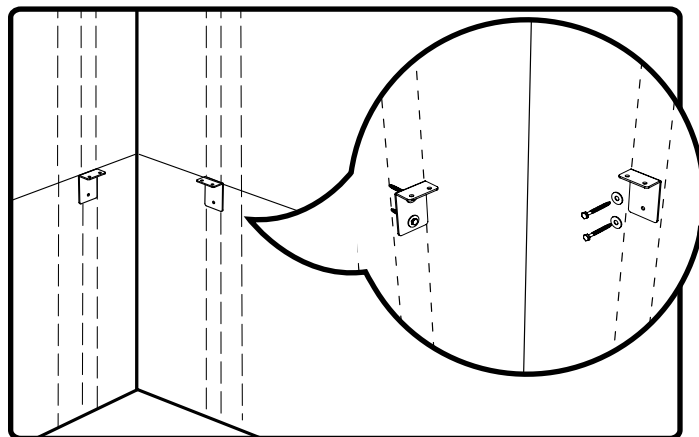

- 5** Attach remaining cabinets and countertops. See [page 17](#).

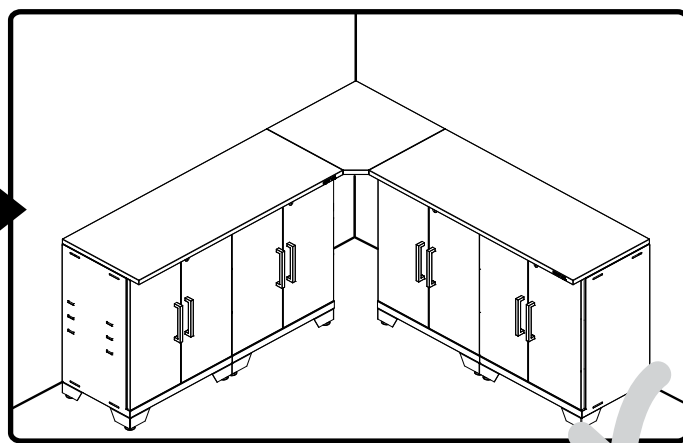

# Installing Feet

## **i** Parts Needed.

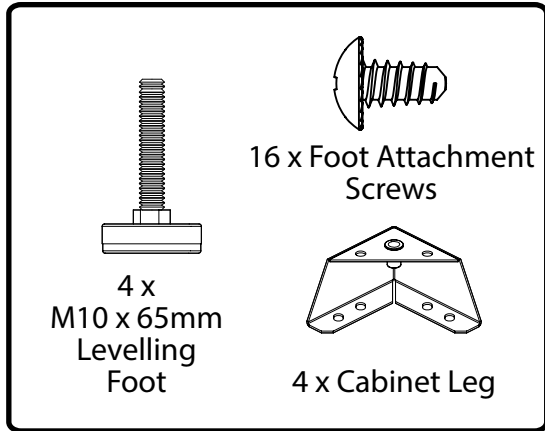

## **1** Open cabinet, remove any shelves or loose items.

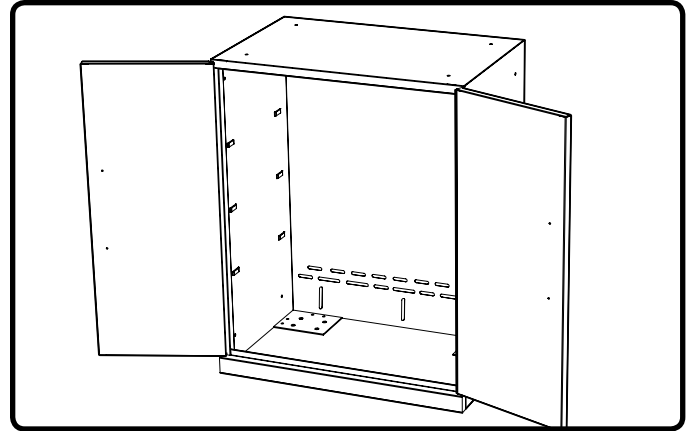

## **2** Flip cabinet upside down, locate holes at corners.

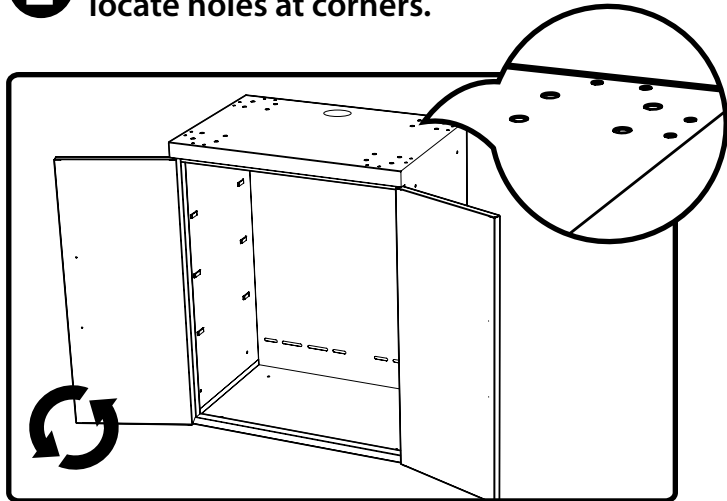

## **3** Align leg with edge of cabinet. Screw in 4 x Foot attachment screws & leveling foot.

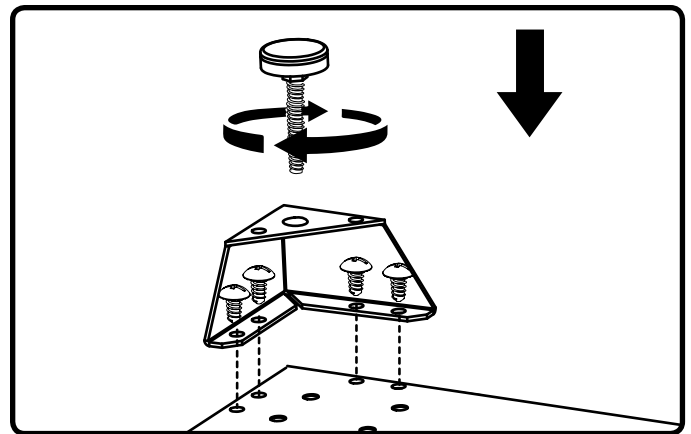

## **4** Repeat steps 3 for each corner.

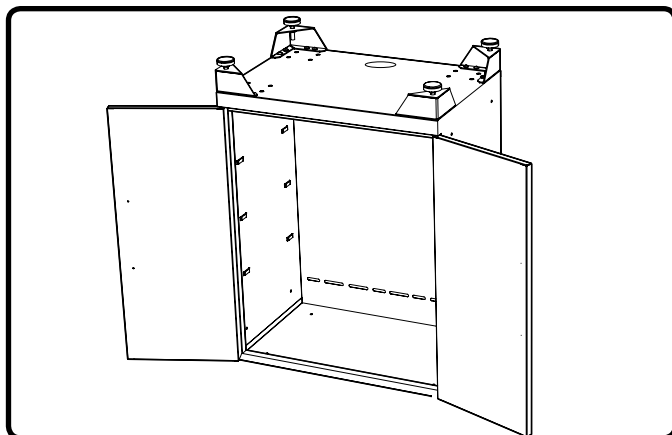

## **5** Stand & level feet.

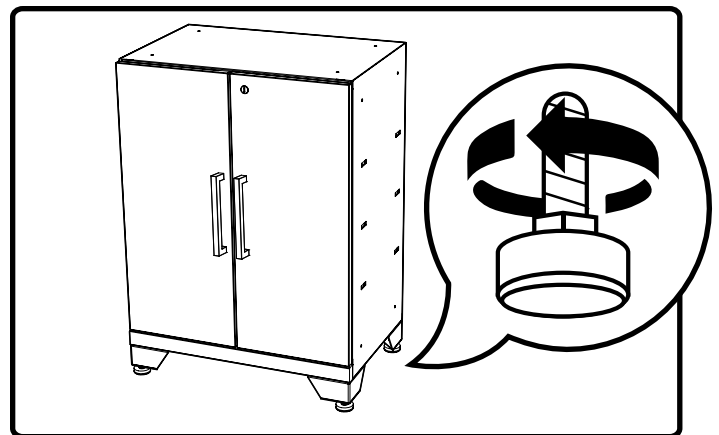

# Installing Casters

**Note:** Install casters with brakes on front of cabinet.

## **i** Parts Needed.

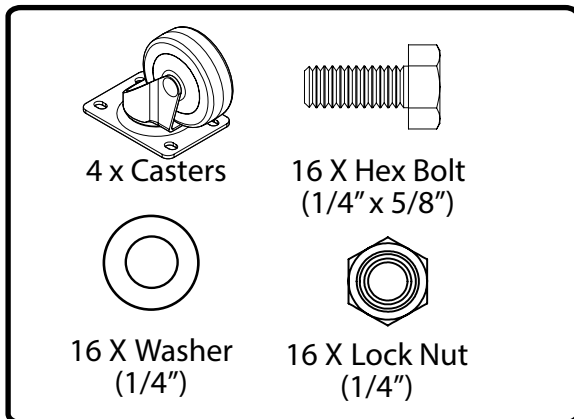

## **1** Open cabinet, remove any shelves, drawers or loose items.

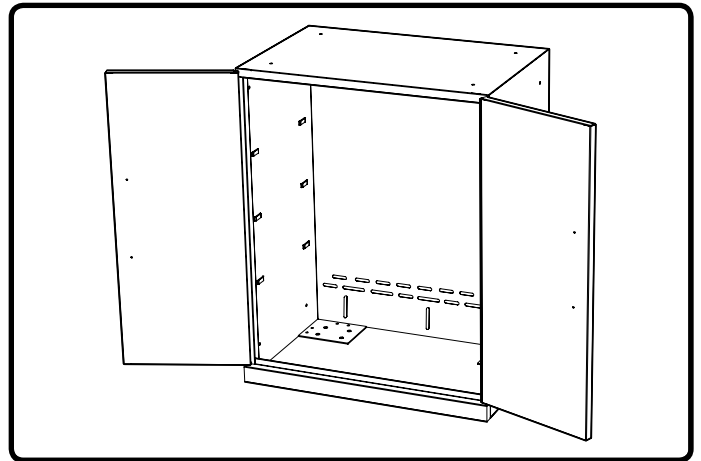

## **2** Flip cabinet upside down, locate holes forming a square.

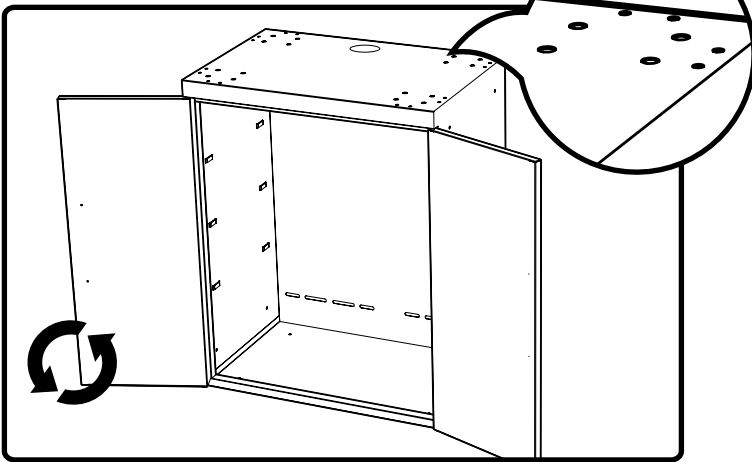

## **3** Align casters with holes. Attach with 4 hex bolts, washers, and nuts.

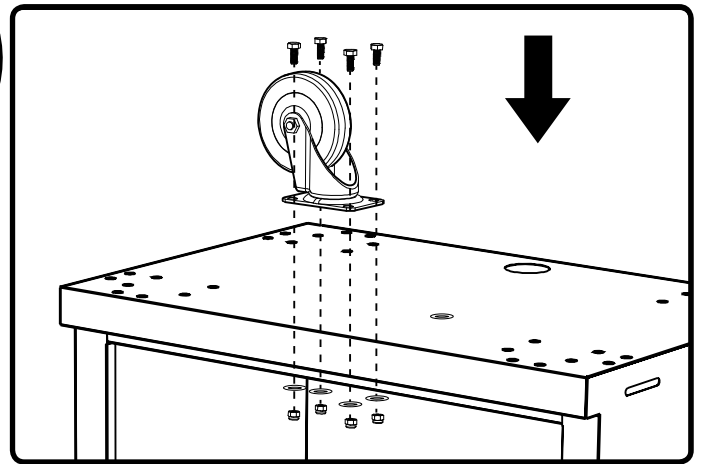

## **4** Repeat step 3 for each caster.

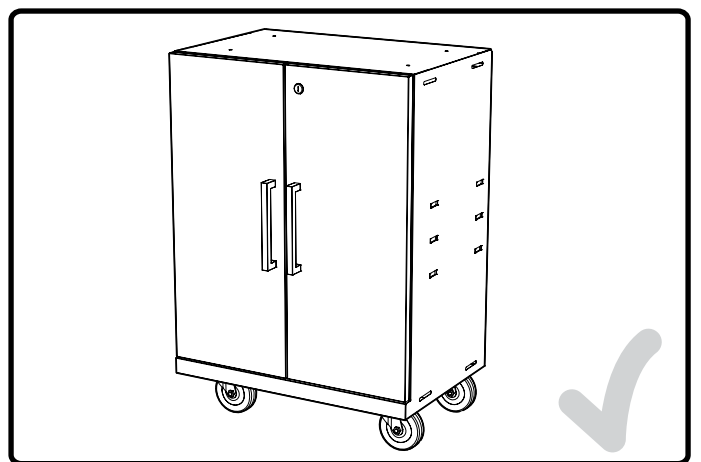
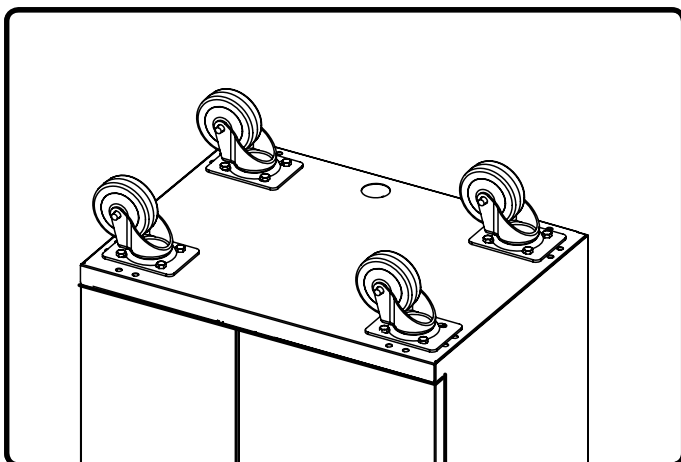

# Installing the Drawers

## Inserting Drawers.

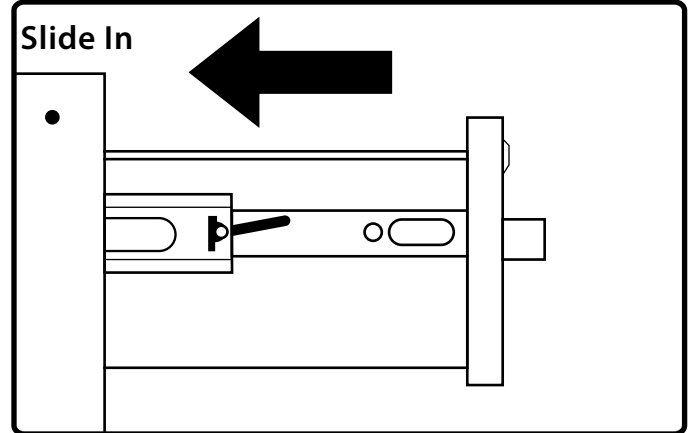
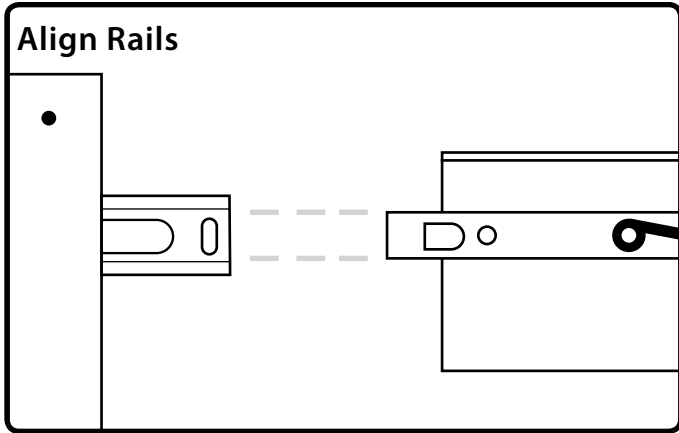

## Removing Drawers.

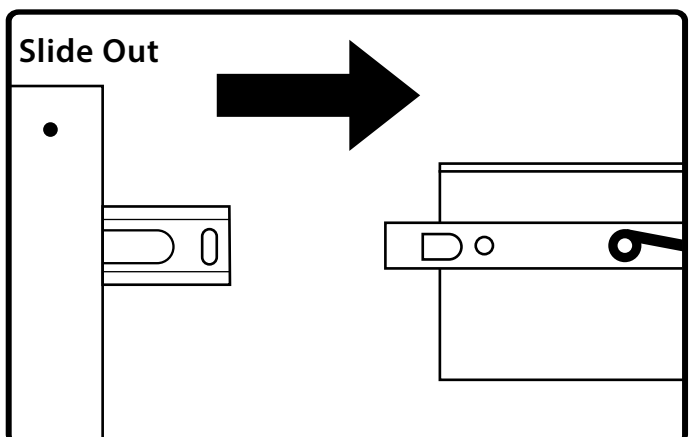
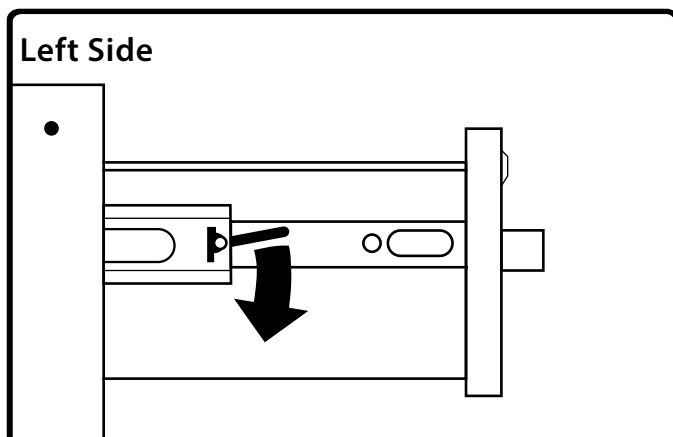
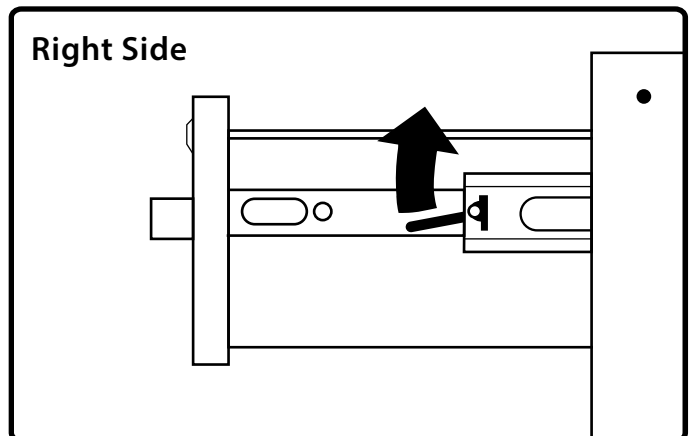
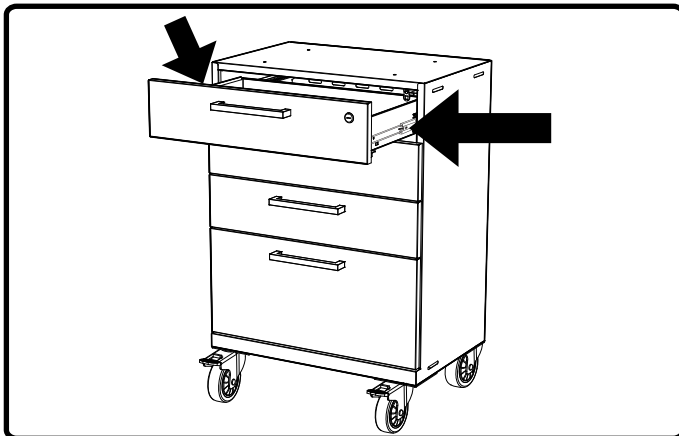

# Installing Handles

## 1 Parts Needed.

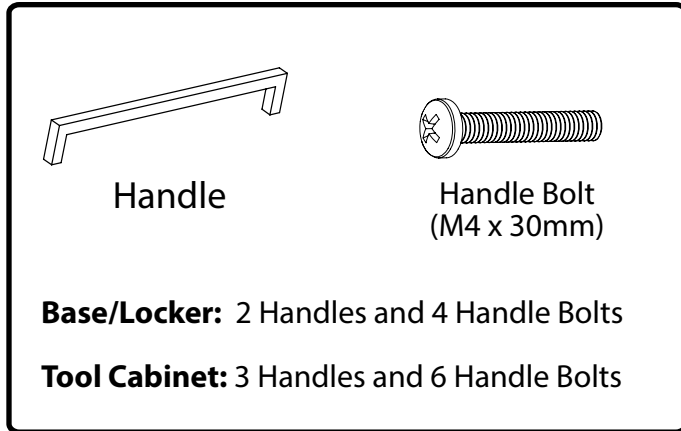

## 2 Align Handle to holes on doors or drawers.

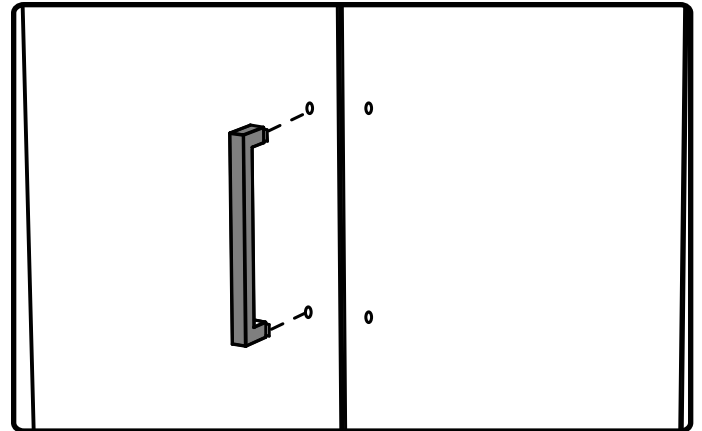

## 3 Screw in bolts using number a #2 Philips head screwdriver being careful not to overtighten bolts.

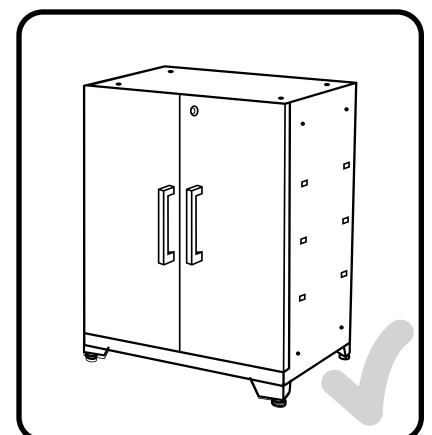
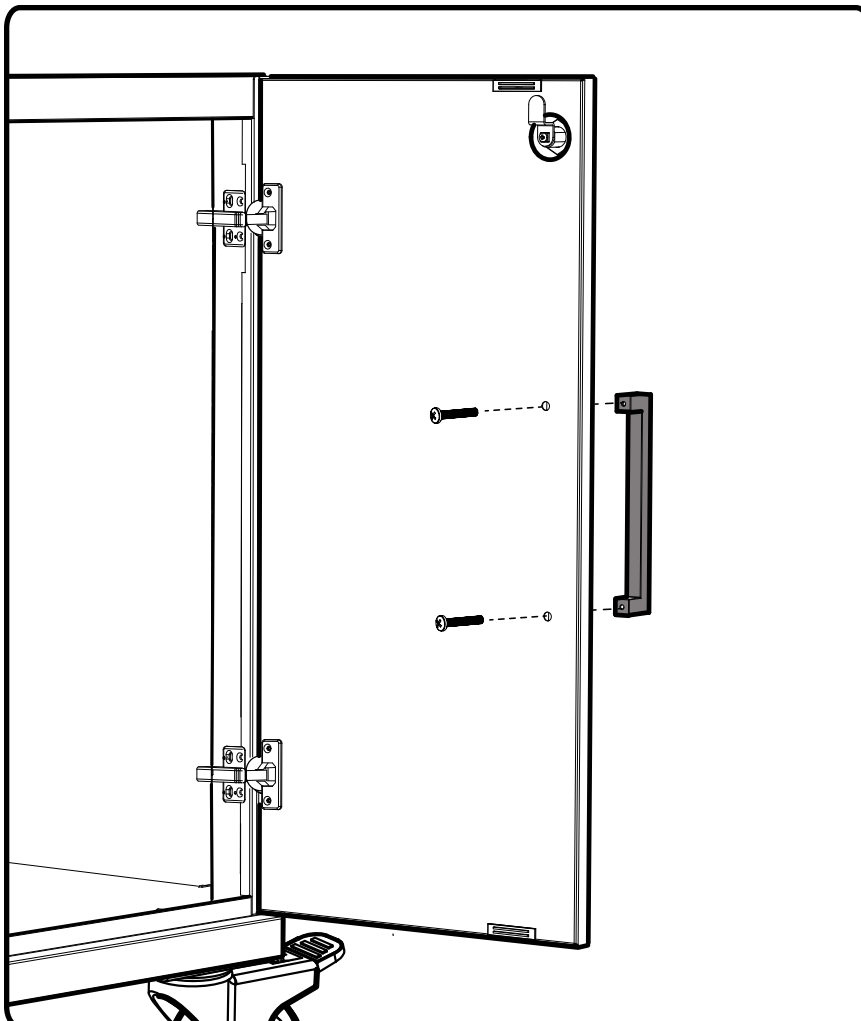

# Stacking Cabinets

## Parts Needed.

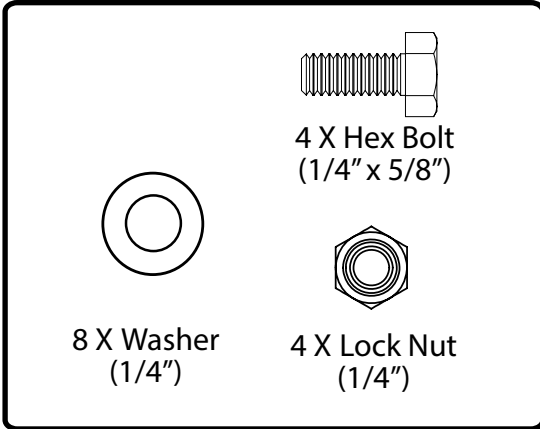

## **2** Locate punch holes on adjoining surface and insert bolts.

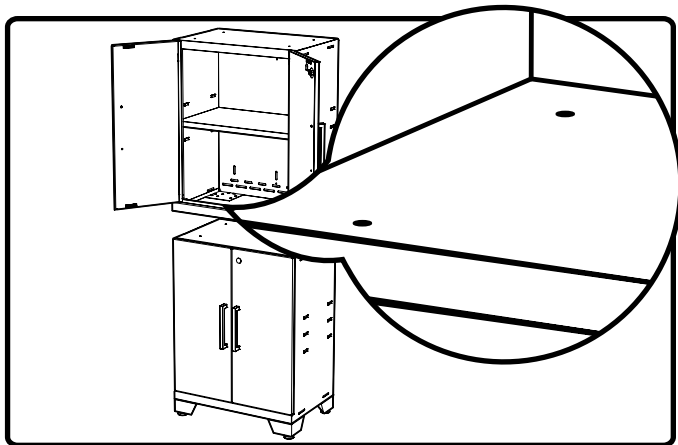

## **4** Tighten all bolts.

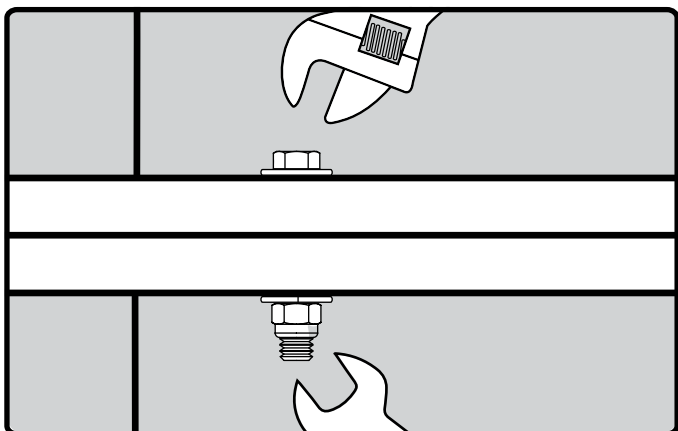

**Note:** Do not exceed weight capacity of feet. See [page 5](#). Installing cabinets on stacked cabinets is not recommended.

## **1** Position a second base cabinet on top of an existing base cabinet.

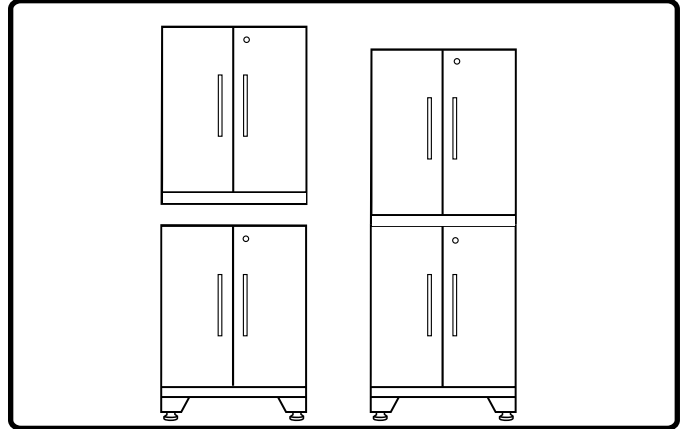

## **3** Attach cabinets using the supplied 1/4" x 5/8" hex bolts, washers, and nuts.

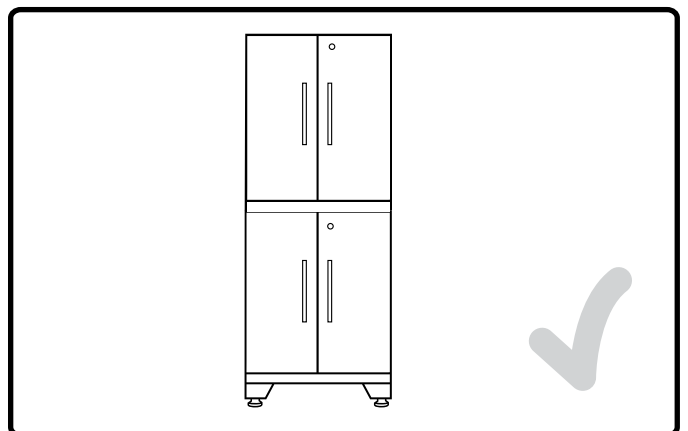
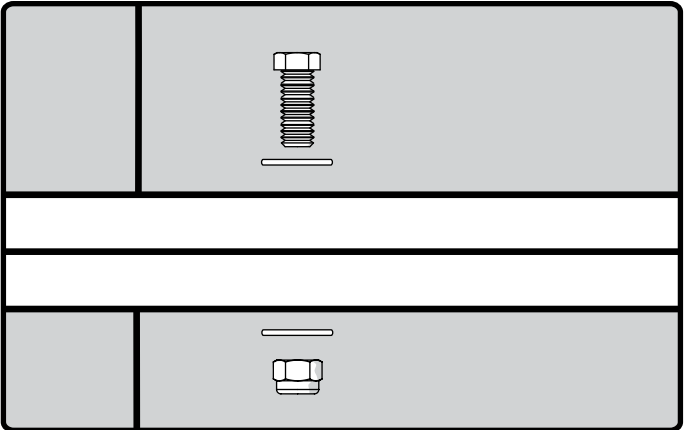



# Inserting Locker Utility Rod

**1** Tilt Rod at a slight angle.

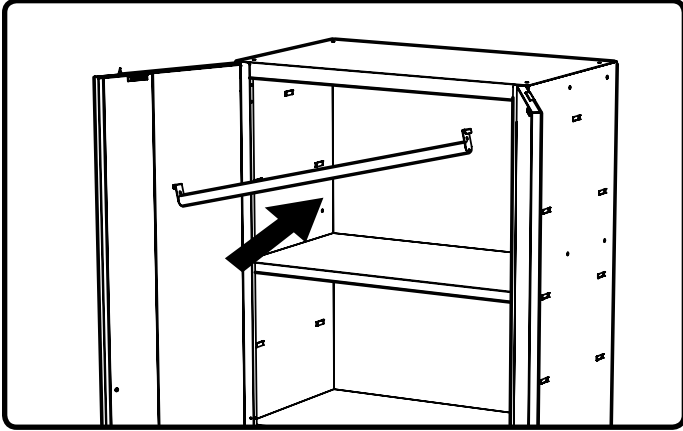

**2** Insert and bring to horizontal position above slots in wall.

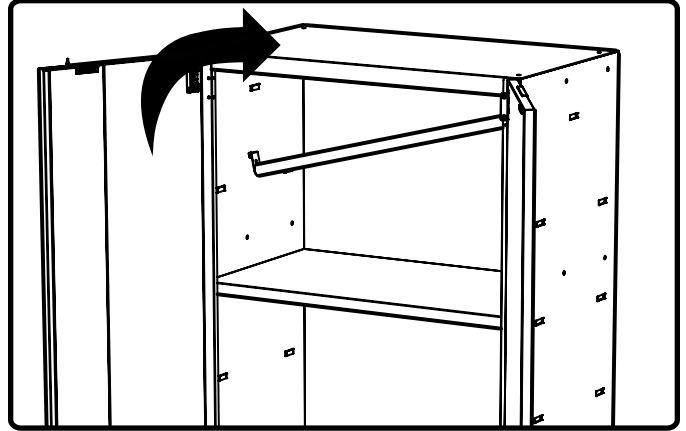

**3** Ensure Rod tabs engage in slots on side panel when lowering into position.

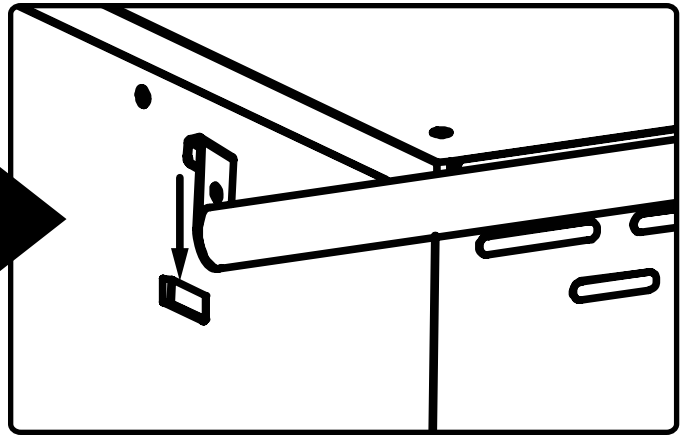
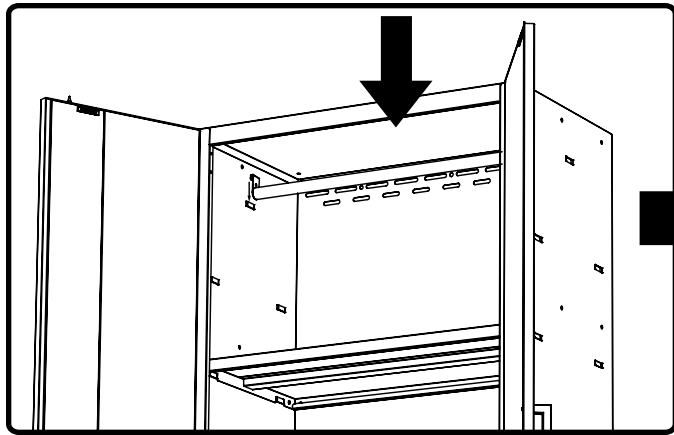

**4**

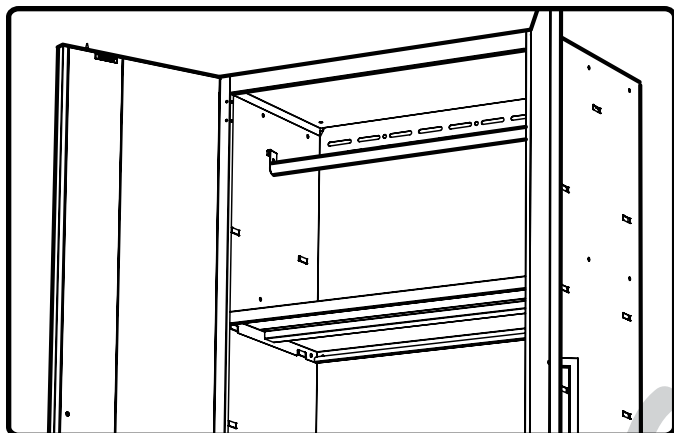

# Inserting Cabinets Shelves

**1** Stand cabinet up.

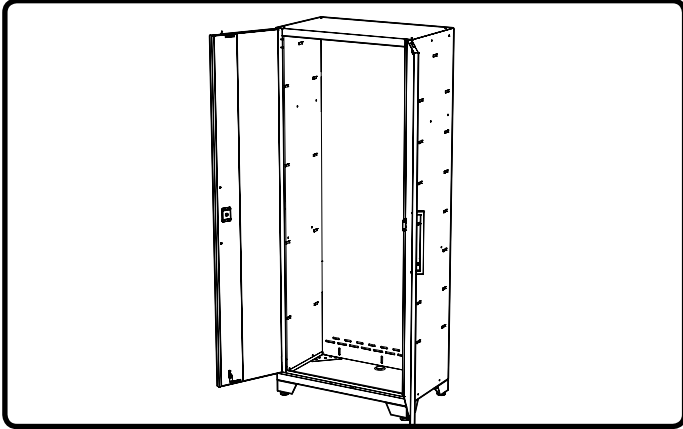

**2** Insert shelf at a slight angle.

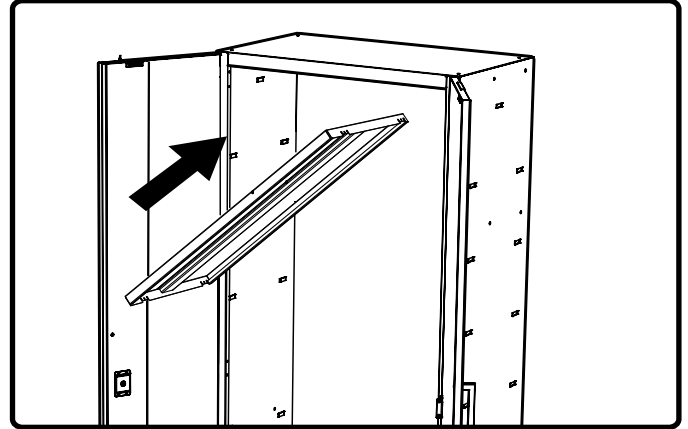

**3** Rotate shelf to horizontal position.

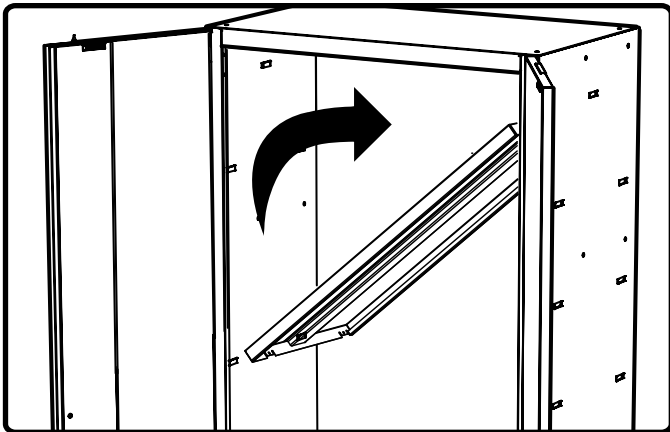

**4** Push shelf down into grooves.

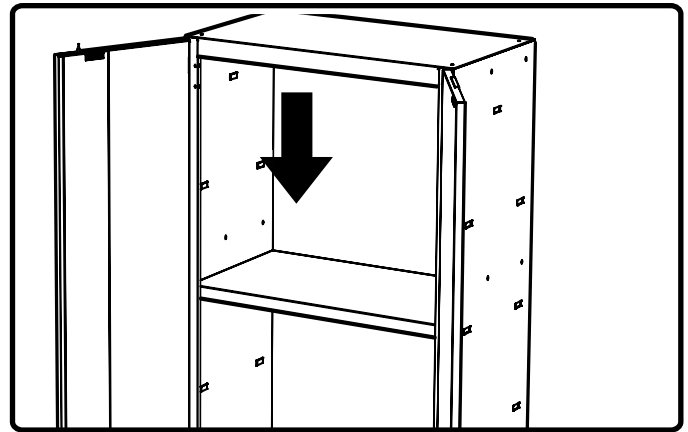

**5** Ensure shelf tabs engage in slots of side panel when lowering into position to secure.

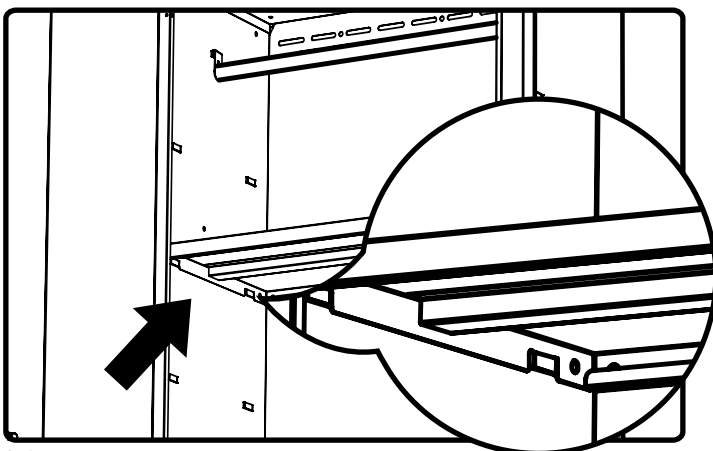

**6** Insert remaining shelves.

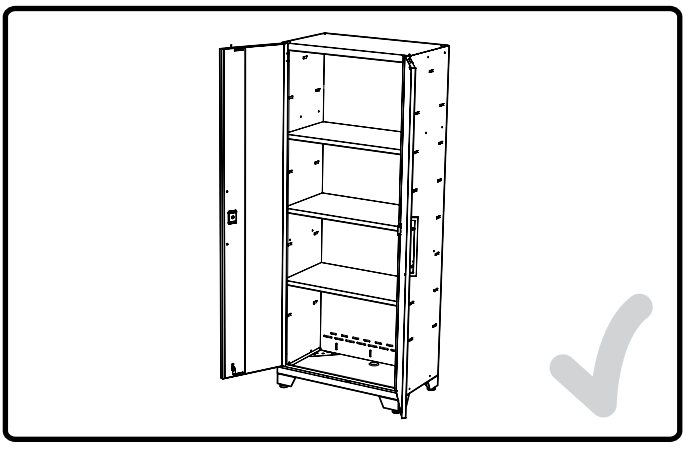

# Utility Access

- 1** Insert rubber grommet into cut-out hole in bottom panel.

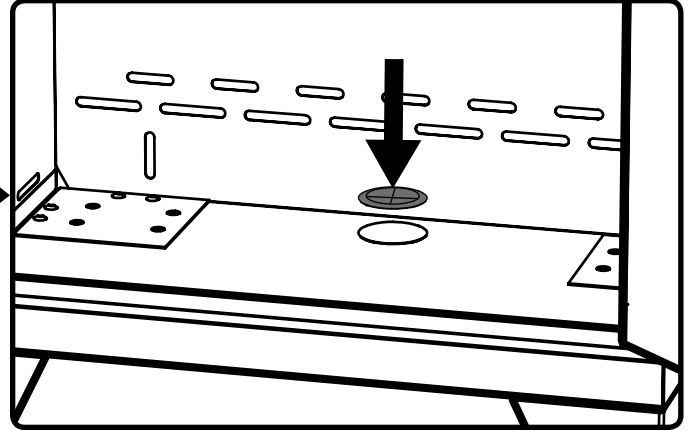
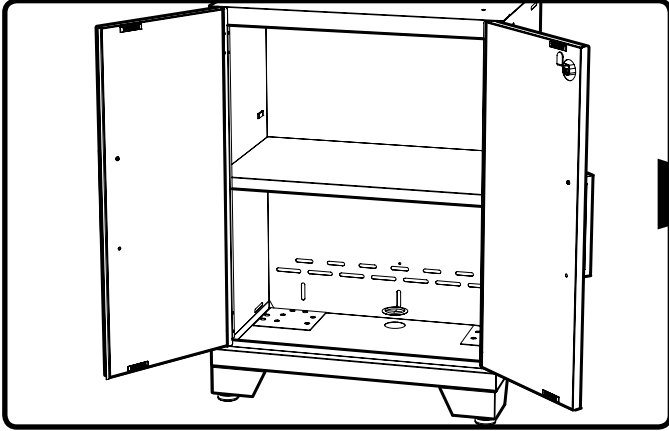

- 2** Using box knife cut along perforation in rubber grommet to create hole. Utility hole allows easy access to electrical outlet.

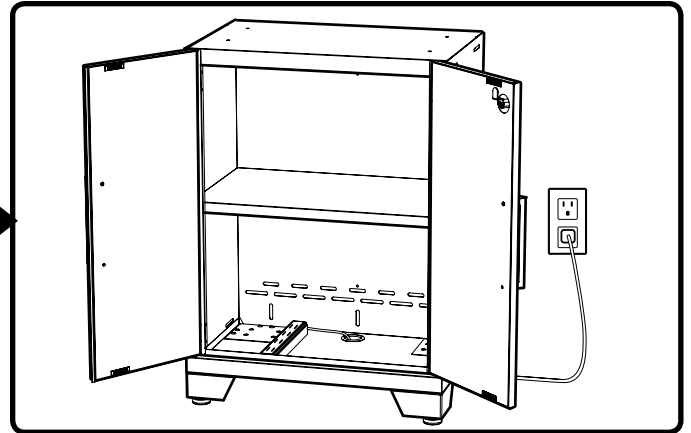
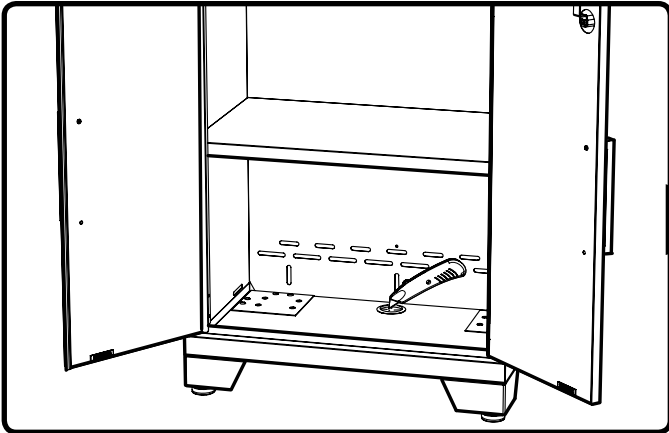

# Magnetic Racing Stripe

**Note:** Racing stripe not available with diamond plate doors.

The Racing Stripe can be installed on either door. To remove stripe follow steps 1-3.

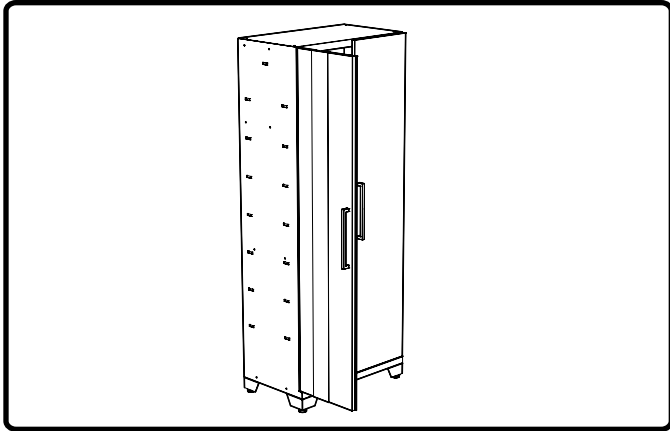

**1** Remove the 2 plastic plugs holding in the racing stripe at the top of door.

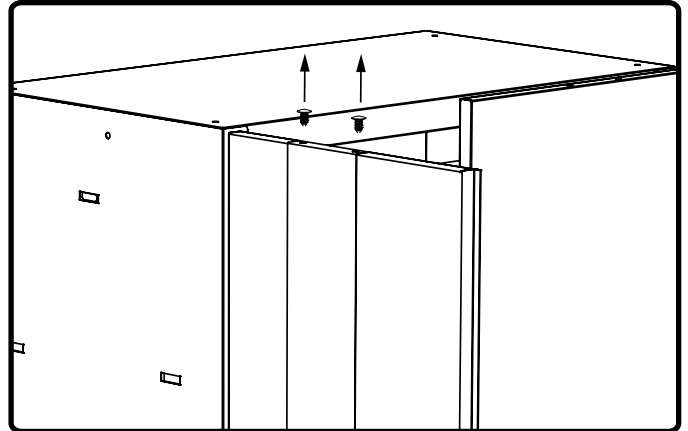

**2** Tilt stripe off top of door.

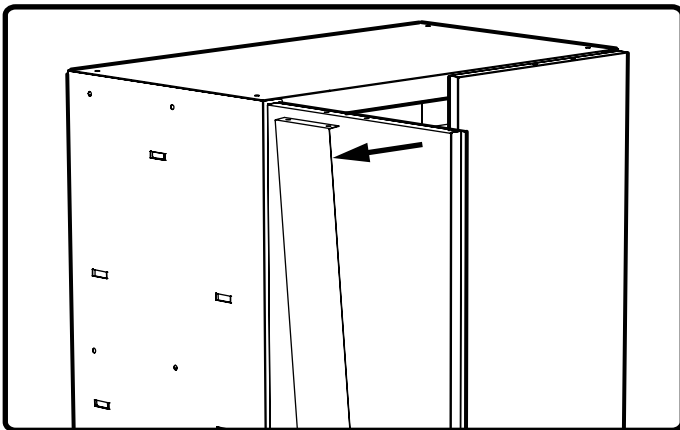

**3** Lower and remove from slot on bottom of door.

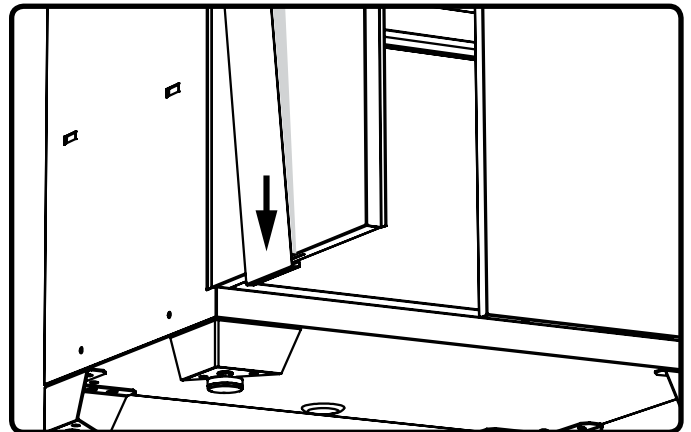

**4** Attach Racing Stripe on opposite door following reverse order.

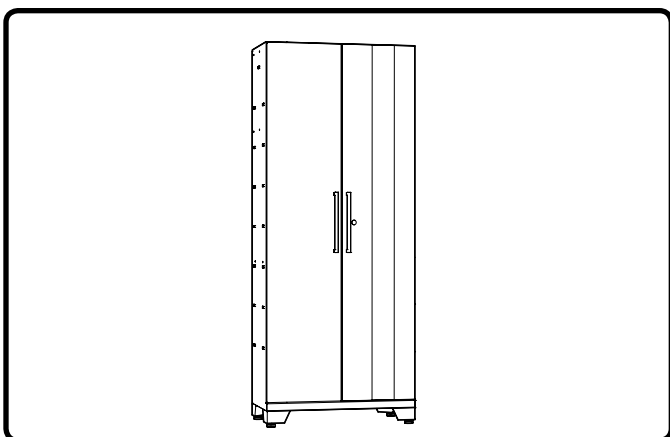

**i** **HANDLE WITH CARE:** Racing Stripe can easily bend and crease.

# Manufacturer Warranty Limited Lifetime

When this product is installed, operated and maintained according to the instructions attached to or furnished with the product, NewAge Products Inc. will replace the defective product or parts if the part fails as a result of defective materials or workmanship for the Lifetime of the product.

## **NEWAGE PRODUCTS INC. WILL NOT PAY FOR:**

1. Service calls to correct the installation of any NewAge products or to instruct you how to use or install them.
2. Damage resulting from improper handling or shipping of products, or products damaged by accident, misuse, abuse, fire, flood, improper installation, acts of God, neglect, corrosion, modification or mishandling.
3. Products damaged by improperly loading beyond the specified maximum weight capacity outlined in the instructions provided with the product.
4. Repairs or replacement when your product is used in other than normal, single-family household use, such as a commercial environment, or handled in anyway inconsistent with the installation instructions included with the product.
5. Cosmetic damage, including scratches, dings, dents or cracks in paint that do not affect the structural or functional capability of the product.
6. Surfaces damaged due to chemical interaction resulting in corrosion of paint or metal.
7. Replacement parts for NewAge products outside Canada and the United States.
8. Replacement keys or locking mechanisms.
9. Loss of product contents due to theft, fire, flood, accident or acts of God.
10. Shipping or freight fees to deliver replacement products or to return defective products.
11. Any labor costs during the limited warranty period.



## **DISCLAIMER OF IMPLIED WARRANTIES; LIMITATION OF REMEDIES**

IMPLIED WARRANTIES, INCLUDING TO THE EXTENT APPLICABLE WARRANTIES OF MERCHANTABILITY OR FITNESS FOR A PARTICULAR PURPOSE, ARE EXCLUDED TO THE EXTENT LEGALLY PERMISSIBLE. ANY IMPLIED WARRANTIES THAT MAY BE IMPOSED BY LAW ARE LIMITED TO ONE YEAR, OR THE SHORTEST PERIOD ALLOWED BY LAW. SOME STATES AND PROVINCES DO NOT ALLOW LIMITATIONS OR EXCLUSIONS ON HOW LONG AN IMPLIED WARRANTY OF MERCHANTABILITY OR FITNESS LASTS, SO THE ABOVE LIMITATIONS OR EXCLUSIONS MAY NOT APPLY TO YOU. THIS WARRANTY GIVES YOU SPECIFIC LEGAL RIGHTS, AND YOU MAY ALSO HAVE OTHER RIGHTS WHICH VARY FROM STATE TO STATE OR PROVINCE TO PROVINCE

**Thank you for purchasing a NewAge Product!**

**Please give us a call or visit online if you have any questions.**

**Call 1.877.306.8930; for UK 0800.031.4069; e-mail at [info@newageproducts.com](mailto:info@newageproducts.com)**