



ITEM #0103339

# MODULAR REFRIGERATOR

MODEL #BG179B

Master Forge & M Design® is a registered trademark of LF, LLC. All rights reserved.

Français p. 16  
Español p. 31



**IMPORTANT**  
READ THIS USER'S MANUAL  
PRIOR TO CONNECTING  
POWER AND USE.



**IMPORTANT**  
SAVE THESE INSTRUCTIONS  
FOR FUTURE REFERENCE. IF  
YOU ARE ASSEMBLING THIS  
UNIT FOR SOMEONE ELSE,  
GIVE THIS MANUAL TO HIM  
OR HER TO SAVE FOR  
FUTURE REFERENCE.



**WARNING**  
BEFORE THE REFRIGERATOR  
IS USED, IT MUST BE  
PROPERLY POSITIONED,  
LEVEL AND INSTALLED AS  
DESCRIBED IN THIS MANUAL.  
READ THIS MANUAL  
CAREFULLY.

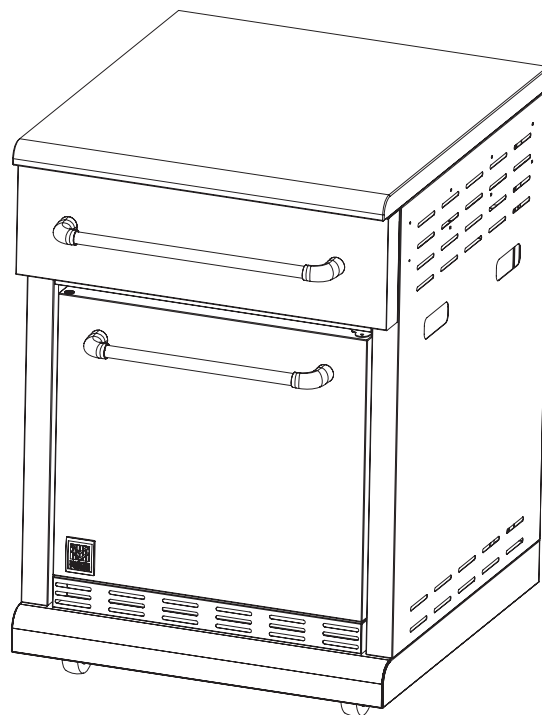

### ATTACH YOUR RECEIPT HERE

Serial Number \_\_\_\_\_ Purchase Date \_\_\_\_\_



**Questions, problems, missing parts?** Before returning to your retailer, call our customer service department at **1-800-963-0211**, 8 a.m. - 6 p.m., EST, Monday - Thursday, 8 a.m. - 5 p.m., EST, Friday.

**TABLE OF CONTENTS**

---

**Safety Information.....3**

**Installation Instructions.....4**

**Reverse Refrigerator Door .....5**

**Care and Maintenance.....9**

**Troubleshooting .....11**

**Technical Data and Wiring Diagram.....13**

**Warranty.....14**

**Exploded View.....15**

**Replacement Parts List.....15**

## SAFETY INFORMATION

---



To reduce the electrical shock or injury when using the refrigerator, follow basic precautions including the following:

**Remove all packaging before using this unit.**

**! DANGER !**

- Plug into a grounded 3-prong GFI outlet. Do not remove grounding prong, do not use an adaptor, and do not use an extension cord.
- It is recommended the refrigerator be plugged into it's own circuit. Use receptacles that cannot be turned off by a switch or pull chain.
- Never clean refrigerator parts with flammable fluids. These fumes can create a fire hazard or explosion. Do not store or use gasoline or other flammable vapors and liquids in the vicinity of this or any other appliance. The fumes can create a fire hazard or explosion.
- Before proceeding with cleaning and maintenance operations, make sure the power cord of the unit is disconnected.
- Do not connect or disconnect the electric plug when your hands are wet.
- Unplug the refrigerator or disconnect power before cleaning or servicing. Failure to do so can result in electrical shock or death.
- Do not attempt to repair or replace any part of your refrigerator unless it is specifically recommended in this manual. All other servicing should be referred to a qualified technician.

**! DANGER !**

- To ensure proper ventilation for your refrigerator, the front of the unit must be completely unobstructed. Choose a well-ventilated area with temperatures above 40°F (5°C) and below 105°F (40°C). This unit must be installed in an area protected from the elements.
- The refrigerator should not be located directly next to other sources of high heat.
- The refrigerator must be installed with all electrical connections in accordance with state and local codes. A standard electrical supply (cfl, 115 V AC only, 60 Hz), properly grounded in accordance with the National Electrical Code and local codes and ordinances is required.
- Do not kink or pinch the power supply cord of refrigerator.
- The circuit breaker size should be 15 amperes.
- **It is important for the refrigerator to be level in order to work properly.** You may need to make several adjustments to level it.
- Never allow children to operate, play with or crawl inside the refrigerator.
- Do not use solvent-based cleaning agents or abrasives on the interior. These cleaners may damage or discolor the interior.
- Do not use this apparatus for other than its intended purpose.



**Use only Ground Fault Circuit Interrupter (GFCI) protected circuit with this appliance.**

## INSTALLATION INSTRUCTIONS

---

### Before Using Your Unit

- Remove the exterior and interior packing.
- Before connecting the unit to the power source, let it stand upright for approximately 2 hours. This will reduce the possibility of a malfunction in the cooling system from handling during transportation.
- Clean the interior surface with lukewarm water using a soft cloth.

### Setting the Temperature Control

- Your unit has only one control for regulating the temperature in the compartment. The temperature control is located on the upper side of the compartment.
- The first time you turn the unit on, set the temperature control to "7."
- The range of the temperature control is from position "0" to "7." **"1" is warmer and "7" is cooler.** After 24 to 48 hours, adjust the temperature control to the setting that best suits your needs. The setting of "4" should be appropriate for normal use.
- To turn the appliance off, turn the temperature control to "0."

### Electrical Connection

- Turning the temperature control to "0" position stops the cooling cycle but does not shut off the power of the unit.
- If the unit is unplugged, has lost power or is turned off, you must wait 3 to 5 minutes before restarting the unit. If you attempt to restart before this time delay, the unit will not start.

### Food Storage

- Wrap food in plastic wrap before storing. Place food evenly on wire rack.
- Let hot food cool down before putting into this refrigerator for saving energy.
- Don't open door frequently.
- Keep space between foods inside refrigerator.
- Keep food dry before storage.

### Installing Your Unit

- Remove food from refrigerator when power is out.
- Place your unit on a floor that is strong enough to support the unit when it is fully loaded.
- Locate the unit away from direct sunlight and sources of heat (stove, heater, radiator, etc). Direct sunlight may affect the acrylic coating and heat sources may increase electrical consumption. Extreme cold ambient temperatures may also cause the unit not to perform properly.
- Plug the unit into an exclusive, properly installed-grounded GFI wall outlet. Do not under any circumstances cut or remove the third (ground) prong from the power cord. Any questions concerning power and/or grounding should be directed toward a certified electrician.
- After plugging the appliance into a wall outlet, allow the unit to cool down for 2-3 hours before placing food into the refrigerator compartment.

## REVERSE REFRIGERATOR DOOR

---

### HARDWARE CONTENTS

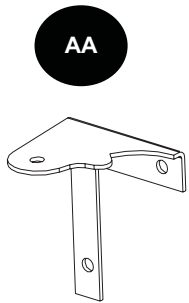

Hinge 3  
Qty. 1

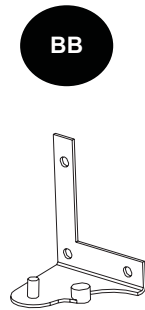

Hinge 4  
Qty. 1

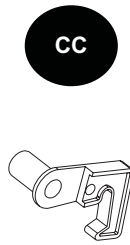

Plastic  
Stopper  
Qty. 1



Hinge Nut  
Qty. 1



ST4.2\*10  
Screw  
Qty. 1

### PREPARATION

The direction of the fridge door is reversible. Before reversing the door, make sure all parts are present. Compare parts with hardware contents list. If any part is missing or damaged, do not attempt to assemble the product.

Make sure remove all food from the fridge.

**!** **CAUTION:** Make sure the fridge is turn off (turn the temperature control inside the fridge to "OFF."), then unplug the power cord. Failure to unplug the unit could result in electrical shock or personal injury.

**Estimated Assembly Time: 30 minutes by two people**

**Tools Required for Assembly: Phillips Screwdriver**

## REVERSE REFRIGERATOR DOOR

1. Pull the drawers out. Press the drawer slide release levers. One side will push down, the other side pull push up. Then remove the drawers and set aside.

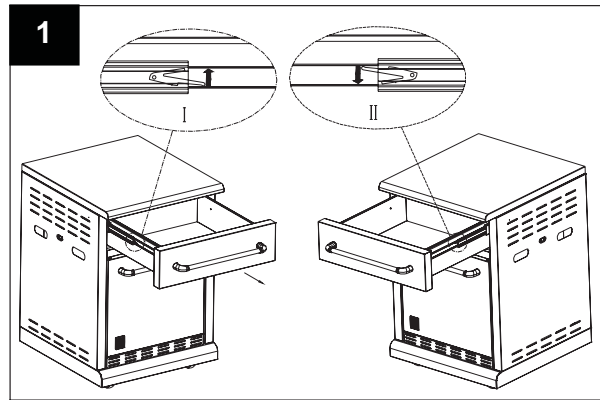

2. Remove the four M4\*8 screws securing fridge clamp panel to the left and right side panels. Take out the fridge clamp panel out.

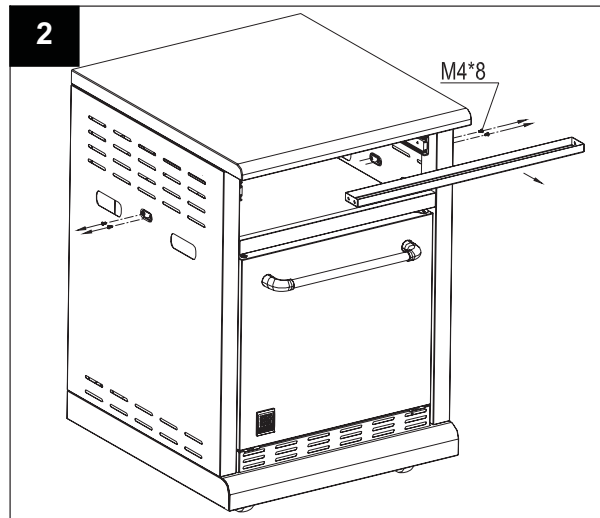

3. Remove the two M6\*12 screws on rear panel and two M6\*16 screws on base panel securing the fridge. Carefully take the fridge out.

Note: Make sure lift up the fridge to avoid scratching the base panel.

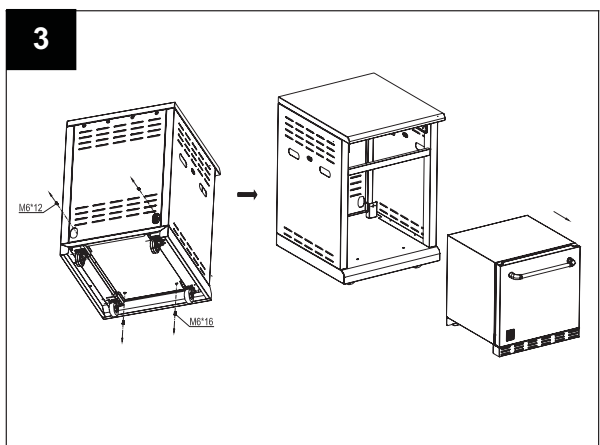

## REVERSE REFRIGERATOR DOOR

4. Unscrew the door spindle screw from top right corner of the fridge then carry down the fridge door.

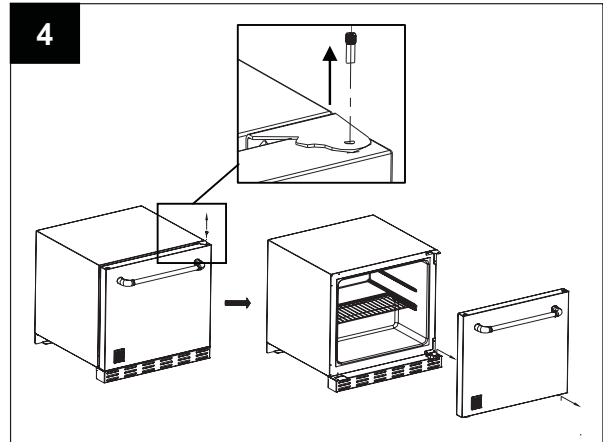

5. Remove the six M5\*10 screws securing the hinge 1 and the hinge 2 on the top right and bottom right corners. Set the hinges aside and reinstall the six screws. Remove the six M5\*10 screws on top left and bottom left corners. Secure hinge 3 (A) and hinge 4 (B) to the top left and bottom left corners with the six screws.

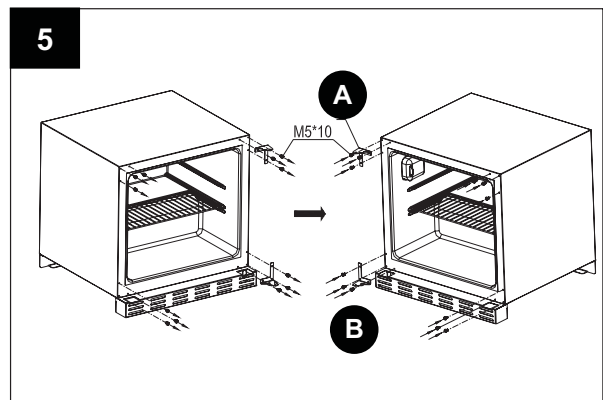

6. Use a screwdriver or any hard tools to clear out any material through the hole opening under the bottom left corner of the fridge door. This opening needs to be cleared in order to insert the plastic stopper (C) and secure it with screw (E). Install the door to fridge. Screw the hinge nut (D) to secure the fridge door.

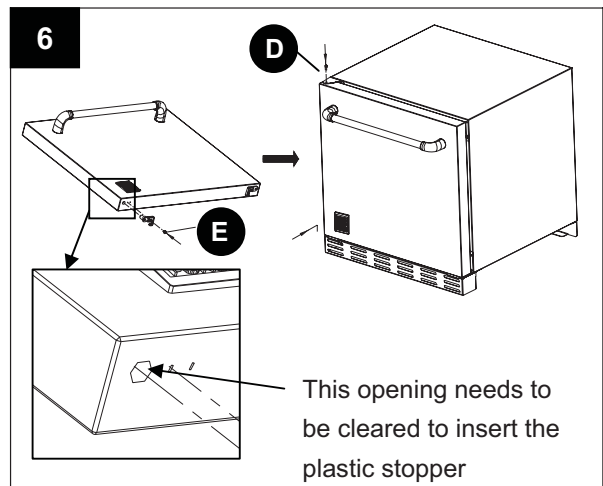

## REVERSE REFRIGERATOR DOOR

7. Reinstall the fridge and secure it to the unit with two M6\*12 screws through rear panel and two M6\*16 screws through base panel.

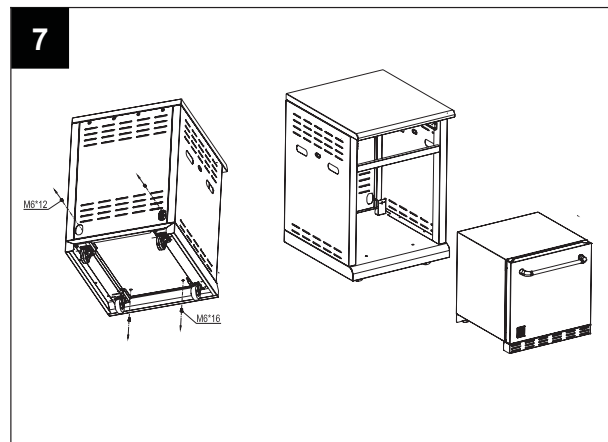

8. Reinstall the fridge clamp and secure it to the unit with four M4\*8 screws through the left and right side panels.

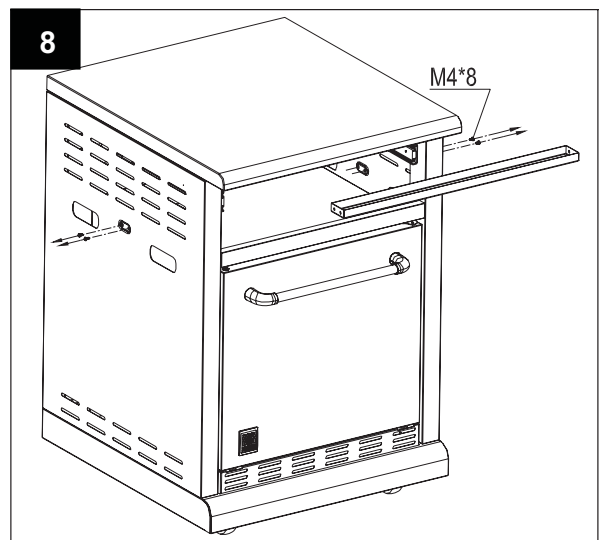

9. Reinstall the drawer to the unit.

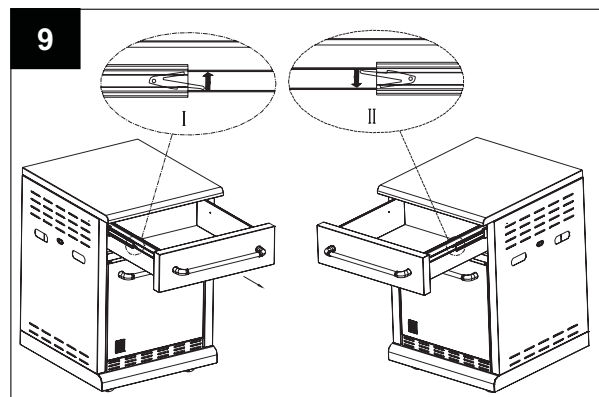



## CARE AND MAINTENANCE

---

### Cleaning Your Unit

- Turn the temperature control to "O," unplug the unit, and remove the food and shelf.
- Wash the inside surfaces with a warm water and baking soda solution. The solution should be about 2 tablespoons of baking soda to one quart of water.
- Wash the shelf and tray with a mild detergent solution.
- The outside of the unit should be cleaned with mild detergent and warm water.
- Wring excess water out of the sponge or cloth before cleaning the area of the controls or any electrical parts.
- Wash the outside cabinet with warm water and mild liquid detergent. Rinse well and wipe dry with a clean soft cloth.



#### CAUTION:

Do not use boiling water because it may damage the plastic parts. In addition, never use a sharp or metallic instrument to remove frost as it may damage the cooling system and will void the warranty. We recommend using a plastic scraper to remove any frost build-up.



#### CAUTION:

Failure to unplug the unit could result in electrical shock or personal injury.

### Installing Your Unit

Most power failures are corrected within a few hours and should not affect the temperature of your unit if you minimize the number of times the door is opened. If the power is going to be off for a longer period of time, you need to take the proper steps to protect your food.

### Vacation Time

- **Short vacation:** Leave the unit operating during vacations of less than three weeks.
- **Long vacation:** If the appliance will not be used for several months, remove all food and unplug the power cord. Clean and dry the interior thoroughly. To prevent odor and mold growth, leave the door open slightly, blocking it open if necessary.

### Moving Your Unit

- Remove all food.
- Securely tape down all loose items inside your unit.
- Tape the door shut.
- Be sure the unit stays secure in the upright position during transport. Also protect the outside of unit with a blanket or similar item.

## **CARE AND MAINTENANCE**

---

### **Energy Saving tips**

- Let hot foods cool to room temperature before placing in the unit. Overloading the unit forces the compressor to run longer.
- Be sure to wrap foods properly and wipe containers dry before placing them in the unit. This cuts down on frost build up inside the unit.
- Unit wire rack should not be lined with aluminum foil, wax paper or paper towels. Liners interfere with cold air circulation, making the unit less efficient.
- Organize and label food to reduce door openings and extended searches. Remove as many items as needed at one time and close the door as soon as possible.

### **GRANITE MAINTENANCE**

Outdoors can be very harsh on the granite of your refrigerator. There are things visible that can affect the granite like dirt and pollen and things not visible like UV Rays. Please follow these instructions to preserve the granite's natural beauty:

- Granite is a hard, non-porous natural stone and is relatively not affected by harsh chemicals however it is recommended to use a neutral cleaner or stone soap (available in hardware stores or from a stone dealer), or a mild dishwashing liquid and warm water.
- Use a soft, clean cloth to clean the granite. Rinse after washing with the soap solution and dry with a soft, clean cloth.
- Blot up spills immediately, before they penetrate the surface.
- Clean as often as needed to keep grime and dirt removed.
- Granite must be sealed to prevent or minimize staining and/or fading. Leaving granite unsealed may make it difficult to remove stains in the future. It is recommended to seal your granite outdoors every 4-6 months depending on climate conditions.

## TROUBLESHOOTING

Many solutions given here can make your entertaining experience safer and more enjoyable. You can also call customer service department at **1-800-963-0211**, 8 a.m. - 6 p.m., EST, Monday -Thursday, 8 a.m. - 5 p.m., EST, Friday.

PROBLEM	POSSIBLE CAUSE	CORRECTIVE ACTION
Unit does not operate.	<ol style="list-style-type: none"> <li>1. Not plugged in.</li> <li>2. The circuit breaker tripped or a blown fuse.</li> <li>3. The unit temperature control is set at "O" position.</li> </ol>	<ol style="list-style-type: none"> <li>1. Firmly plug the cord into a live outlet with proper voltage.</li> <li>2. Reset the circuit breaker or replace the fuse.</li> <li>3. Refer to the Setting the Temperature Control section on page 4.</li> </ol>
Turn on and off frequently.	<ol style="list-style-type: none"> <li>1. The ambient temperature is hotter than normal.</li> <li>2. A large amount of food has been added to the unit.</li> <li>3. The door is opened too often.</li> <li>4. The door is not closed completely.</li> <li>5. The temperature control is not set correctly.</li> <li>6. The door gasket does not seal properly.</li> </ol>	<ol style="list-style-type: none"> <li>1. The motor will run longer under warm conditions. At normal room temperatures, expect your motor to run about 40% to 80% of the time. Under warmer conditions, expect it to run even more often.</li> <li>2 &amp; 3. Try to get everything you need out of the refrigerator at once, keep food organized so it is easy to find and close the door as the food is removed.</li> <li>4. Push the door firmly shut.</li> <li>5. Refer to the Setting the Temperature Control section on page 4.</li> <li>6. Clean gaskets and the surface that they touch. Rub a thin paraffin wax on the gaskets after cleaning.</li> </ol>
Vibrations.	The unit is not resting solidly on the floor.	Check to assure that the unit is level.
The unit seems to make too much noise.	Troublesome noises from the refrigerator: clicking, scraping, squealing, thumping, dripping or running water.	<ol style="list-style-type: none"> <li>1. The dripping or running water noise may indicate that the defrost water drain is clogged. The clicking noise usually indicates a compressor shutting down due to overload, overheating, shorting out, or the relay start up system. The scraping noise is usually the condenser fan rubbing against the cardboard shroud. The squealing is usually a defective condenser fan motor.</li> </ol>

## TROUBLESHOOTING

---

<b>PROBLEM</b>	<b>POSSIBLE CAUSE</b>	<b>CORRECTIVE ACTION</b>
The door will not close properly.	<ol style="list-style-type: none"><li>1. The unit is not level.</li><li>2. The gasket is dirty or bent.</li><li>3. The food are out of position.</li></ol>	<ol style="list-style-type: none"><li>1. Check to assure that the unit is level.</li><li>2. Clean gaskets and the surface that they touch. Rub a thin paraffin wax on the gaskets after cleaning.</li><li>3. Check for anything blocking the door. Remove any food that may be preventing the door from closing.</li></ol>

# TECHNICAL DATA AND WIRING DIAGRAM

## Technical Data:

Model	RF20D-A
Rated Voltage (V)	AC110
Rated Frequency (Hz)	60
Rated Input Power (W)	80
Energy Consumption (Kw.h /24h)	0.70
Rated Current (A)	1.45
Phase	1
Design Pressure (High) (Psig)	218
Design Pressure (Low) (Psig)	88
Refrigerant	R134a
Refrigerant Charge (Pounds)	0.064

## Wiring Diagram:

### Electric Wiring Diagram

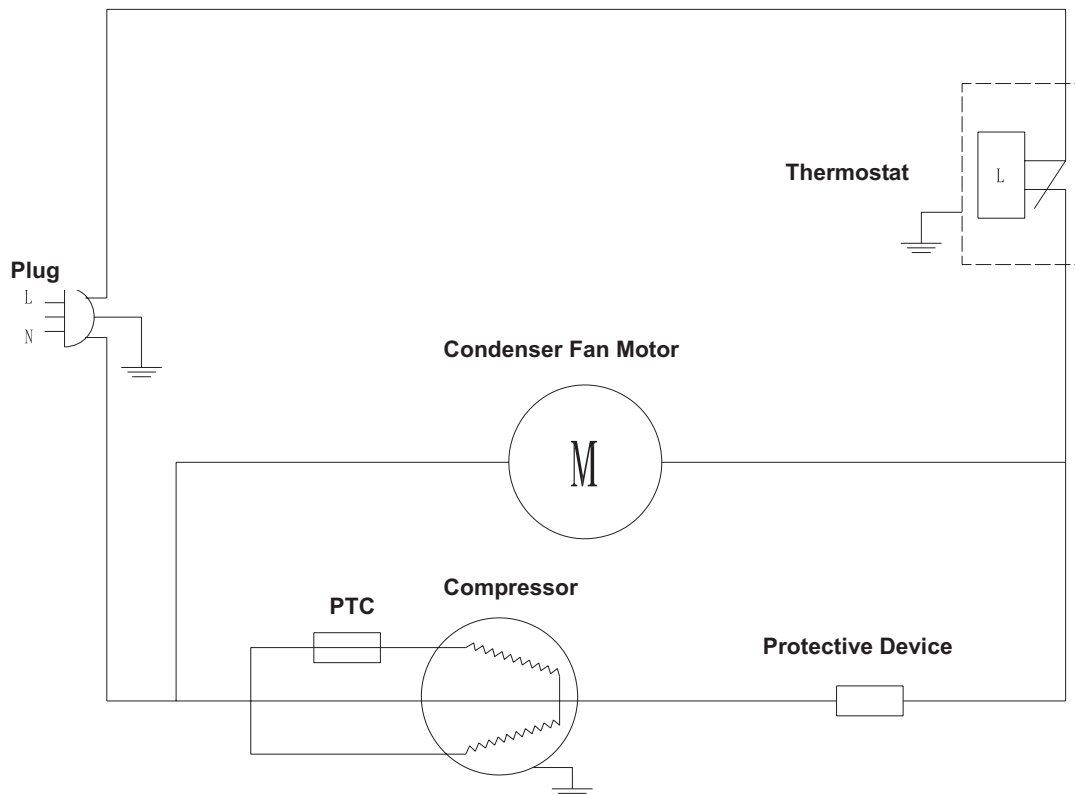

## **WARRANTY**

---

**Proof of purchase** is required to access this warranty program, which is in effect from the date of purchase. Customers will be subject to parts, shipping, and handling fees if unable to provide proof of the purchase or after the warranty has expired.

If you have any questions or problems, you can call our customer service department at **1-800-963-0211**, 8:00 a.m. to 6:00 p.m., EST, Monday - Thursday, 8:00 a.m. to 5:00 p.m., EST, Friday.

### **Limited Warranty**

**1- Year Warranty** on all parts affecting the operation of the product due to damage.

#### **Warranty Provisions:**

This warranty is non-transferable and does not cover failures due to misuse of improper installation or maintenance.

This warranty is for replacement of defective parts only. We are not responsible for incidental or consequential damages or labor costs.

This warranty does not cover corrosion or discoloration after the product is used, or lack of maintenance, hostile environment, accidents, alterations, abuse or neglect.

This warranty does not cover damage caused by heat, abrasive and chemical cleaners, or any damage to other components used in the installation or operation of the product.

Some states do not allow the limitation or exclusion of incidental or consequential damages, so the above limitations or exclusions may not apply to you. This warranty gives you specific legal rights, and you may also have other rights that vary from state to state.

## EXPLODED VIEW

For replacement parts, call our customer service department at **1-800-963-0211**, 8 a.m. – 6 p.m., EST, Monday - Thursday, 8 a.m. - 5 p.m., EST, Friday.

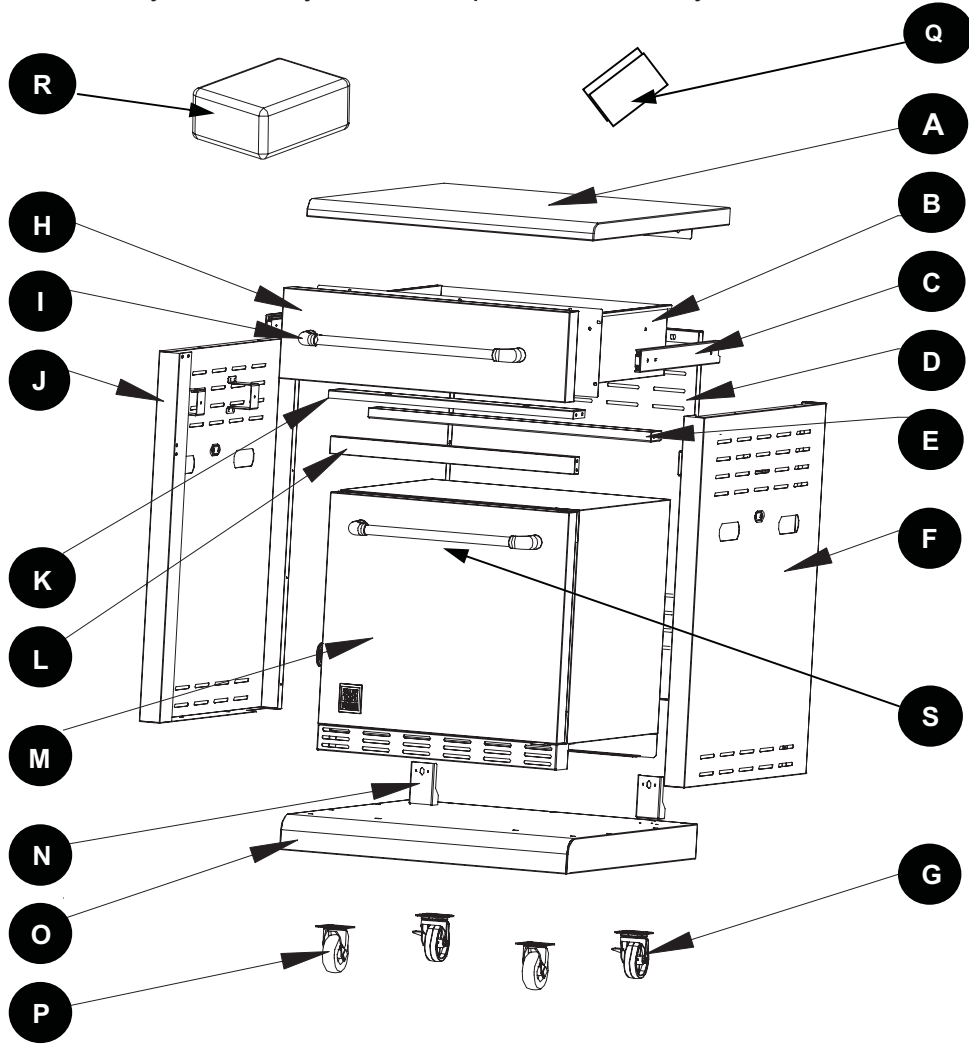

## REPLACEMENT PARTS LIST

PART	DESCRIPTION	QUANTITY	PART	DESCRIPTION	QUANTITY
A	Granite Countertop	1	K	Top Crossbeam	1
B	Drawer Base Panel	1	L	Bottom Crossbeam	1
C	Glide	2	M	Fridge	1
D	Rear panel	1	N	Fridge Rear Bracket	2
E	Fridge Clamp Panel	1	O	Base Panel Assembly	1
F	Right Side Panel Assembly	1	P	Castor	2
G	Locking Castor	2	Q	Door Reverse Kit	1
H	Cover	1	R	Product Cover	1
I	Door Handle Bracket	4	S	Fridge Handle	1
J	Left Side Panel Assembly	1			