

PORTFOLIO WALL LANTERN

Portfolio® is a registered trademark of LF, LLC. All rights reserved. ITEM #0616290

MODEL #IRZ1691LM-2

Français p. 7

Español p. 13

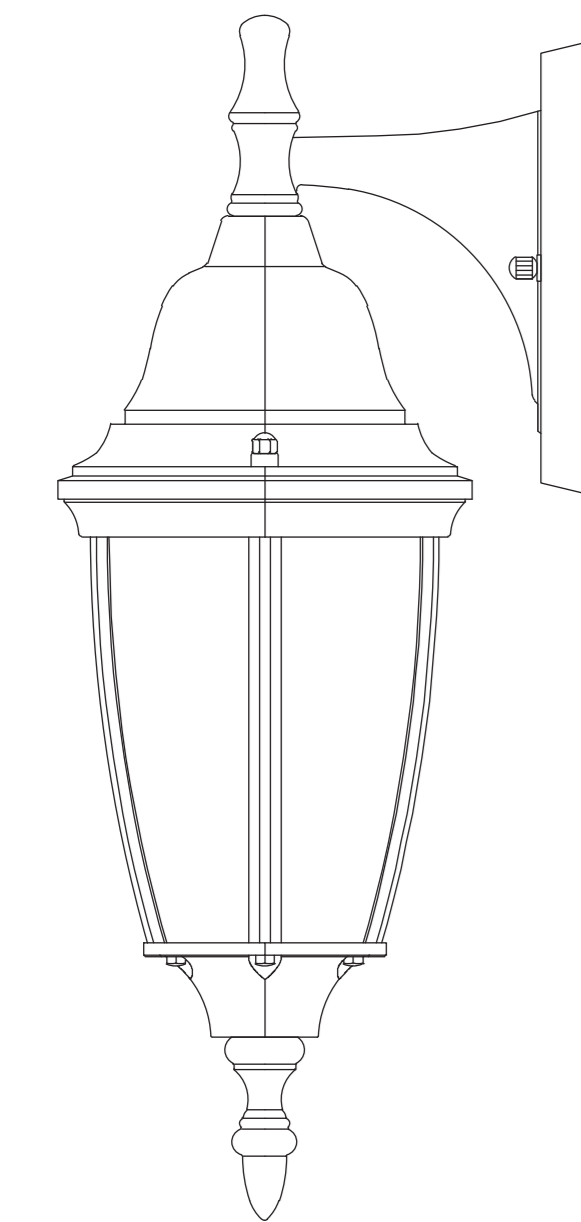

ATTACH YOUR RECEIPT HERE
Serial Number _____ Purchase Date _____

Questions, problems, missing parts? Before returning to your retailer, call our customer service department at 1-800-643-0067, 8 a.m. - 6 p.m., EST, Monday - Thursday, 8 a.m. - 5 p.m., EST, Friday.

PACKAGE CONTENTS

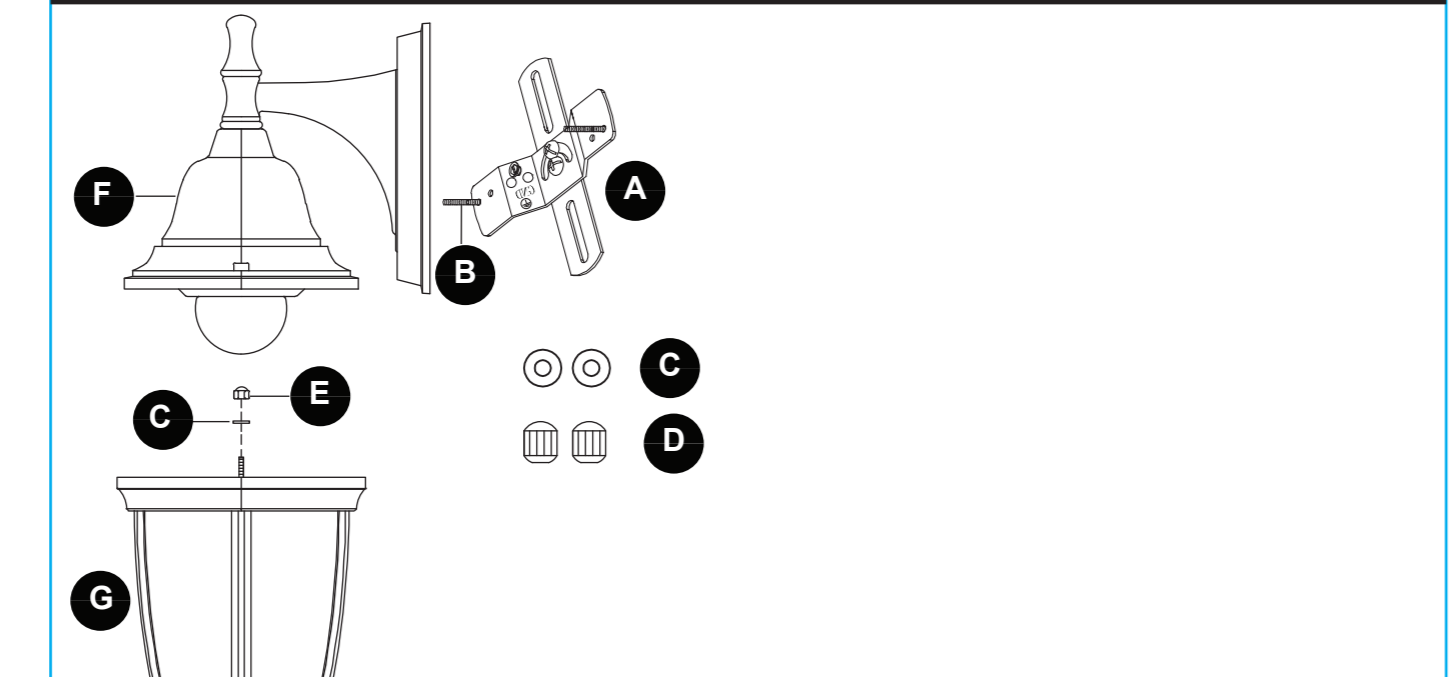

PART	DESCRIPTION	QUANTITY
A	Crossbar (preassembled to Fixture Body (F))	1
B	Mounting Screw (preassembled to Crossbar (A))	2
C	Washer (preassembled to Mounting Screw (B) and Shade (G))	4
D	Cap Nut (preassembled to Mounting Screw (B))	2
E	Secure Nut (preassembled to Shade (G))	2
F	Fixture Body	1
G	Shade	1
H	Nut (preassembled to Finial (I))	1
I	Finial	1

HARDWARE CONTENTS (shown actual size)

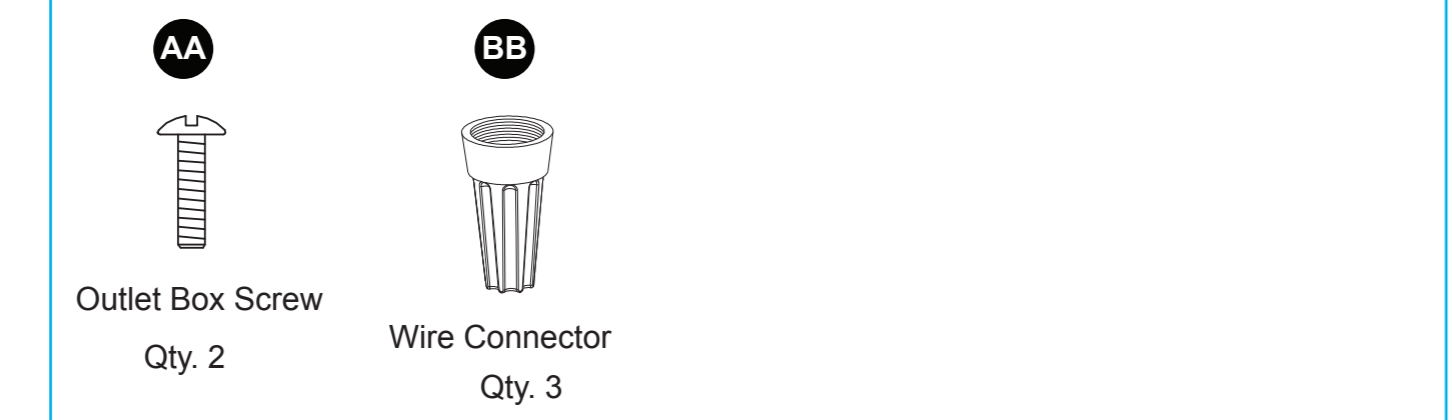

SAFETY INFORMATION

Please read and understand this entire manual before attempting to assemble, operate or install the product.

- WARNING**
- Some metal parts in the fixture may have sharp edges. To prevent cuts and scrapes, wear gloves when handling the parts.
 - Account for small parts and destroy packing material, as these may be hazardous to children
 - Use flashlight or alternate light source to light work area during installation.
 - Assistance may be required to support fixture during installation.

- CAUTION**
- DO NOT touch the LED model/parts at anytime as this may cause damage to the fixture.
 - Connect fixture to supply wires rated for at least 167 F.
 - Use only the supplied LED driver to power fixture.

Note: This equipment has been tested and found to comply with the limits for a Class B digital device, pursuant to Part 15 of the FCC Rules. These limits are designed to provide reasonable protection against harmful interference in a residential installation. This equipment generates, uses and can radiate radio frequency energy and, if not installed and used in accordance with the instructions, may cause harmful interference to radio communications. However, there is no guarantee that interference will not occur in a particular installation. If this equipment does cause harmful interference to radio or television reception, which can be determined by turning the equipment off and on, the user is encouraged to try to correct the interference by one or more of the following measures:

- Reorient or relocate the receiving antenna.
- Increase the separation between the equipment and receiver.
- Connect the equipment into an outlet on a circuit different from that to which the receiver is connected.
- Consult the dealer or an experienced radio/TV technician for help.

PREPARATION

Before beginning installation of product, make sure all parts are present. Compare parts with package contents list and hardware contents list. If any part is missing or damaged, do not attempt to assemble, install or operate the product.

Estimated Assembly Time: 15 - 20 minutes

Tools Required for Assembly (not included): Flathead screwdriver, Phillips screwdriver, Pliers, Wire cutters, Electrical tape, Safety goggles, Step ladder and Silicone caulking.

Helpful Tools (not included): Wire stripper, Level.

ASSEMBLY INSTRUCTIONS

- Turn off power at circuit breaker or fuse panel. Remove old fixture. Disconnect wiring.

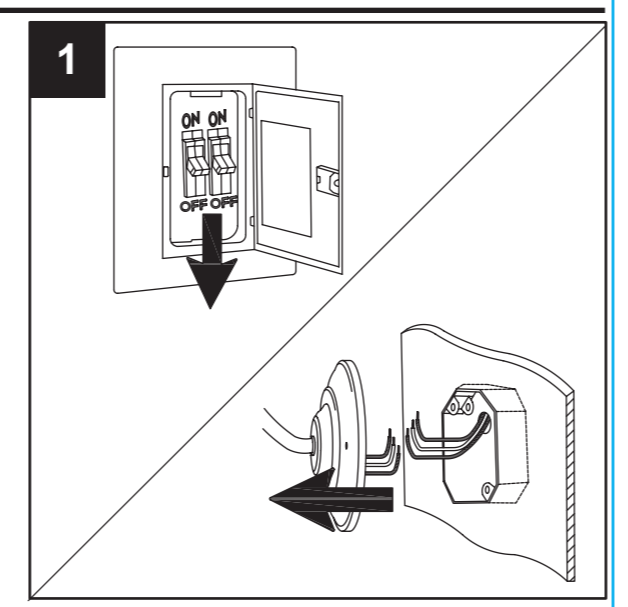

ASSEMBLY INSTRUCTIONS

- Unscrew the cap nuts (D) and remove washers (C) from mounting screws (B). Save for later use.

Separate the crossbar (A) from wall plate of fixture body (F). Then, attach the crossbar (A) to outlet box (not included) using outlet box screws (AA).
Note: The mounting screws (B) should protrude out from the outlet box.

Hardware Used

- AA Outlet Box Screw x 2

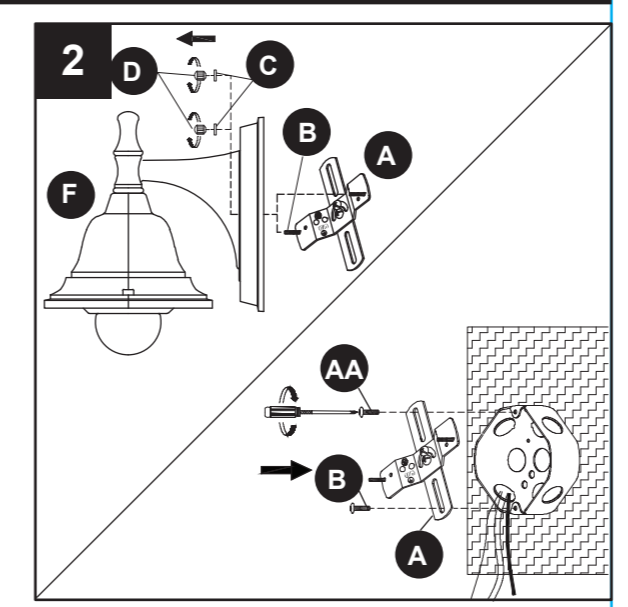

- Unscrew the nut (H) from finial (I). Then, attach finial (I) to shade (G), securing with nut (H).

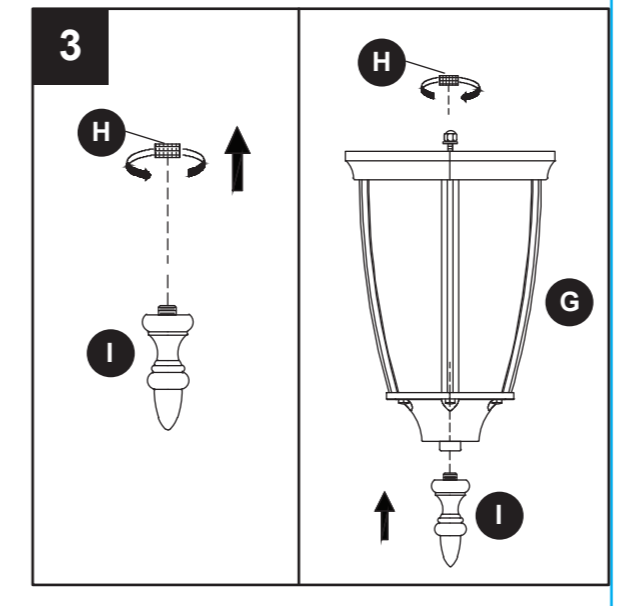

- Remove secure nuts (E) and washers (C) from the top of shade (G). Attach the shade (G) to fixture body (F), securing with washers (C) and secure nuts (E).

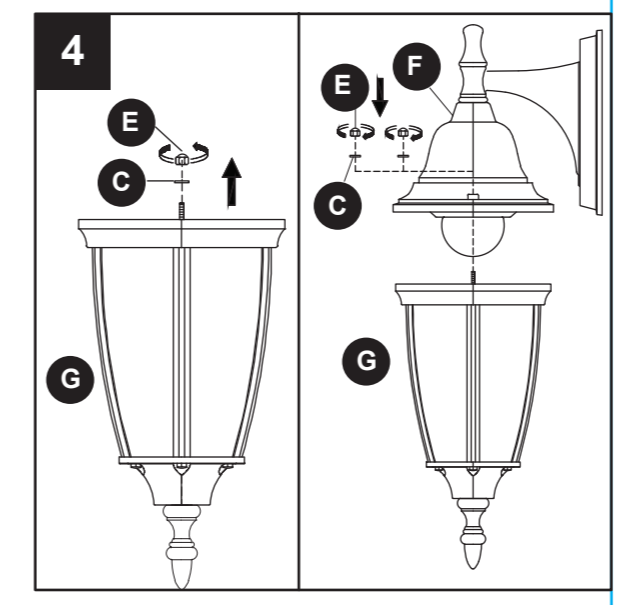

ASSEMBLY INSTRUCTIONS

- Strip 3/4 in. of insulation from fixture wire ends. Twist stripped ends together with pliers (not included), black to black (power), white to white (neutral). Snip ends. Wrap the ground wire from the outlet box around the green screw preassembled on the crossbar (A), and then connect the ground wire from the outlet box to the ground wire from the fixture.
Helpful hint: If the outlet box doesn't have a ground wire, you can attach the ground wire from the fixture directly to the green screw on the crossbar (A). Attach wire connectors (BB) to ends. Tape wire connectors (BB) and wires together with electrical tape (not included).

Hardware Used

- BB Wire Connector x 3

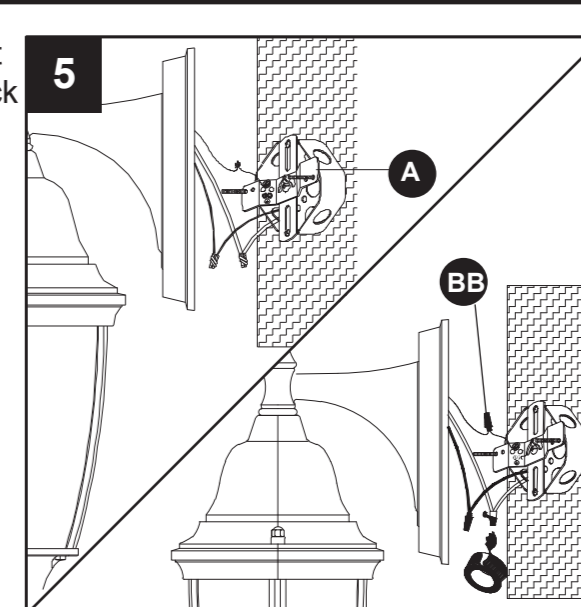

- Place fixture body (F) onto mounting screws (B). Secure with previously removed washers (C) and cap nuts (D).

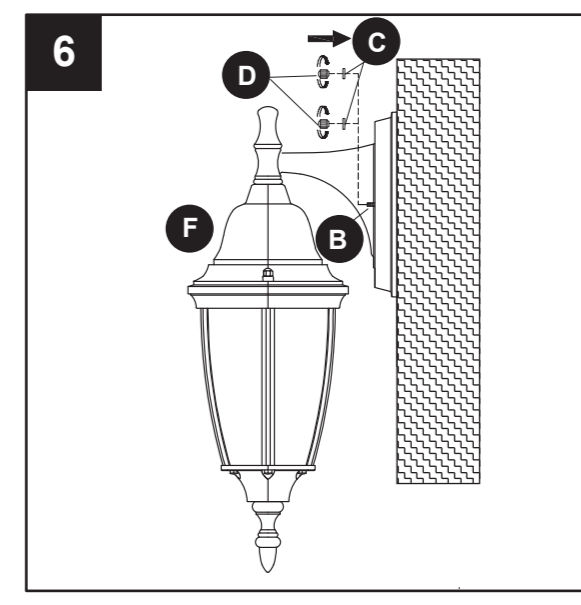

- Use silicone caulk (not included) to seal between wall plate and wall.
CAUTION: Leave bottom unsealed so moisture can drain out.

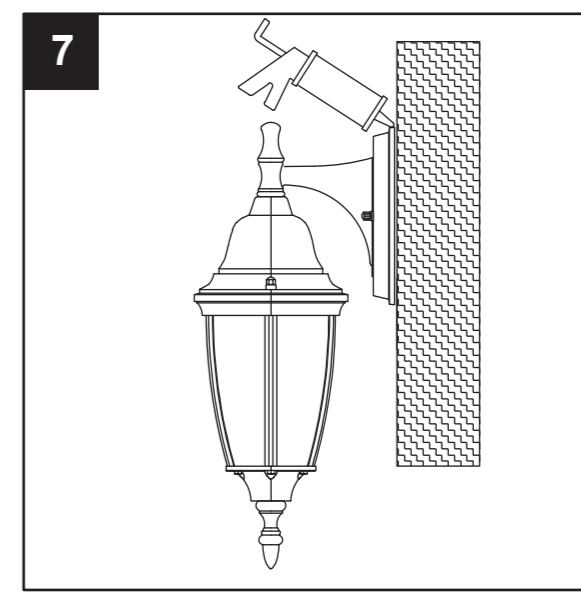

CARE AND MAINTENANCE

- Shut off main power before cleaning light with damp cloth or window cleaner. Do not use abrasive cleansers.
- Bulb Information: 12-watt integrated LED included; do not attempt to replace the LEDs.

TROUBLESHOOTING

PROBLEM	POSSIBLE CAUSE	CORRECTIVE ACTION
LED chips will not light.	1. Power is off. 2. Faulty wire connection. 3. Faulty switch.	1. Make sure power supply is on. 2. Check wiring. 3. Test or replace switch.
Fuse blows or circuit breaker trips when light is turned on.	Crossed wires or power wire is grounding out.	Check wire connections.

WARRANTY

The manufacturer warrants all of its lighting fixtures against defects in materials and workmanship for three (3) years limited from the date of purchase. If within this period the product is found to be defective in material or workmanship, the product must be returned, with a copy of the original sales receipt as proof of purchase, in the original carton, to the place of purchase. The manufacturer will, at its option, repair, replace or refund the original purchase price to the consumer. This warranty does not cover fixtures becoming defective due to misuse, accidental damage, improper handling and/or installation and specifically excludes liability for direct, incidental or consequential damages. As some states do not allow exclusions or limitations on an implied warranty, the above exclusions and limitations may not apply to you. This warranty gives you specific legal rights. You may have other rights that vary from state to state.

REPLACEMENT PARTS LIST

For replacement parts, call our customer service department at 1-800-643-0067, 8 a.m. - 6 p.m., EST, Monday - Thursday, 8 a.m. - 5 p.m., EST, Friday.

PART	DESCRIPTION	PART #
A	Crossbar	0616290-A
B	Mounting Screw	0616290-B
C	Washer	0616290-C
D	Cap Nut	0616290-D
E	Secure Nut	0616290-E
AA	Outlet Box Screw	0616290-AA
BB	Wire Connector	0616290-BB

