



ITEM #0208820, #0208807

DUSK-TO-DAWN LIGHT

MODEL #GU8013-BZ-I, GU8013-WH-I

Utilitech & UT Design® and Grounded in Quality® are registered trademarks of LF, LLC. All Rights Reserved.

Français p. 8

Español p. 15

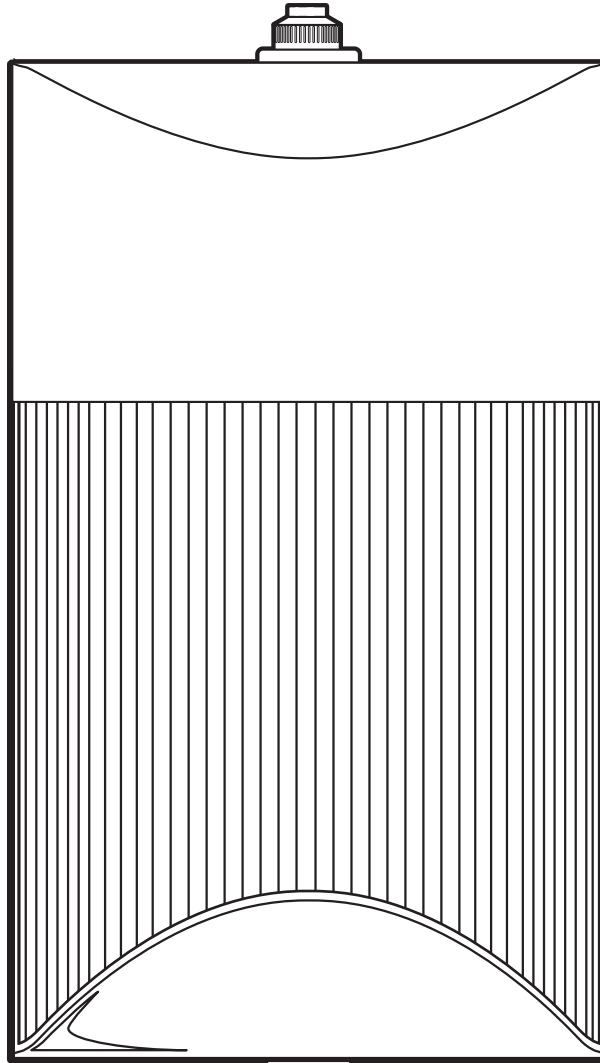

ATTACH YOUR RECEIPT HERE

Serial Number: _____ Purchase Date: _____



Questions, problems, missing parts? Contact the customer service department at 1-866-994-4148, 8 a.m. - 6 p.m., EST, Monday - Thursday, 8 a.m. - 5 p.m., EST, Friday.



PACKAGE CONTENTS

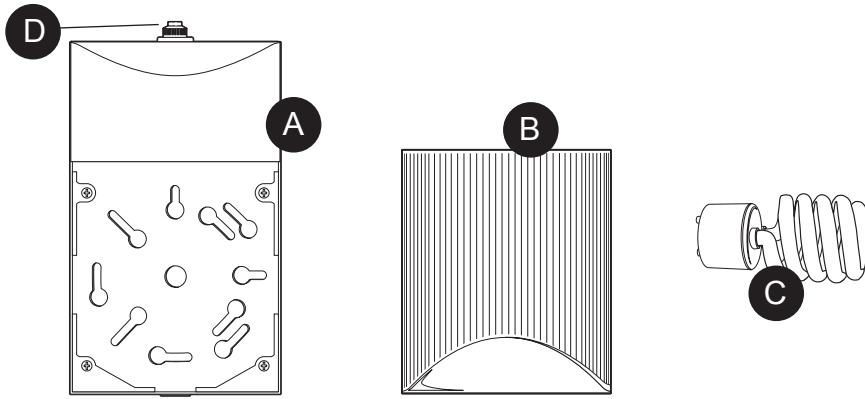

PART	DESCRIPTION	QUANTITY
A	Fixture	1
B	Diffuser	1

PART	DESCRIPTION	QUANTITY
C	Bulb	1
D	Dusk-to-Dawn Sensor	1

HARDWARE CONTENTS (shown actual size)

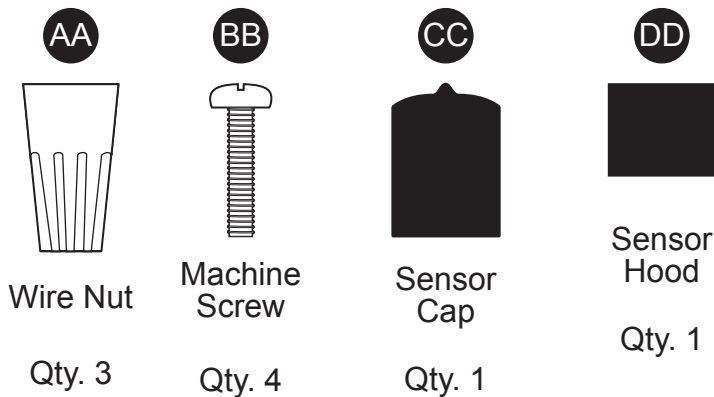

Wire Nut

Machine
Screw

Sensor
Cap

Sensor
Hood

Qty. 3

Qty. 4

Qty. 1

Qty. 1

SAFETY INFORMATION

WARNING

- Shut off power at the circuit breaker or fuse panel before removing the old fixture or installing the new one.

CAUTION

- **DO NOT USE THIS FIXTURE WITH A DIMMING CIRCUIT.** If you presently have dimmer controls, you will need to remove them, and replace them with regular electrical switches. If you have a three-way dimmer, you will have to replace it with a regular three-way switch. If you are unfamiliar with electrical installations, it is recommended you have a qualified electrician do your installation.



LAMP CONTAINS MERCURY



Manage in accordance with Spills, Disposal and Site Cleanup Requirements.
In case of breakage, follow clean-up procedures provided by contacts below.

www.epa.gov/cflcleanup
1-866-284-4010

PREPARATION

Before beginning assembly of product, make sure all parts are present. Compare parts with package contents list and diagram above. If any part is missing or damaged, do not attempt to assemble the product. Contact customer service for replacement parts.

Estimated Assembly Time: 45 minutes

Tools Required for Assembly (not included): Flathead Screwdriver, Safety Glasses, Electrical Tape Phillips head Screwdriver, Wire Cutters, Pliers, Wire Strippers, Step Ladder, Level.

ASSEMBLY INSTRUCTIONS

With power disconnected to your electrical box, remove the old fixture. If your old fixture is attached to an electrical box having more than two (2) wire leads, it is recommended you use tape and markings to keep track of which wires were attached to each other.

1. Screw the machine screws (BB) into the electrical box until there is about 3/8 in. between the wall and the underside of the machine screw (BB) head (Fig. 1).

Hardware Used

BB	Machine Screw		x 2
-----------	---------------	-----------------------------------------------------------------------------------	-----

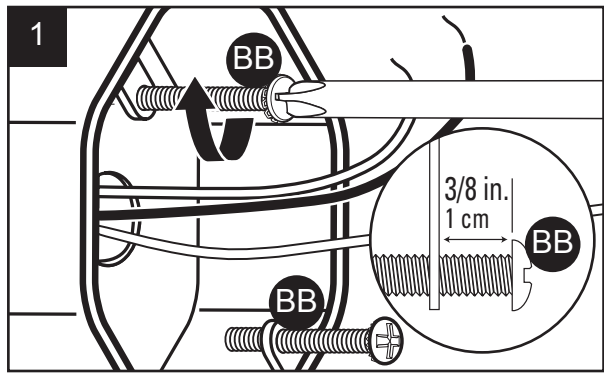

2. Remove the diffuser (B) from the fixture (A) by squeezing the tab on the bottom of the diffuser (B) while pulling the diffuser (B) up and out of the fixture (A) (Fig. 2).

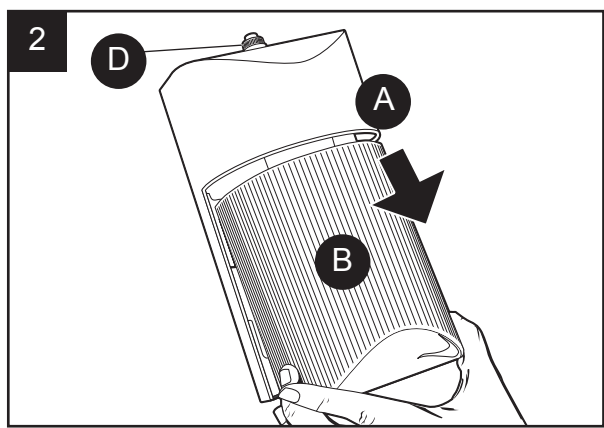

3. Once you have determined the position the fixture (A) will be mounted, mark the corresponding knock-outs and remove them (Fig. 3). CAREFULLY REMOVE THE KNOCK-OUT BY HAMMERING A FLATHEAD SCREWDRIVER OR PUNCH UNTIL THE SURFACE BREAKS. If the knock-out did not break free, use pliers and bend it back and forth until it snaps off.

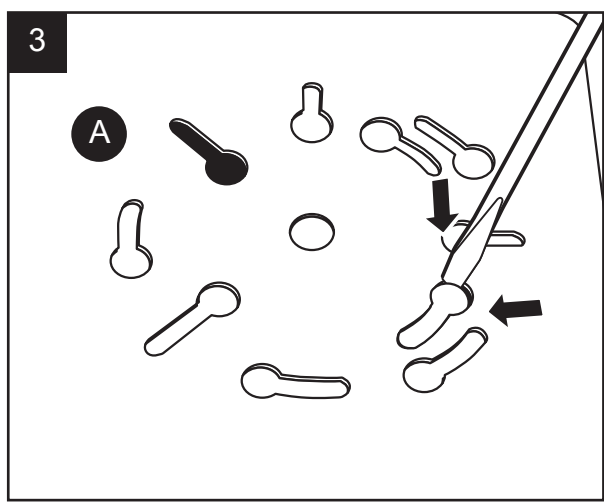

ASSEMBLY INSTRUCTIONS

4. For safety and proper operation, the fixture (A) must be properly grounded. If you are unfamiliar with the methods of properly grounding your fixture (A), consult a qualified electrician. A green or bare copper ground wire is pre-attached to your fixture (A). If the electrical box is plastic and has a green or bare copper grounding wire inside, the bare end of the fixture grounding wire must be secured to the green grounding wire inside the electrical box using one of the wire nuts (AA) (Fig. 4). If the electrical box is metal and contains no ground wire as part of a grounded electrical system, refer to STEP 6 for grounding instructions.

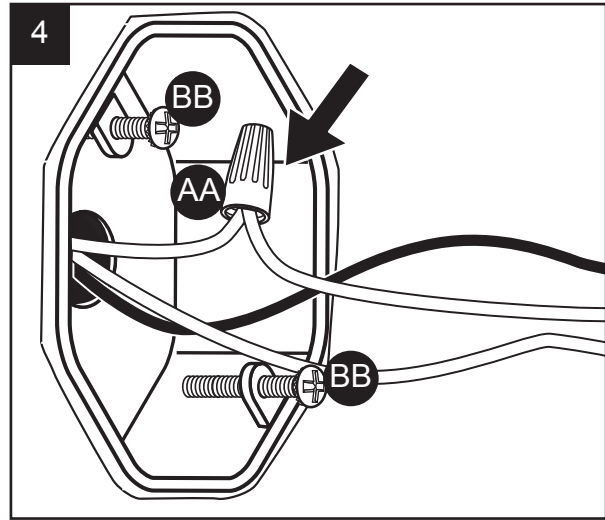

Hardware Used

AA Wire Nut x 1

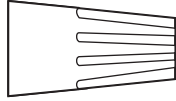

5. Connect the supply leads from the electrical box to the fixture wire leads using the wire nuts (AA) supplied in your installation hardware kit as per the illustration. The **black lead** from the fixture goes to the **black supply lead** and the **white lead** from the fixture goes to the **white supply lead** (Fig. 5). Secure the wire nuts properly to prevent the wires from coming loose. Tape the wire nuts to the wire using electrical tape. Carefully push the excess wires back inside the electrical box.

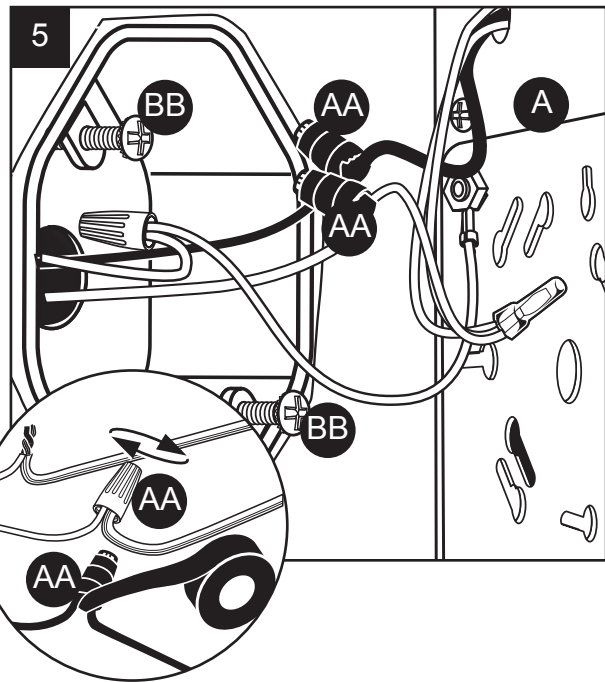

Hardware Used

AA Wire Nut x 2

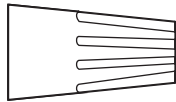

6. Position the fixture pan (A) over the electrical box and line them up the slots in the fixture pan with the slots in the electrical box. Hold in place and tighten the machine screws (BB) very tightly. The hardware kit includes two (2) screws (BB) specifically designed to ground the fixture (A) to a metal electrical box. Tighten the screws (BB) until the underside of the screwhead is cutting through the paint on the fixture's (A) surface and the pan is tight up against the mounting surface (Fig. 6). The underside of the screwhead is designed with a serrated edge or is affixed with one that when tightened against a painted surface will cut through to make contact with the metal underneath. In order for a ground to be made, the screws (BB) must be tightened to make a bare metal to bare metal contact.

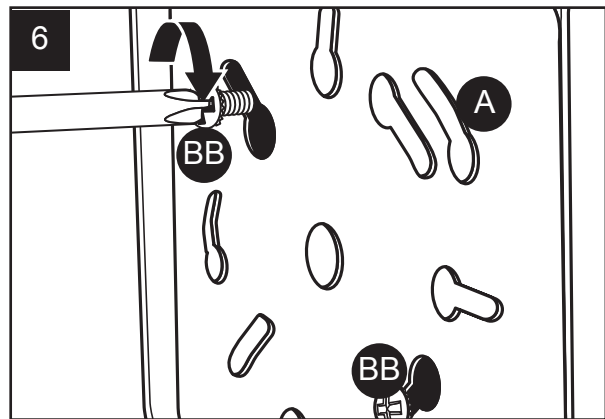

Hardware Used

BB Machine Screw x 2



ASSEMBLY INSTRUCTIONS

7. In the event of outdoor installation, you will need to use silicon or other waterproof caulk around the outer perimeter of the fixture (A) pan to prevent water seeping into the wiring compartment (Fig. 7).

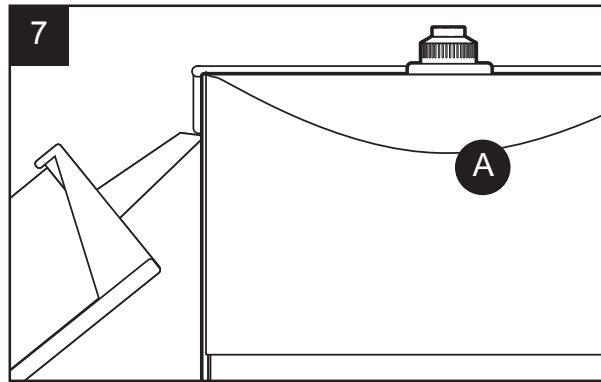

8. Insert the proper GU24 base 13W compact fluorescent bulb (C) into the socket (Fig. 8). Hold the bulb (C) by its base, insert the pins into the 2 curved slots in the bulb socket and twist clockwise until the bulb (C) "seats". The bulb can only go into the socket one way. Do NOT force the bulb (C). CAUTION: DO NOT HOLD THE BULB (C) BY THE GLASS DURING INSERTION OR REMOVAL TO PREVENT ACCIDENTAL BREAKAGE! HOLD THE BULB (B) BY THE PLASTIC BASE.

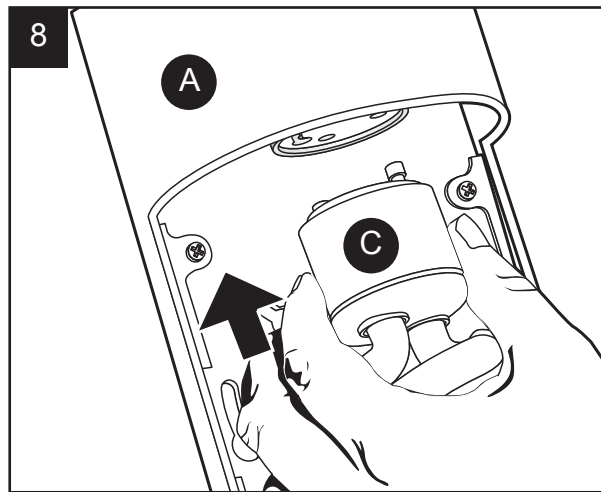

9. Slide the diffuser (B) into the fixture (A) and push on the tab at the bottom of the diffuser (B) so the diffuser (B) locks into place (Fig. 9). Restore power to the electrical box to make sure your fixture (A) is working properly.

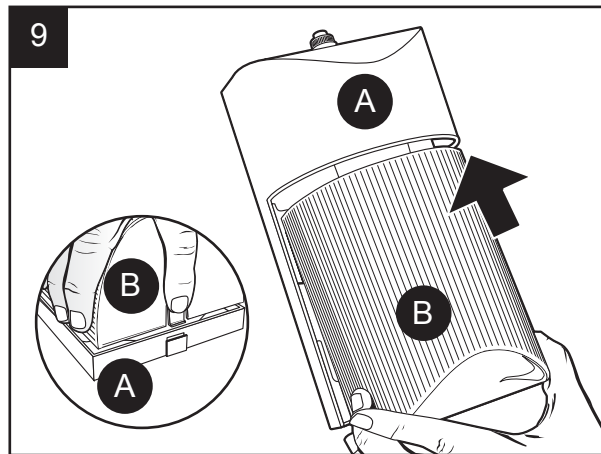

OPERATING INSTRUCTIONS

Your indoor/outdoor lantern is controlled by a dusk-to-dawn photo light sensor (E). Therefore, for your lantern to work properly, the electrical switch to the lantern MUST be turned ON at ALL times.

1. If your security light cycles ON and OFF, the dusk-to-dawn sensor (D) may be activating due to reflected light from a nearby surface. Place the sensor hood (DD) firmly over the dusk-to-dawn sensor (Fig. 1). This should prevent extraneous light from 'tripping' the dusk-to-dawn sensor (D).

Hardware Used

-  Sensor Hood  x 1

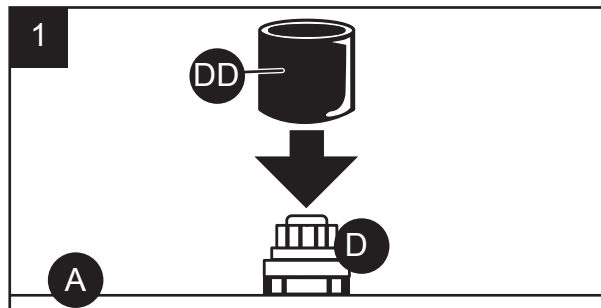

OPERATING INSTRUCTIONS

2. To disable the dusk-to-dawn sensor (D), you will need to install the sensor cap (CC) over the dusk-to-dawn sensor (D) (Fig. 2). This will prevent the dusk-to-dawn sensor (D) from controlling the ON/OFF function, and should allow you to control the fixture (A) with the wall switch.

Hardware Used

 Sensor Cap x 1

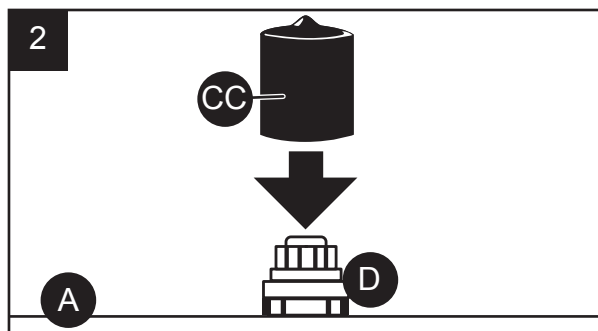

BULB REPLACEMENT INSTRUCTIONS

Your bulb should last up to 10,000 hours in normal use. When bulb replacement is necessary, you must replace the bulb with a CFL13W self-ballasted GU24 base fluorescent bulb. These bulbs are readily available at your local home center and most larger hardware stores.

Before replacing bulb (C), shut off power to the fixture at the circuit breaker or fuse panel. Allow sufficient time for fixture and lamp to cool.

1. Remove the diffuser (B) from the fixture (A) by squeezing the sides of the diffuser (B) while pulling the diffuser (B) up and out of the fixture (A).
2. Remove the defective bulb by grasping it by the plastic base and unscrewing it from the bulb socket 1/4 turn in counterclockwise direction.
3. Install the new bulb in the same manner you removed the old bulb (Fig. 1). Slide the diffuser (B) into the fixture (A) and push on the tab at the bottom of the diffuser (B) so the diffuser (B) locks into place. Restore power to the fixture.

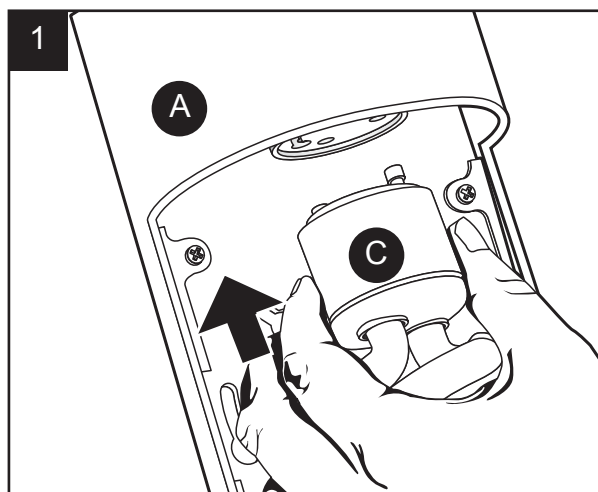

4. Dispose of the old lamp(s) in accordance with local, state, and/or federal laws, or go to www.lamprecycle.org for more information.

CARE AND MAINTENANCE

You may want to periodically clean the fixture using a mild, non-abrasive glass cleaner and soft cloth. Do NOT use solvents or cleaners containing abrasive agents. When cleaning the fixture, make sure you have the power turned off and do not spray liquid cleaner directly onto the bulb, socket, ballast, or wiring.

TROUBLESHOOTING

Minor problems often can be fixed without the help of an electrician. Before doing any work on the fixture, shut off power supply at the circuit breaker panel to avoid electrical shock.

PROBLEM	POSSIBLE CAUSE	CORRECTIVE ACTION
Fixture doesn't light.	<ol style="list-style-type: none"> 1. Power is off. 2. Bad wire connection. 3. Defective bulb(s). 4. Defective wall switch. 5. Photo sensor is inactive. 	<ol style="list-style-type: none"> 1. Check circuit breaker or wall switch. 2. Check wire splices. 3. Replace bulb(s). 4. Replace switch. 5. Cap sensor or wait until dark.
Circuit breaker trips when light is turned on.	<ol style="list-style-type: none"> 1. Crossed wires or power wire is grounded out. 	<ol style="list-style-type: none"> 1. Check wiring connections.

WARRANTY

The manufacturer warrants this lighting fixture to be free from defects in materials and workmanship for a period of (3) years from the date of original purchase by the consumer. We will repair or replace (at our option) the unit in the original color and style if available, or in a similar color and style if the original item has been discontinued, without charge. The manufacturer warrants the lamp for 3 years, providing the lamp is not used in a commercial application where it is on 24 hours per day, but is used in a residential environment for 3 - 5 hours per day. Defective units must be properly packed and returned to the manufacturer with a letter of explanation and your original purchase receipt showing date of purchase.

Call 1-866-994-4148 to obtain a return authorization number and an address where to ship your defective product. Note: No C.O.D. shipments will be accepted. The liability of the manufacturer is in any case limited to replacement of the defective light fixture product. The manufacturer will not be liable for any other loss, damage, or injury which is caused by the product. This limitation upon the liability of the manufacturer includes any loss, damage, or injury which is (I) to person or property or otherwise; (II) incidental or consequential in nature; (III) based upon theories of warranty, contract, negligence, strict liability, tort, or otherwise; or (IV) directly, or indirectly related to the sale, use, or repair of the product. This warranty gives you specific rights, and you may also have other rights which vary from state to state.

REPLACEMENT PARTS LIST

For replacement parts, call our customer service department at 1-866-994-4148, 8 a.m. - 6 p.m., EST, Monday - Thursday, 8 a.m. - 5 p.m., EST, Friday.

PART	DESCRIPTION	PART #
AA	Wire Nut	HDW8013-8313
BB	Machine Screw	HDW8013-8313
CC	Sensor Cap	HDW8013-8313
DD	Sensor Hood	HDW8013-8313

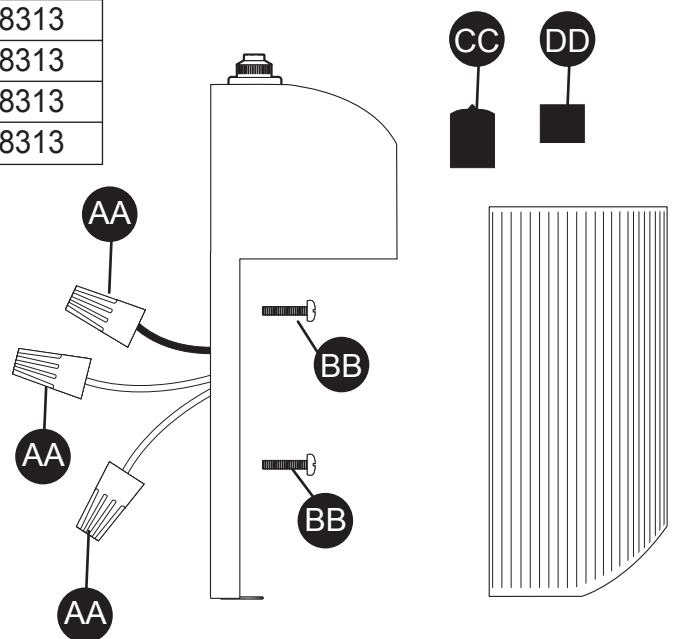

Printed in China

Utilitech & UT Design® and Grounded in Quality® are registered trademarks of LF, LLC. All Rights Reserved.