



ITEM #0339207, #0339208, #0339209, #0339210

PREMIUM WOOD TOWER

MODEL #WSWS-WU1C, #WSWS-WU1W
#WSWS-WU1P, #WSWS-WU1S

Français p. 16

Español p. 31

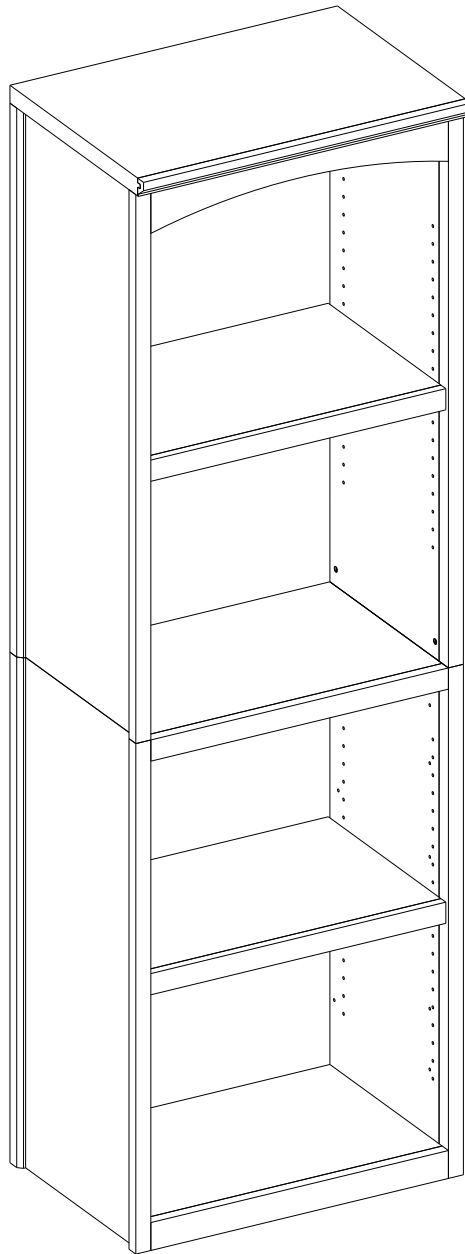

ATTACH YOUR RECEIPT HERE

Serial Number _____

Purchase Date _____



Questions, problems, missing parts? Before returning to your retailer, call our customer service department at 1-866-439-9800, 8 a.m. - 8 p.m., EST, Monday - Friday.

TABLE OF CONTENTS

Cam Lock System Operation.....	2
Package Contents.....	3
Hardware Contents	4
Safety Information	5
Preparation.....	5
Assembly Instructions	6
Care and Maintenance	13
Troubleshooting	13
Warranty	14
Replacement Parts List	14

CAM LOCK SYSTEM OPERATION

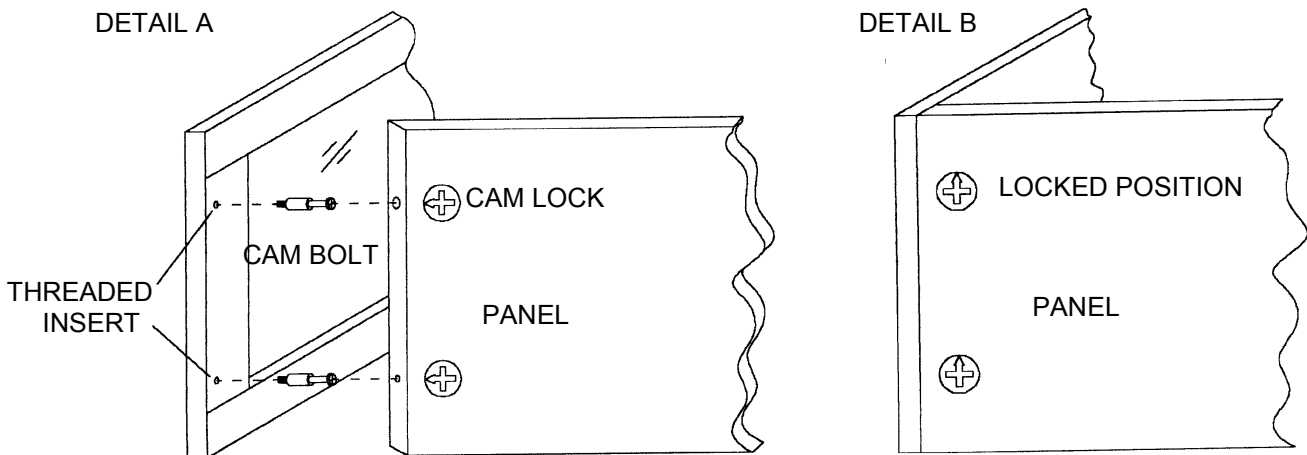

1. Screw cam bolt into the predrilled small holes on panel.
2. Insert cam lock into predrilled large hole on panel.
3. Make sure the arrow on the cam lock is pointed toward the cam bolt.
4. Connect both panels together, making sure cam bolt goes into predrilled hole on the end of panel with cam lock.
5. Once cam bolt is connected inside cam lock, take Phillips screwdriver and tighten cam lock clockwise.

PACKAGE CONTENTS

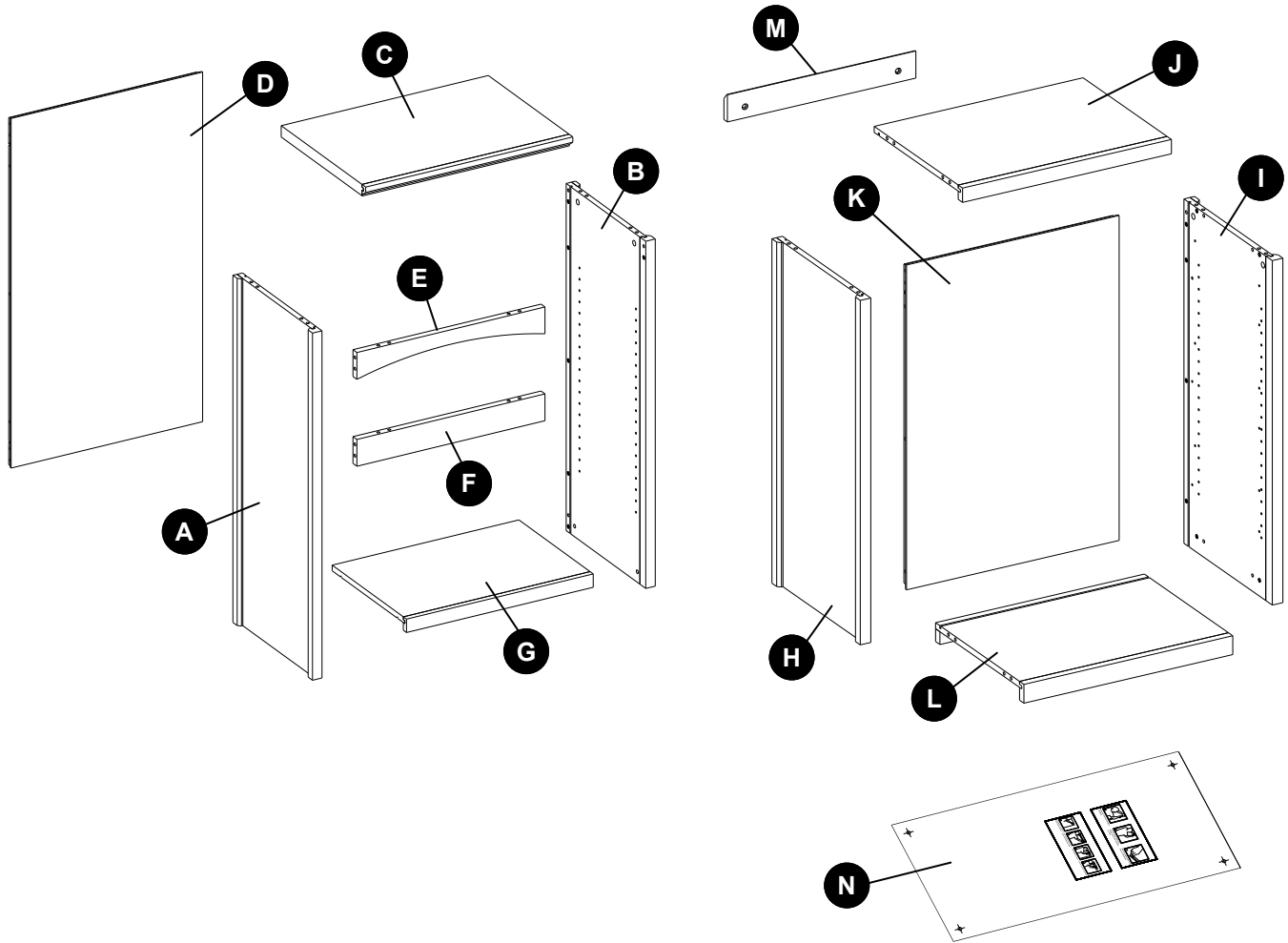

PART	DESCRIPTION	QUANTITY
A	Hutch Panel Left	1
B	Hutch Panel Right	1
C	Hutch Panel Top	1
D	Hutch Panel Back	1
E	Front Curved Stretcher	1
F	Front Straight Stretcher	1
G	Adjustable Shelf	2

PART	DESCRIPTION	QUANTITY
H	Base Panel Left	1
I	Base Panel Right	1
J	Base Panel Top	1
K	Base Panel Back	1
L	Base Panel Bottom	1
M	Wall Hanging Cleat	2
N	Installation Template	1

HARDWARE CONTENTS

AA

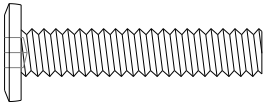

1/4 x 1-1/4 in.
Bolt

Qty. 12

BB



Lock
Washer

Qty. 12

CC

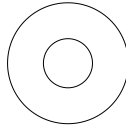

Flat
Washer

Qty. 12

DD

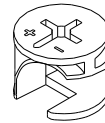

Large
Cam Lock

Qty. 34

EE

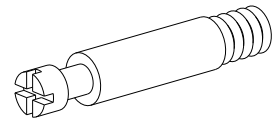

Medium
Cam Bolt

Qty. 30

FF

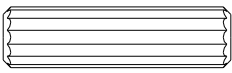

Large
Wood Dowel

Qty. 34

GG

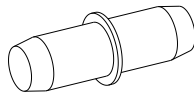

Shelf Pin

Qty. 8

HH

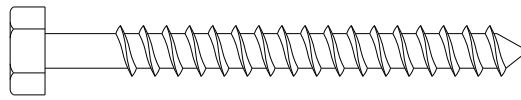

M8 x 2-1/2 in.
Lag Bolt

Qty. 4

II

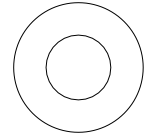

Large Flat
Washer

Qty. 4

JJ

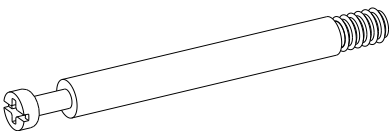

Large
Cam Bolt

Qty. 4

KK

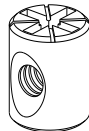

Barrel
Nut

Qty. 4

LL

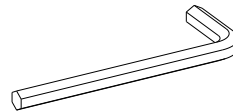

M4 Allen
Wrench

Qty. 1

MM

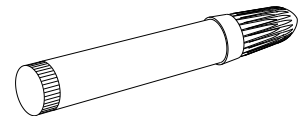

Touch-up Pen

Qty. 1
(not included for
Item #0339209)



SAFETY INFORMATION

Please read and understand this entire manual prior to assembling the product.

1. Do not allow children to climb or play in or around this product.
2. Use this unit for its intended purpose only. Do not use shelves as step ladder.
3. To avoid damage, assemble the product on a sturdy, level and protective surface.
4. Two or more persons must work together to install the unit onto the wall.
5. Make sure all bolts/screws are tightly fastened before the unit is used.
6. Check bolts/screws periodically and tighten them if necessary.

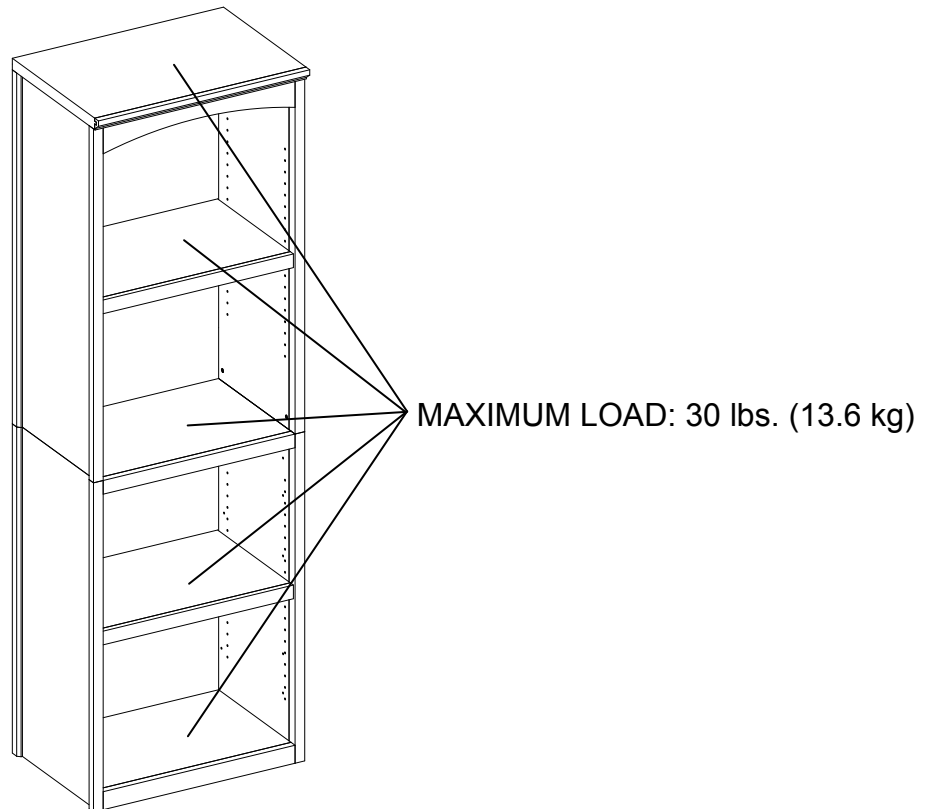

WARNING

THIS UNIT IS INTENDED FOR USE ONLY WITH THE MAXIMUM WEIGHTS INDICATED. USE WITH PRODUCTS HEAVIER THAN THE MAXIMUM WEIGHTS INDICATED MAY RESULT IN INSTABILITY CAUSING POSSIBLE INJURY. DISTRIBUTE WEIGHT EVENLY.

PREPARATION

Before beginning assembly of this product, make sure all parts are present. Compare parts with package contents list and hardware contents above. If any part is missing or damaged, do not attempt to assemble the product. Contact customer service for replacement parts.

Estimated Assembly Time: 60 minutes

Tools Required for Assembly (not included): Phillips Screwdriver, Level, Power Drill, 3/16 in. Drill Bit, 3/8 in. Drill Bit, 1/2 in. Socket Wrench, Stud Finder, Marking Pencil, Tape Measure, Step Ladder, and Hammer.

ASSEMBLY INSTRUCTIONS

Step 1 Base assembly

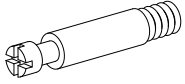
- EE** Medium Cam Bolt
 x 12

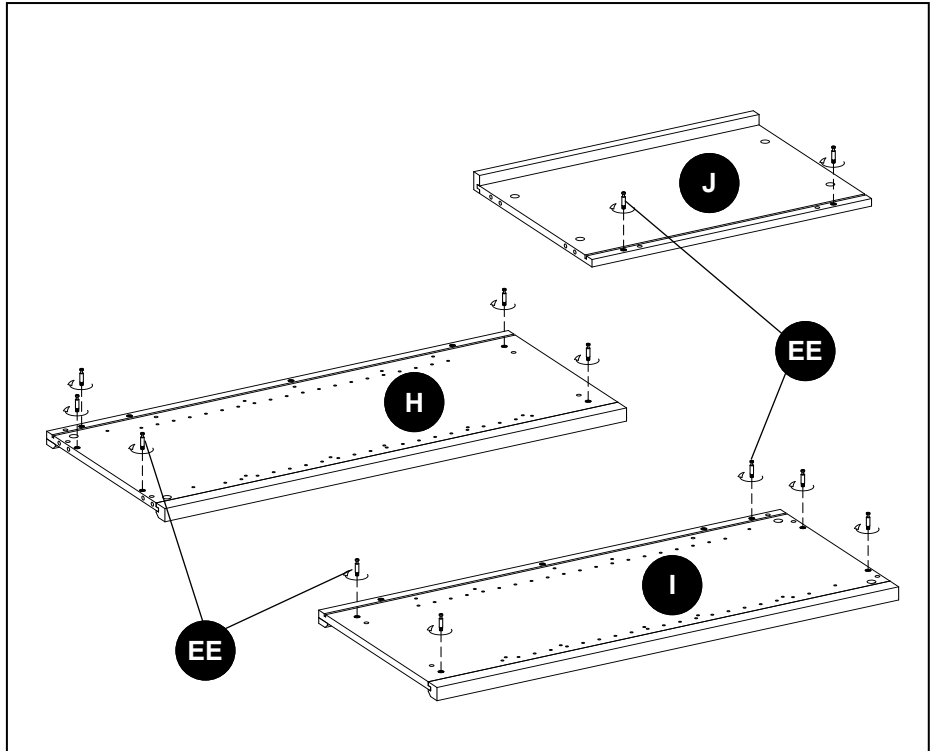

Step 2 Base assembly

- DD** Large Cam Lock
 x 2

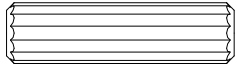
- FF** Large Wood Dowel
 x 2

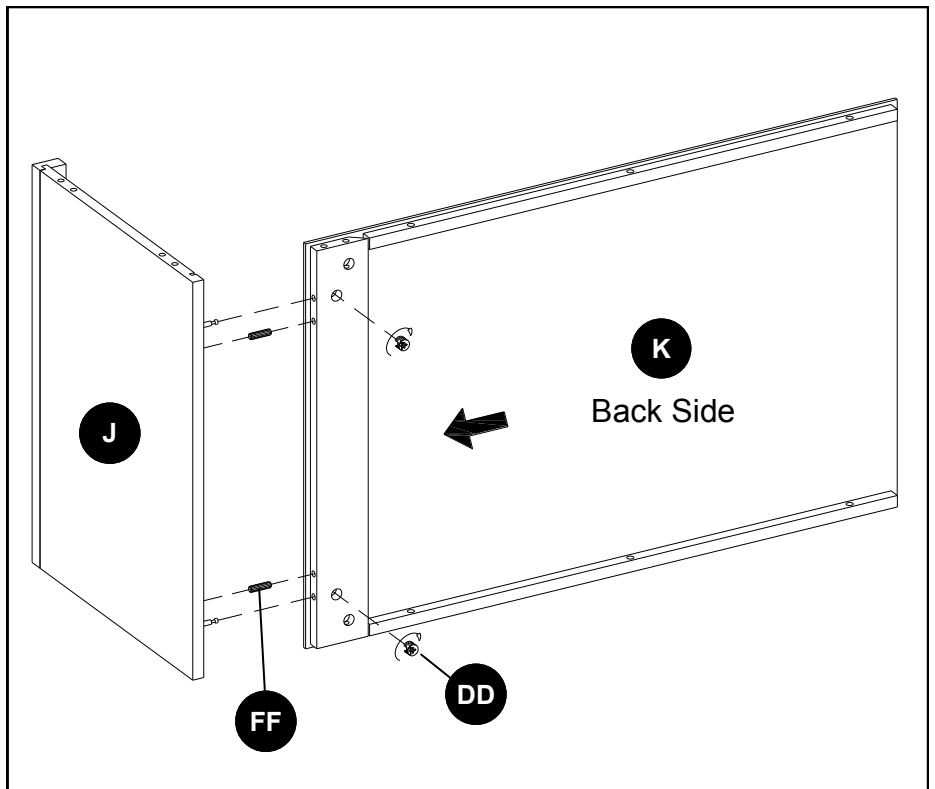

ASSEMBLY INSTRUCTIONS

Step 3 Base assembly

DD Large Cam Lock

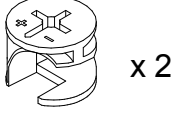

FF Large Wood Dowel

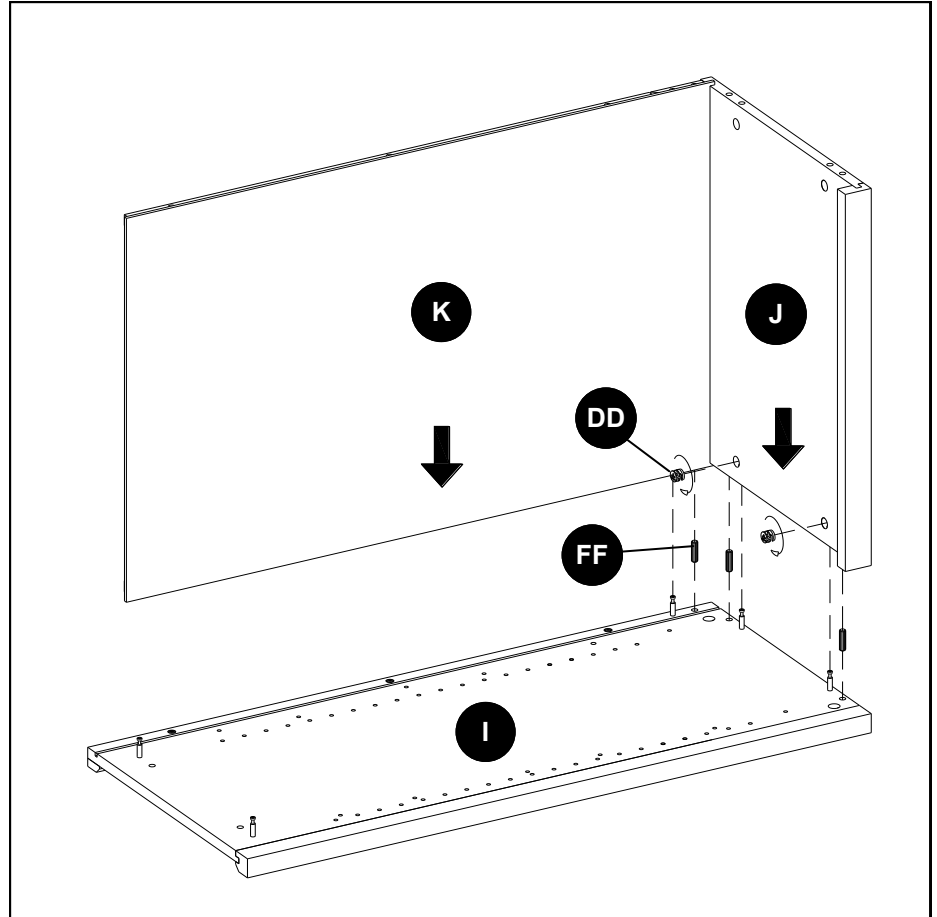

Step 4 Base assembly

AA 1/4 x 1-1/4 in. Bolt

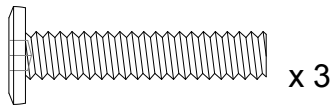

BB Lock Washer



CC Flat Washer

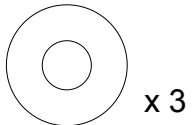

DD Large Cam Lock

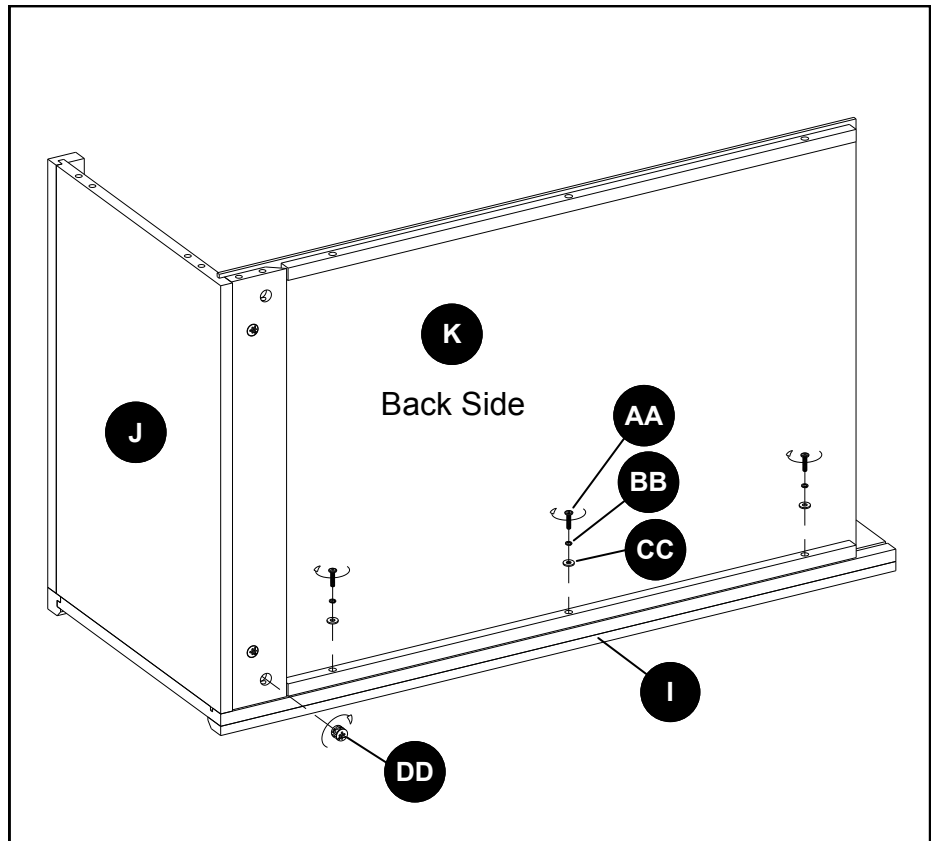
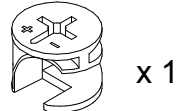

ASSEMBLY INSTRUCTIONS

Step 5

Base assembly

DD Large Cam Lock

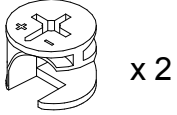

FF Large Wood Dowel

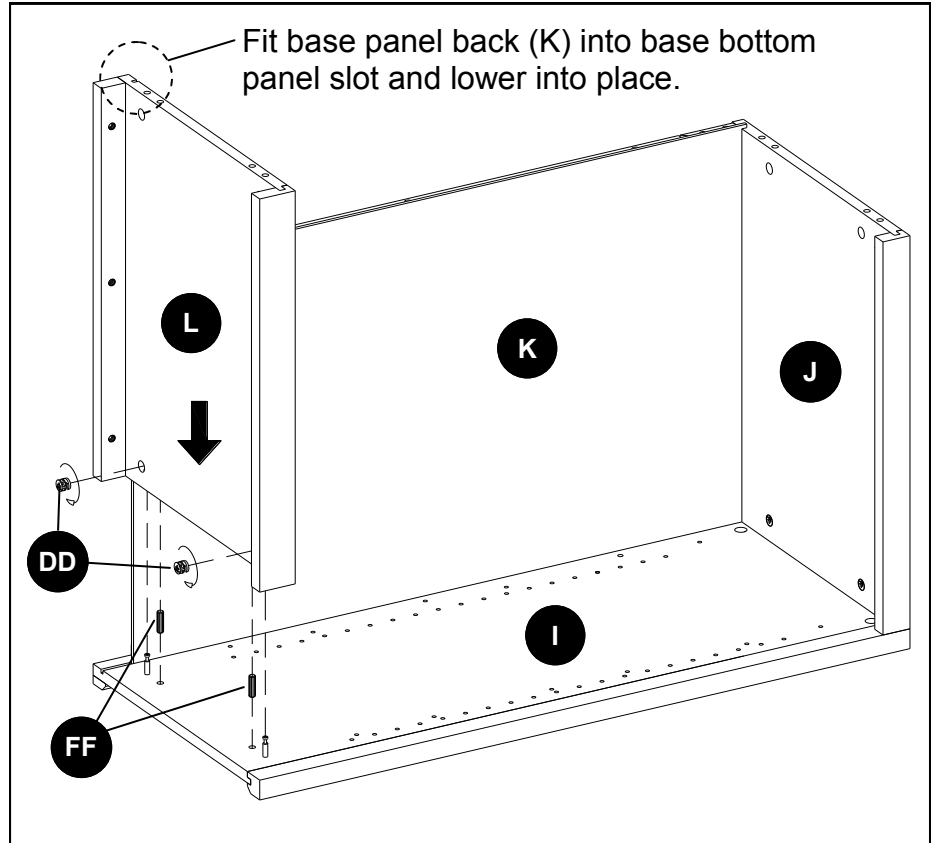
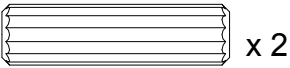

Step 6

Base assembly

DD Large Cam Lock



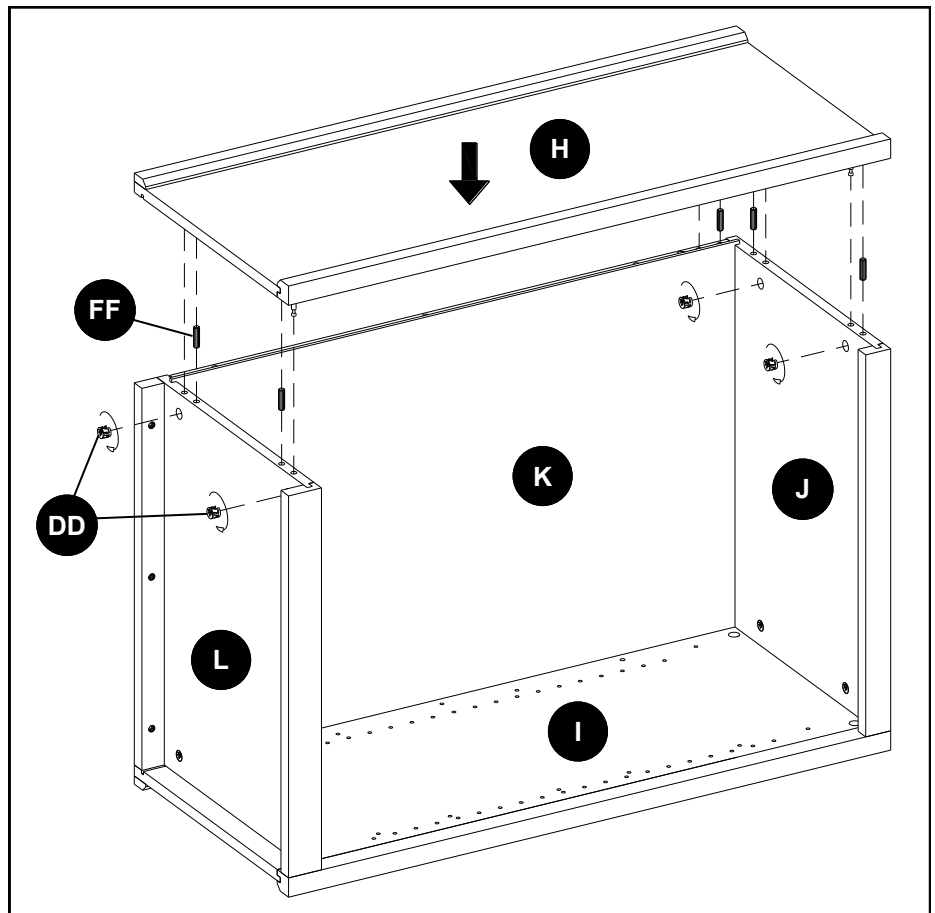
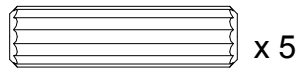

FF Large Wood Dowel

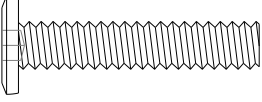

ASSEMBLY INSTRUCTIONS

Step 7 Base assembly

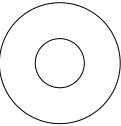
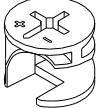
- AA** 1/4 x 1-1/4 in. Bolt
 x 3
- BB** Lock Washer
 x 3
- CC** Flat Washer
 x 3
- DD** Large Cam Lock
 x 1

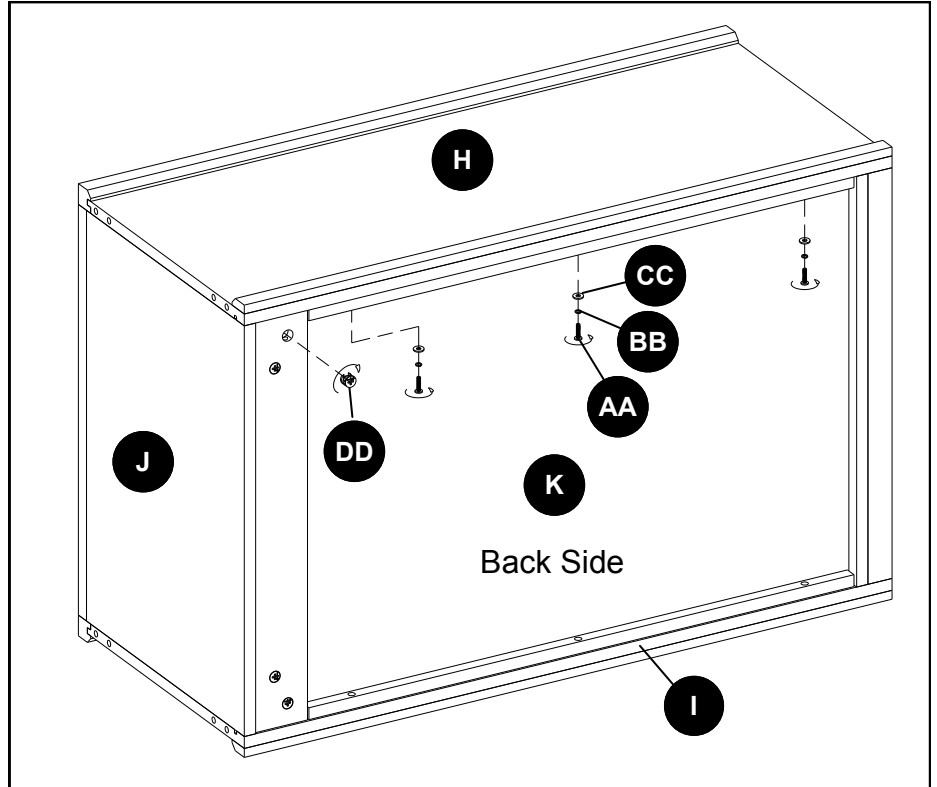

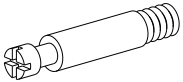

Step 1 Hutch assembly

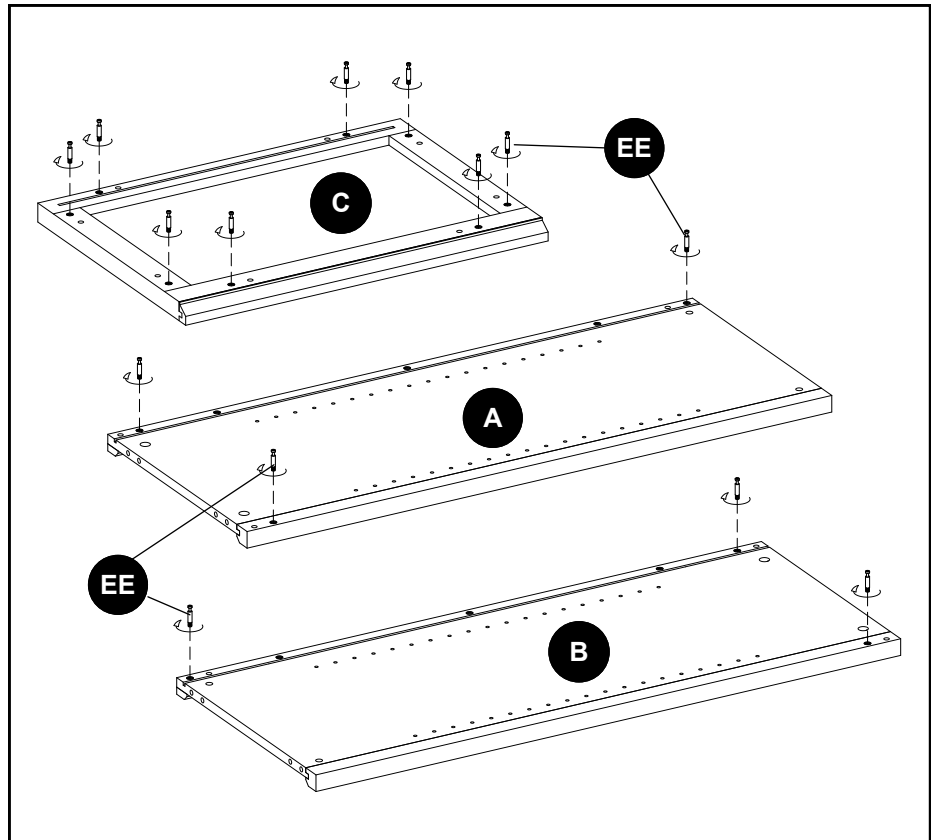
- EE** Medium Cam Bolt
 x 14

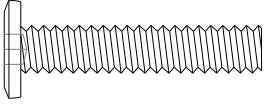

ASSEMBLY INSTRUCTIONS

Step 2 Hutch assembly

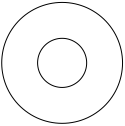
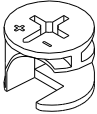
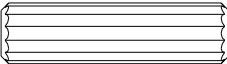
- AA** 1/4 x 1-1/4 in. Bolt  x 6
- BB** Lock Washer  x 6
- CC** Flat Washer  x 6
- DD** Large Cam Lock  x 6
- FF** Large Wood Dowel  x 6

Choose front curved stretcher (E) or front straight stretcher (F) depending on which fits your tower look and assemble per instructions below.

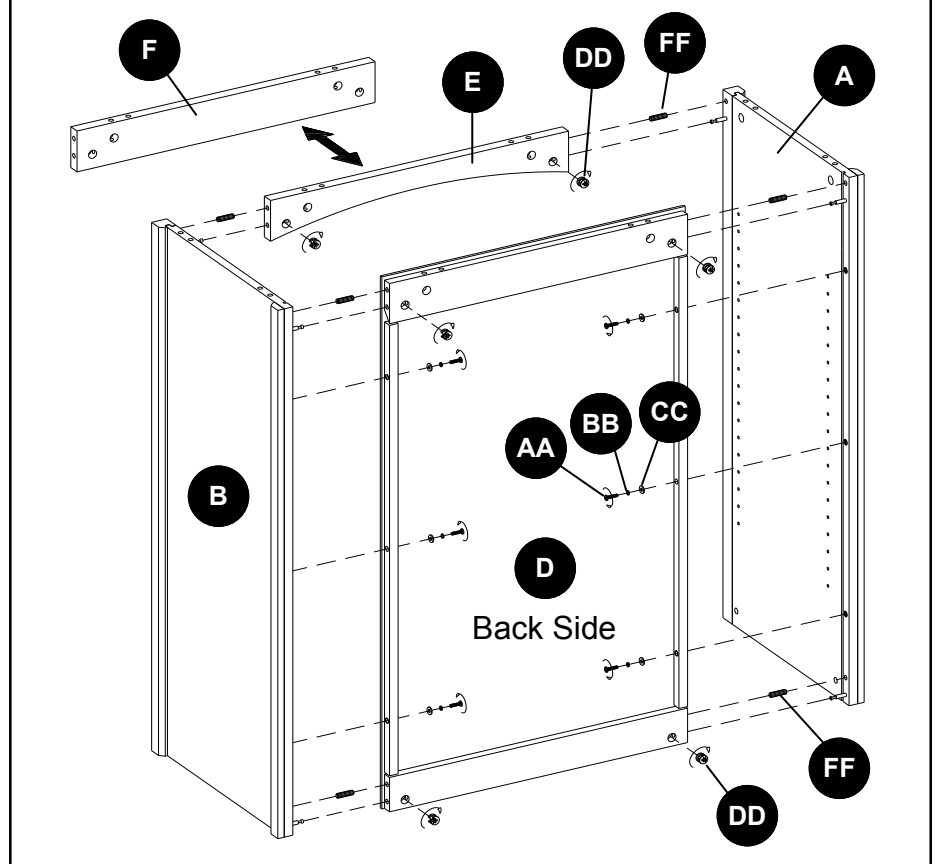

Step 3 Hutch assembly

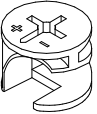
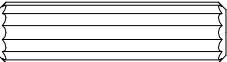
- DD** Large Cam Lock  x 8
- FF** Large Wood Dowel  x 8

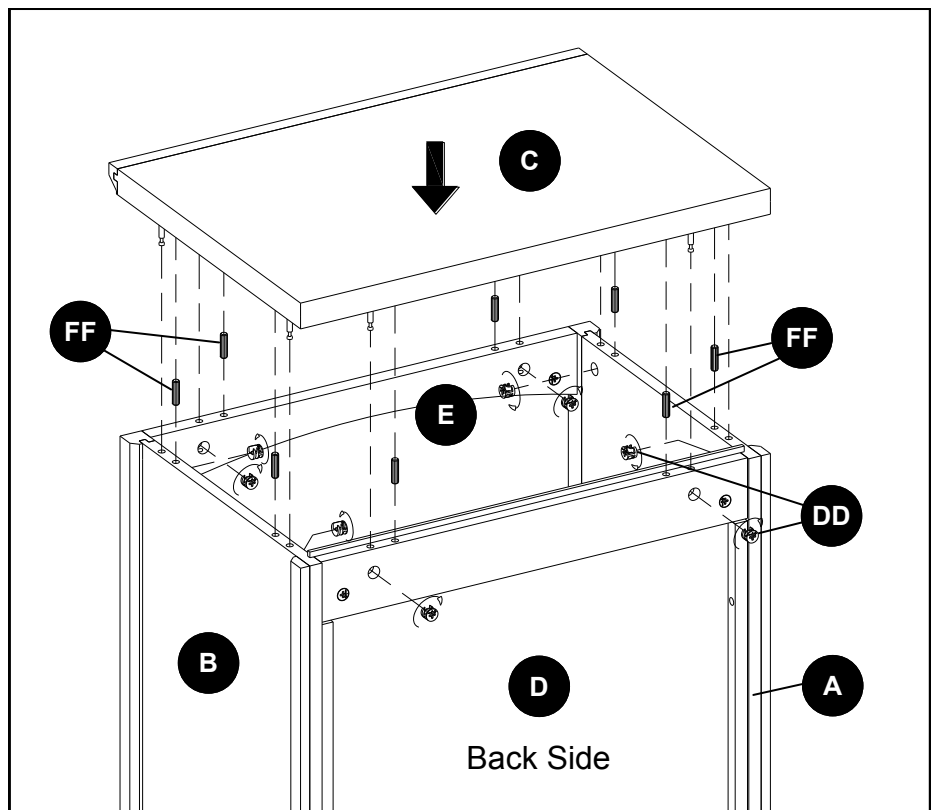

ASSEMBLY INSTRUCTIONS

Step 4 Hutch assembly

JJ Large Cam Bolt x 4

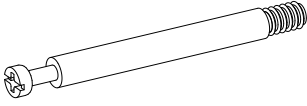

KK Barrel Nut x 4

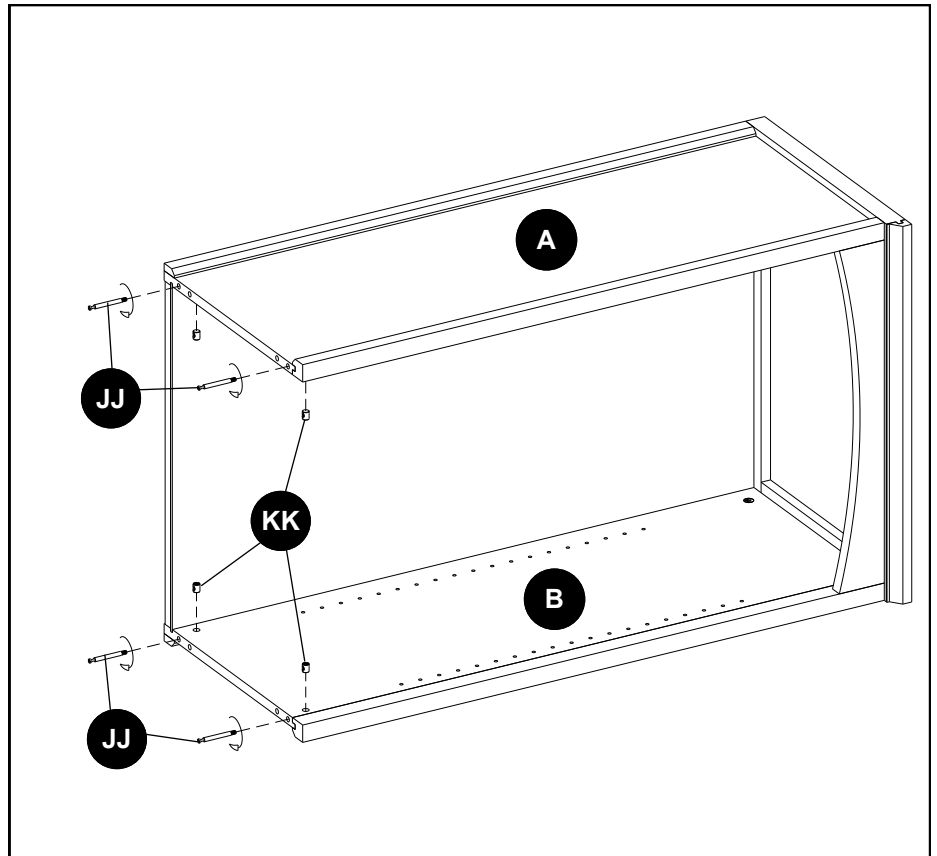
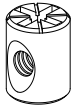

Step 5 Hutch assembly

DD Large Cam Lock x 4

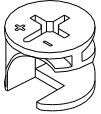

FF Large Wood Dowel x 4

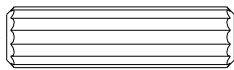

NOTE: Ask for help from your friend for this step.

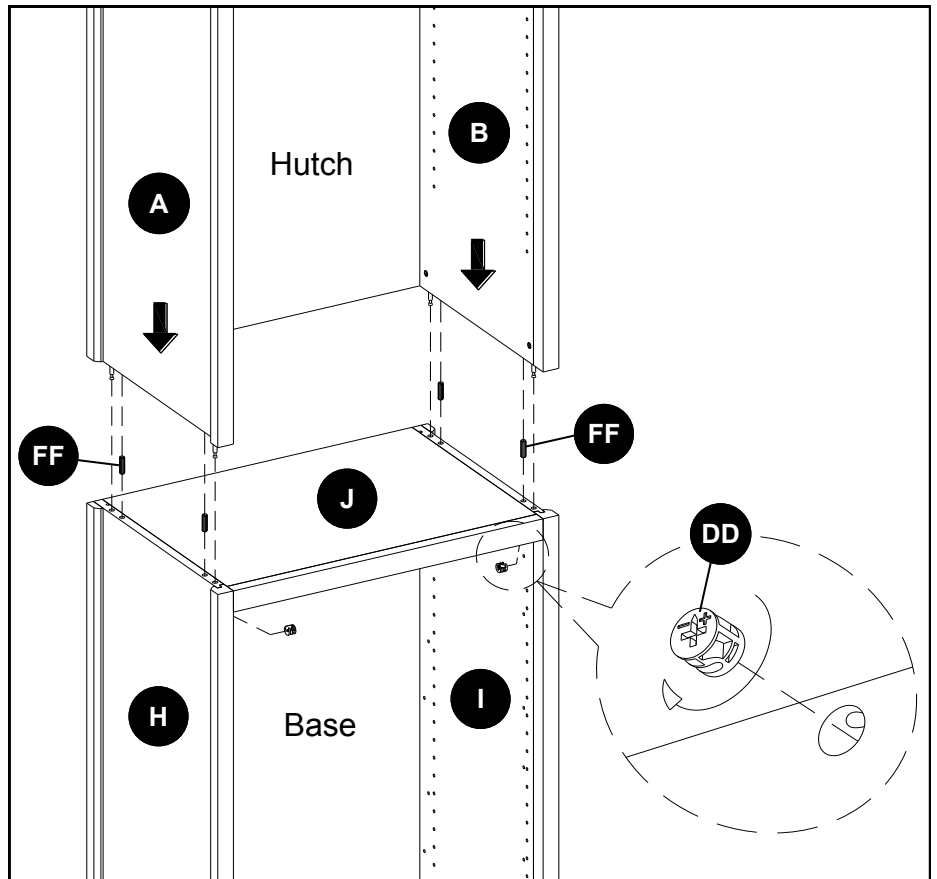

ASSEMBLY INSTRUCTIONS

Step 1 Wall Hanging installation

HH M8 x 2-1/2 in. Lag Bolt
x 4

II Large Flat Washer
x 4

Position the provided installation template (N) on desired location and carefully follow the directions on template to mark the installing holes. Make sure the bottom two installing holes location are more than 31-1/2 in. from the floor. Drill holes 2-1/2 in. deep with a 3/16 in. drill bit at the marked location.

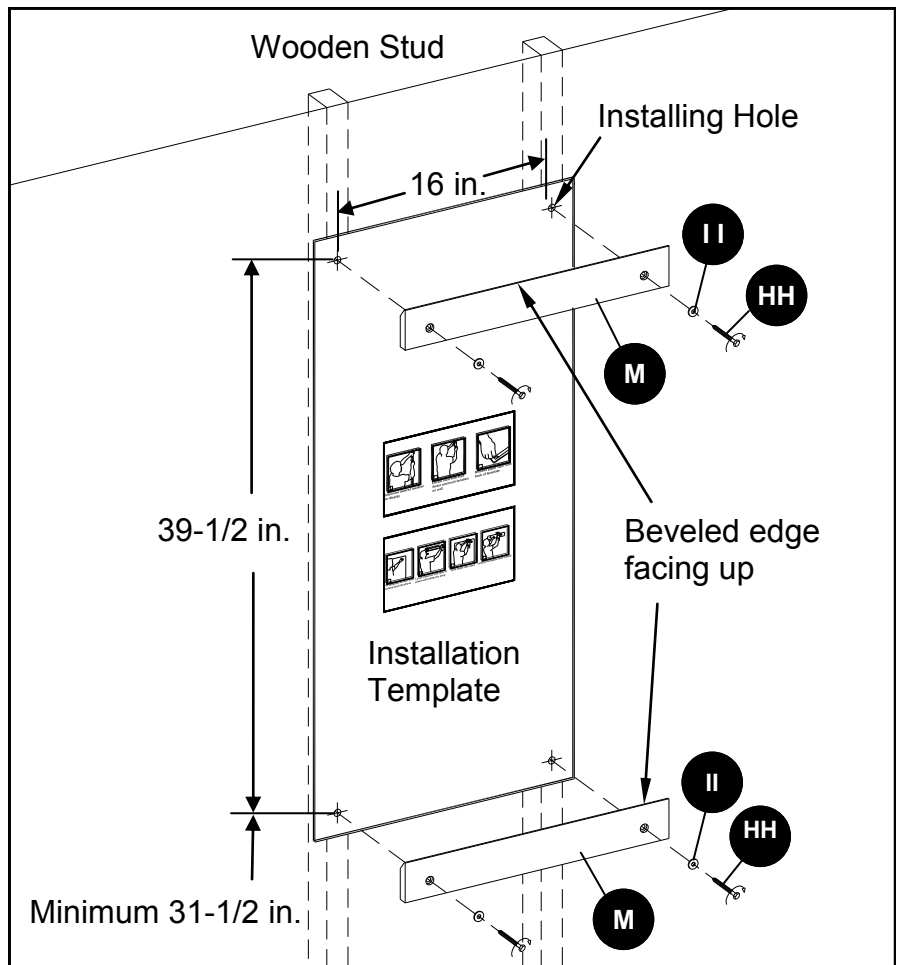

Step 2 Wall Hanging installation

NOTE: TWO OR MORE PERSONS MUST WORK TOGETHER TO INSTALL THE UNIT ONTO THE WALL.

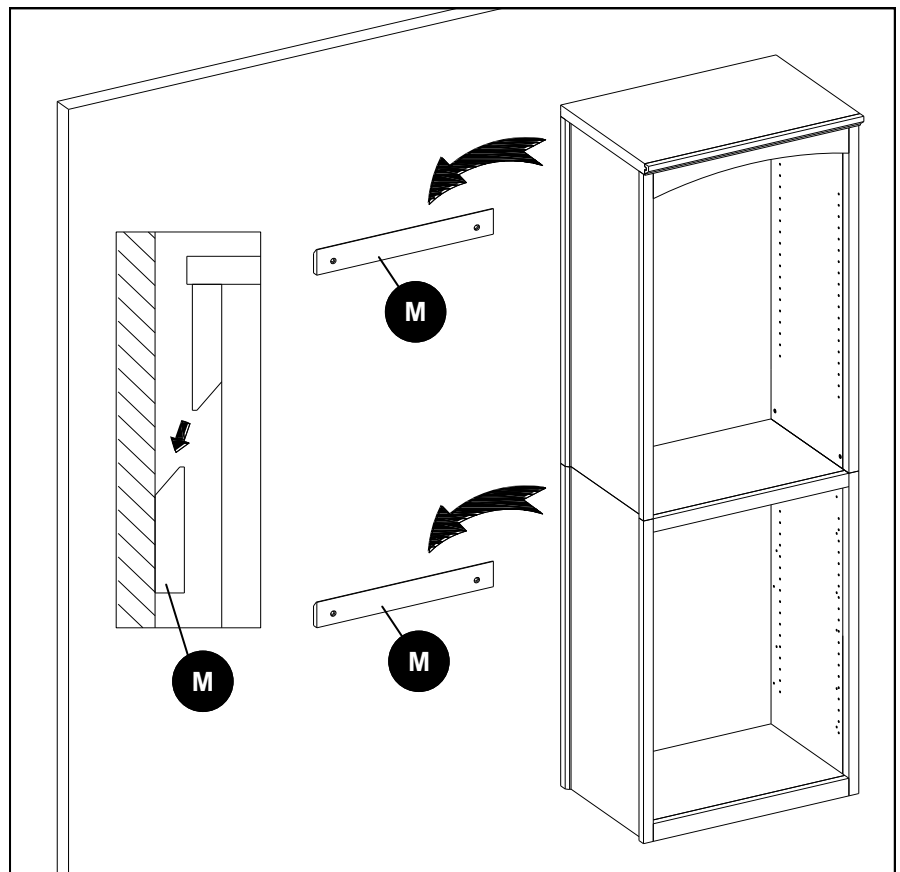

ASSEMBLY INSTRUCTIONS

Step 1

Adj. Shelf installation

GG Shelf Pin

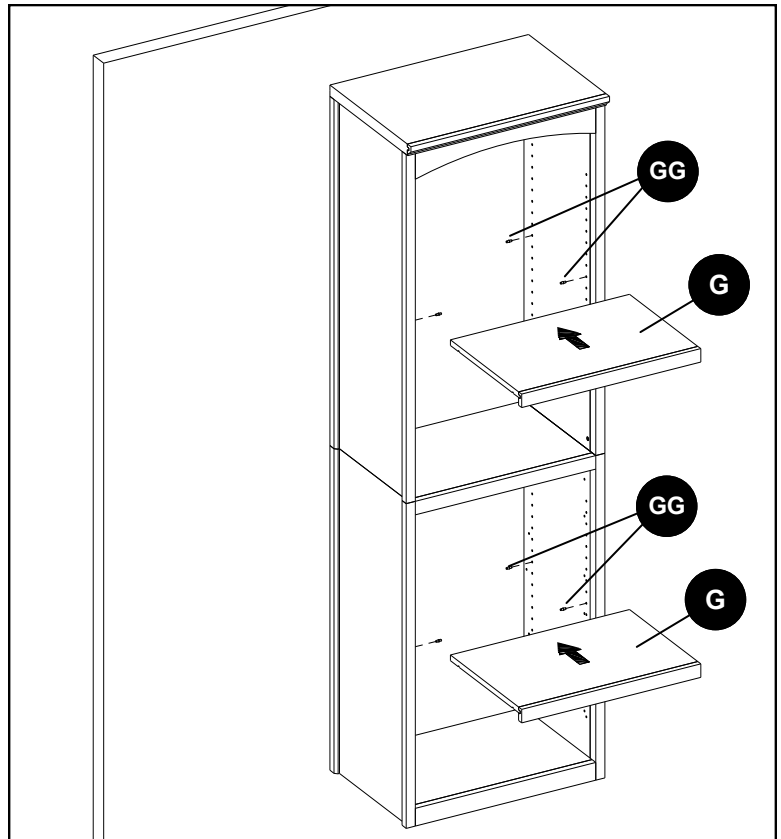
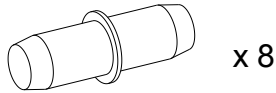

CARE AND MAINTENANCE

- Periodically check to make certain all components are properly positioned, free from damage and firmly connected.
- Use a soft, clean cloth that will not scratch the surface when dusting.
- Never use water to clean your furniture as it may cause damage to the finish.
- Wipe clean using a damp cloth and a mild cleaner. Wipe dry with a clean cloth.
- In the event that your furniture is stained or otherwise damaged during use, it is recommended that you call a professional to repair the furniture.
- Keep furniture away from direct sunlight as it may damage the finish.
- It is best to keep the furniture in a climate-controlled environment. Extreme temperature and humidity changes can cause fading, warping, shrinking and splitting of wood.
- Touch-up pen (MM) has been provided (except in item #0339209) to repair any small nicks or scratches that may occur during assembly or shipping.
- If Item #0339209 is damaged and touch-up is required, please apply a quality wood polish to the damaged surface. Polish not included with this item.

TROUBLESHOOTING

If you have any questions regarding the product, please call customer service at 1-866-439-9800, 8 a.m. - 8 p.m., EST, Monday - Friday.

PROBLEM	POSSIBLE CAUSE	CORRECTIVE ACTION
Closet tower tilted	The wall hanging cleats are not level.	Reinstall the wall hanging cleats and ensure they are level.
Closet tower can not hang on the wall	The mounting holes location are not correct.	Reinstall wall hanging cleats; make sure the space between two wall hanging cleats is 39-1/2 in. and the bottom two mounting holes location is more than 31-1/2 in. from the floor.

LIMITED LIFETIME WARRANTY

This product (exclusive of shelves) is warranted to the original purchaser. If there is a failure in this unit due to defects in materials or workmanship, the manufacturer will repair or replace this item at our discretion without charge. Warranty is void if product has been assembled incorrectly, misused, abused by overloading, altered in any way or damaged due to accident. This warranty is not transferable and does not cover chipping, flaking, scratches, rust, dents, or other damages to the surfaces of this product. Responsibility of the manufacturer is limited to repair or replacement of this product. The manufacturer is not responsible for consequential, incidental, or other damages or losses resulting from product failure.

This warranty is in lieu of all other expressed warranties. Some states do not allow the exclusion or limitation of incidental or consequential damages, so the above limitation may not apply to you. This warranty gives you specific legal rights and you may have other rights which vary from state to state.

REPLACEMENT PARTS LIST

For replacement parts, call our customer service department at 1-866-439-9800, 8 a.m. - 8 p.m., EST, Monday - Friday.

PART	DESCRIPTION	PART #
A	Hutch Panel Left	*WSWS-WU1C/W/P/S-1-HPL
B	Hutch Panel Right	*WSWS-WU1C/W/P/S-2-HPR
C	Hutch Panel Top	*WSWS-WU1C/W/P/S-3-HPT
D	Hutch Panel Back	*WSWS-WU1C/W/P/S-4-HPB
E	Front Curved Stretcher	*WSWS-WU1C/W/P/S-5-FCS
F	Front Straight Stretcher	*WSWS-WU1C/W/P/S-6-FCS
G	Adjustable Shelf	*WSWS-WU1C/W/P/S-7-AS
H	Base Panel Left	*WSWS-WU1C/W/P/S-8-BPL
I	Base Panel Right	*WSWS-WU1C/W/P/S-9-BPR
J	Base Panel Top	*WSWS-WU1C/W/P/S-10-BPT
K	Base Panel Back	*WSWS-WU1C/W/P/S-11-BPB
L	Base Panel Bottom	*WSWS-WU1C/W/P/S-12-BPB
M	Wall Hanging Cleat	*WSWS-WU1C/W/P/S-13-WHC
N	Installation Template	*WSWS-WU1C/W/P/S-26-IT
AA	1/4 x 1-1/4 in. Bolt	*WSWS-WU1C/W/P/S-15-1-1/4B
BB	Lock Washer	*WSWS-WU1C/W/P/S-16-LW
CC	Flat Washer	*WSWS-WU1C/W/P/S-17-FW
DD	Large Cam Lock	*WSWS-WU1C/W/P/S-18-LCL
EE	Medium Cam Bolt	*WSWS-WU1C/W/P/S-19-MCB

PART	DESCRIPTION	PART #
FF	Large Wood Dowel	*WSWS-WU1CW/P/S-20-LWD
GG	Shelf Pin	*WSWS-WU1CW/P/S-21-SP
HH	M8 x 2-1/2 in. Lag Bolt	*WSWS-WU1CW/P/S-22-2-1/2LB
II	Large Flat Washer	*WSWS-WU1CW/P/S-23-LFW
JJ	Large Cam Bolt	*WSWS-WU1CW/P/S-26-LCB
KK	Barrel Nut	*WSWS-WU1CW/P/S-27-BN
LL	M4 Allen Wrench	*WSWS-WU1CW/P/S-24-M4AW
MM	Touch-up Pen	*WSWS-WU1CW/S-25-TUP
	Complete Hardware	*WSWS-WU1CW/P/S-14-CH

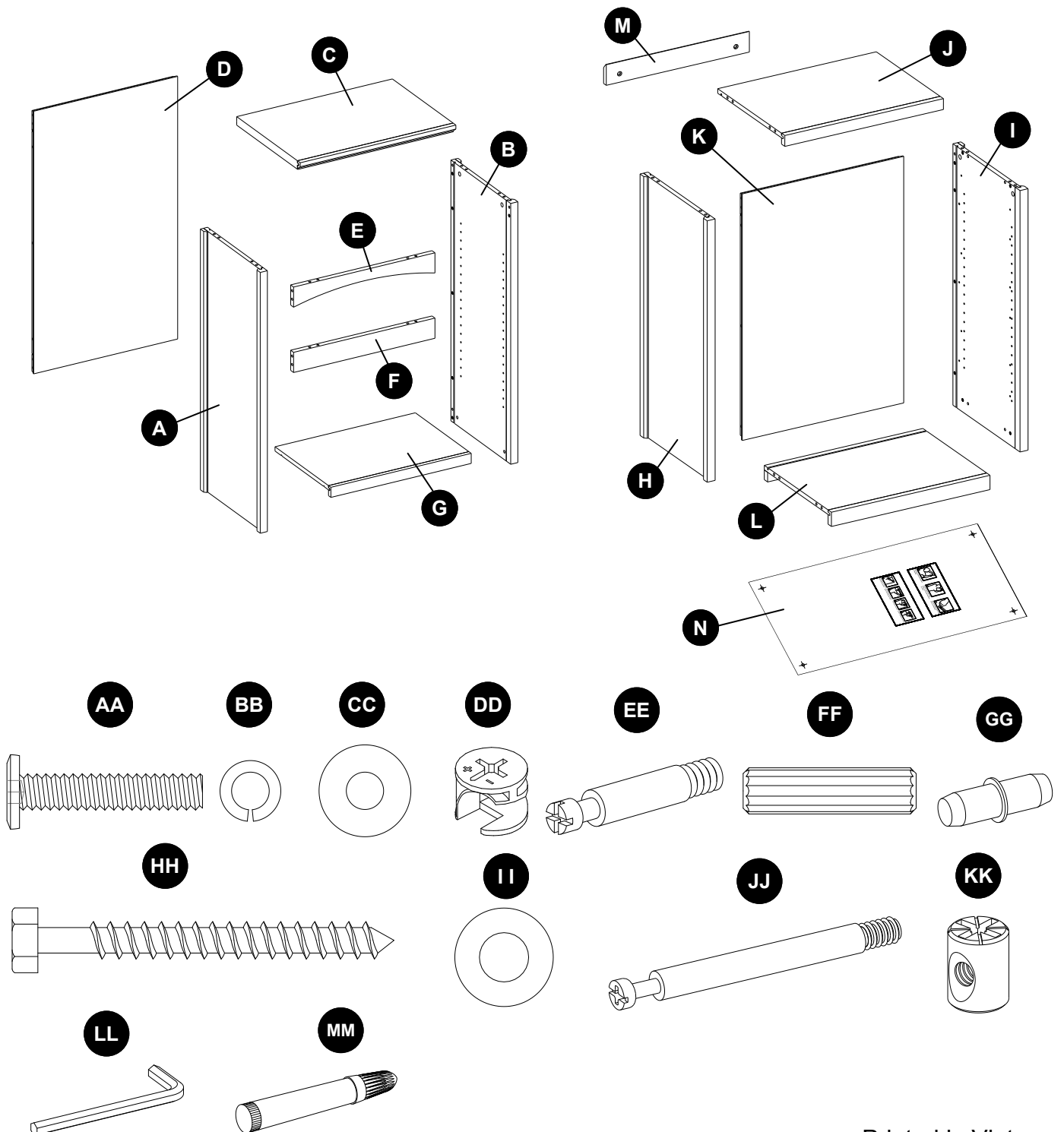

Printed in Vietnam

allen + rothTM
classic style with a modern twistTM

ARTICLES N° 0339207, 0339208, 0339209, 0339210

TOUR EN BOIS HAUT DE GAMME

MODEL N° WSWW-WU1C, WSWW-WU1W
WSWW-WU1P, WSWW-WU1S

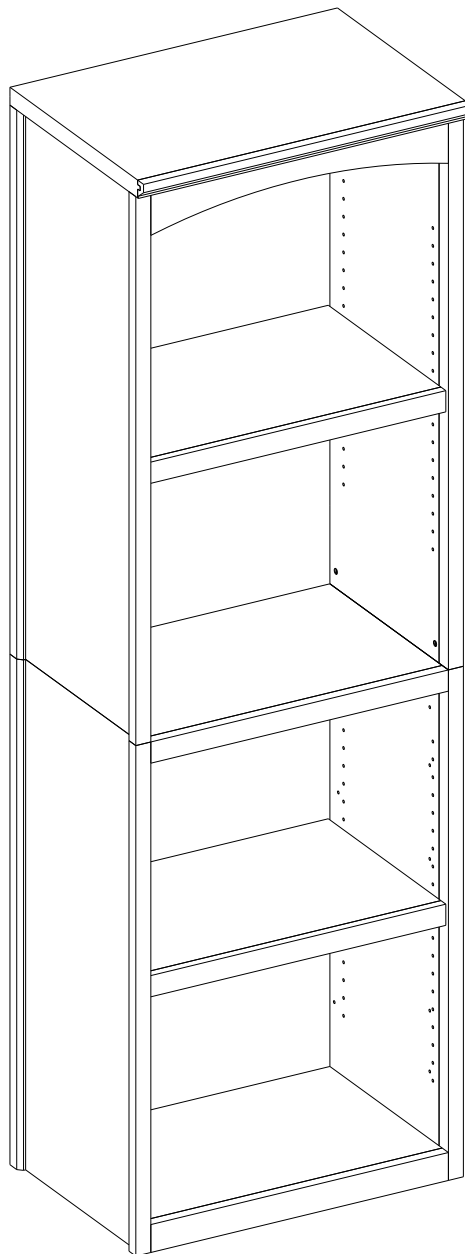

JOINDRE VOTRE REÇU ICI

Numéro de série _____ Date d'achat _____



Question, problèmes, pièces manquantes ? Avant de retourner au détaillant, communiquer avec notre service à la clientèle au 1-866-439-9800 entre 8 h 00 et 20 h 00, Heure de l'Est, du lundi au vendredi.

TABLE DES MATIÈRES

Fonctionnement du système à came	17
Contenu de la boîte	18
Contenu de la quincaillerie	19
Consignes de sécurité	20
Préparation	20
Directives de montage	21
Soin et entretien	28
Diagnostic	28
Garantie	29
Liste des pièces de remplacement	29

FONCTIONNEMENT DU SYSTÈME À CAME

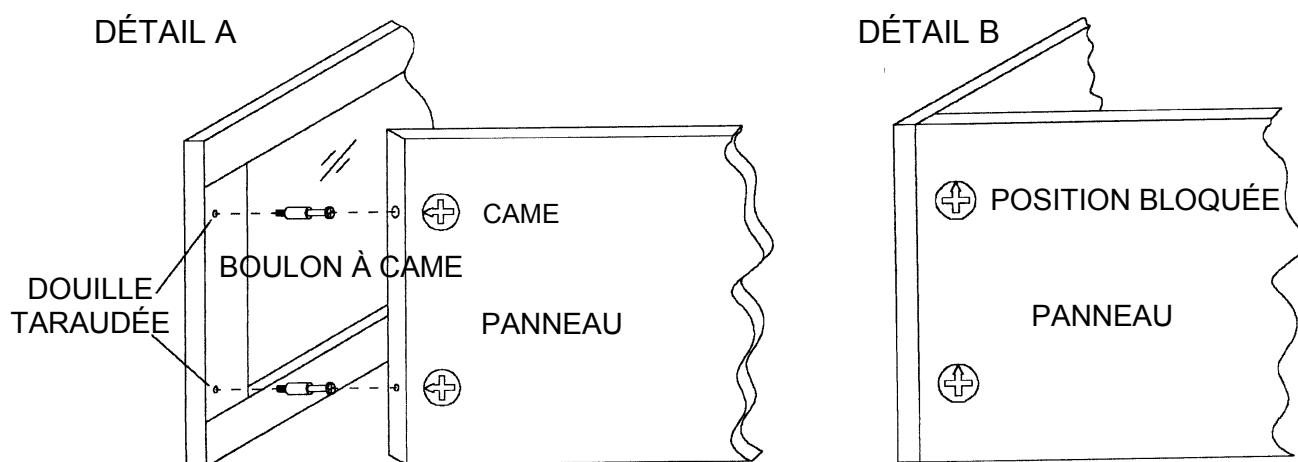

1. Visser un boulon à came dans le petit trou déjà percé sur le panneau.
2. Insérer la came dans le grand trou déjà percé sur le panneau.
3. S'assurer que la flèche sur la came soit orientée vers le boulon à came.
4. Relier les deux panneaux en s'assurant que le boulon à came s'insère dans le trou déjà percé à l'extrémité du panneau avec la came.
5. Une fois le boulon à came en place, tourner la came dans le sens des aiguilles d'une montre pour serrer avec un tournevis à pointe cruciforme.

CONTENU DE LA BOÎTE

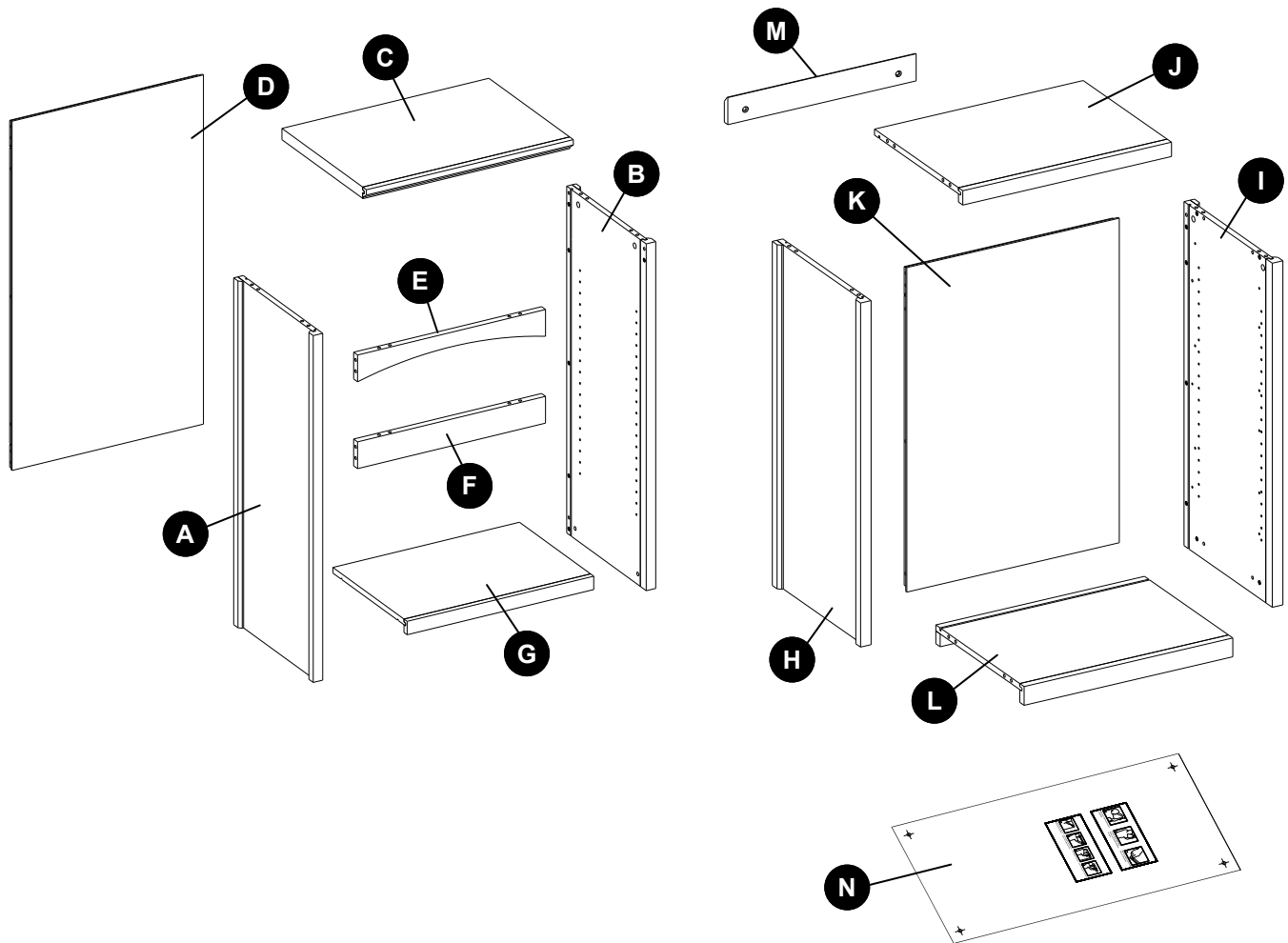

PIÈCE	DESCRIPTION	QTÉ
A	Panneau gauche de huche	1
B	Panneau droit de huche	1
C	Panneau supérieur de huche	1
D	Panneau arrière de huche	1
E	Entretoise avant courbée	1
F	Entretoise avant droite	1
G	Tablette réglable	2

PIÈC	DESCRIPTION	QTÉ
H	Panneau gauche de la base	1
I	Panneau droit de la base	1
J	Panneau supérieur de la base	1
K	Panneau arrière de la base	1
L	Panneau inférieur de la base	1
M	Tasseau de suspension	2
N	Gabarit d'installation	1

CONTENU DE LA QUINCAILLERIE

AA

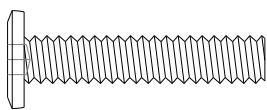

Boulon
1/4 x 1 1/4 po

Qté 12

BB



Rondelle
frein

Qté 12

CC

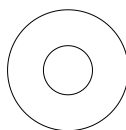

Rondelle
plate

Qté 12

DD



Grande
came

Qté 34

EE

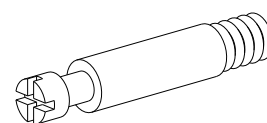

Medium boulon
à came

Qté 30

FF

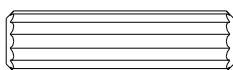

Grand goujon
de bois

Qté 34

GG

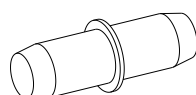

Taquet de
tablette

Qté 8

HH

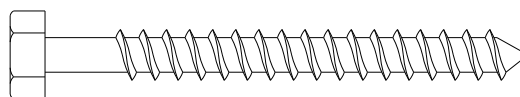

Tire-fond
M8 x 2 1/2 po

Qté 4

II

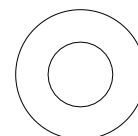

Grande
rondelle plate

Qté 4

JJ

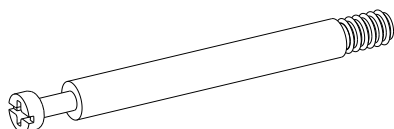

Grand boulon
à came

Qté 4

KK

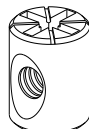

Écrou
cylindrique

Qté 4

LL

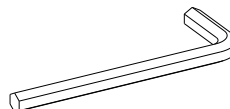

Clé hexagonale
M4

Qté 1

MM

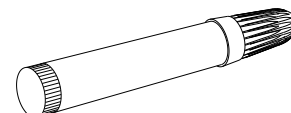

Crayon à retouche

Qté 1
(non inclus pour
article n° 0339209)



CONSIGNES DE SÉCURITÉ

Lire et comprendre le présent guide avant de procéder au montage.

1. Ne pas laisser les enfants grimper ni jouer sur ou autour de ce produit.
2. Utiliser cette unité pour l'usage visé seulement. Ne pas utiliser les tablettes pour grimper.
3. Pour éviter les dommages, assembler le produit sur une surface solide, de niveau et protégée.
4. Au moins deux personnes doivent travailler ensemble pour installer l'unité sur le mur.
5. S'assurer que tous les boulons et les vis soient serrés à fond avant d'utiliser l'unité.
6. Vérifier les boulons et les vis régulièrement et serrer, au besoin.

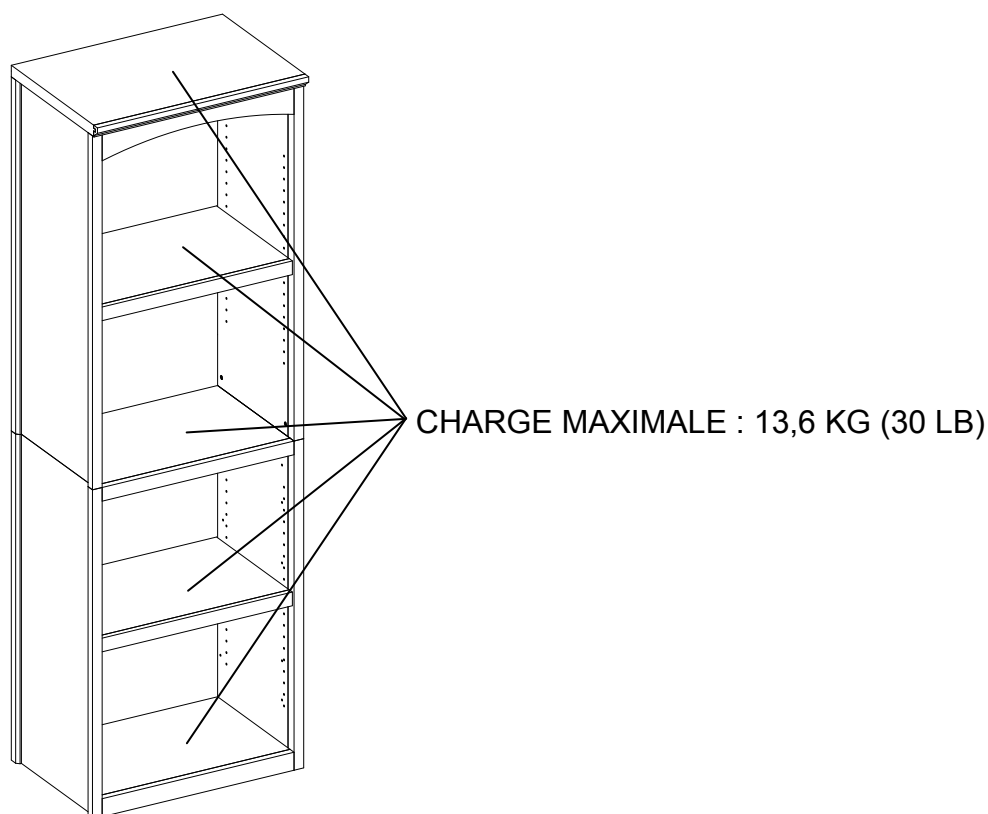

⚠ AVERTISSEMENT

CETTE UNITÉ EST DESTINÉE À ÊTRE UTILISÉE UNIQUEMENT AVEC LES POIDS MAXIMAUX INDICQUÉS. L'UTILISATION AVEC DES PRODUITS PLUS LOURDS QUE LES POIDS MAXIMAUX INDICQUÉS PEUT RENDRE L'UNITÉ INSTABLE ET CAUSER DES BLESSURES. RÉPARTIR LE POIDS ÉGALEMENT.

PRÉPARATION

Avant de débuter l'installation du produit, s'assurer d'avoir toutes les pièces. Comparer les pièces avec la liste des pièces et de la quincaillerie. En cas de pièce manquante ou endommagée, ne pas tenter d'assembler, d'installer ni d'utiliser le produit. Communiquer avec le service à la clientèle pour obtenir des pièces de remplacement.

Durée approximative du montage : 60 minutes

Outils requis pour le montage (non inclus) : tournevis à pointe cruciforme, niveau, perceuse, mèche 4,8 mm (3/16 po), mèche 9,5 mm (3/8 po), clé à douille 1,3 cm (1/2 po), détecteur de montant, crayon, ruban à mesurer, échelle et marteau.

Étape 1

Montage de la base

EE Medium boulon à came

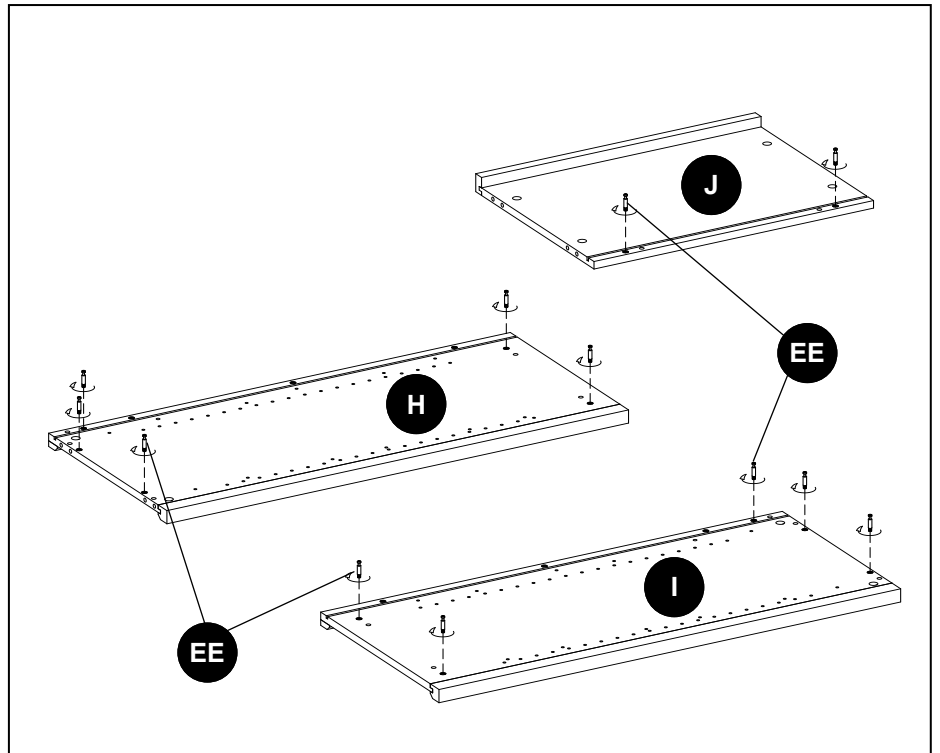
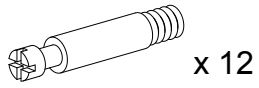

Étape 2

Montage de la base

DD Grande came

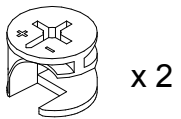

FF Grand goujon de bois

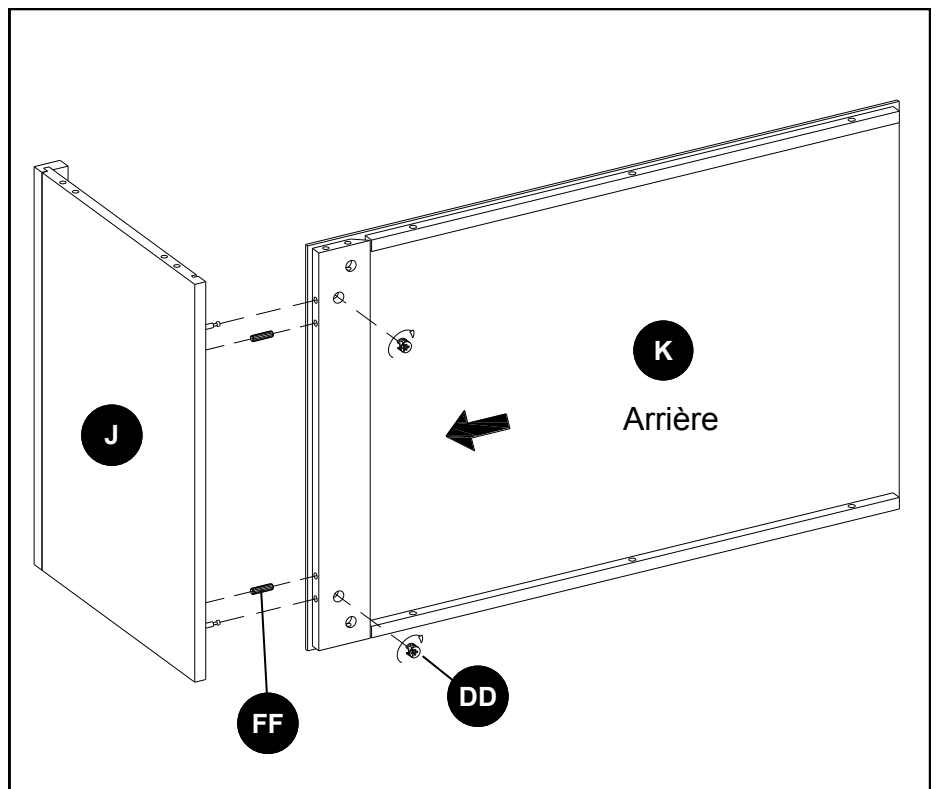
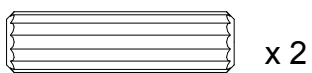

Étape 3

Montage de la base

DD Grande Came

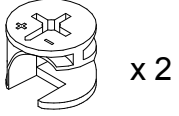

FF Grand goujon de bois

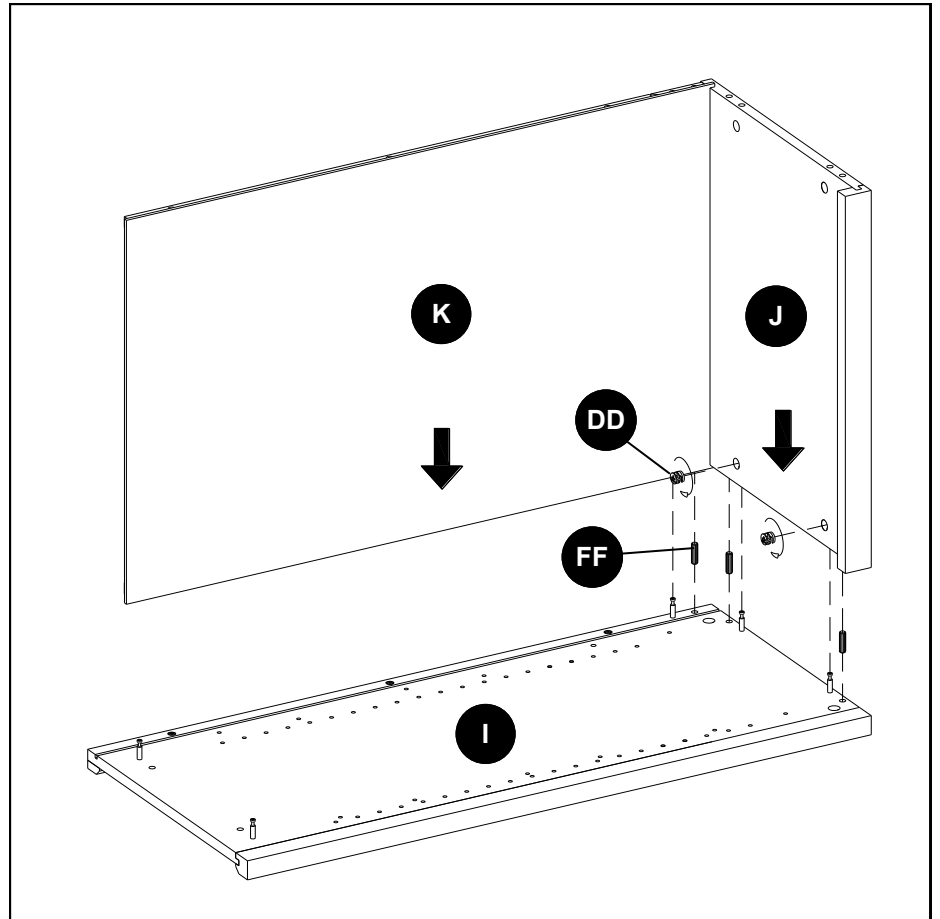

Étape 4

Montage de la base

AA Boulon $\frac{1}{4}$ x $1 \frac{1}{4}$ po

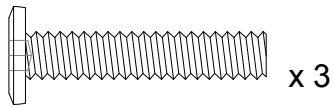

BB Rondelle frein



CC Rondelle plate

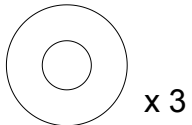

DD Grande came

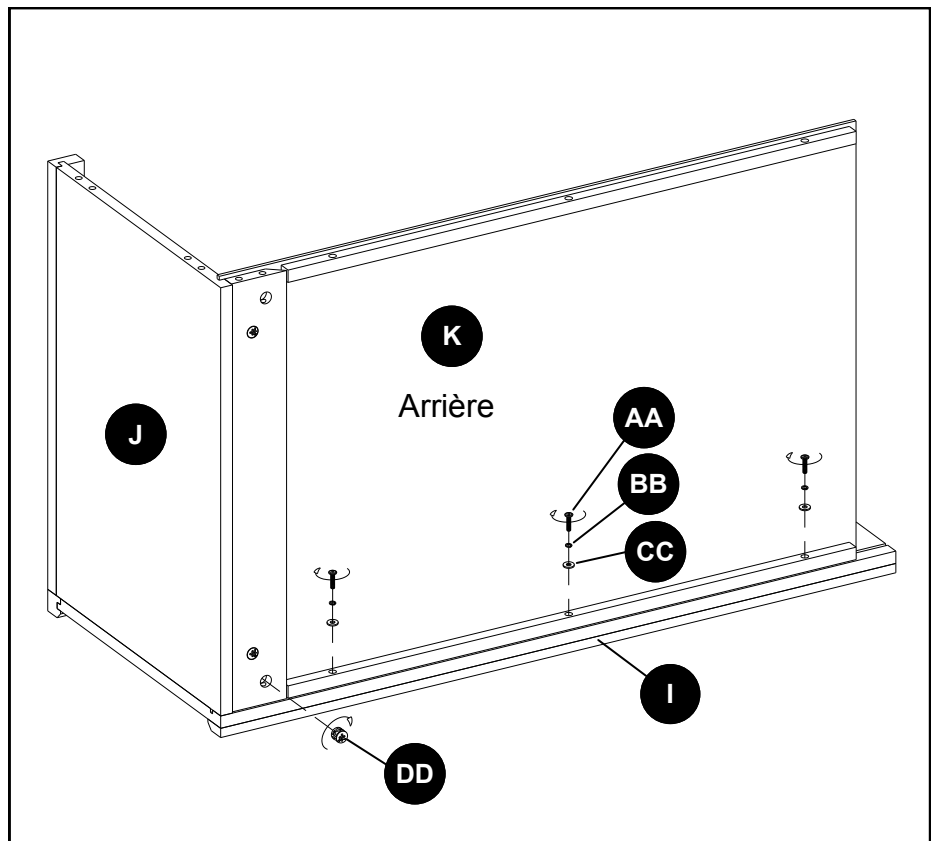
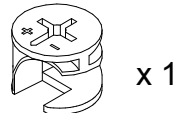

Étape 5

Montage de la base

DD Grande came

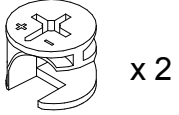

FF Grand goujon de bois

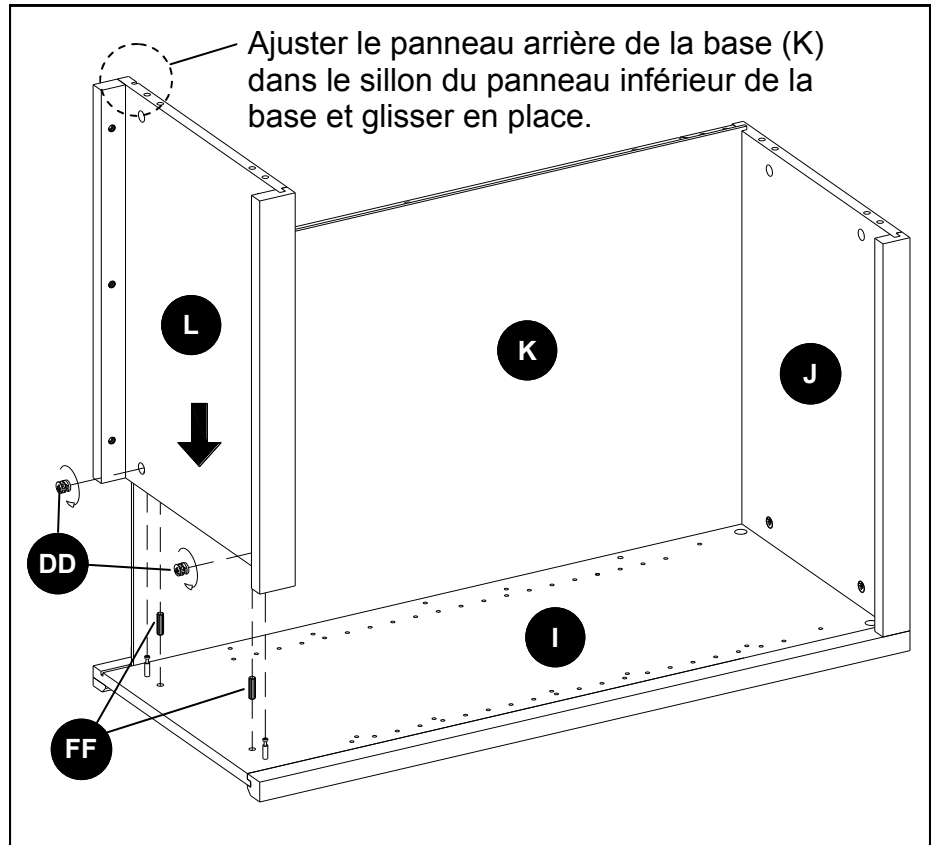
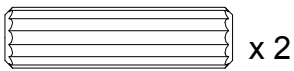

Étape 6

Montage de la base

DD Grande came



FF Grand goujon de bois

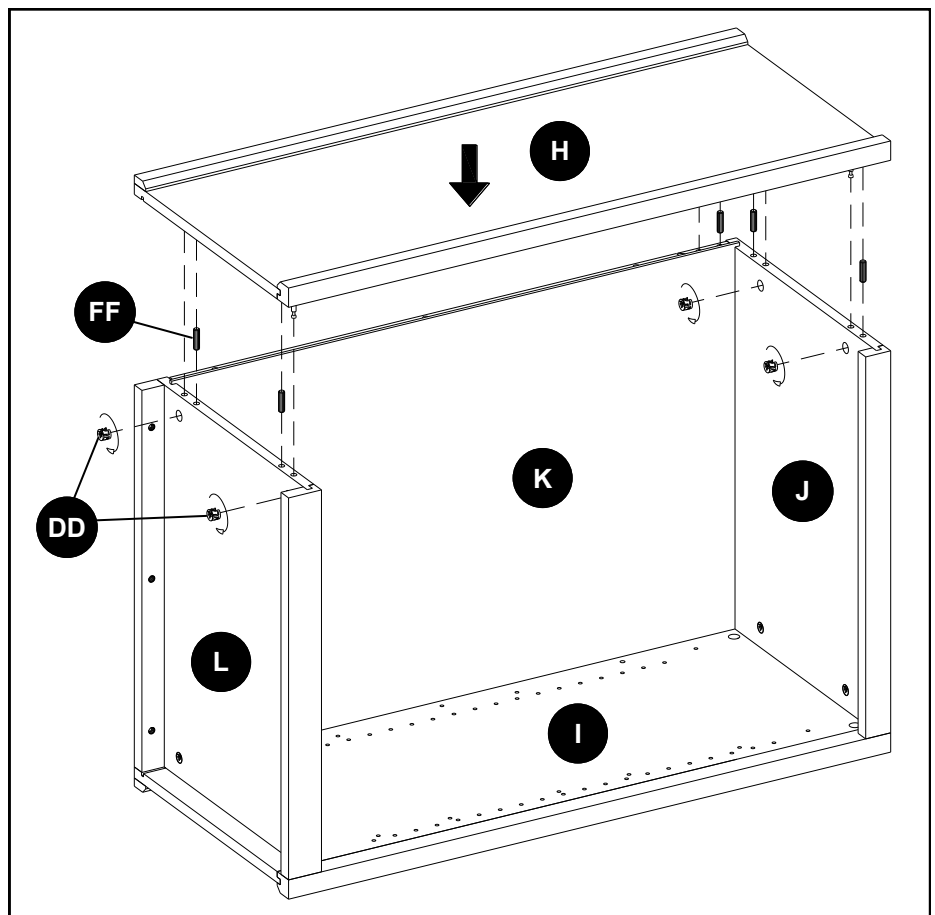
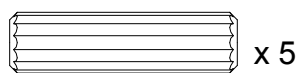

Étape 7

Montage de la base

AA Boulon $\frac{1}{4}$ x $1 \frac{1}{4}$ po

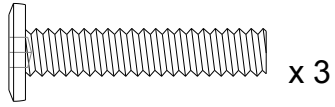

BB Rondelle frein



CC Rondelle plate

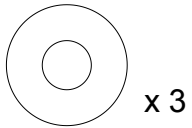

DD Grande came

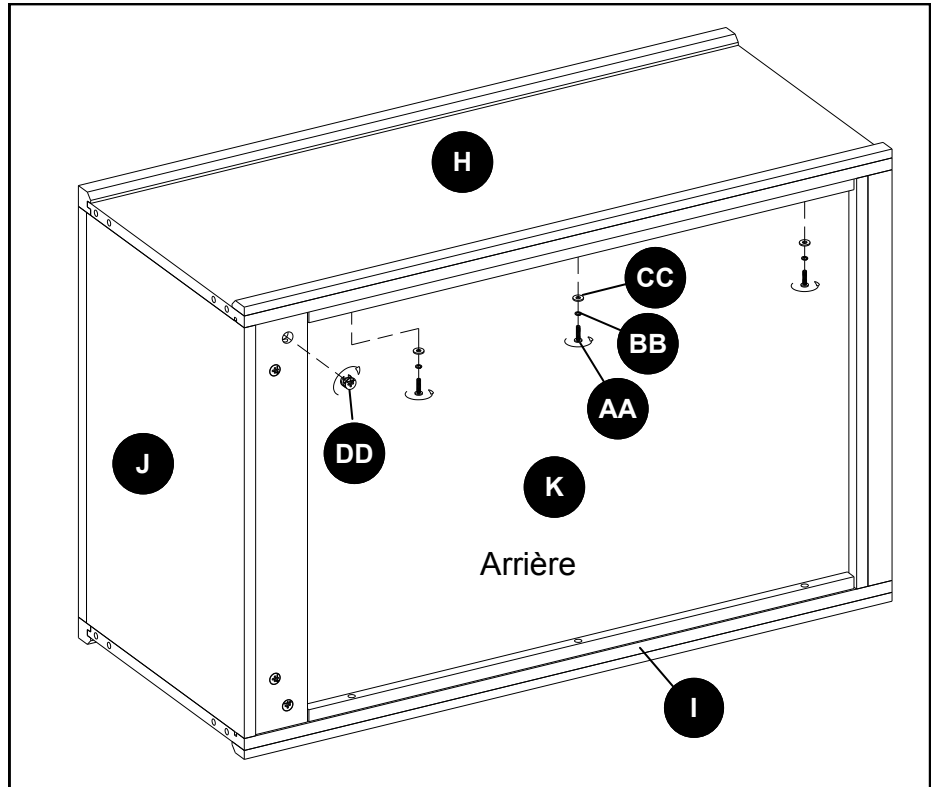

Étape 1

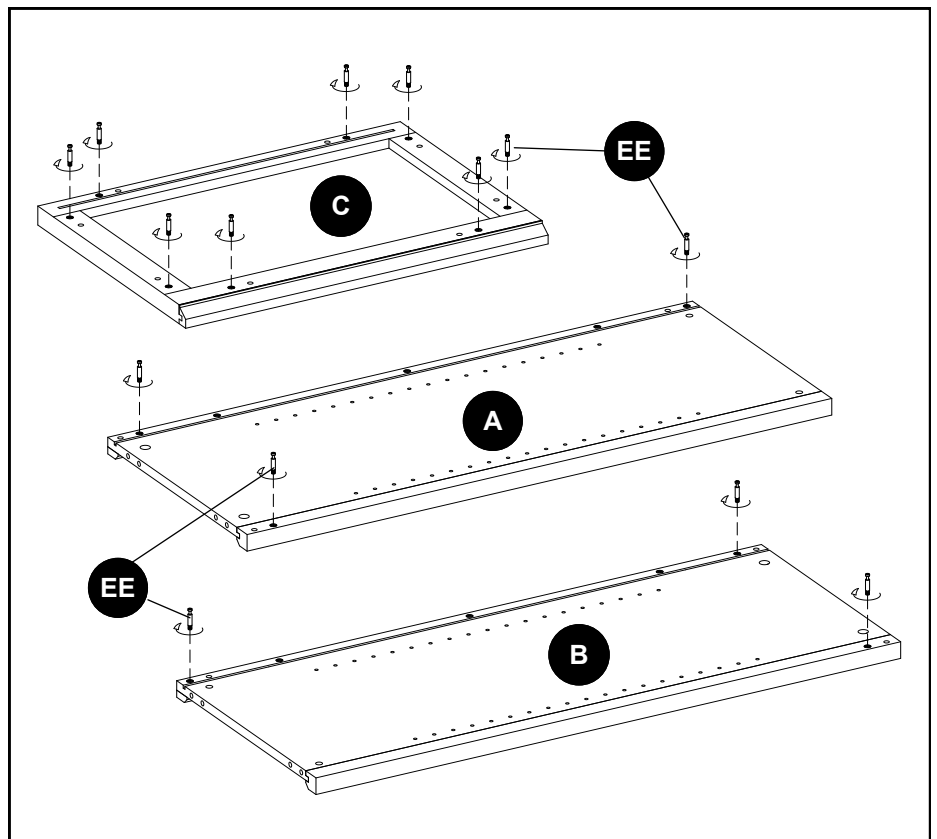
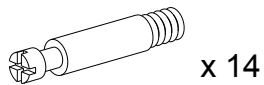

Montage de la huche

EE Medium boulon à came

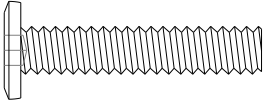

Étape 2

Montage de la huche

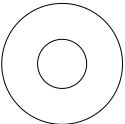
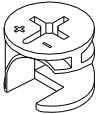
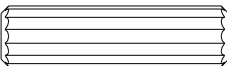
- AA** Boulon $\frac{1}{4}$ x $1\frac{1}{4}$ po
 x 6
- BB** Rondelle frein
 x 6
- CC** Rondelle plate
 x 6
- DD** Grande came
 x 6
- FF** Grand goujon de bois
 x 6

Choisir l'entretoise avant courbée (E) ou l'entretoise avant droite (F) selon l'aspect de votre placard et assembler selon les directives plus bas.

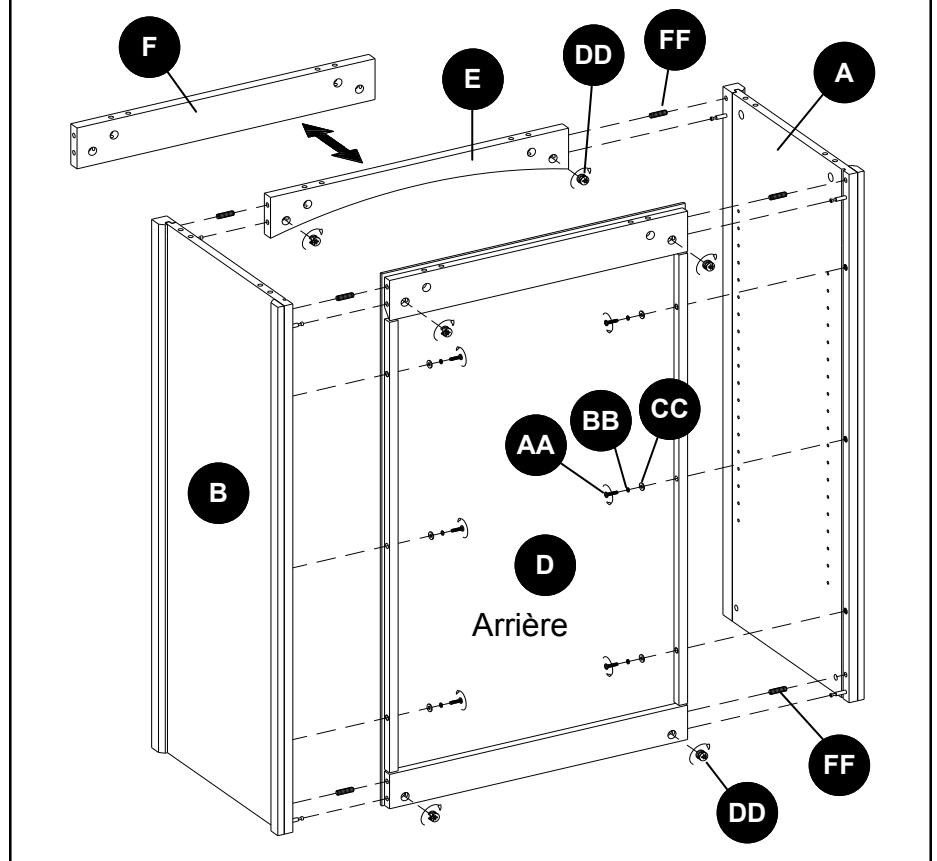

Étape 3

Montage de la huche

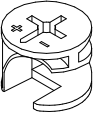
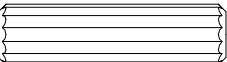
- DD** Grande came
 x 8
- FF** Grand goujon de bois
 x 8

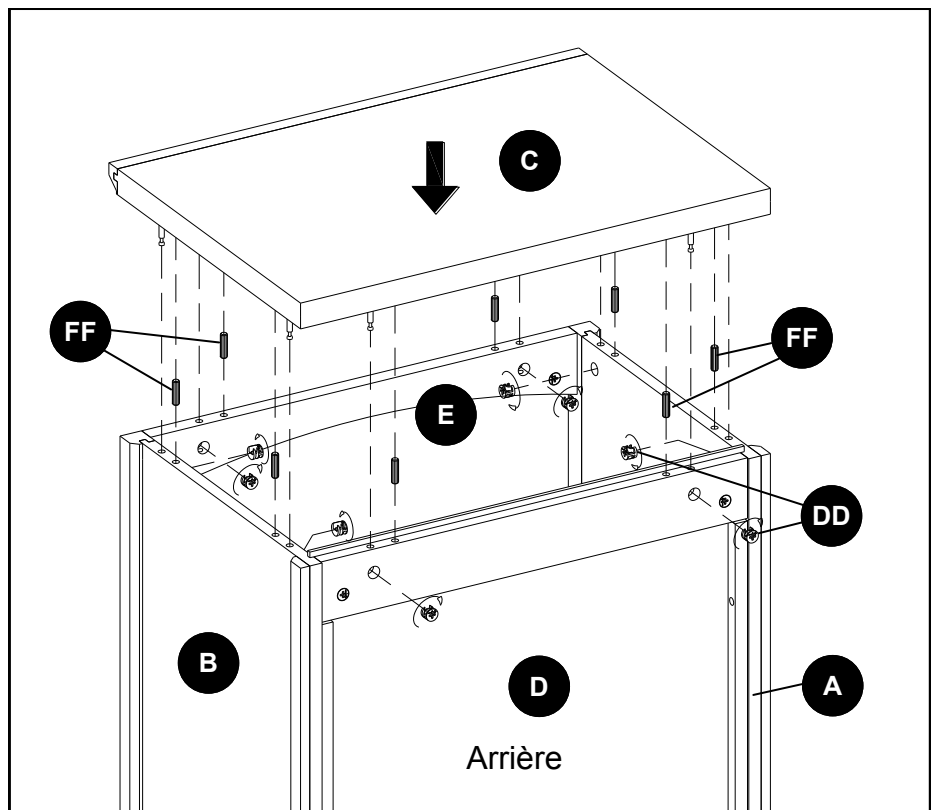

Étape 4
Montage de la huche

JJ Grand boulon à came x 4

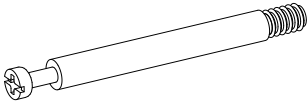

KK Écrou cylindrique x 4

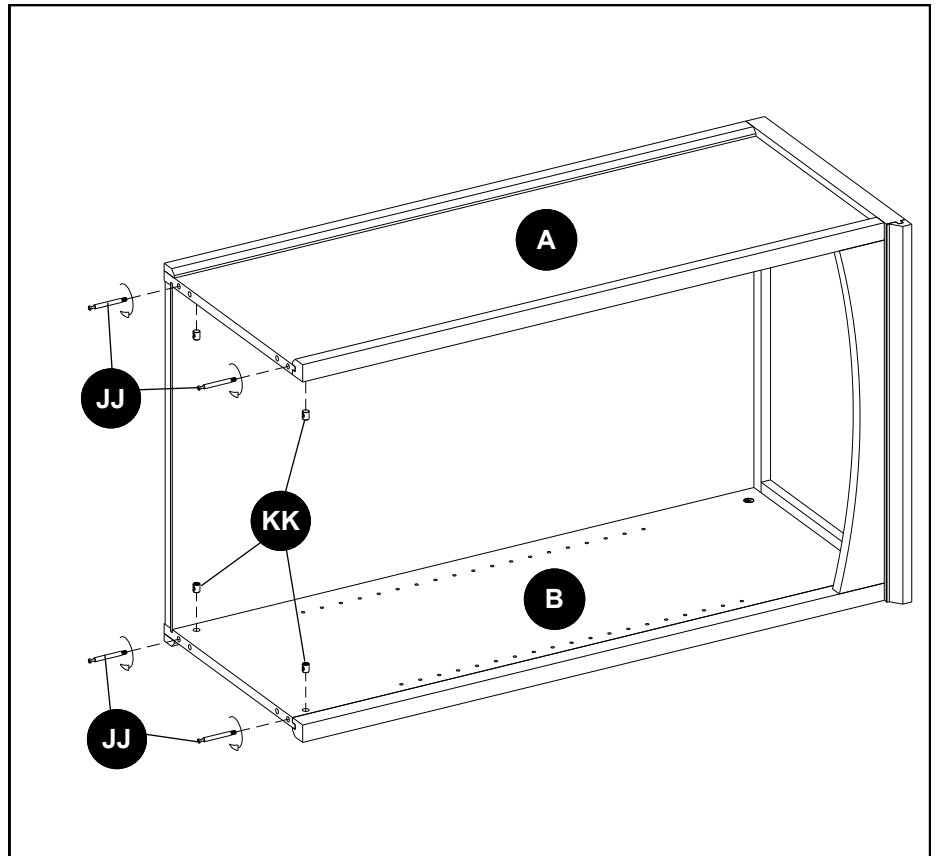
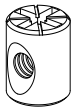

Étape 5
Montage de la huche

DD Grande came x 4



FF Grand goujon de bois x 4

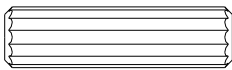

NOTE : Demander de l'aide pour cette étape.

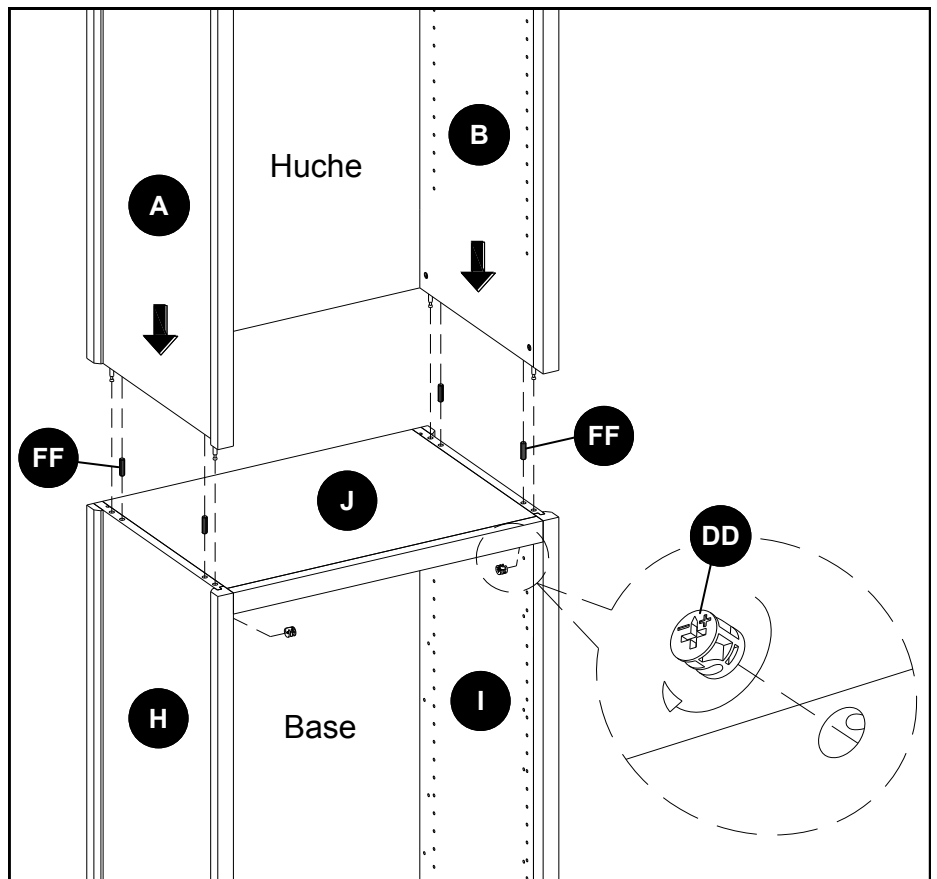

DIRECTIVES DE MONTAGE

Étape 1

Installation au mur

HH Tire-fond M8 x 2 ½ po

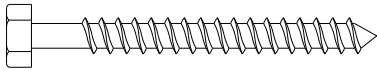

x 4

II Grande rondelle plate

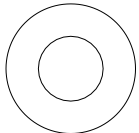

x 4

Placer le gabarit d'installation (N) à l'emplacement désiré et suivre attentivement les directives du gabarit pour indiquer l'emplacement des trous pour l'installation. S'assurer que l'emplacement des deux trous inférieurs soit à plus de 31 ½ po du plancher. Percer des trous de 2 ½ po de profondeur avec une mèche de perceuse 3/16 po à l'emplacement indiqué.

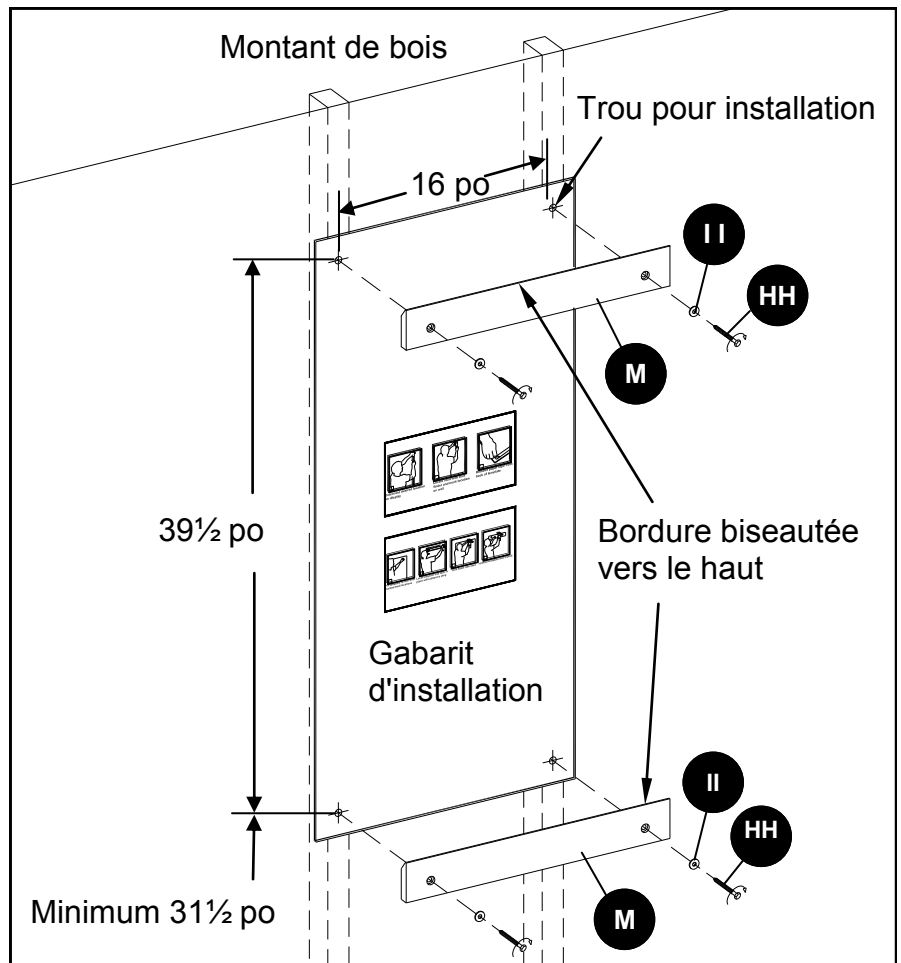

Étape 2

Installation au mur

NOTE : AU MOINS DEUX PERSONNES DOIVENT TRAVAILLER ENSEMBLE POUR INSTALLER L'UNITÉ AU MUR.

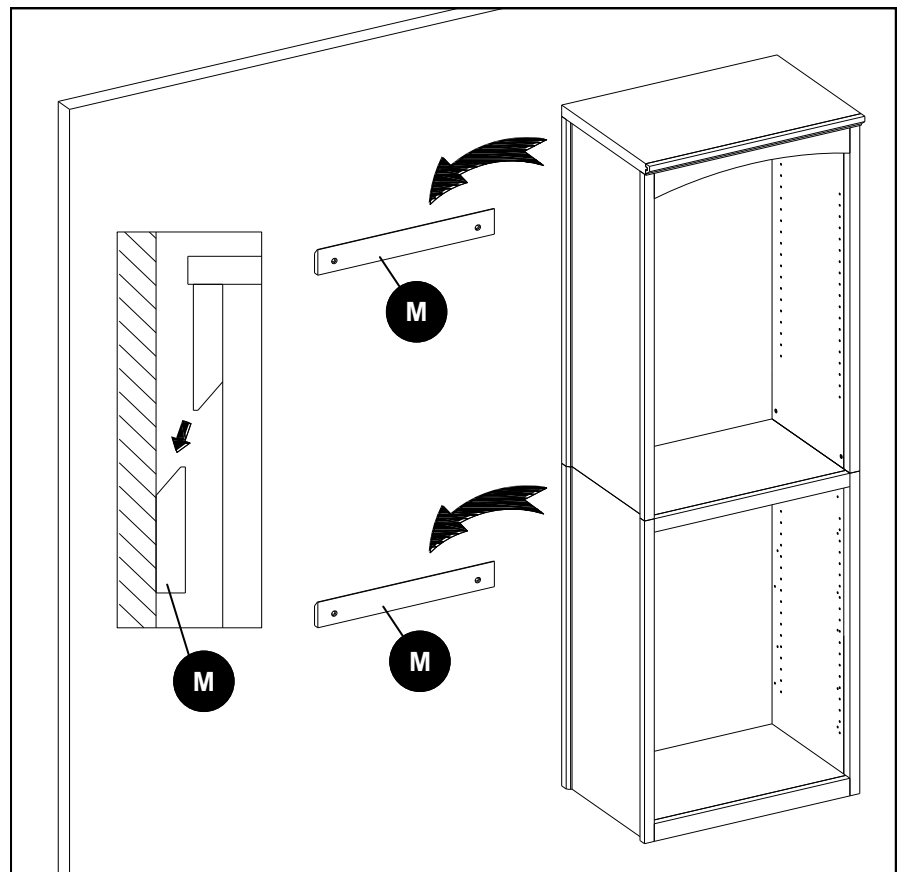

DIRECTIVES DE MONTAGE

Étape 1

Installation de la tablette

GG Taquet de tablette

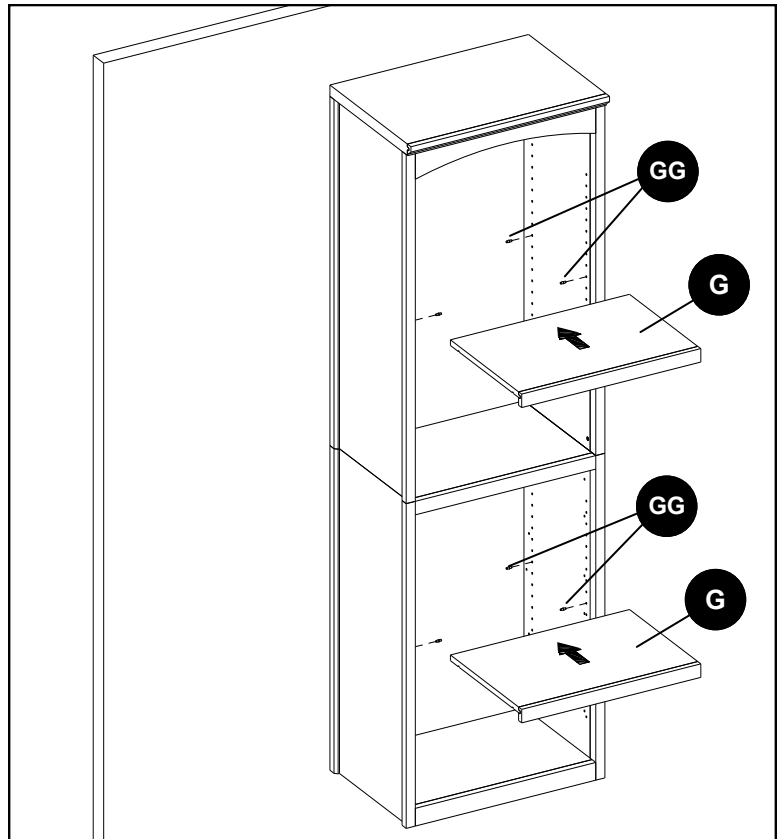
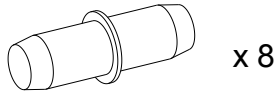

SOIN ET ENTRETIEN

- Vérifier régulièrement la position, l'intégrité et la solidité de tous les composants.
- Utiliser un linge doux et propre qui ne rayera pas la surface lors de l'époussetage.
- Ne jamais utiliser d'eau pour nettoyer le meuble car elle pourrait en endommager le fini.
- Essuyer avec un linge humide et un nettoyant doux. Sécher avec un linge propre.
- Dans le cas où le meuble serait taché ou autrement endommagé durant l'utilisation, il est recommandé de faire appel à un professionnel pour réparer le meuble.
- Garder le produit éloigné du soleil direct car il pourrait en endommager le fini.
- Il est préférable de garder le meuble dans un environnement climatique contrôlé. Les écarts extrêmes de température et d'humidité peuvent causer la décoloration, la torsion ou l'éclatement du bois.
- Un crayon à retouche (MM) est fourni (sauf pour l'article n° 0339209) pour réparer toute petite marque ou éraflure pouvant survenir durant le montage ou l'expédition.
- Si l'article n° 0339209 est endommagé et qu'une retouche est requise, appliquer un poli à bois de qualité à la surface endommagée. Le poli n'est pas inclus avec cet article.

DIAGNOSTIC

Pour toute question sur le produit, appeler le service à la clientèle au 1-866-439-9800, entre 8 h 00 et 20 h 00, Heure de l'Est, du lundi au vendredi.

PROBLÈME	CAUSE POSSIBLE	MESURE CORRECTIVE
La tour pour placard est inclinée	Les tasseaux pour fixation murale ne sont pas de niveau.	Réinstaller les tasseaux pour fixation murale et s'assurer qu'ils soient de niveau.
La tour pour placard ne peut être fixée au mur	L'emplacement des trous de montage est inadéquat.	Réinstaller les tasseaux pour fixation murale en s'assurant que l'espace entre deux tasseaux soit de 39 ½ po et que l'emplacement des deux trous de montage inférieurs soit à plus de 31 ½ po du plancher.

GARANTIE LIMITÉE À VIE

Ce produit (excluant les tablettes) est garanti à l'acheteur original. En cas de bris de cette unité dû à un défaut de fabrication ou des matériaux, le fabricant réparera ou remplacera l'article, à sa discrétion, sans frais. La garantie est nulle si le produit a été assemblé de manière incorrecte, a été mal utilisé, surchargé, modifié de quelque manière que ce soit ou endommagé suite à un accident. La présente garantie n'est pas transférable et ne couvre pas l'écaillage, les éraflures, la rouille, les marques ni les autres dommages aux surfaces de ce produit. La responsabilité du fabricant se limite à la réparation ou au remplacement de ce produit. Le fabricant n'est pas responsable des dommages accessoires ni indirects ni aux pertes résultant d'un défaut du produit.

La présente garantie tient lieu de toute autre garantie expresse. Certaines régions ne permettent pas l'exclusion ni la limite des dommages accessoires ou indirects et dans un tel cas, la limite précédente ne s'applique pas. La présente garantie vous accorde des droits légaux spécifiques et vous pourriez bénéficier d'autres droits qui varient d'une région à l'autre.

LISTE DES PIÈCES DE REMPLACEMENT

Pour obtenir des pièces de remplacement, appeler le service à la clientèle au 1-866-439-9800 entre 8 h 00 et 20 h 00, Heure de l'Est, du lundi au vendredi.

PIÈCE	DESCRIPTION	N° PIÈCE
A	Panneau gauche de huche	*WSWS-WU1C/W/P/S-1-HPL
B	Panneau droit de huche	*WSWS-WU1C/W/P/S-2-HPR
C	Panneau supérieur de huche	*WSWS-WU1C/W/P/S-3-HPT
D	Panneau arrière de huche	*WSWS-WU1C/W/P/S-4-HPB
E	Entretoise avant courbée	*WSWS-WU1C/W/P/S-5-FCS
F	Entretoise avant droite	*WSWS-WU1C/W/P/S-6-FCS
G	Tablette réglable	*WSWS-WU1C/W/P/S-7-AS
H	Panneau gauche de la base	*WSWS-WU1C/W/P/S-8-BPL
I	Panneau droit de la base	*WSWS-WU1C/W/P/S-9-BPR
J	Panneau supérieur de la base	*WSWS-WU1C/W/P/S-10-BPT
K	Panneau arrière de la base	*WSWS-WU1C/W/P/S-11-BPB
L	Panneau inférieur de la base	*WSWS-WU1C/W/P/S-12-BPB
M	Tasseau de suspension murale	*WSWS-WU1C/W/P/S-13-WHC
N	Gabarit d'installation	*WSWS-WU1C/W/P/S-26-IT
AA	Boulon ¼ x 1 ¼ po	*WSWS-WU1C/W/P/S-15-1-1/4B
BB	Rondelle frein	*WSWS-WU1C/W/P/S-16-LW
CC	Rondelle plate	*WSWS-WU1C/W/P/S-17-FW
DD	Grande came	*WSWS-WU1C/W/P/S-18-LCL
EE	Medium boulon à came	*WSWS-WU1C/W/P/S-19-MCB

PIÈCE	DESCRIPTION	N° PIÈCE
FF	Grand goujon de bois	*WSWS-WU1CW/P/S-20-LWD
GG	Taquet de tablette	*WSWS-WU1CW/P/S-21-SP
HH	Tire-fond M8 x 2 ½ po	*WSWS-WU1CW/P/S-22-2-1/2LB
II	Grande rondelle plate	*WSWS-WU1CW/P/S-23-LFW
JJ	Grand boulon à came	*WSWS-WU1CW/P/S-26-LCB
KK	Écrou cylindrique	*WSWS-WU1CW/P/S-27-BN
LL	Clé hexagonale M4	*WSWS-WU1CW/P/S-24-M4AW
MM	Crayon à retouche	*WSWS-WU1CW/S-25-TUP
	Quincaillerie complète	*WSWS-WU1CW/P/S-14-CH

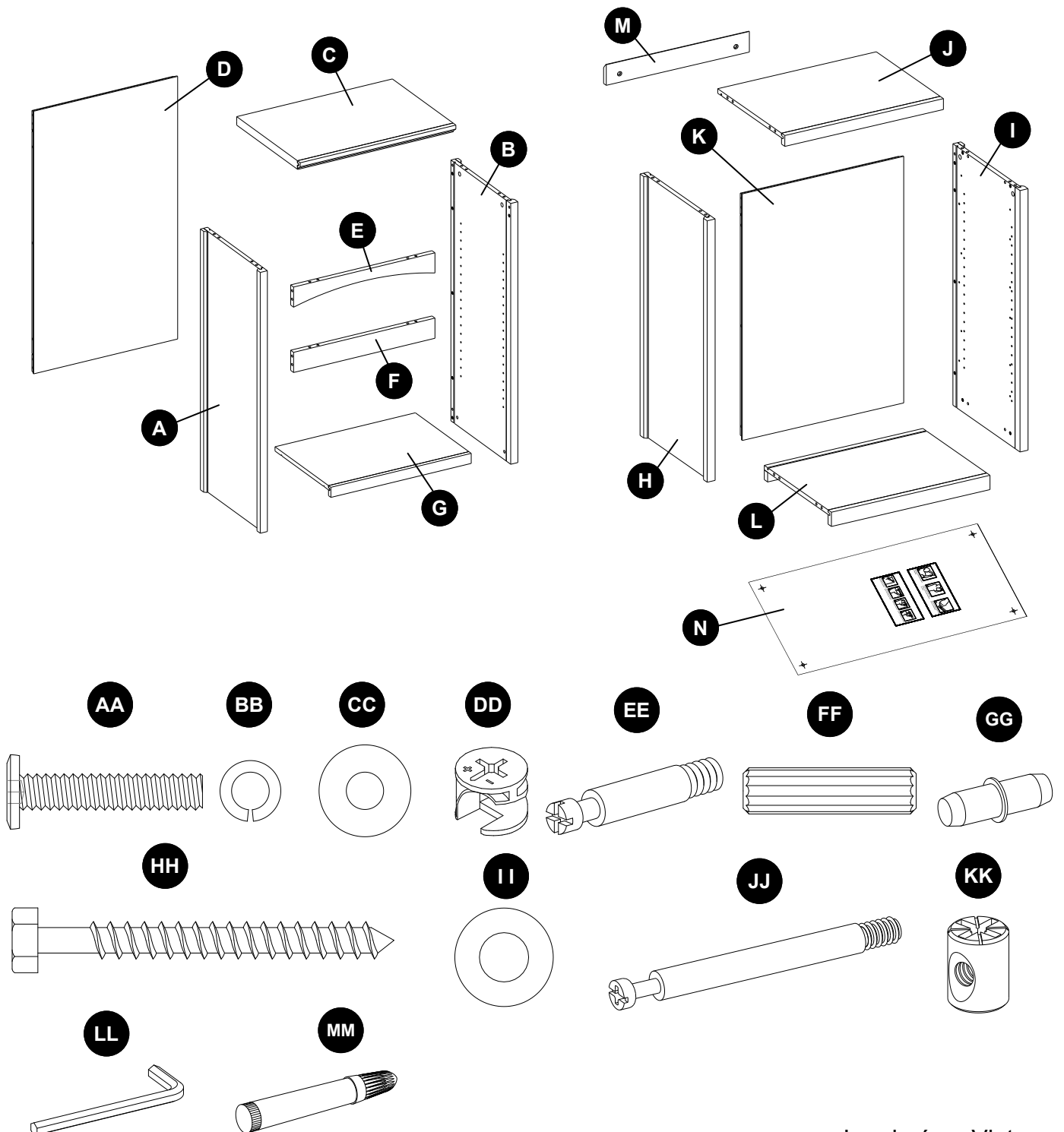



ARTÍCULO #0339207, #0339208, #0339209, #0339210

TORRE DE MADERA DE PRIMERA CALIDAD

MODELO #WSWS-WU1C, #WSWS-WU1W
#WSWS-WU1P, #WSWS-WU1S

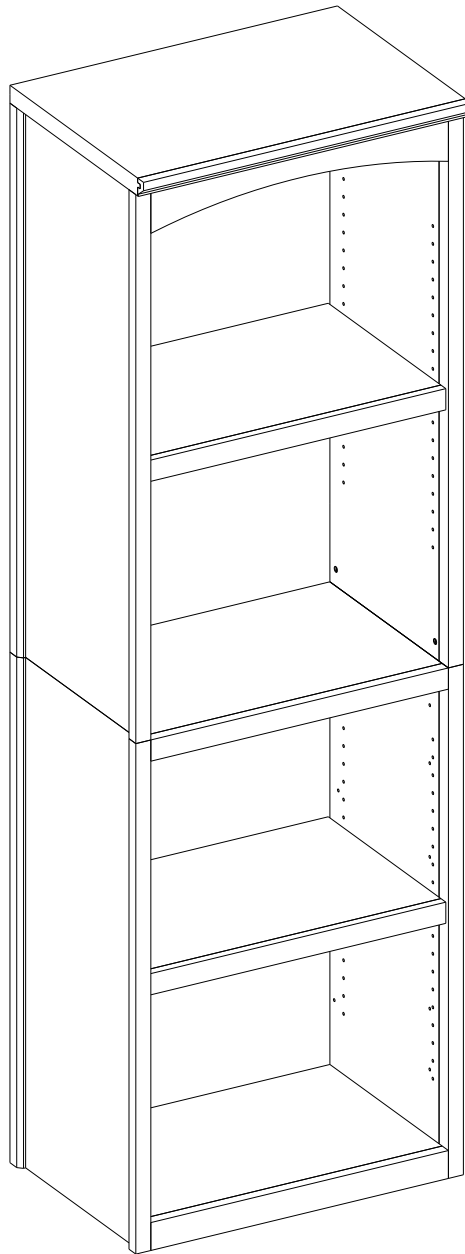

ADJUNTE SU RECIBO AQUI

Número de Serie _____

Fecha de Compra _____



Preguntas, problemas, le faltan piezas? Antes de volver a la tienda, llame a nuestro departamento de servicio al cliente al 1-866-439-9800, de 8 am - 8 pm, Horario del Este, de Lunes - Viernes.

TABLA DE CONTENIDO

Operación del sistema fijador de levas.....	32
Contenidos del Empaque.....	33
Contenidos de Artículos de Ferretería.....	34
Información de Seguridad.....	35
Preparación	35
Instrucciones de Ensamble.....	36
Cuidado y Mantenimiento.....	43
Solución de problemas.....	43
Garantía.....	44
Lista de Partes de Repuesto.....	44

OPERACIÓN DEL SISTEMA FIJADOR DE LEVAS

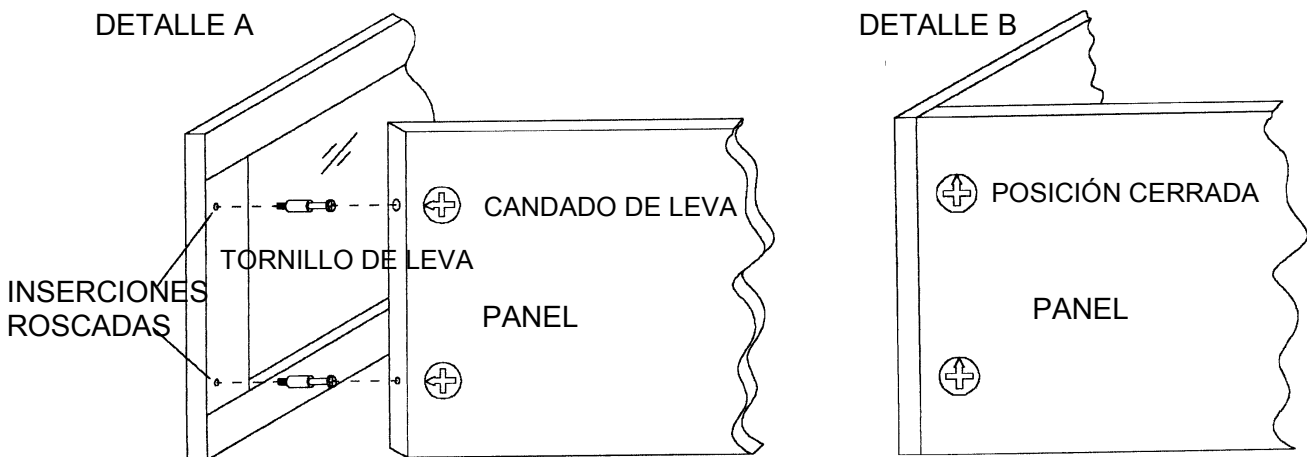

1. Atornille el Tornillo de Leva dentro de la inserción roscada en el panel.
2. Introduzca el Candado de Leva dentro del agujero pretaladrado en el panel.
3. Cerciérese que el Candado de Leva esté apuntando hacia el Tornillo de Leva.
4. Conecte ambos paneles juntos; cerciorandose que los Tornillos de Leva vayan en los agujeros pretaladrados con el Candado de Leva.
5. Una vez que el Tornillo de Leva esté conectado dentro del Candado de Leva, tome un destornillador Phillips y apriete el Candado de Leva hacia la derecha.

CONTENIDOS DE EMPAQUE

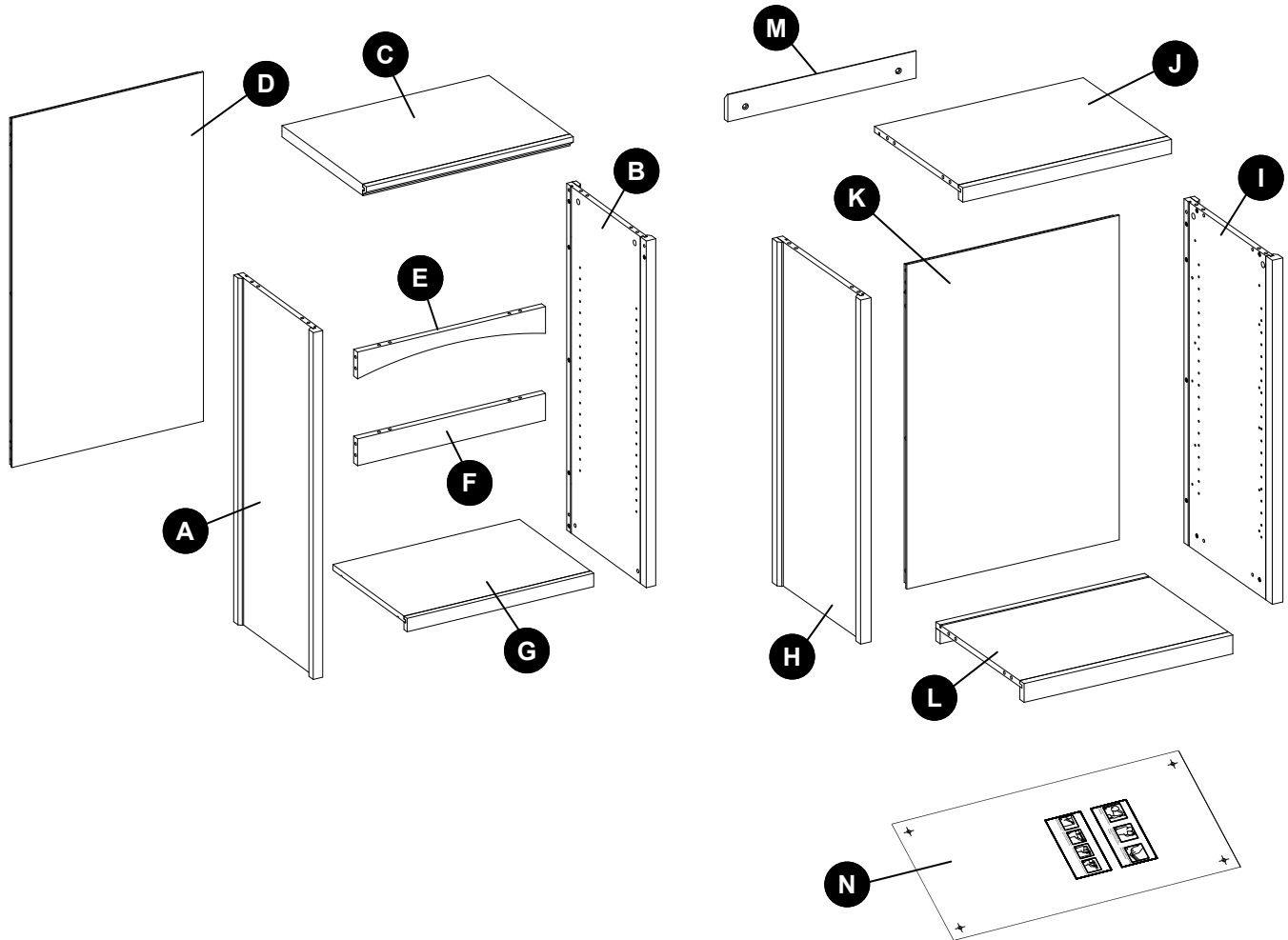

PARTE	DESCRIPCIÓN	CANT.
A	Panel Izquierdo de Caja	1
B	Panel Derecho de Caja	1
C	Panel Superior de Caja	1
D	Panel Posterior de Caja	1
E	Restirador Curvo Frontal	1
F	Restirador Recto Frontal	1
G	Repisa Ajustable	2

PART	DESCRIPCIÓN	CANT.
H	Panel Izquierdo de Base	1
I	Panel Derecho de Base	1
J	Panel Superior de la Base	1
K	Panel Posterior de la Base	1
L	Panel Inferior de la Base	1
M	Cuña para Colgar en	2
N	Patrón de Instalación	1

CONTENIDOS DE ARTÍCULOS DE FERRETERÍA

AA

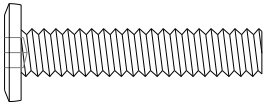

Tornillo de 1/4 x 1-1/4 pulg (3,2 cm)

Cant. 12

BB



Arandela de Presión

Cant. 12

CC

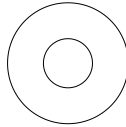

Arandela plana

Cant. 12

DD

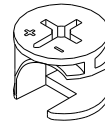

Candado de Leva Grande

Cant. 34

EE

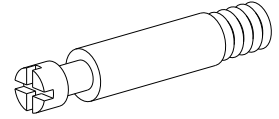

Tornillo de Leva Medio

Cant. 30

FF

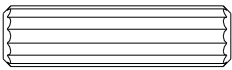

Clavija de Madera Grande

Cant. 34

GG

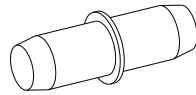

Pasador de Repisa

Cant. 8

HH

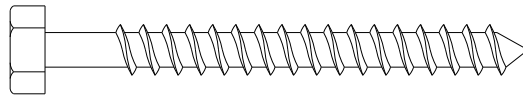

Tornillo con Cabeza Hexagonal de 8 mm x 2-1/2 pulgada (6,35 cm)

Cant. 4

II

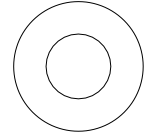

Arandela Plana Grande

Cant. 4

JJ

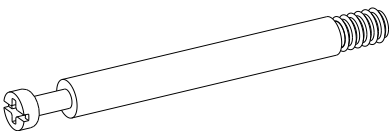

Tornillo de Leva Grande

Cant. 4

KK

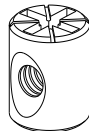

Tuerca Barril

Qty. 4

LL

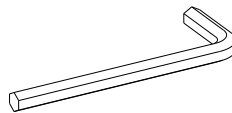

Llave Allen de 4 mm

Cant. 1

MM

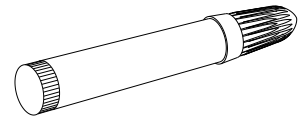

Plumón para Retoques

Cant. 1
(no se incluye para el Artículo #0339209)



INFORMACIÓN DE SEGURIDAD

Por favor lea y entienda este manual completamente antes de intentar el ensamble, operar o instalar el producto.

1. No permita que los niños se suban o jueguen en o alrededor de este product.
2. Utilice esta unidad para la que ha sido concebido. No utilice las repisas como escalera de mano.
3. Para evitar daños, monte el producto en una superficie firme, nivelada y protectora.
4. Dos o más personas deben trabajar juntos para instalar la unidad en la pared.
5. Asegúrese de que todos los pernos y tornillos estén bien apretados antes de que la unidad sea utilizada.
6. Revise los pernos/tornillos periódicamente y apriete en caso de ser necesario.

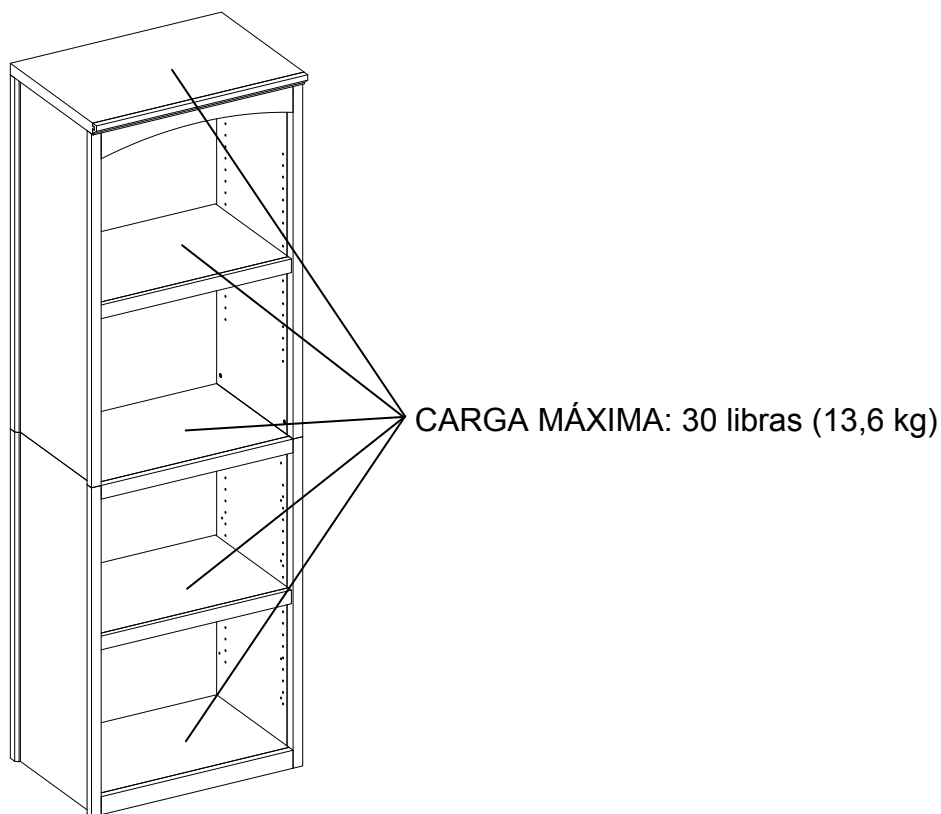

! ADVERTENCIA

ESTA UNIDAD ESTA INTENCIONADA PARA USO SOLAMENTE CON LOS PESOS MÁXIMOS INDICADOS. EL USO DE PRODUCTOS MÁS PESADOS QUE LOS INDICADOS PUEDE RESULTAR EN INESTABILIDAD CAUSANDO POSIBLES LESIONES. DISTRIBUYA EL PESO UNIFORMEMENTE.

PREPARACIÓN

Antes de comenzar la instalación del producto, asegúrese de que todas las partes estén presentes. Compare las piezas con la lista de contenidos y lista de artículos de ferretería contenido. Si alguna pieza falta o está dañada, no trate de armar, instalar o utilizar el producto. Póngase en contacto con departamento de servicio al cliente para piezas de repuesto.

Tiempo estimado de ensamble: 60 minutos

Herramientas Requeridas para el Ensamble (no incluidas): Destornillador Phillips, Taladro Eléctrico, Broca de 3/16 Pulgadas (4,8 mm), Broca de 3/8 Pulgadas (9,5 mm), Broca de 1/2 Pulgadas (12,7 mm), Nivelador, Llave de Dado, Localizador de Viga, Lápiz Marcador, Cinta para Medir, Escalera y Martillo.

Paso 1

Ensamble de la Base

EE Tornillo de Leva Medio

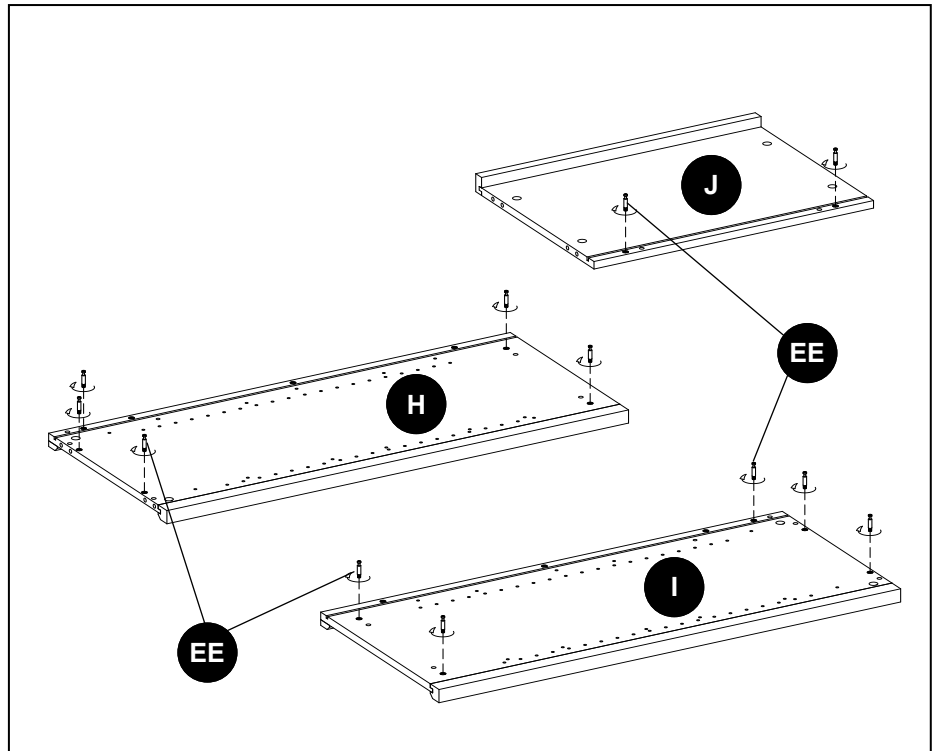
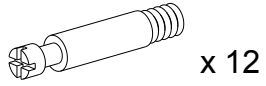

Paso 2

Ensamble de la Base

DD Candado de Leva Grande



FF Clavija de Madera Grande

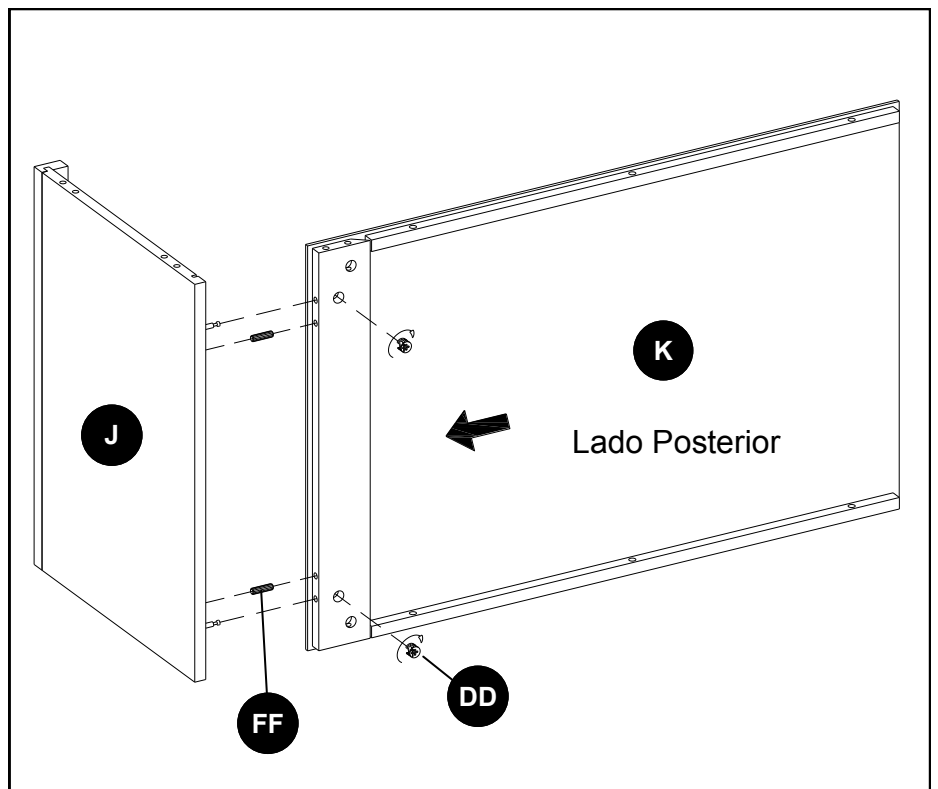
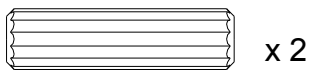

Paso 3

Ensamble de la Base

DD Candado de Leva Grande



FF Clavija de Madera Grande

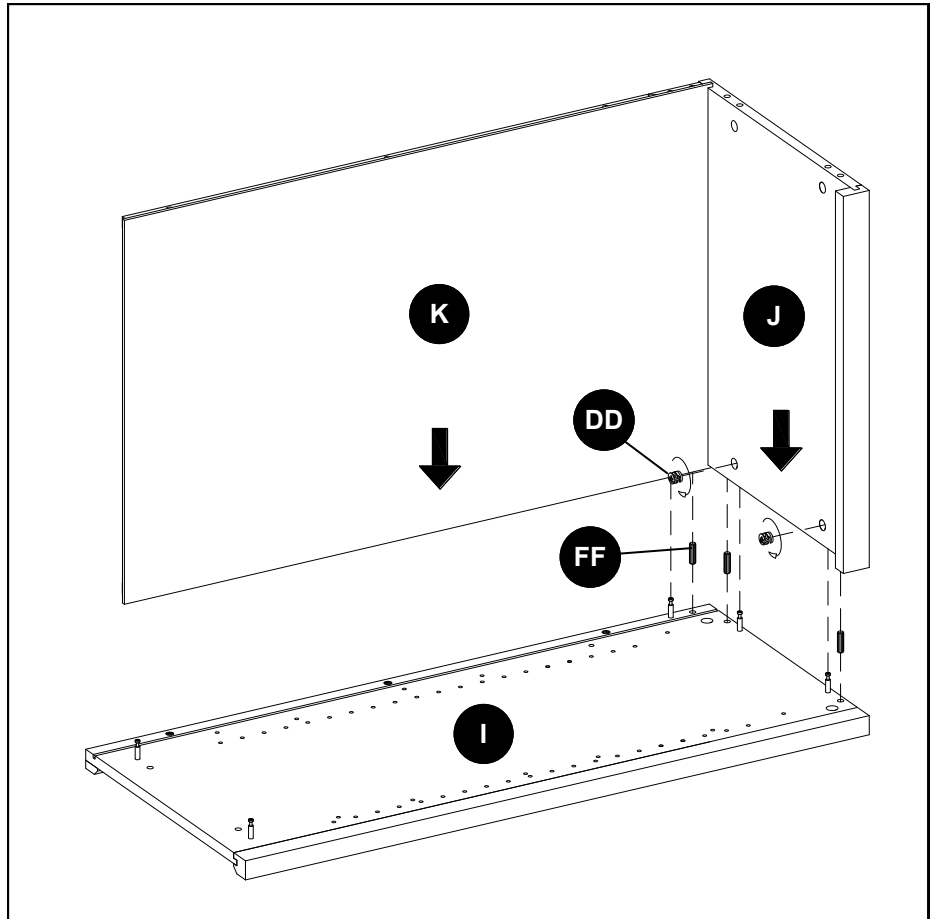
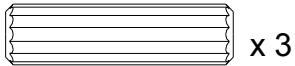

Paso 4

Ensamble de la Base

AA Tornillo de 1/4 x 1-1/4 pulg (3,2 cm)

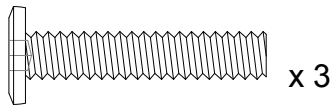

BB Arandela de Presión



CC Arandela Plana

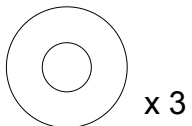

DD Candado de Leva Grande

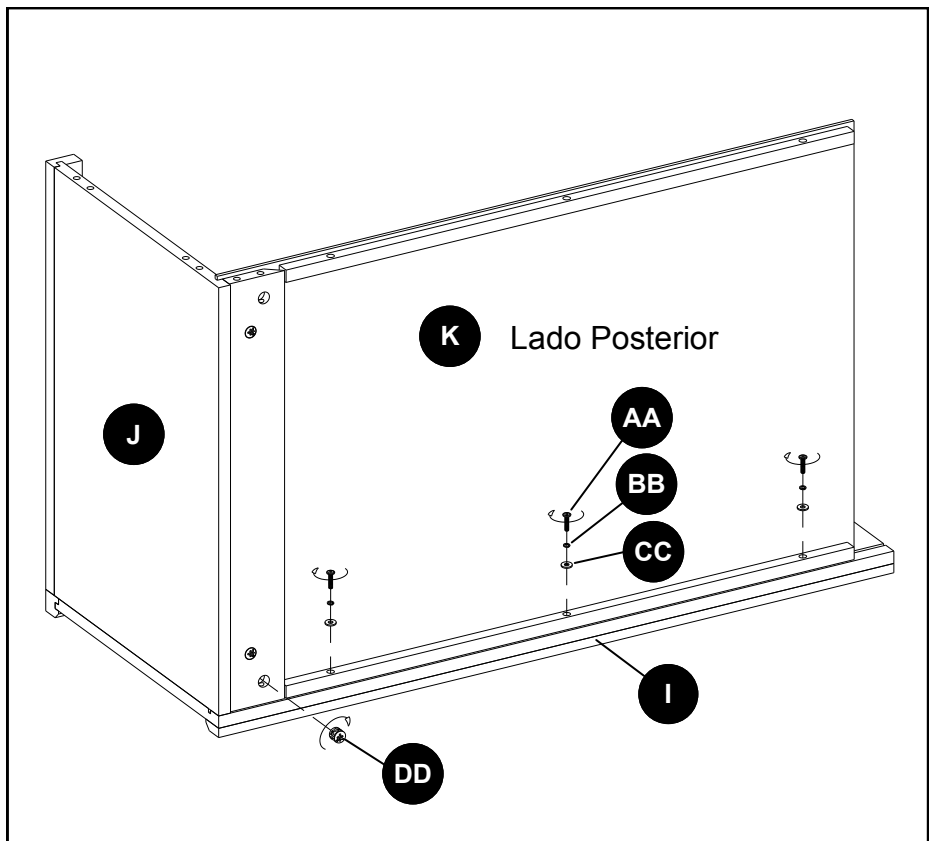
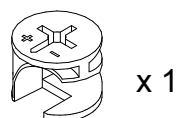

Paso 5

Ensamble de la Base

DD Candado de Leva Grande



FF Clavija de Madera Grande

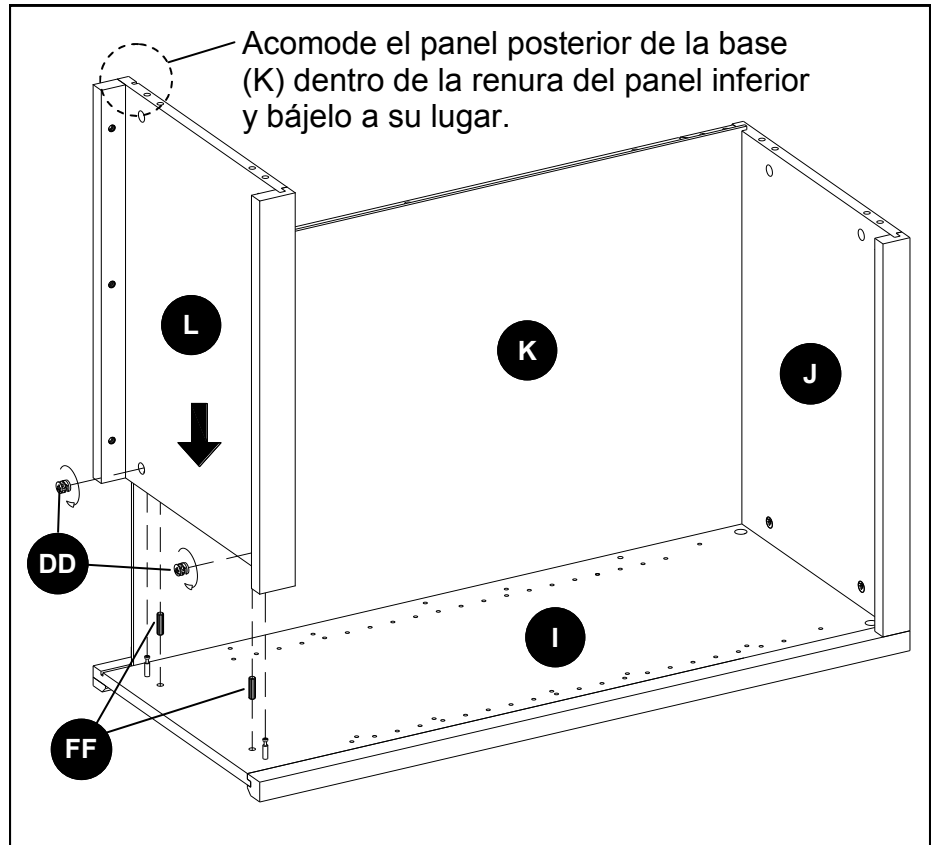
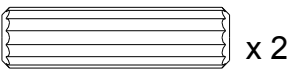

Paso 6

Ensamble de la Base

DD Candado de Leva Grande



FF Clavija de Madera Grande

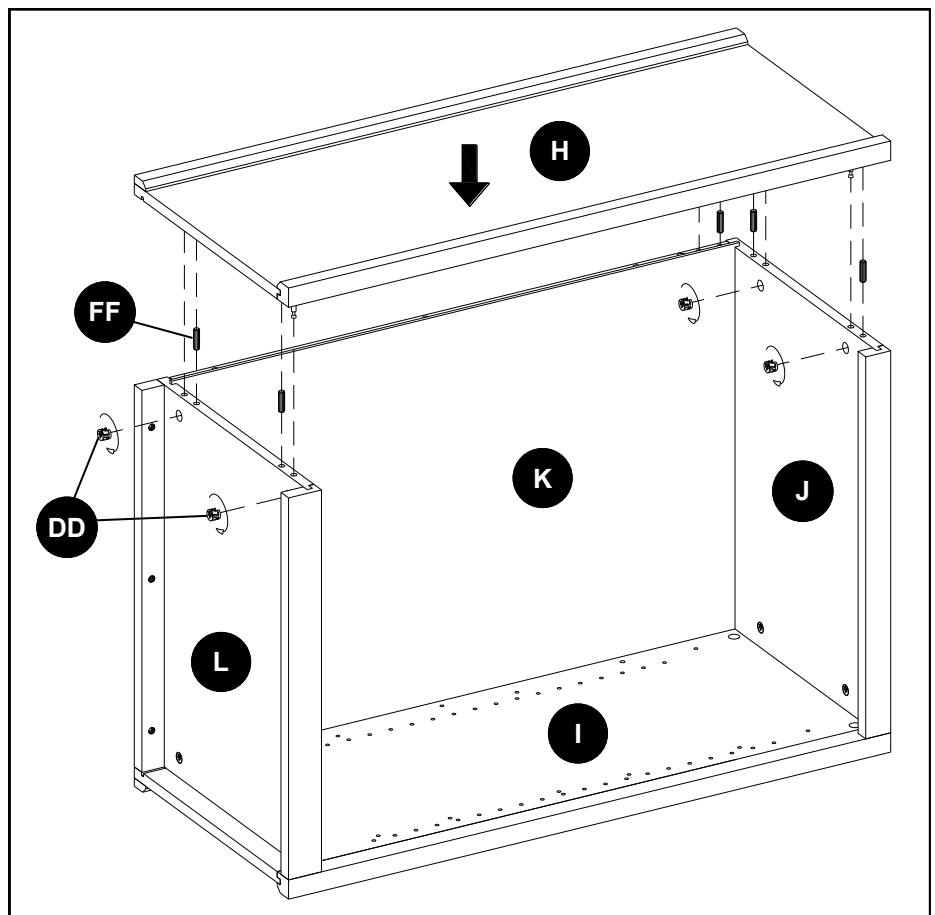
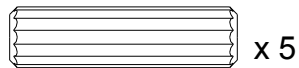

Paso 7

Ensamble de la Base

- AA** Tornillo de 1/4 x 1-1/4 pulg (3,2 cm)

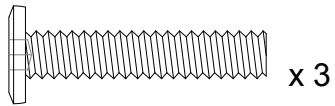

- BB** Arandela de Presión



- CC** Arandela Plana

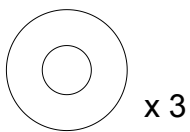

- DD** Candado de Leva Grande

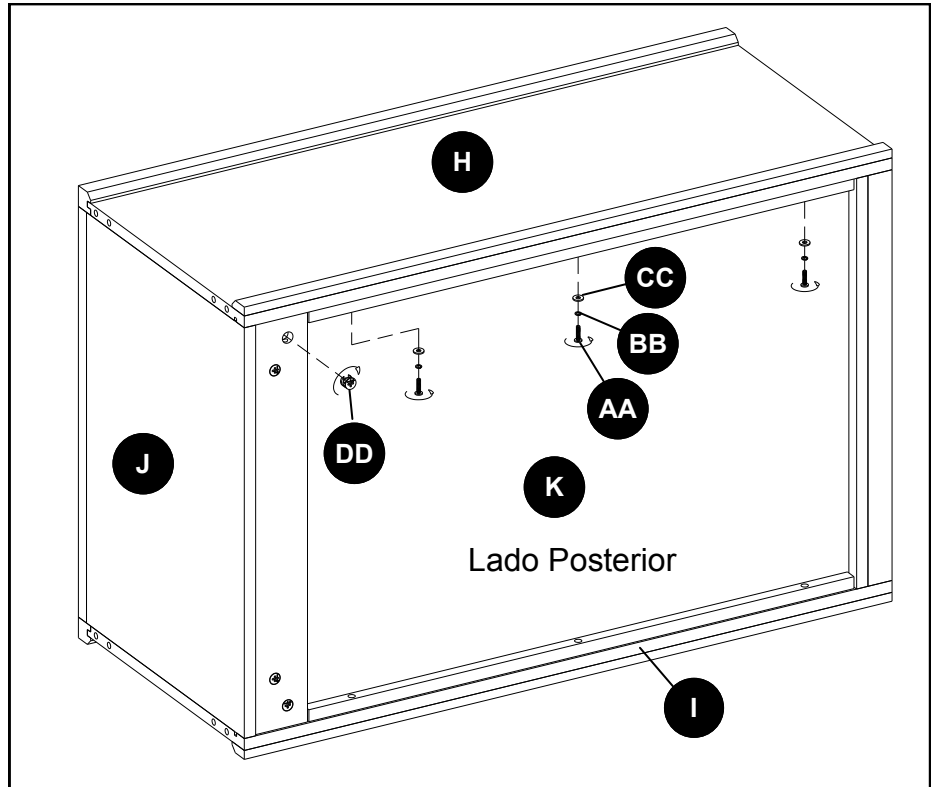
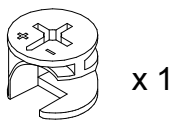

Paso 1

Ensamble del Compartimiento

- EE** Tornillo de Leva Medio

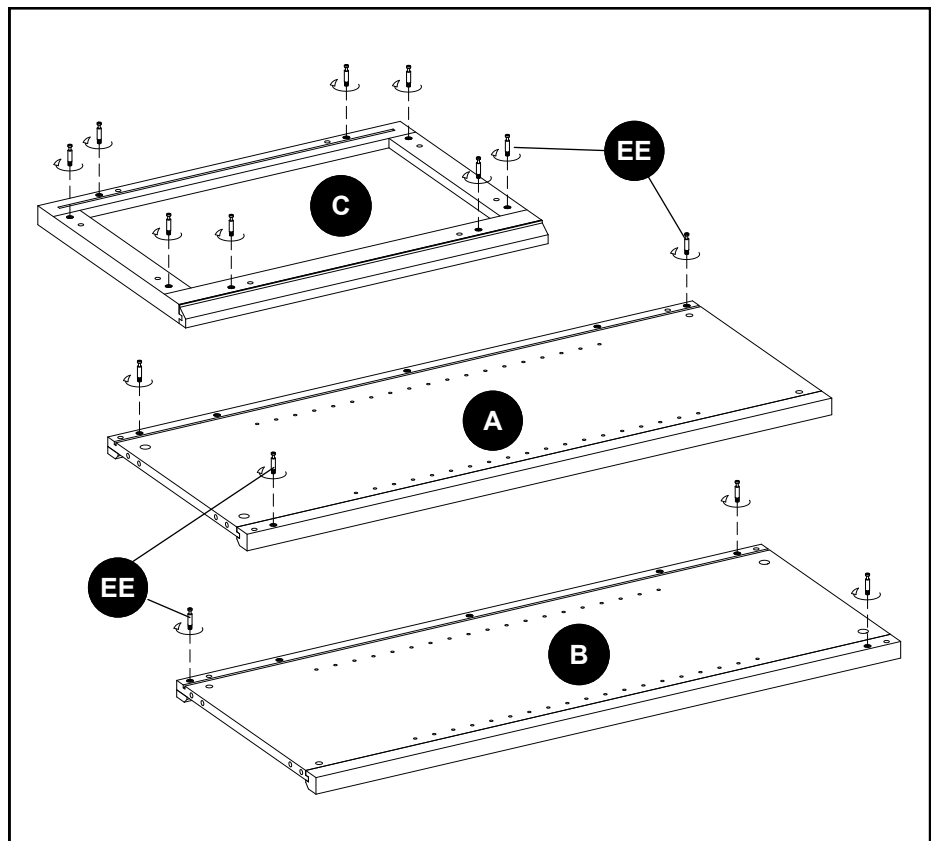
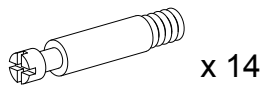

Paso 2
Ensamble del
Compartimento

AA Tornillo de 1/4 x 1-1/4 pulg (3,2 cm)

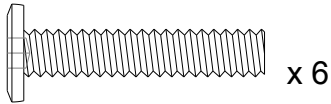

BB Arandela de Presión



CC Arandela Plana

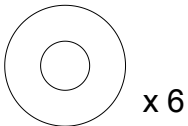

DD Candado de Leva Grande



FF Clavija de Madera Grande

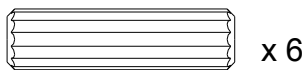

Choisir l'entretoise avant courbée (E) ou l'entretoise avant droite (F) selon l'aspect de votre placard et assembler selon les directives plus bas.

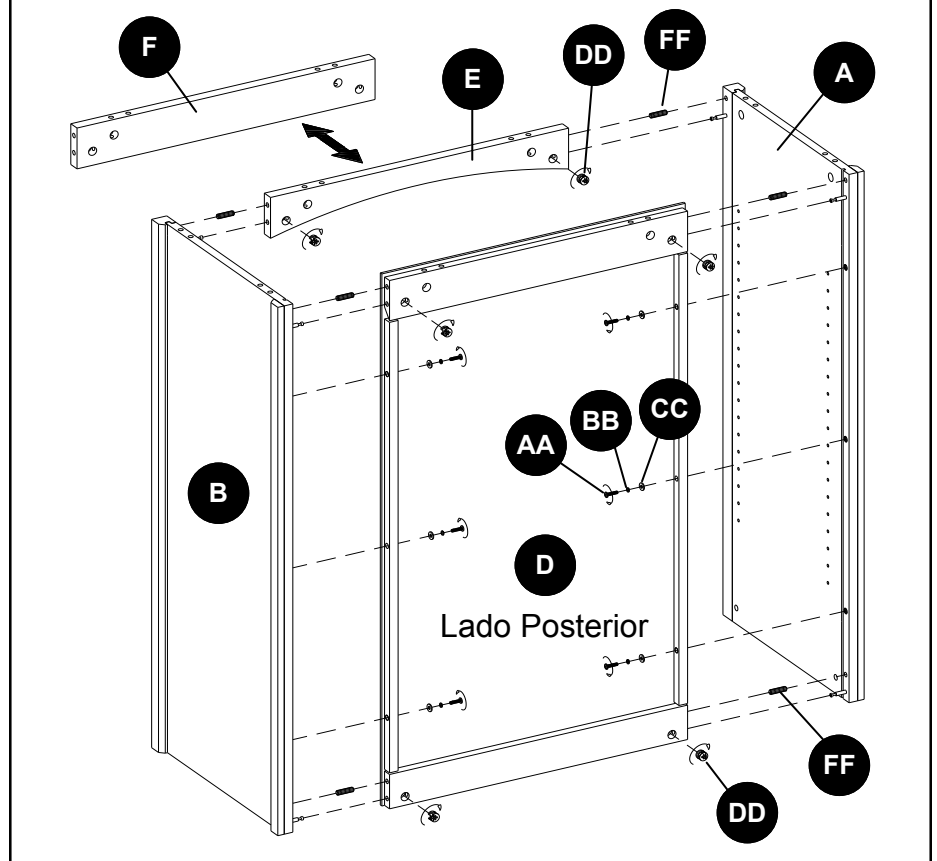

Paso 3
Ensamble del
Compartimento

DD Candado de Leva Grande



FF Clavija de Madera Grande

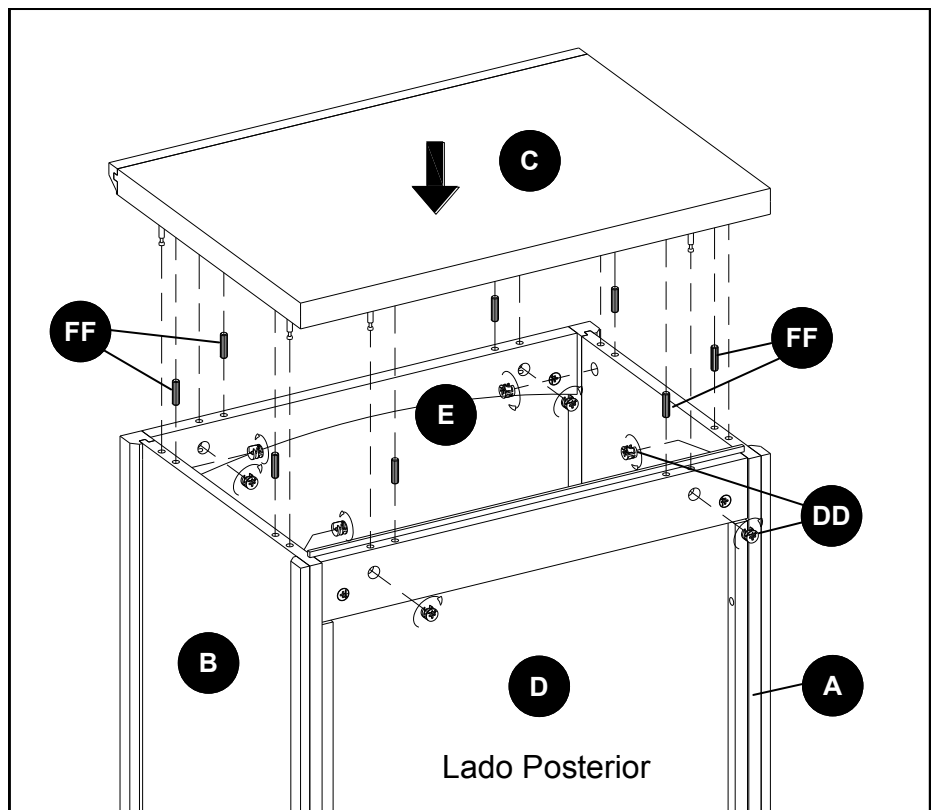
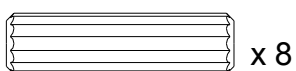

Paso 4
Ensamble del
Compartimiento

JJ Tornillo de Leva Grande

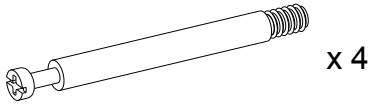

KK Tuerca Barril

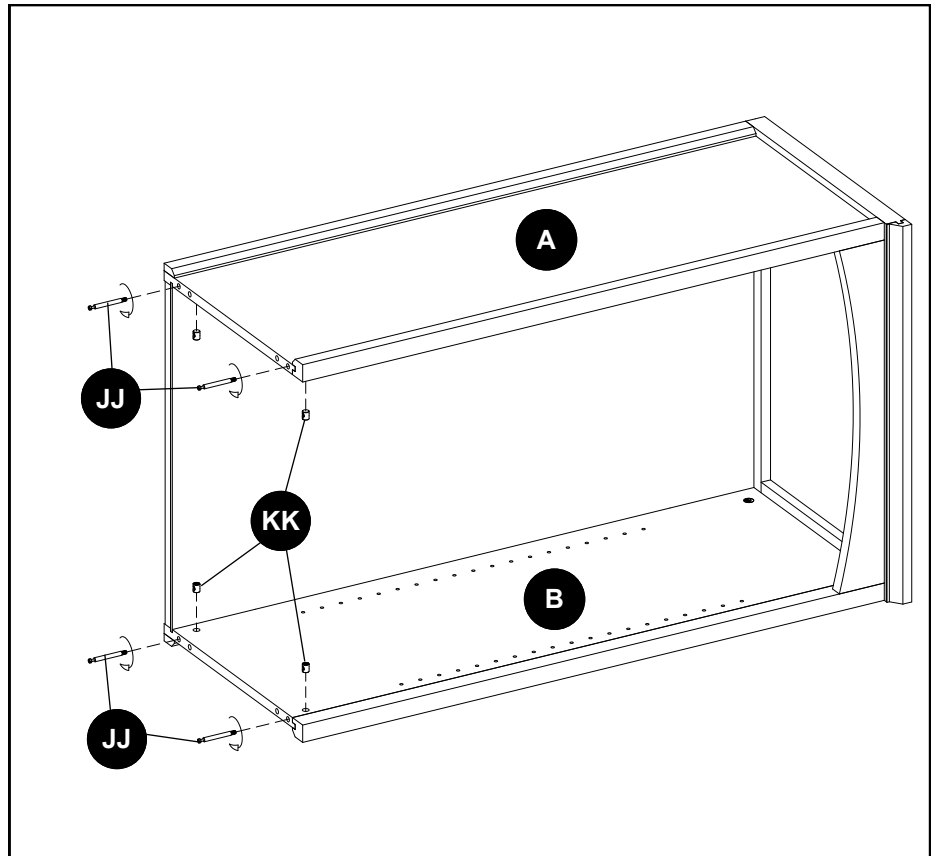
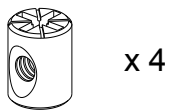

Paso 5
Hutch assembly

DD Candado de Leva Grande



FF Clavija de Madera Grande

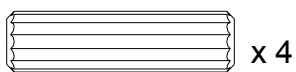

NOTA: Pida la ayuda de un amigo para este paso.

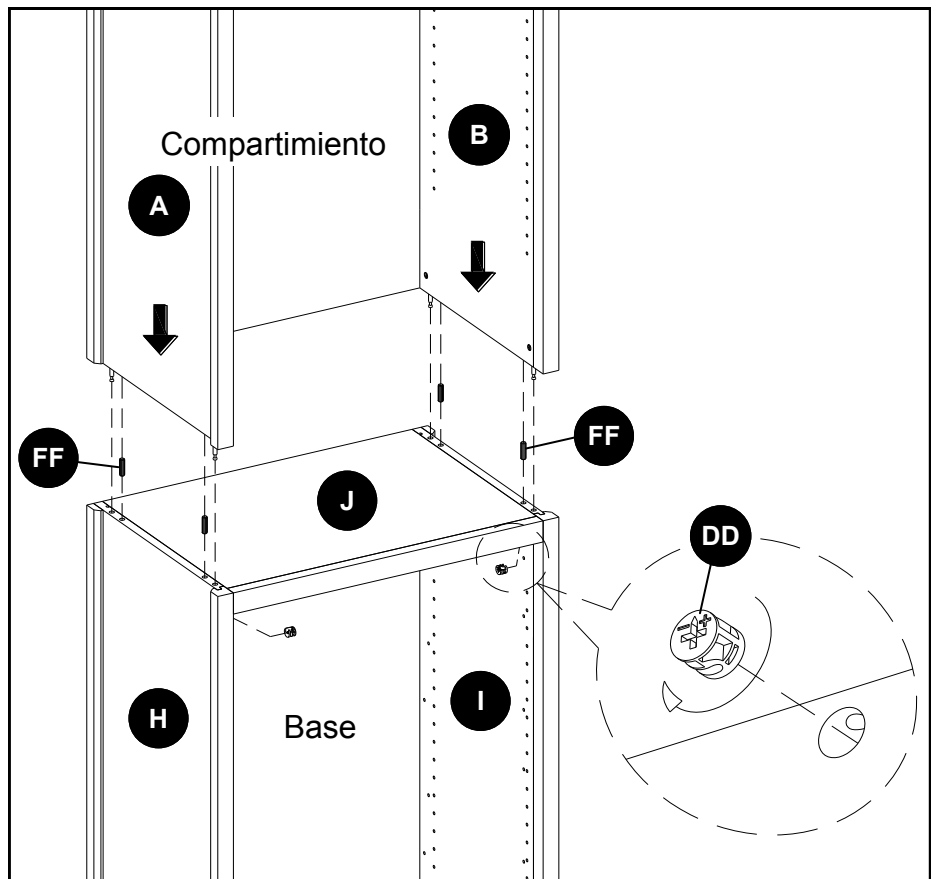

INSTRUCCIONES DE ENSAMBLE

Paso 1

Instalación de Colgar en Pared

HH Tornillo con Cabeza Hexagonal de 8 mm x 2 ½ pulg (6,35 cm)

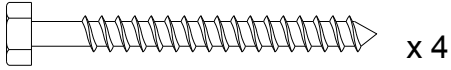

II Arandela Plana Grande

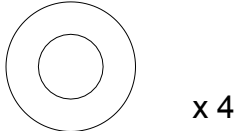

Coloque el patrón de instalación proporcionado (W) en la ubicación deseada y siga cuidadosamente las instrucciones del patrón para marcar los agujeros de la instalación. Asegúrese de que la ubicación de los dos orificios en la parte inferior de la instalación de más de 31 ½ pulgadas (80 cm) del piso. Taladre agujeros de 2 ½ pulgadas (6,35 cm) de profundidad con una broca de 3/16 pulgadas (4,8 mm) en el lugar marcado.

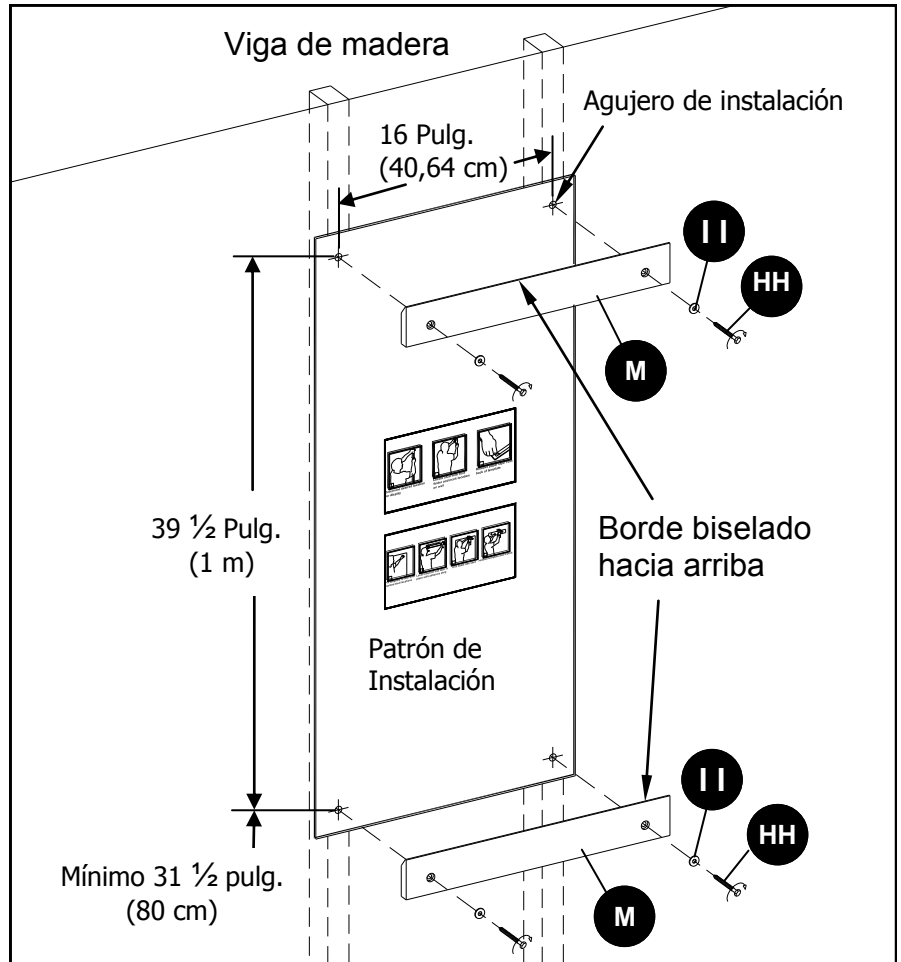

Étape 2

Instalación de Colgar en Pared

NOTA: DOS A MÁS PERSONAS DEBEN DE TRABAJAR JUNTAS PARA INSTALAR LA UNIDAD A LA PARED.

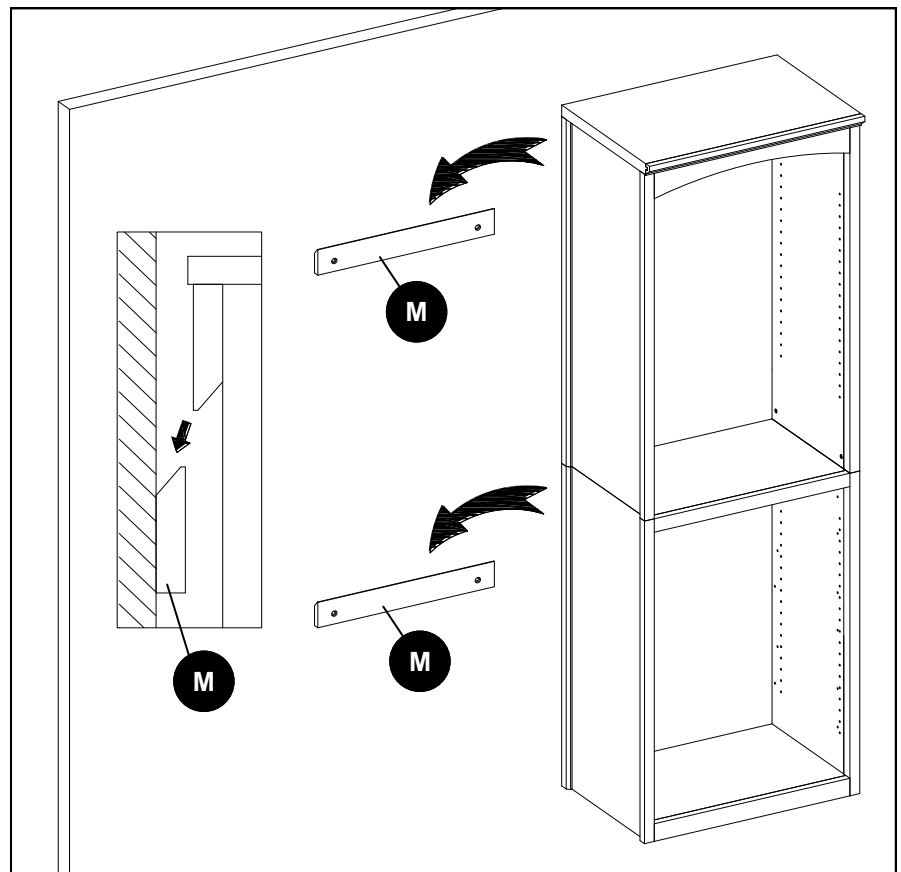

INSTRUCCIONES DE ENSAMBLE

Paso 1

Instalación de la Repisa Ajustable

GG Pasador de Repisa

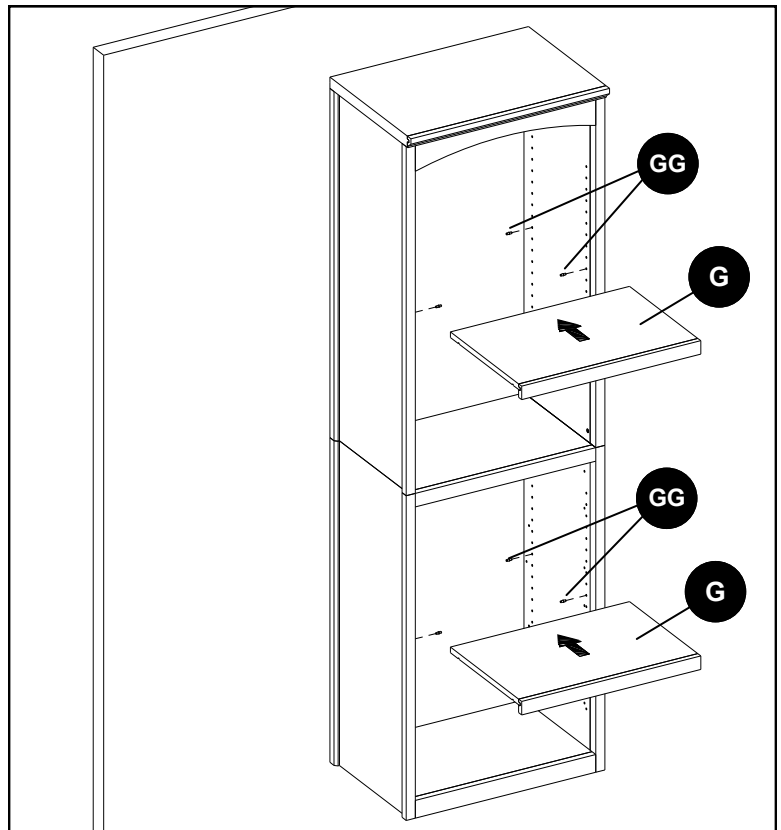
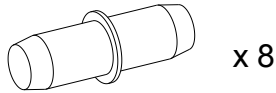

CUIDADO Y MANTENIMIENTO

- Revise periódicamente para asegurarse de que todos los componentes están bien posicionados, libre de daños y bien conectados.
- Utilice un paño suave y limpio para no rayar la superficie al desempolvar.
- Nunca use agua para limpiar sus muebles, ya que puede causar daño al acabado.
- Limpie con un paño húmedo, limpio y con un limpiador suave. Seque con un paño limpio.
- En caso de que sus muebles se mancha o se ha dañado durante el uso, se recomienda que llame a un profesional para reparar los muebles.
- Mantenga los muebles lejos de la luz solar directa, ya que pueden dañar el acabado.
- Es mejor mantener los muebles en un ambiente de clima controlado. temperaturas extremas y los cambios de humedad pueden causar la decoloración, deformación, la reducción y separación de la madera.
- Plumón de retoque (MM) se ha proporcionado (excepto en el artículo # 0339209) para reparar cualquier golpes o rayadura pequeña que pueden ocurrir durante el montaje o el envío.
- Si el artículo # 0339209 está dañado y retoque es necesario por favor aplique un esmalte de madera de calidad a la superficie dañada. El pulidor no se incluye con este artículo.

SOLUCIÓN DE PROBLEMAS

Si tiene preguntas acerca del producto, por favor llame a nuestro departamento de servicio al cliente al 1-866-439-9800, de 8 am - 8 pm, Horario del Este, de Lunes - Viernes.

PROBLEMA	POSIBLE CAUSA	ACCIÓN CORRECTIVA
La torre para armario está inclinada	Las cuñas para pared no están niveladas.	Vuelva a instalar las cuñas para colgar en pared y asegurar que estén niveladas.
La torre para armario no puede colgar de la pared	Las ubicaciones de los agujeros de montaje no están correctos.	Vuelva a instalar las cuñas para colgar en pared; asegúrese de que el espacio entre las dos cuñas para colgar en pared sea de 39 ½ pulgadas (1 m) y que la ubicación de los dos agujeros de montaje sea mas de 31 ½ pulgadas (80 cm) del piso.

GARANTÍA LIMITADA DE POR VIDA

Este producto (con exclusión de las repisas) está garantizado para el comprador original. Si hay una falla en esta unidad debido a defectos en materiales o mano de obra, el fabricante reparará o reemplazará este artículo a nuestra discreción, sin cargo. La garantía se anula si el producto ha sido montado de forma incorrecta, mal uso, abuso por sobrecarga, alterado en cualquier forma o dañados debido a un accidente. Esta garantía no es transferible y no cubre astilladuras, descascaraduras, rayaduras, corrosión, abolladuras u otros daños a la superficie de este producto. La responsabilidad del fabricante se limita a la reparación o reemplazo de este producto. El fabricante no se hace responsable por daños indirectos, incidentales, o de otro tipo o pérdidas resultantes de la falla del producto.

Esta garantía está en lugar de cualquier otra garantía expresa. Algunos estados no permiten la exclusión o limitación de daños incidentales o consecuentes, por lo que la limitación anterior puede no aplicarse a usted. Esta garantía le otorga derechos legales específicos y usted puede tener otros derechos que varían de estado a estado.

LISTA DE PARTES DE REPUESTO

Para piezas de repuesto, llame a nuestro departamento de servicio al cliente al 1-866-439-9800, de 8 am - 8 pm, horario del Este, de Lunes - Viernes.

PARTE	DESCRIPCIÓN	# DE PARTE
A	Panel Izquierdo del Compartimiento	*WSWS-WU1C/W/P/S-1-HPL
B	Panel Derecho del Compartimiento	*WSWS-WU1C/W/P/S-2-HPR
C	Panel Superior del Compartimiento	*WSWS-WU1C/W/P/S-3-HPT
D	Panel Posterior del Compartimiento	*WSWS-WU1C/W/P/S-4-HPB
E	Restirador Curvo Frontal	*WSWS-WU1C/W/P/S-5-FCS
F	Restirador Recto Frontal	*WSWS-WU1C/W/P/S-6-FCS
G	Repisa Ajustable	*WSWS-WU1C/W/P/S-7-AS
H	Panel Izquierdo de Base	*WSWS-WU1C/W/P/S-8-BPL
I	Panel Derecho de Base	*WSWS-WU1C/W/P/S-9-BPR
J	Panel Superior de la Base	*WSWS-WU1C/W/P/S-10-BPT
K	Panel Posterior de la Base	*WSWS-WU1C/W/P/S-11-BPB
L	Panel Inferior de la Base	*WSWS-WU1C/W/P/S-12-BPB
M	Cuña para Colgar en Pared	*WSWS-WU1C/W/P/S-13-WHC
N	Patrón de Instalación	*WSWS-WU1C/W/P/S-26-IT
AA	Tornillo de 1/4 x 1-1/4 pulg (3,2 cm)	*WSWS-WU1C/W/P/S-15-1-1/4B
BB	Arandela de Presión	*WSWS-WU1C/W/P/S-16-LW
CC	Arandela Plana	*WSWS-WU1C/W/P/S-17-FW
DD	Candado de Leva Grande	*WSWS-WU1C/W/P/S-18-LCL
EE	Tornillo de Leva Medio	*WSWS-WU1C/W/P/S-19-MCB

PARTE	DESCRIPCIÓN	# DE PARTE
FF	Clavija de Madera Grande	*WSWS-WU1CW/P/S-20-LWD
GG	Pasador de Repisa	*WSWS-WU1CW/P/S-21-SP
HH	Tornillo de 8 mm x 2-1/2 pulg (6,35 cm)	*WSWS-WU1CW/P/S-22-2-1/2LB
II	Arandela Plana Grande	*WSWS-WU1CW/P/S-23-LFW
JJ	Tornillo de Leva Grande	*WSWS-WU1CW/P/S-26-LCB
KK	Tuerca Barril	*WSWS-WU1CW/P/S-27-BN
LL	Llave Allen de 4 mm	*WSWS-WU1CW/P/S-24-M4AW
MM	Plumón para Retoques	*WSWS-WU1CW/S-25-TUP
	Artículos de Ferretería Completos	*WSWS-WU1CW/P/S-14-CH

