

ATTACHED SINGLE HEADER PERGOLA ASSEMBLY INSTRUCTIONS

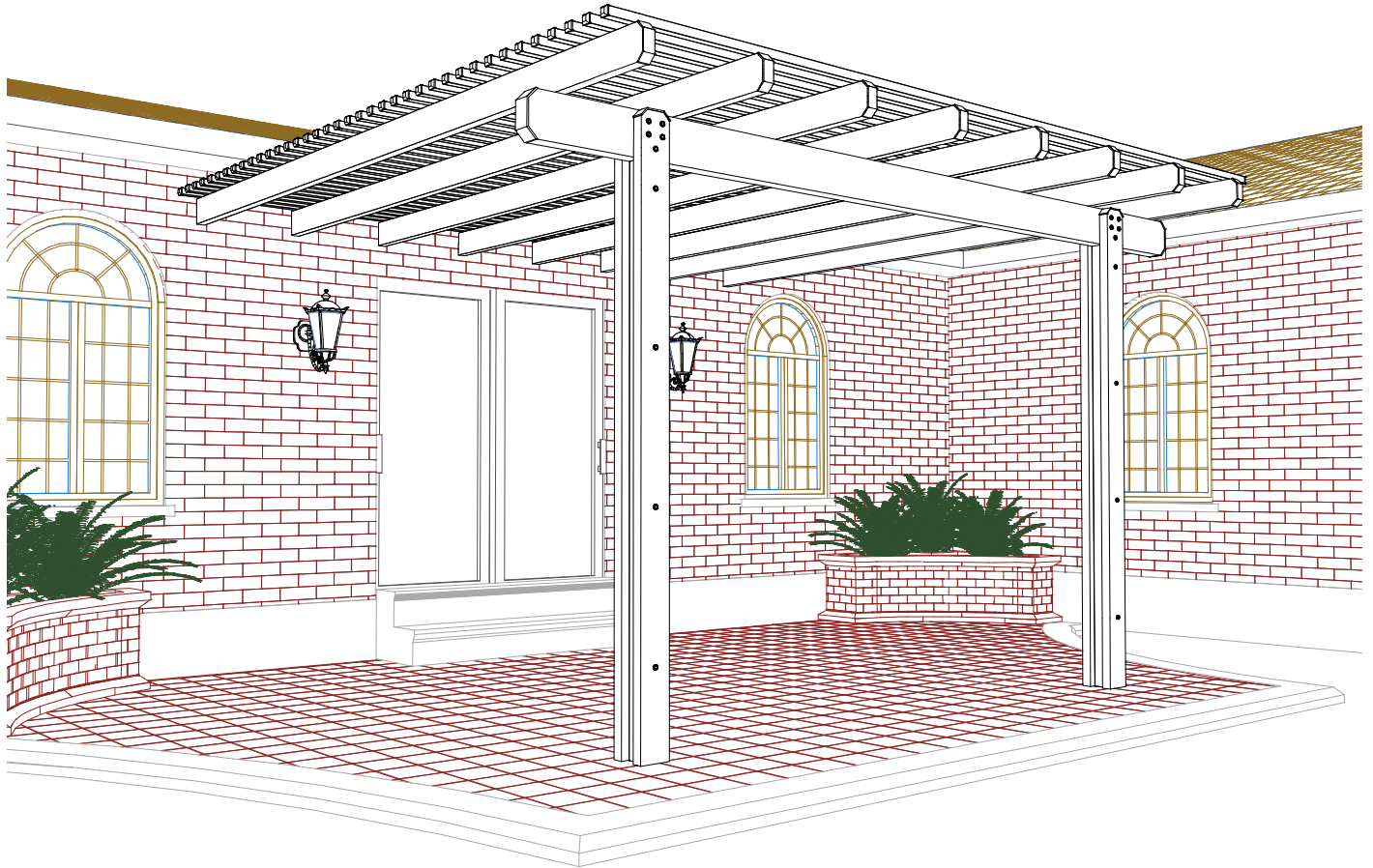

Before You Begin:

- 1) Please read all instructions and notes carefully. Check the Parts List or Bill of Materials for any missing parts and gather necessary tools. To prevent scratching of painted materials, place on a tarp, paper, or other protective material.
- 2) You may be required to obtain a building permit for this structure from your local building authority. Contact your local building department for details.
- 3) Note that this shade structure is not designed to carry additional loads such as hanging heavy plants, swings, people, or other objects.

Recommended Tools:

Safety Glasses, Tape Measure, Carpenters Level, Framing Square, Hex Head Nut Drivers, Chalk Line, Electric Drill w/ Bits, Pliers, Metal Hack Saw, Silicone Caulking, Regular and Phillips Screw Drivers

Note on Masonry Units:

If securing to stone, concrete, or other masonry unit, a masonry drill and bits may be required. You may also be required to purchase masonry anchor bolts, as the 1-1/2" lag screws provided will not be sufficient.

Note on Electric Drills:

We recommend lowering the speed of your drill during this installation. Installing Tek screws at a high rpm may cause the Tek screws to become damaged or break during installation.

Note on Cutting and Drilling:

Cutting and drilling will cause metal shavings. These shavings must be carefully removed by sweeping or brushing. If this is not done, the metal shavings will quickly rust and stain the surface finish.

If you have any questions during installation, please call us at 1-800-851-0865

Rev. - 5/04/10

SINGLE HEADER PERGOLA PARTS LIST

Contact us at:
1-800-851-0865 or
www.americana.com

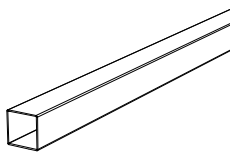

1. 3" x 3" Post

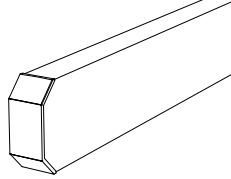

2. 3" x 8" Header

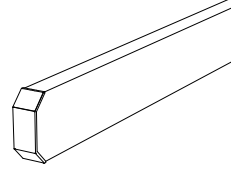

3. 2" x 6" Rafter

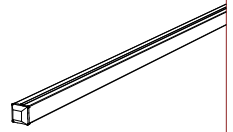

4. 1.5" x 1.5" Lattice



5. Post Mounting Bracket

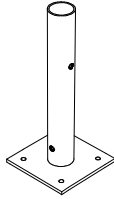

6. Heavy-Duty Post Mounting Bracket (Optional)

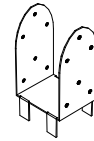

7. Post Top Bracket (Standard)



8. Post Top Bracket (Optional)



9. Rafter Hanging Bracket



10. Rafter Mounting Bracket

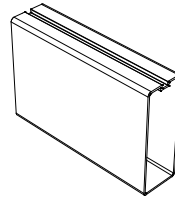

11. Header Splice (Optional)



12. Lattice Splice (Optional)

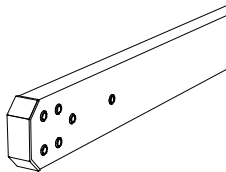

13. Post Side Plate (Foam Filled) (Optional)



14. 5/8" Hole Plug (Optional)

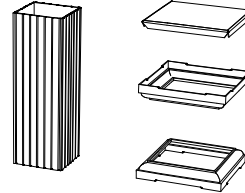

15. Column Wrap Kit (Square Shown) (Optional)

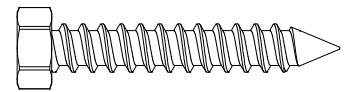

16. 1/4" x 1 1/2" Lag Screw

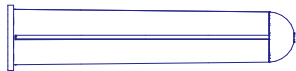

17. Lag Screw Insert

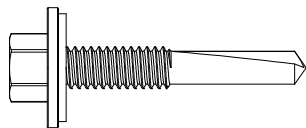

18. #12 x 1 1/4" HWH #5 Tek Screw

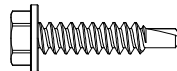

19. #8 x 3/4" HWH #2 Tek Screw

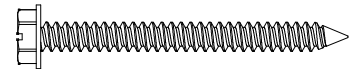

20. #10 x 2" Stainless Steel Sheet Metal Screw (SMS)

HEADER SPLICE (OPTIONAL)

- If the header is in two or more pieces, insert an equal amount of the provided header splice into each of the square ends of the headers and secure as shown using (12) #8 x 3/4" HWH #2 Tek Screws (see Fig. S-1).
- Be sure to place a post under the splice (see Fig. S-2).

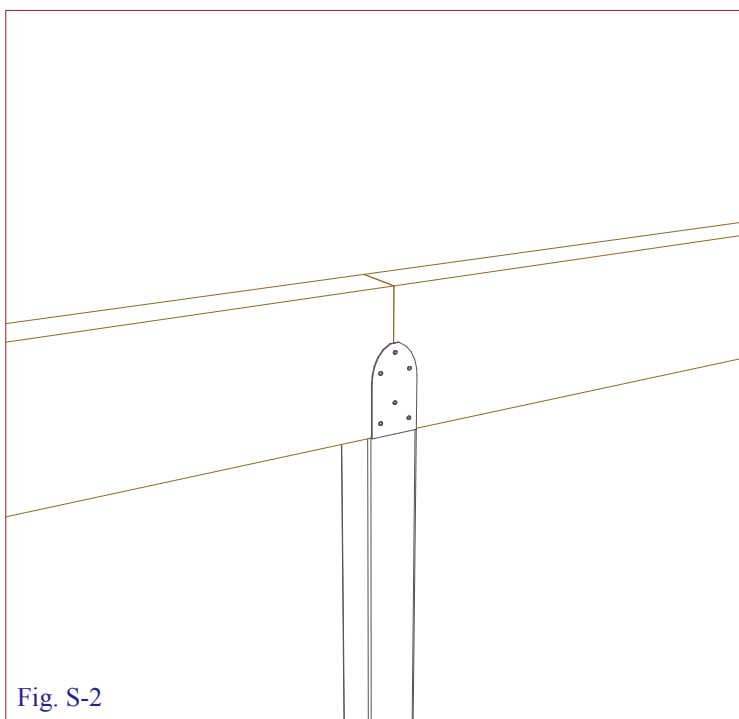
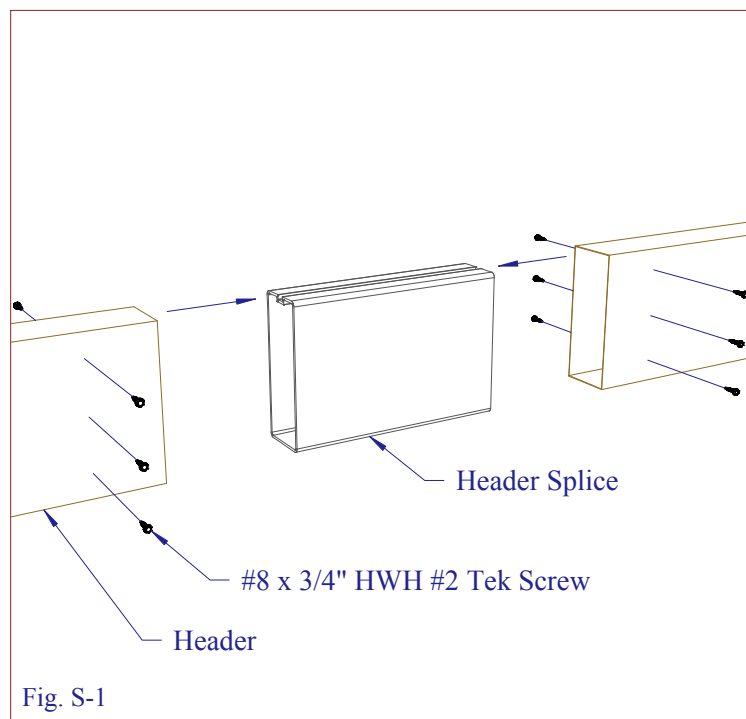

LATTICE SPLICE (OPTIONAL)

- If the lattice is in two or more pieces, insert a lattice splice into the ends of two tubes and secure with (2) #8 x 3/4" HWH #2 Tek screws (see Fig. S-3).

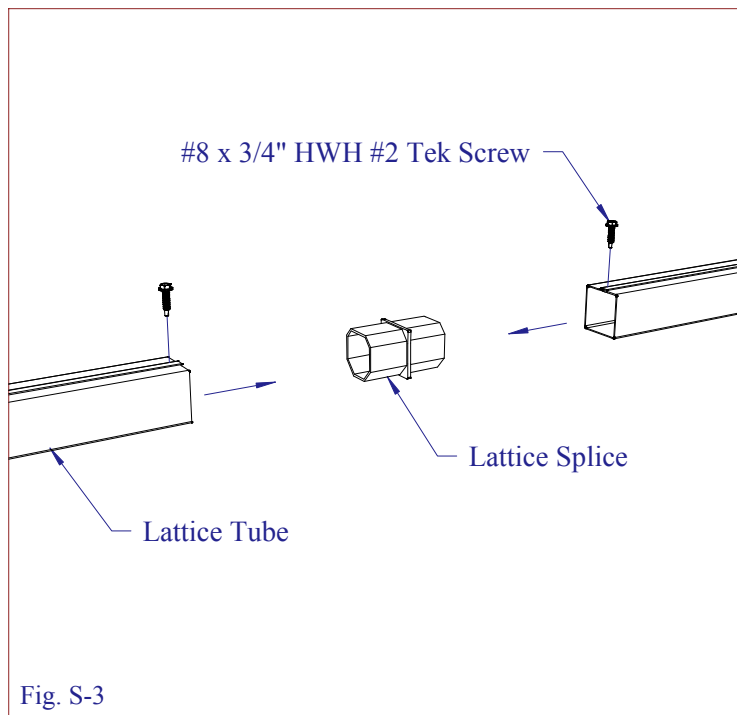

STEP 1

-Determine the location for your pergola and mark the outer edges by snapping a chalk line the length of the headers along the outer edge. Turn 90 degrees and snap a chalk line the length of your rafters beginning at the end of the previous chalk line. Repeat to close the square.

-Locate the center of the posts by subtracting the desired overhang from the overall dimensions and snap four chalk lines accordingly (see Fig. 1-1). NOTE: If drawings were received with your order, use those as the guide.

NOTE: If installing fiberglass columns, skip to Step 4 now and return to this step later.

-Depending on the available surface or local building codes, there are three post mounting options.

Option 1 - If your pergola has the standard post mounting brackets, anchor them at the intersection of two centerlines by drilling (4) 3/8" diameter holes and embedding (4) lag screw inserts. Then, attach the brackets to the surface using (4) 1/4" x 1 1/2" lag screws or appropriate anchors. Attach a post to each bracket using (4) #12 x 1 1/4" HWH #5 Tek screws (see Fig. 1-2).

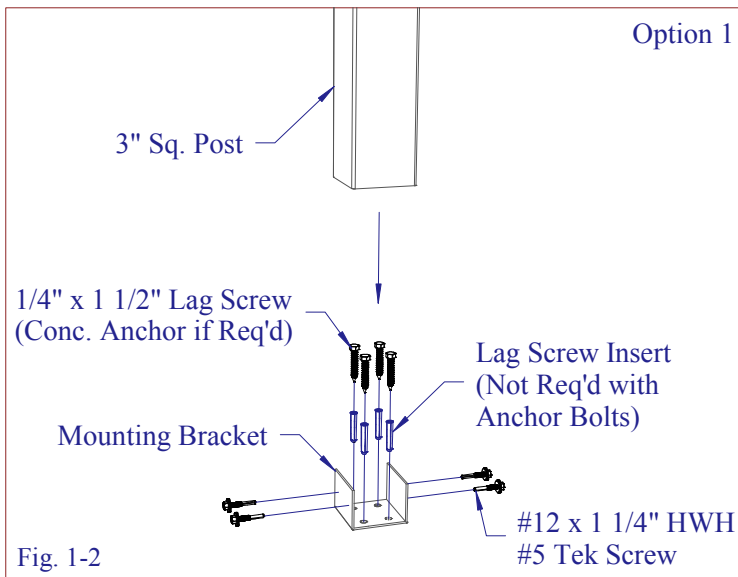
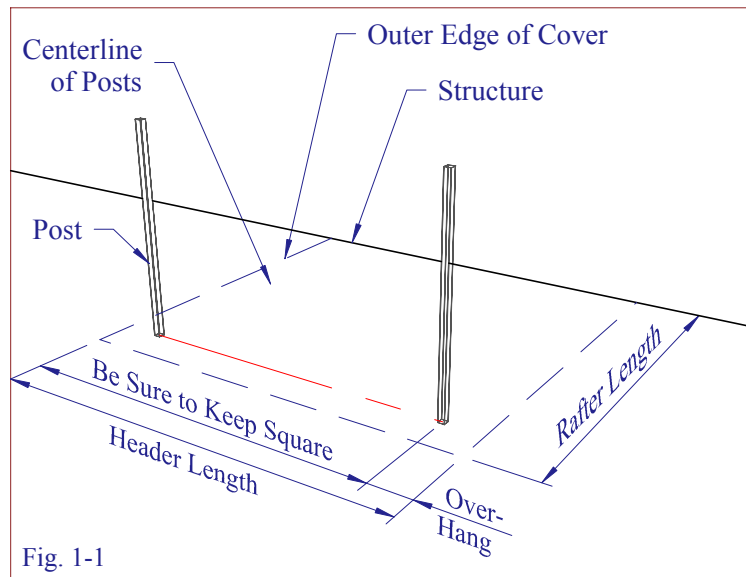

Option 2 - If your pergola has the heavy duty mounting brackets, anchor them at the intersection of two centerlines by drilling (4) holes for anchor bolts (not included, hole size will vary). Attach the bracket to the surface using (4) appropriate anchor bolts. Attach a post to each bracket using (2) 3/8" x 3 1/2" bolts (see Fig. 1-3). NOTE: If installing post side plates, only one bolt is required for the post to bracket connection. Run the bolt the same direction the header will run.

Option 3 - If you plan to bury the posts, start by digging a hole approximately 12" diameter and 30" deep. Place rock 6" deep in the bottom of the hole and drop the post in. Add or remove rocks as necessary to achieve the desired post height above ground. Fill the hole with a pre-mix of cement, aggregate, and water. Check the post on all sides with a carpenter's level to make sure it is plumb. (see Fig. 1-4). NOTE: Hole size and concrete mix must comply with local building codes.

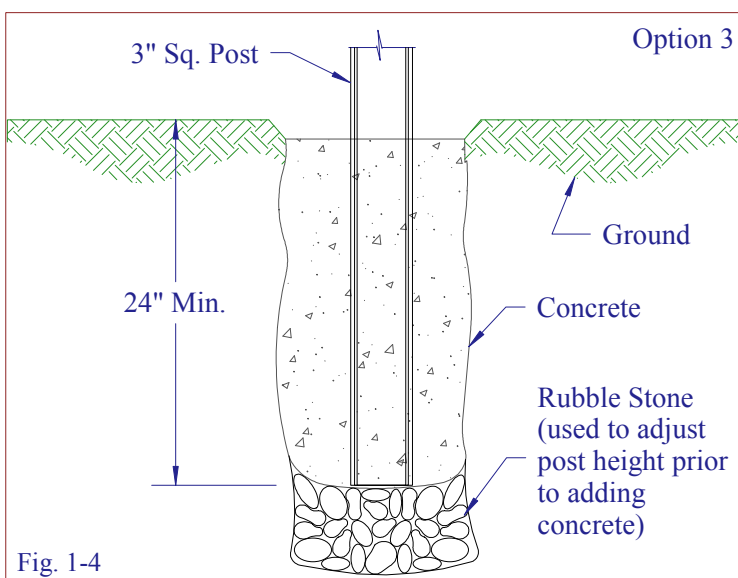
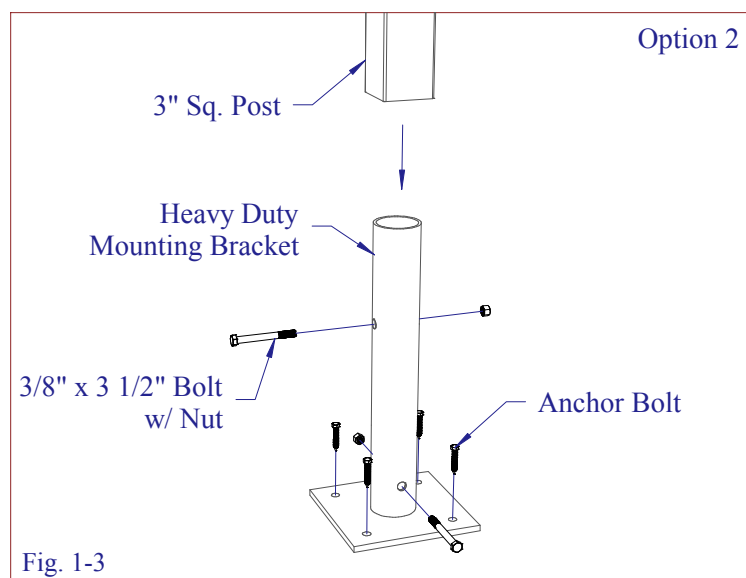

STEP 2

-Calculate Distance A using the formula shown in Fig. 2-1. Subtract one from the number of rafters and multiply that by the center to center spacing of the rafters. Subtract that from the length of the header and divide by two.

EXAMPLE: You received a 10'-0" long header and five rafters. The standard rafter spacing is 24" on center.

5 - 1 = 4; 4 x 24 = 96; 120 - 96 = 24; 24 / 2 = 12; Therefore, Distance A = 12".

-Once you know Distance A for your project, position a rafter mounting bracket with Distance A between the end of the header and the center of the bracket (see Fig. 2-1).

-Attach the bracket to the seam side of the header using (4) #8 x 3/4" HWH #2 Tek screws (see Fig. 2-2).

NOTE: If the header is reinforced with a beam inside, #12 x 1 1/4" HWH #5 Tek screws must be used instead.

-Position the next rafter mounting bracket with the rafter spacing between the centers of the two brackets and attach as shown.

-Repeat for all rafter mounting brackets.

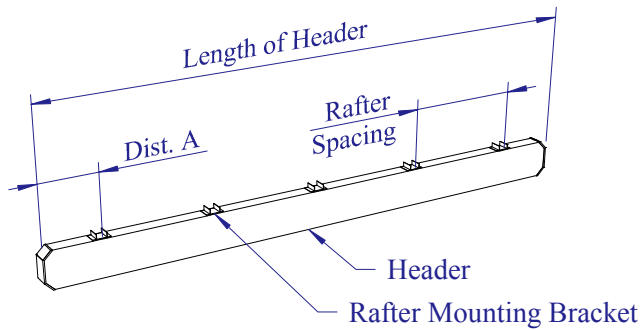

Dist. A =

$$\frac{\text{Length of Header} - [(\# \text{ of Rafters} - 1) \times \text{Rafter Spacing}]}{2}$$

Fig. 2-1

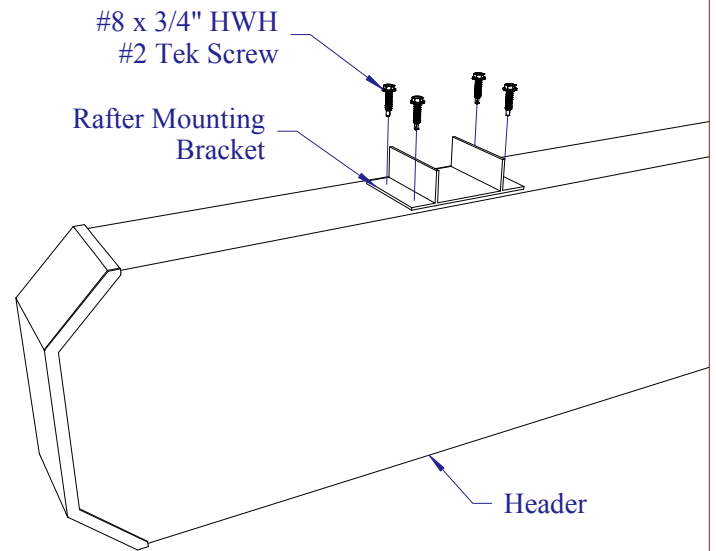

Fig. 2-2

-Mark the proper location for the post top brackets by calculating Distance B as shown in Fig. 2-3. Be sure that the spacing between the brackets attached to the header is equal to the spacing between the posts attached to the ground.

-If you received a column wrap kit with your pergola, attach the column plate to the header at the same location the post top bracket will be attached using (4) #8 x 3/4" HWH #2 Tek screws as shown (see Fig. 2-4).

-If you received the standard post top bracket, attach each to the header at the proper locations using (12) #8 x 3/4" HWH #2 Tek screws as shown (see Fig. 2-4a).

-If you received the optional post top bracket, attach each to the header at the proper locations using (4) #12 x 1 1/4" HWH #5 Tek screws as shown (see Fig. 2-4b).

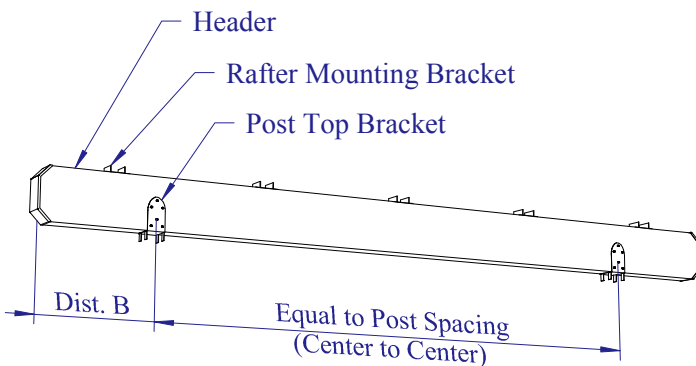

$$\text{Dist. B} = \frac{\text{Length of Header} - \text{Post Spacing}}{2}$$

Fig. 2-3

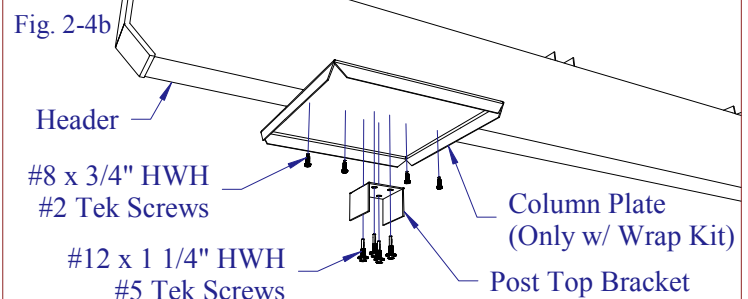
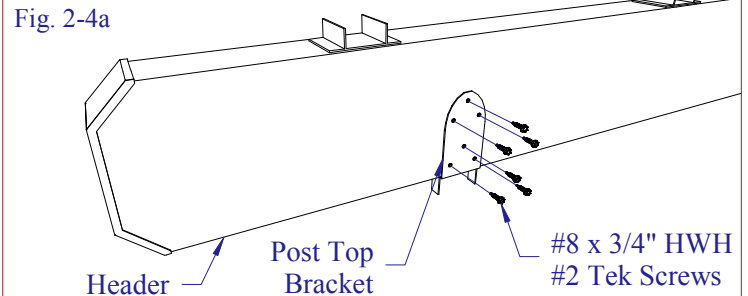

STEP 3

- Hoist the header assembly to the top of the posts and insert the post top brackets into the top of each post (see Fig. 3-1).
 - Secure the header assembly to each post using (4) #12 x 1 1/4" HWH #5 Tek screws per bracket (see Fig. 3-2).
- NOTE: This applies to both post top bracket types.

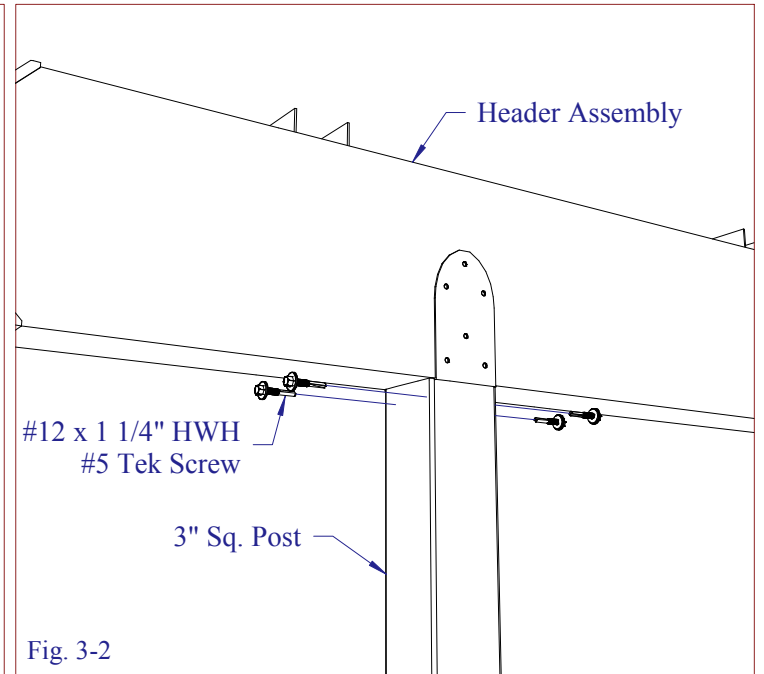
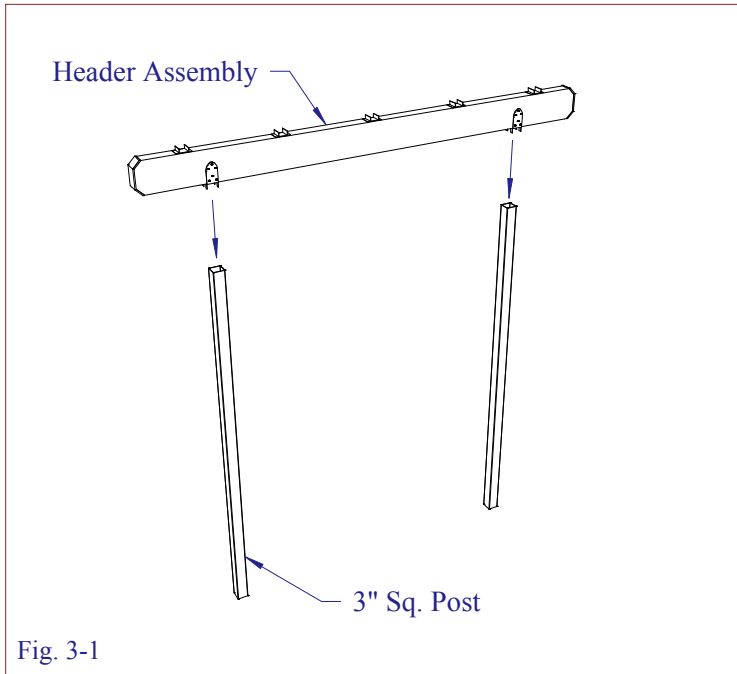

STEP 4 - OPTIONAL COLUMN KITS: SIDE PLATES

- If your pergola has side plates, center two per post in front of the post along the header (see Fig. 4-1).
- Attach the inside face of the side plate to the post using #12 x 1 1/4" HWH #5 Tek screws through the pre-drilled holes.
- Also attach the side plate to the header at the top using (4) #12 x 1 1/4" HWH #5 Tek screws (see Fig. 4-2).
- Insert a hole plug into all exposed holes.
- Repeat for each side plate.

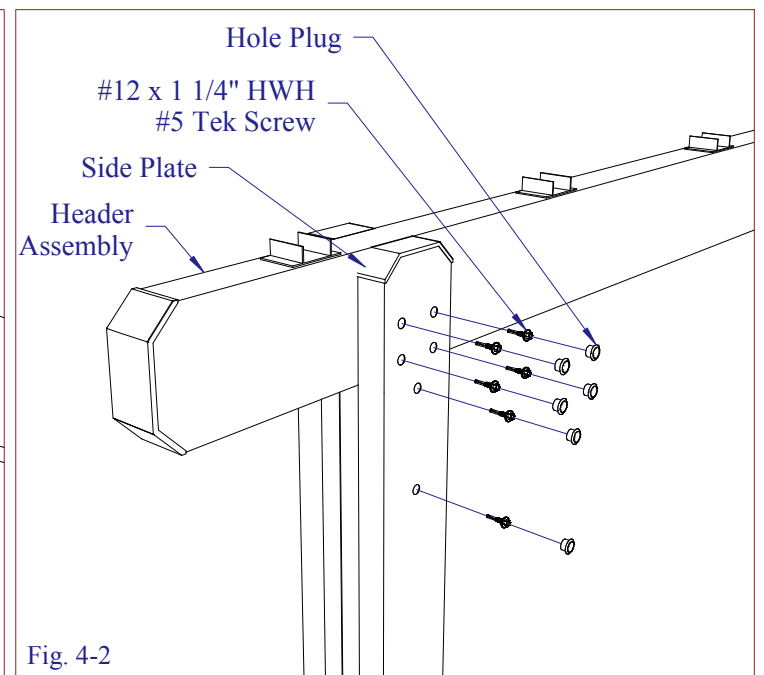
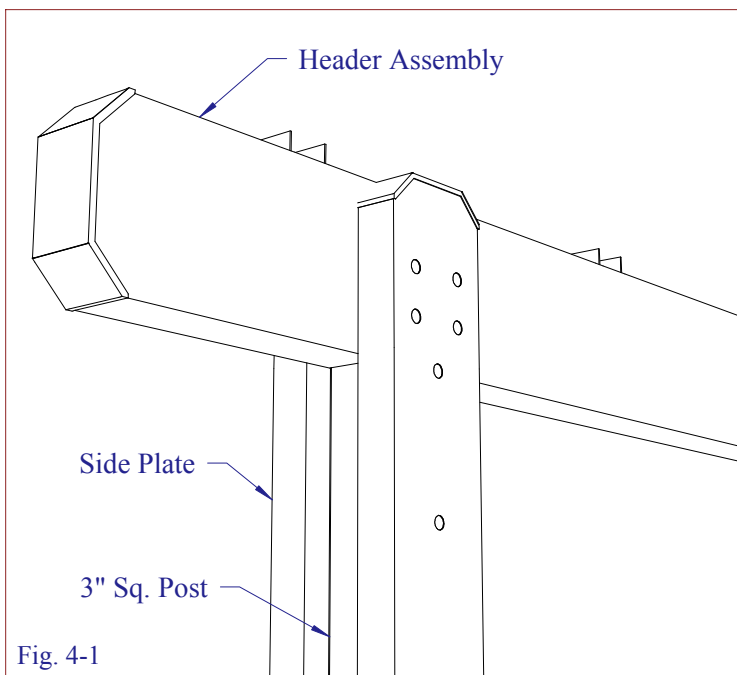

STEP 4 - OPTIONAL COLUMN KITS: SQUARE WRAP KIT

- Snap two column sections together by fitting the tongues into the grooves and lightly tapping with the heel of your hand.
- Once two sets of sections are locked together, stand them on end and snap the open ends together around a post (see Fig. 4-3).
- Anchor the bottom of the column with two lower column brackets, (6) lag screw inserts, (6) 1/4" x 1 1/2" lag screws into the surface, and (6) #8 x 3/4" HWH #2 Tek screws into the column (see Fig. 4-4).

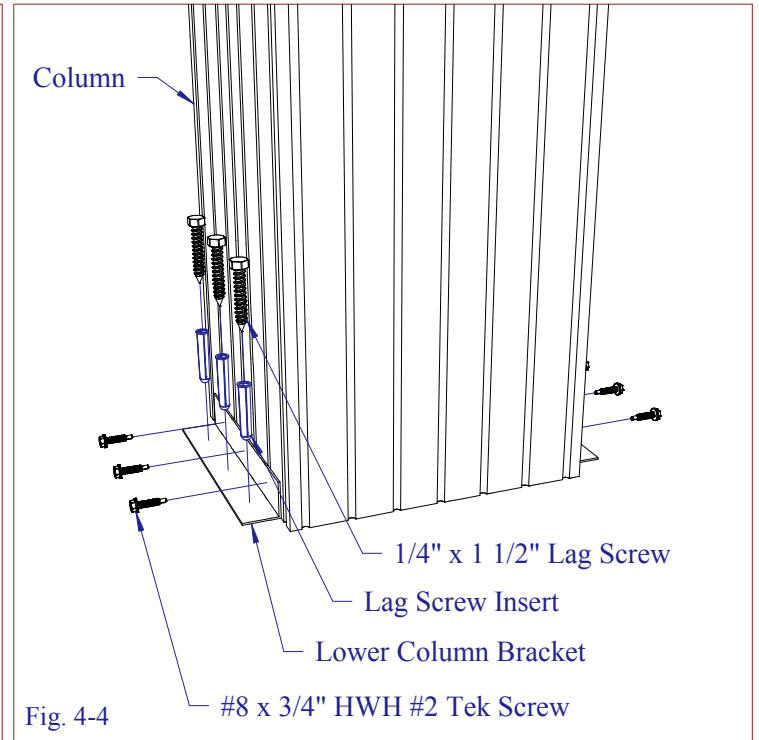
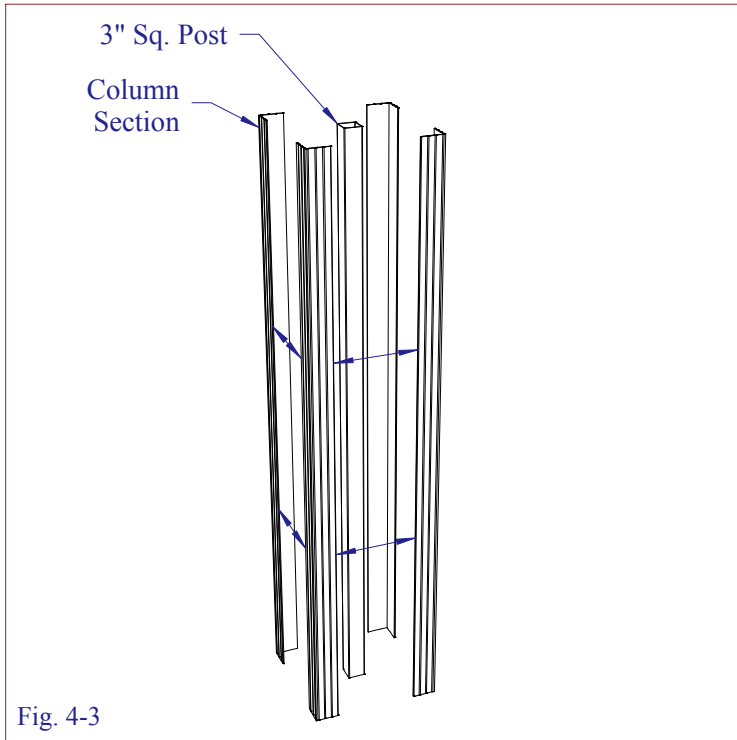

- Once the column sections are secure, assemble a column cap around the bottom of the column.
- Attach the column cap to the column using (6) #8 x 3/4" HWH #2 Tek screws as shown (see Fig. 4-5).
- Assemble another column cap around the top of the column.
- Push the column cap up until flush with the bottom of the header and attach to the column plate using (4) #8 x 3/4" HWH #2 Tek screws (see Fig. 4-6).
- Attach the column cap to the column using (6) #8 x 3/4" HWH #2 Tek screws as shown (see Fig. 4-6).

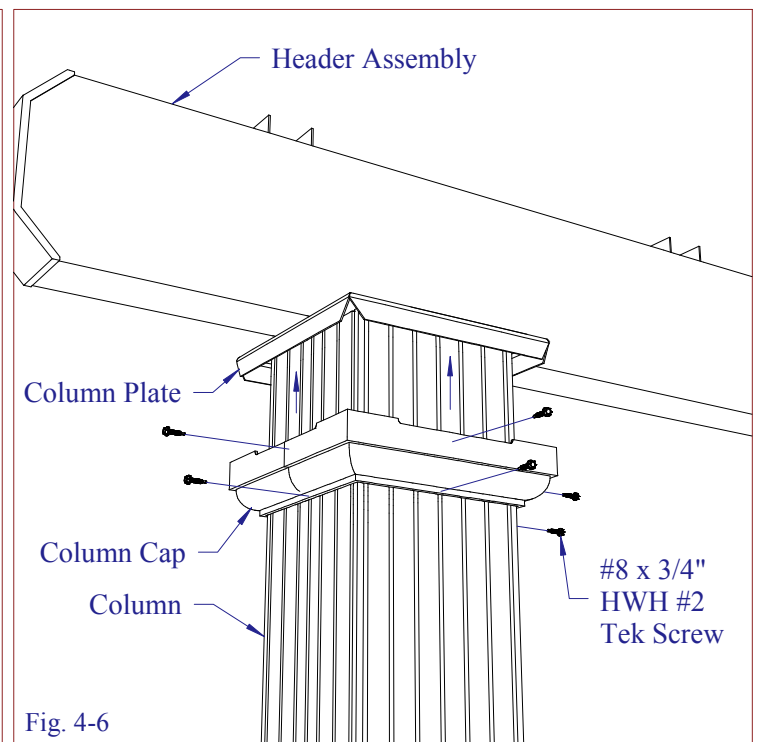
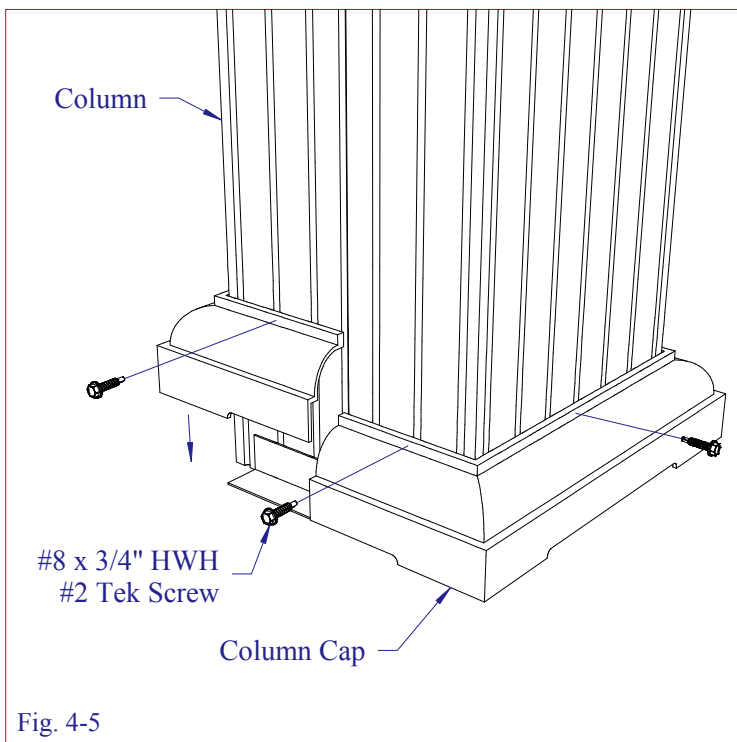

STEP 4 - OPTIONAL COLUMN KITS: ROUND WRAP KIT

- Snap two column sections together by fitting the tongues into the grooves and lightly tapping with the heel of your hand.
- Stand the sections on end and snap the open ends together around a post (see Fig. 4-7).
- Anchor the bottom of the column with three lower column brackets, (3) lag screw inserts, (3) 1/4" x 1 1/2" lag screws into the surface, and (3) #8 x 3/4" HWH #2 Tek screws into the column (see Fig. 4-8).

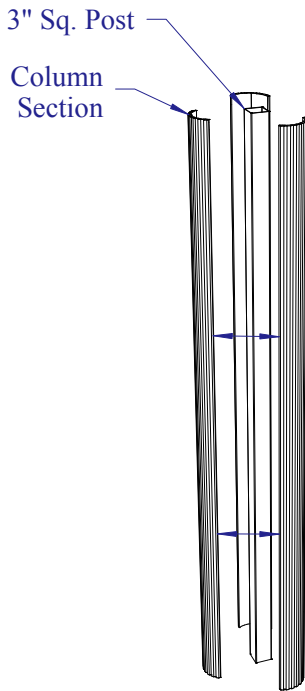

Fig. 4-7

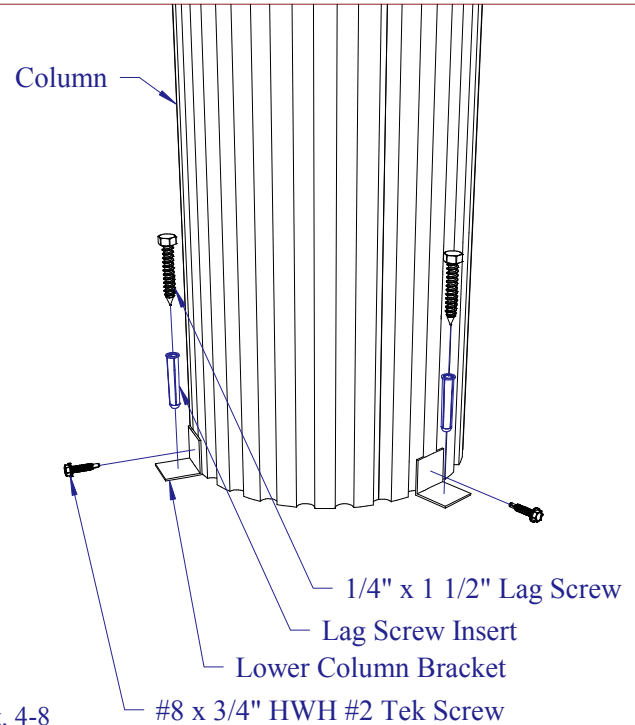

Fig. 4-8

- Once the column sections are secure, assemble a column cap around the bottom of the column.
- Attach the column cap to the column using (6) #8 x 3/4" HWH #2 Tek screws as shown (see Fig. 4-9).
- Assemble another column cap around the top of the column.
- Push the column cap up until flush with the bottom of the header and attach to the column plate using (4) #8 x 3/4" HWH #2 Tek screws (see Fig. 4-10).
- Attach the column cap to the column using (6) #8 x 3/4" HWH #2 Tek screws as shown (see Fig. 4-10).

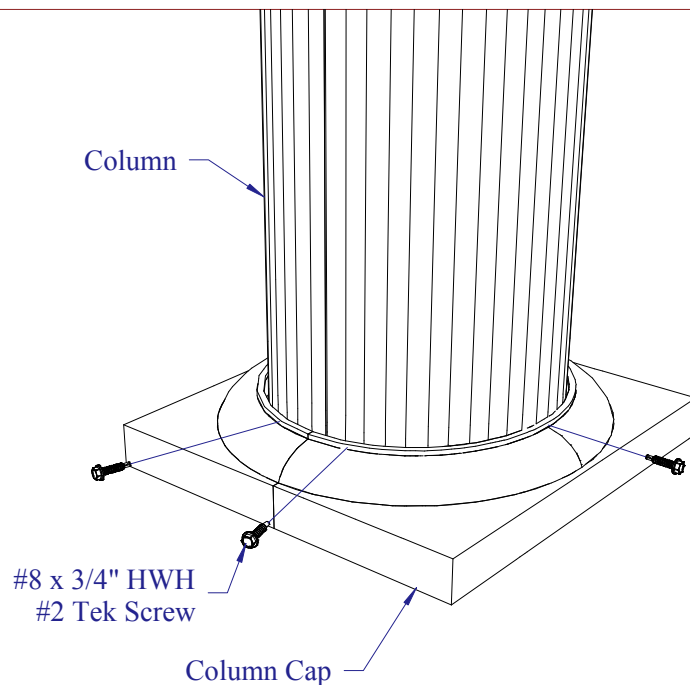

Fig. 4-9

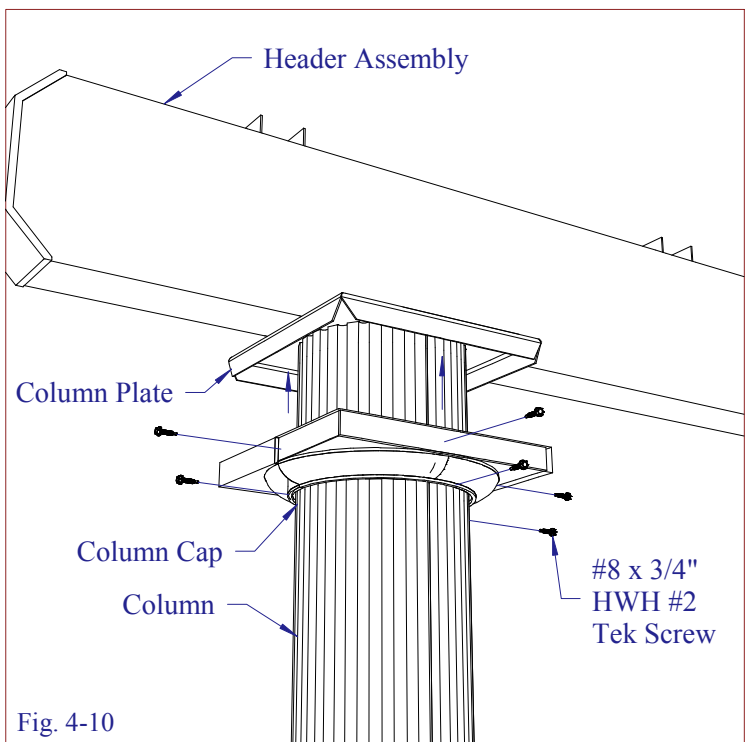

Fig. 4-10

STEP 4 - OPTIONAL COLUMN KITS: FIBERGLASS COLUMN

NOTE: Before installation, fiberglass columns must be painted. See below for color matching formulas.

TIP: Before painting, sand the column lightly with 120 grit or finer wet/dry sandpaper. Use mineral spirits to remove all dust/dirt.

- Start by measuring the required height of the column. If needed, trim off the bottom of the column.
- Cut a notch on opposite sides at the top of the column 3" wide and 2" deep (see Fig. 4-11). This is to allow room to attach the post to the post top bracket. The notches will be covered by the column cap.
- Slip the top and base column caps on the column. The top column cap may rest on the neck mold.
- Place the post inside the column and mark the exact mounting location. Apply construction adhesive on the ground in the area the bottom column cap will be. Continue with the proper option, depending of post mounting method.

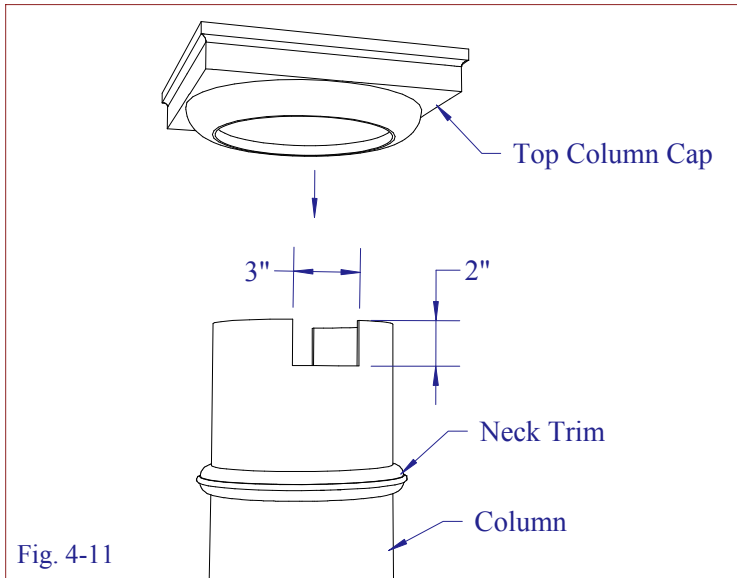

Fig. 4-11

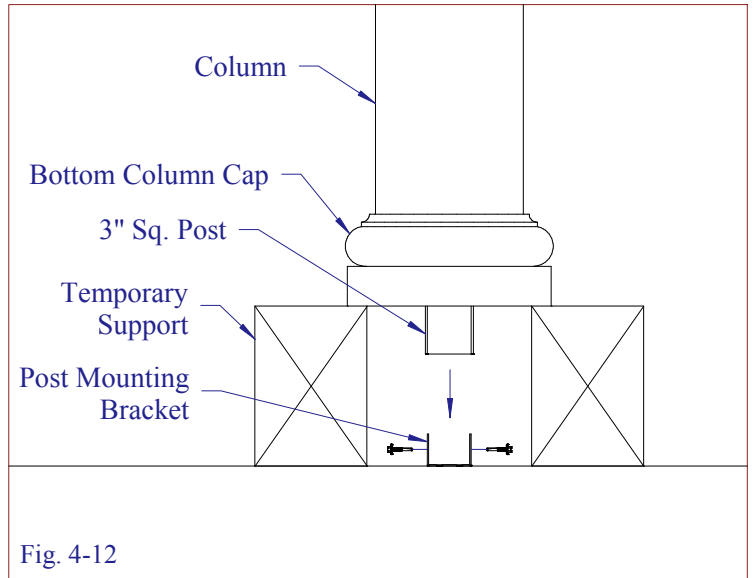

Fig. 4-12

Option 1 - If your pergola is surface mounted, anchor the post mounting brackets to the surface as shown in Fig. 1-2 or Fig. 1-3. Prop up the column using any type of support block as show in Fig 4-12. Let the post slide down and attach to the post mounting bracket as shown in Fig. 1-2 or Fig. 1-3. Remove the support blocks and anchor the bottom column cap.

Option 2 - If you plan to bury the posts, do so as instructed in Step 1 (see Fig. 1-4). Once posts are installed, hoist the column over the post and place around it. **WARNING:** Standard 8'-0" x 8" round fiberglass column weighs approximately 60 pounds; installation may require more than one person. Apply construction adhesive to the bottom surface of the column and anchor the bottom column cap.

-Once columns are installed, continue with installation from Step 2. After the header is attached (see Step 3), raise the top column cap and attach to the column plate using (4) #8 x 3/4" HWH #2 Tek screws (see Fig. 4-13).

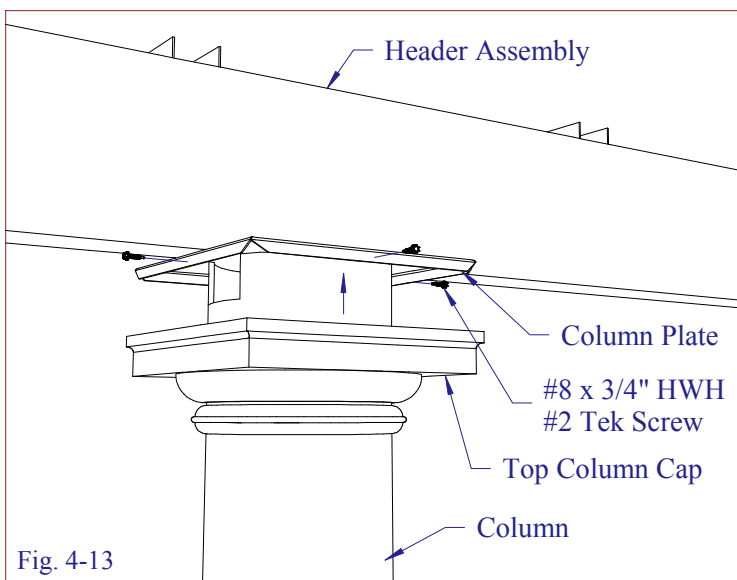

Fig. 4-13

Color Matching Formulas

Lowes - Valspar Paint 1 gallon
Exterior/Latex/Semi Gloss/Daylight

White
Base B1-20015
101 - 5 shot
103 - 1/2 shot
107 - 4 shot

Wicker
Base B1-20015
101 - 18 shot
107 - 25 1/2 shot
109 - 3 1/2 shot

Adobe (Clay)
Base B1-20036
101 (1y oz) - 45 1/2 shot
104 (1y oz) - 12 1/2 shot
111 (1y oz) - 32 shot

Latte
Base B1-20015
101 - 37 1/2 shot
107 (2y oz) - 19 1/2 shot
109 - 17 1/2 shot

STEP 5

- Begin rafter hanging bracket installation by snapping a level chalk line along the wall to locate the bottom of the rafters.
- To determine the height of the line, simply add the height of the posts and the height of the header.
- Locate and mark a centerline on the wall for each rafter hanging bracket adjacent to the rafter mounting brackets on the header.
- Pre-drill (2) 5/16" holes in the wall, being sure to hit a solid anchor point. Attach a rafter hanging bracket to the wall using (2) 1/4" x 1 1/2" lag screws and lag screw inserts.
- NOTE: If a solid anchor such as a wall stud can not be located, a ledger board may be required (not supplied by manufacturer).
- Attach a rafter seam side up to the bracket using (4) #8 x 3/4" HWH #2 Tek screws (see Fig. 5-1).
- Attach the rafters to the rafter mounting brackets using (4) #8 x 3/4" HWH #2 Tek screws per bracket (see Fig. 5-2).

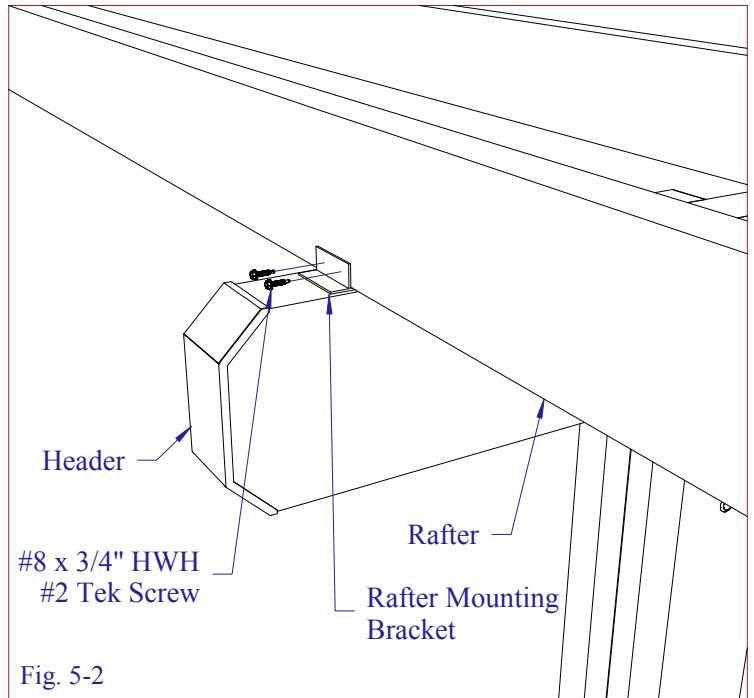
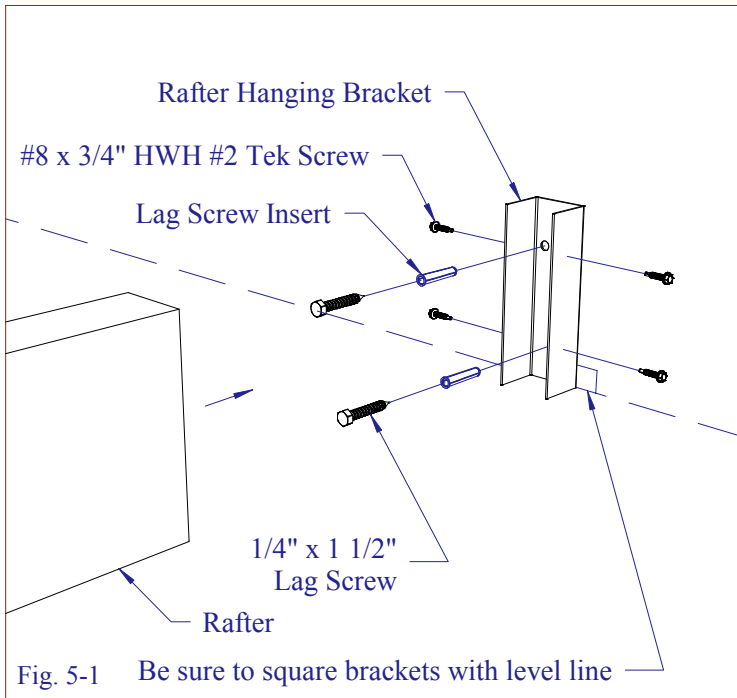

- After all rafters are installed, layout the lattice tubes on the rafters with the seam side facing up. See Fig. 5-3 for lattice spacing details. Similar to how you determined Distance A in Step 2, subtract one from the number of lattice tubes and multiply that by the center to center spacing of the lattice. Subtract that from the length of the rafter and divide by two.
- The standard lattice spacing is 4 1/2" on center. If this is the case for your project, you might have received a short piece of 3" square tube. Simply placing this between two lattice tubes will give you the correct lattice spacing.
- Once a lattice tube is in the correct position, attach it to each rafter using #10 x 2" sheet metal screws (see Fig. 5-4).

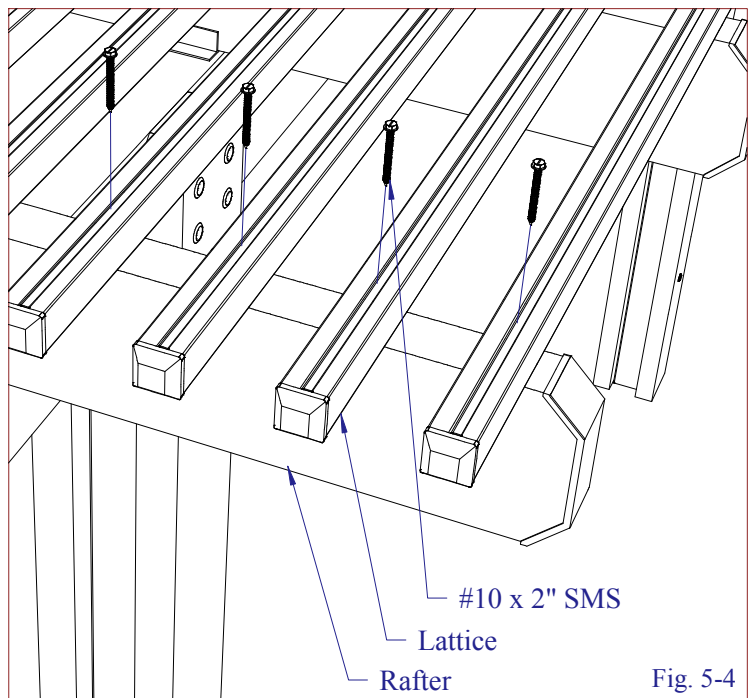
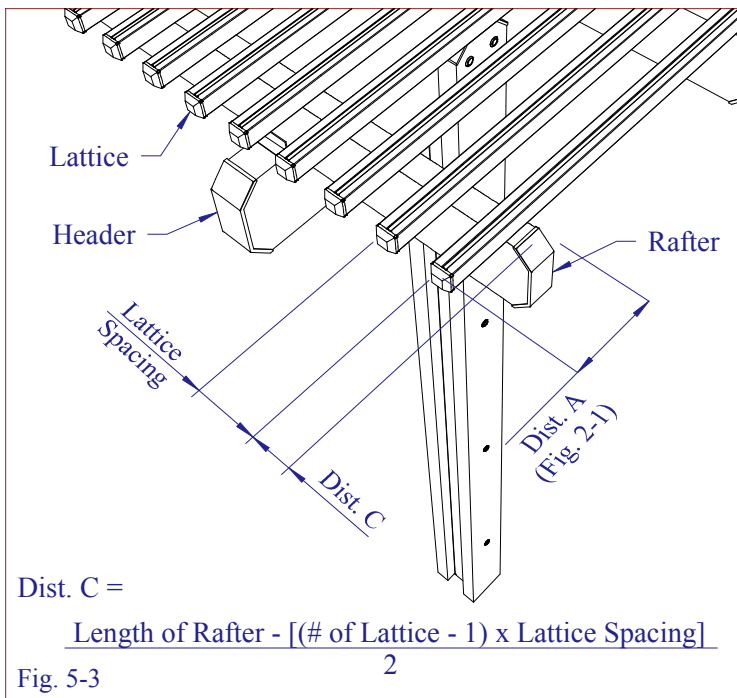

ASSEMBLY COMPLETED

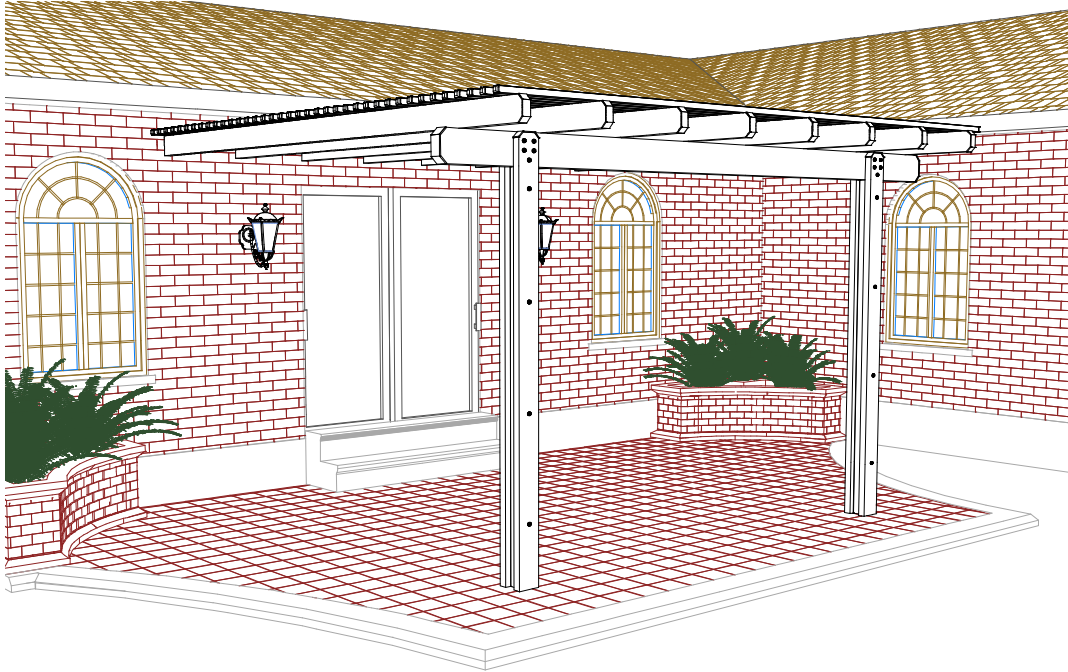

Other Products Available from AMERICANA BUILDING PRODUCTS:

Fabric Window Awnings, Aluminum Patio Covers and Window Awnings, Glass Enclosures, Screen Enclosures, Park Shelters, Aluminum Railings and Columns, Retractable Fabric Awnings, and More

NOTES