



**Model #VWD2265W**

## **High Efficiency Water Dispenser**

---

### **Use & Care Guide**



**Questions, problems, missing parts?  
Before returning to the store, please call  
GHP Group Customer Service  
Toll Free at 1-877-447-4768 between  
8 a.m. - 4:30 p.m., CST, Monday - Friday**

PLEASE READ THIS MANUAL  
THOROUGHLY BEFORE USING THE  
APPLIANCE AND KEEP THIS MANUAL  
FOR FUTURE REFERENCE

---

### ***THANK YOU***

**We appreciate the trust and confidence you have placed in Greenway Home Products through the purchase of this water dispenser. We strive to continually create quality products designed to enhance your home. Visit us online to see our full line of products available at [www.greenwayhp.com](http://www.greenwayhp.com). Thank you for choosing Vitapur!**

# Safety Information



**Warning:** Never put anything flammable close to the dispenser



**Warning:** This water dispenser is designed for INDOOR applications only.



**Warning:** Do not damage the refrigeration cooling system.



**Warning:** This Product can expose you to chemicals including Diisononyl phthalate (DINP) which is known to the State of California to cause cancer and Di-isodecyl phthalates (DIDP) which is known to the State of California to cause birth defects or other reproductive harm.

**For more information go to [www.p65Warnings.ca.gov](http://www.p65Warnings.ca.gov)**



**Important:** Refrigerants must be handled and disposed of by qualified service personnel only. Before discarding this water dispenser to landfill, contact local authorities for advice on proper disposal methods for refrigerants.

1. Never turn the dispenser upside down or tilt more than 45 degrees. If the unit has been resting on its' side for a long period of time, place the water dispenser in the upright position for approximately 12 hours before turning it on.
2. For use with 3, 4 or 5 gallon (12, 15 or 19 liter) water bottles.
3. Never use this dispenser with water that is unsafe to drink or is from an unknown source.
4. Never use any other liquid in the dispenser other than known and microbiologically safe bottled water.
5. This water dispenser is equipped with a grounded power cord plug for your safety.
6. Keep your water dispenser in a dry place away from direct sunlight.
7. Leave a minimum of 2" (5 cm) around the back and sides of the dispenser for proper ventilation.
8. Always install your water dispenser on a level floor. Wait 3 minutes before restarting machine after shutting it down.
9. Always unplug the water dispenser before servicing.
10. Regular cleaning of your water dispenser is required for your warranty. Please follow the cleaning instructions outlined in this manual and clean the dispenser every 4 months.

# Pre-Operation

## GROUNDING PRECAUTIONS

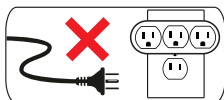
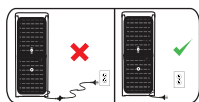
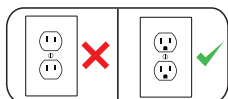

## WARNING

### ELECTRICAL REQUIREMENTS:

A 115 Volt, 60 Hz., AC only 15 amperes fused, grounded electrical supply is required. It is recommended that a separate circuit serving only your Water Dispenser be provided. Use an outlet that cannot be turned off by a switch.



## WARNING

**FAILURE TO FOLLOW THESE INSTRUCTIONS CAN RESULT IN DEATH, FIRE, OR ELECTRICAL SHOCK**

### GROUNDING INSTRUCTIONS:

- **Warning:** This appliance must be grounded. In the event of an electrical short circuit, grounding reduces the risk of electric shock by providing an escape wire for electric current.
- **Warning:** Improper use of the grounding plug can result in a risk of property damage, electric shock causing serious injury, even death.
- **Warning:** This appliance is equipped with a power cord having a grounding wire with a grounding plug and must be connected into a properly grounded polarized outlet. Consult a qualified electrician if the grounding instructions are not completely understood, or if doubt exists as to whether the wall outlet is properly grounded.
- **Warning:** If the wall outlet is a standard 2 prong outlet, it is your personal responsibility and obligation to have it replaced with a properly grounded 3-prong wall outlet.
- **Warning:** Do not under any circumstances cut or remove the third (ground) pin from the power cord plug.
- **Warning:** Do not use adapter plugs or extension cords with this appliance.
- **Warning:** If the power cord is too short, have a qualified electrician install an electrical outlet near the appliance.
- **Warning:** Do NOT use the appliance if the power cord becomes frayed or otherwise damaged.

## SPECIFICATIONS

Model No.	VWD2265W
Dimensions W x D x H	11.4 in. x 11.8 in. x 33.9 in. • 29cm x 30cm x 86cm
Net Weight / Gross Weight	23.1 lbs / 27.5 lbs • 10.5 kg / 12.5 kg
Cooling Temp (approx.).	39 °F / 3.8 °C
	<b>COLD</b>
Power Consumption	80W

# Warranty

Do not return this product to the store: Please contact Customer Service at 1-877-447-4768.

The supplier warrants your water dispenser to be free from manufacturing defects in workmanship or material under normal operating conditions for one (1) year from the original date of purchase. This warranty applies only in the country in which it is sold and is available to the original purchaser only. This warranty is non-transferable.

This warranty and the CSA International listing for this water dispenser are void if the water dispenser is altered, modified, or combined with any other machine or device. Alteration of this water dispenser may cause serious flooding and/or hazardous electrical shock or fire.

The provisions of this warranty shall not apply to:

- Water bottles
- Service trips to your home to teach you how to use the product
- Improper installation, delivery, or maintenance (Failure to maintain the product according to the instructions outlined in the product manual will automatically void the warranty.)
- Failure of the product due to abuse, misuse, alteration, commercial use, or any use for which the product was not intended
- Products that are used outside a residential or office environment
- Replacement of house fuses or resetting of circuit breakers
- Use of this product where water is microbiologically unsafe or of unknown quality
- Damage to the product if used to dispense anything other than water
- Damage to the product caused by accident, fire, floods, or acts of God
- Any service to the product by unauthorized personnel
- Incidental or consequential damage caused by possible defects with this appliance, its installation or repair

This warranty shall be fulfilled at an authorized repair facility. All warranty repairs must be pre-authorized by the supplier. The supplier will, at its option, repair or replace free of charge any defective part, where the purchaser has notified their retailer within the warranty period. The obligation of the supplier under this warranty is expressly limited to such repairs or replacement. This warranty does not cover the freight costs to and from the authorized repair facility.

Except as set forth herein or required by law, the manufacturer makes no other warranty, guarantee, or agreement, express, implied, or statutory, including any implied warranty of merchantability or fitness for a particular purpose.

# Warranty

The manufacturer does not assume or authorize any person to assume any obligations of liability in connection with this water dispenser. In no event will the manufacturer be liable for indirect, special, or consequential damages (including, without limitation, economic loss) or for any delay in the performance of this agreement due to causes beyond its control.

Some states or provinces do not allow limitations on how long an implied warranty lasts, so the above limitation may not apply to you. Some states or provinces do not allow the exclusion or limitation of incidental or consequential damages, so the above limitation or exclusion may not apply to you. This warranty gives you specific legal rights, and you may also have other rights which vary from state to state or from province to province.

If you require service, please first see the “Troubleshooting” section of this manual. Additional assistance can be found by calling our customer service line at 1-877-447-4768.

***Keep this manual and your sales slip together for future reference. You must provide proof of purchase for in-warranty service.***

Write down the complete model number and serial number of your water dispenser to better help you obtain assistance or service if you ever need it. You can find this information on the back of the water dispenser

# Pre-Operation (continued)

## PACKAGE CONTENTS

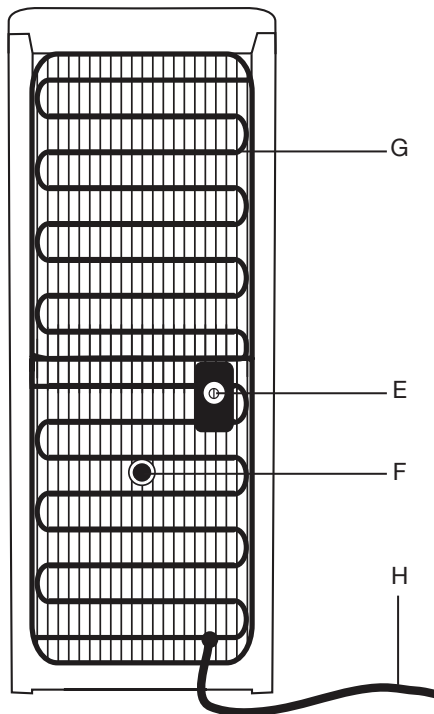
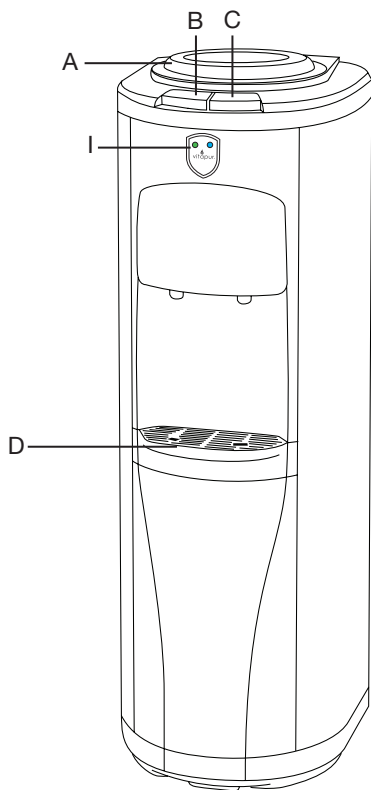

Part	Description	QTY
A	Bottle support collar	1
B	Room temperature water dispensing button	1
C	Cold water dispensing button	1
D	Removable drip tray	1

Part	Description	QTY
E	Adjustable cold water thermostat	1
F	Drain valve	1
G	Condenser Coils	1
H	Power cord	1
I	Ready-to Dispense Indicator Lights (Green = Power On) (Blue = Cold Water Ready)	2

# Pre-Operation (continued)

## INITIAL PRODUCT CLEANING PROCEDURE

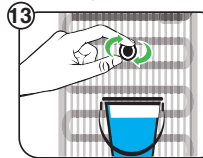
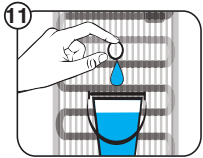
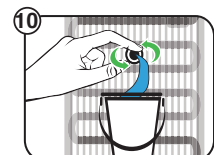
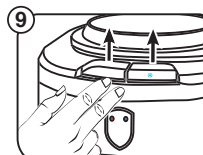
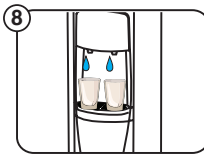
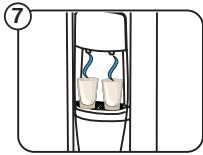
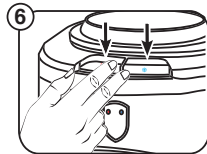
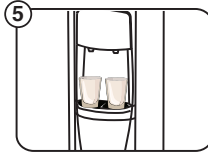
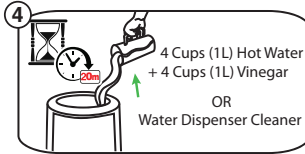
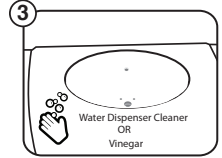
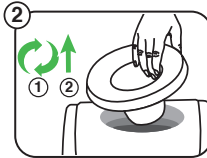
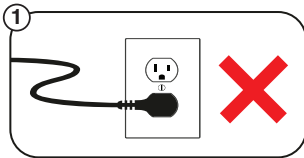

## INSTALLING THE WATER BOTTLE

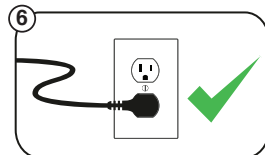
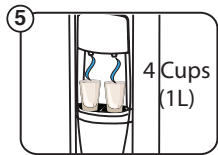
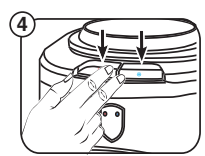
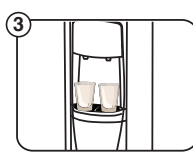
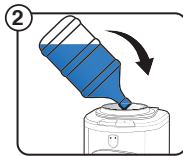
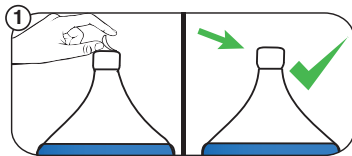
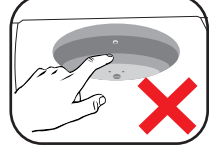
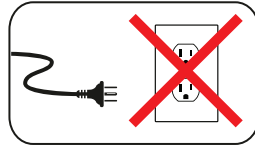
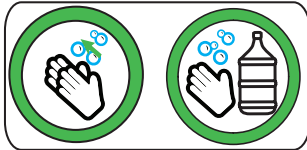

# Operation

## 1. DISPENSING COLD WATER



## 2. DISPENSING ROOM TEMPERATURE WATER

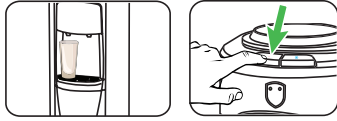

## 3. ADJUSTING THE COLD WATER TEMPERATURE

◇ By turning the thermostat (G) at the back of the unit, the temperature can be adjusted. Turn the dial clock wise between the Min. (cool) and Max. (colder) levels until the desired temperature is reached.

**Note:** If the water dispenser is not dispensing water, there could be a possible ice build up due to the thermostat being set too cold. If this happens, unplug the dispenser overnight and then reset. Set thermostat to Min, slowly increasing based on your use and need for cold water.

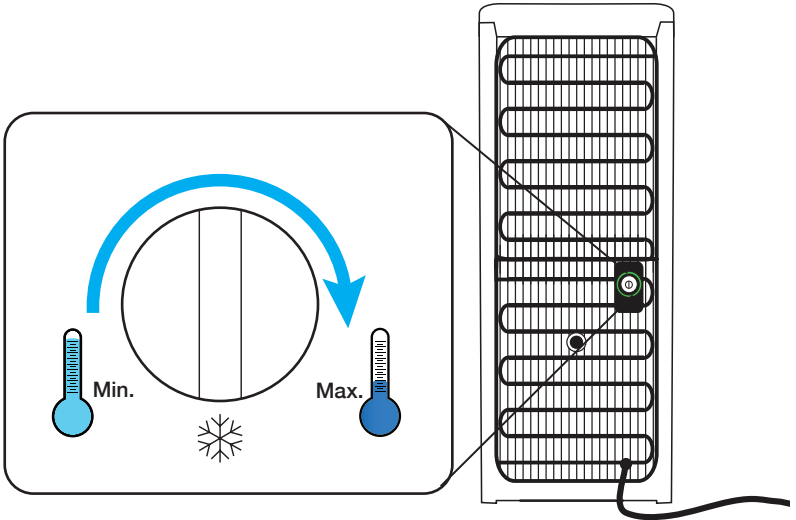



# Care and Cleaning

## CLEANING THE OUTSIDE OF THE WATER DISPENSER

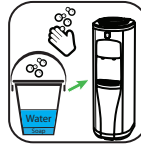
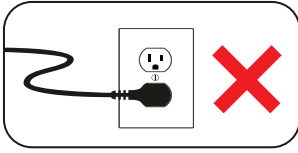

## CLEANING THE DRIP TRAY

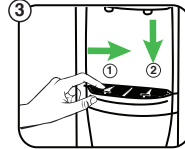
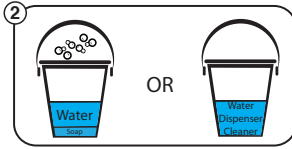

## CLEANING THE CONDENSER

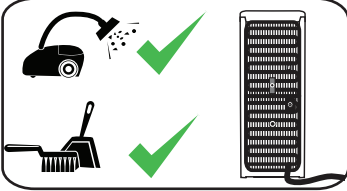

## DRAINING THE RESERVOIRS

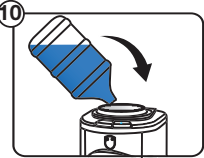
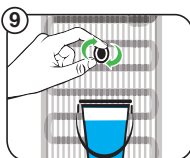
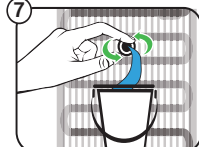
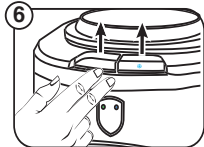
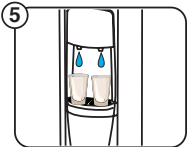
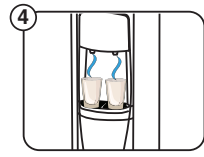
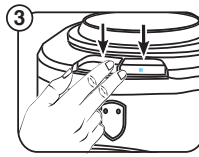
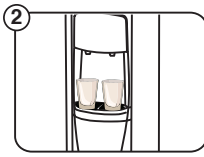
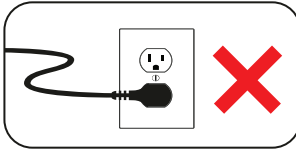

## CLEANING THE INSIDE OF THE DISPENSER

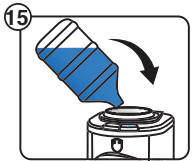
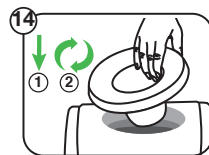
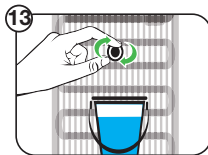
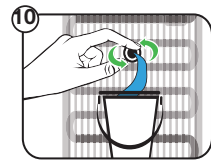
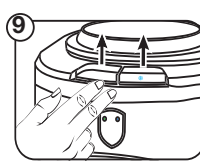
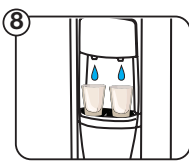
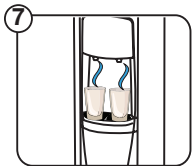
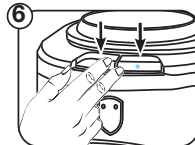
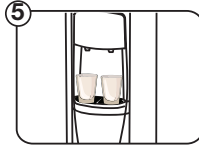
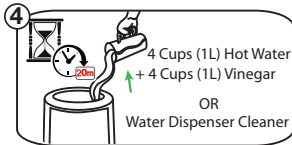
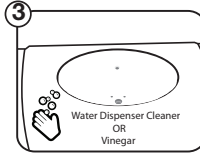
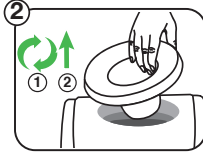
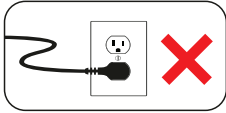

## GOING AWAY ON VACATION

When not using the dispenser for long periods of time or when going on vacation, unplug the dispenser and drain the reservoirs (see Draining the Reservoirs). Follow Initial Product Cleaning Procedures upon return and startup of the dispenser.

## FREQUENTLY ASKED QUESTIONS

**Q: Why do I get a plastic taste from my dispenser?**

**A:** As with most new appliances such as coffee makers and kettles, there is often a plastic taste upon initial start-up of the unit. To remove this taste, simply follow the cleaning instructions outlined in Cleaning the Inside of the Dispenser.

**Q: What is the spike that goes into the bottle?**

**A:** Vitapur® water dispensers feature a “piercing valve” as part of the bottle support collar, providing added convenience for water bottle installation. Depending on the water bottle supplier, some water bottles incorporate a self-piercing membrane in the bottle cap for this specific purpose (ask your water bottle supplier if your water bottle incorporates this feature). If your water bottle does not incorporate this feature, the entire bottle cap must then be removed to eliminate possible damage to the piercing valve.

# Troubleshooting

Problem	Possible Cause	Suggested Solution
Water dispenser is leaking	Drain cap and silicone seal are not secure.	Ensure seal is secure in drain plug and tighten drain cap.
	Water was poured directly into bottle support collar and overflowed.	Drain by pressing dispenser taps.
Water is not cold enough	All the water in the tank has been used.	Replace with full bottle and wait; 30 minutes for water to cool.
	The unit is unplugged.	Plug it into the outlet.
	The circuit breaker in your home is tripped or the fuse has blown.	Reset the breaker or replace the fuse.
	Thermostat needs to be adjusted colder.	Adjust thermostat between "MIN" (cool) and "MAX" (colder) levels to achieve desired temperature.
Water dispenser is not dispensing water	Empty water bottle.	Replace with full bottle.
	Mineral deposits clogging tanks.	See Cleaning the Reservoirs.
	Possible air pocket.	Push down on the dispenser buttons to prime the unit.
	Possible ice build up due to thermostat set too cold.	Unplug overnight, then reset. Set thermostat to high, slowly increasing based on your use and need for cold water.
Water dispenser is noisy	Bottle making a gurgling noise as it fills the tank.	This is normal.
	Water dispenser is uneven.	Make sure the dispenser is on an even surface that can support its full weight.

**Note:** Do not return this product to the store. For questions on operation, assembly or parts, please contact us at 1-877-447-4768 for further assistance.

# ANTI-LEAK BOTTLE SUPPORT COLLAR

The bottle support collar on your water dispenser is engineered with a special anti-leak-proof system to prevent accidental loss of water, (flooding) as a result of inadvertently installing a defective water bottle. Unfortunately, not all water bottles are created equal. Almost all 3, 4 and 5 gallon (12, 15 and 19 liter) water bottles are recycled and handled extensively during cleaning, filling, and shipping. As a result, they are very prone to developing hairline fractures and pinhole leaks that are not always obvious to the end user until the time of installation.



**Important:** Never knowingly install a defective water bottle on a water dispenser. Return immediately for replacement. If you are experiencing a leak, this simple test will allow you to determine whether your water bottle or dispenser is the source of the problem.

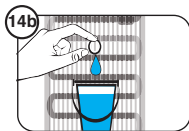
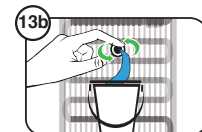
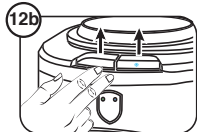
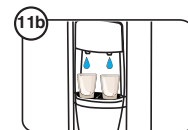
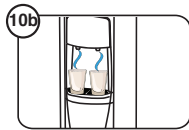
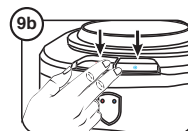
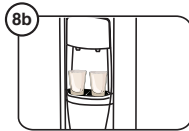
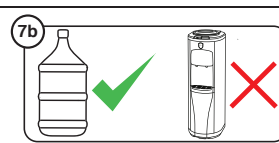
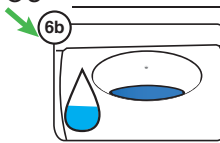
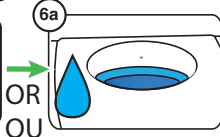
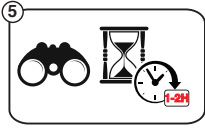
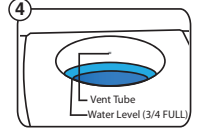
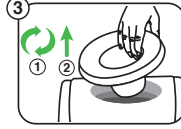
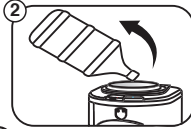
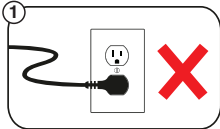

16b



1-877-447-4768  
CUSTOMER SERVICE



Modèle #VWD2265W

## Distributeur d'eau à rendement élevé

### Guide d'utilisation et d'entretien

Questions, problèmes, pièces manquantes? Avant de retourner au magasin, veuillez contacter le service à la clientèle de GHP Group au numéro sans frais 1-877-447-4768 entre 8 h et 16 h 30, HNC, du lundi au vendredi

VEUILLEZ LIRE CE MANUEL  
ATTENTIVEMENT AVANT D'UTILISER  
L'APPAREIL ET CONSERVER CE  
MANUEL POUR CONSULTATION  
ULTÉRIEURE





### **MERCI**

Nous apprécions la confiance que vous avez placée dans GHP Group par l'achat de ce distributeur d'eau. Nous nous efforçons de créer continuellement des produits de qualité conçus pour améliorer votre maison. Visitez-nous en ligne pour voir notre gamme complète de produits disponibles pour votre amélioration de la maison à besoin. Allez sur notre site pour voir notre gamme complète de produits pour votre maison à [www.ghpgroupinc.com](http://www.ghpgroupinc.com). Merci d'avoir choisi de Vitapur!

## Renseignements de sécurité

 **Avertissement:** Ne placez jamais de matière inflammable à proximité du distributeur.

 **Avertissement:** Ce distributeur d'eau est conçu pour des applications d'intérieur seulement.

 **Avertissement:** Ne pas endommager le système de réfrigération et de climatisation.

 **Avertissement:** Ce produit peut vous exposer à des agents chimiques, dont le phtalate de diisononyl (DINP), reconnu par l'État de Californie comme pouvant causer le cancer, ainsi que les phtalates diisodécyle (DIDP) reconnus par l'État de Californie comme pouvant causer des anomalies congénitales et autres dommages au système reproducteur.

**Pour plus de renseignements, visitez le [www.p65Warnings.ca.gov](http://www.p65Warnings.ca.gov)**

 **Important:** Les fluides frigorigènes doivent être manipulés et jetés uniquement par du personnel de service qualifié. Avant de jeter ce distributeur d'eau au site d'enfouissement, contactez les autorités locales pour obtenir des conseils sur les méthodes d'élimination appropriées concernant les fluides frigorigènes.

1. Ne retournez jamais le distributeur d'eau et ne l'inclinez pas à plus de 45 degrés. Si l'appareil est resté sur le côté pendant un long moment, placez le distributeur d'eau à la verticale pendant 12 heures environ avant de le brancher.
2. Doit être utilisé avec des bouteilles d'eau de 3, 4 ou de 5 gallons (12, 15 ou 19 litres).
3. N'employez jamais ce distributeur avec une eau qui n'est peut-être pas potable ou qui provient d'une source inconnue.
4. N'employez jamais dans le distributeur d'autres liquides que de l'eau en bouteille connue et microbiologiquement sûre.
5. Ce distributeur d'eau a une prise d'alimentation électrique avec mise à la terre pour assurer votre sécurité.
6. Conservez votre distributeur d'eau à un endroit sec et non exposé aux rayons solaires directs.
7. Laissez au moins 2 po (5 centimètres) derrière le distributeur et sur les côtés pour avoir une ventilation appropriée.
8. Installez toujours le distributeur d'eau sur une surface au niveau qui peut soutenir tout son poids.
9. Débranchez toujours le distributeur d'eau avant d'en faire l'entretien.
10. Un nettoyage régulier de votre distributeur d'eau est nécessaire pour que la garantie soit applicable. Veuillez suivre les instructions de nettoyage de ce manuel et nettoyer le distributeur tous les 4 mois.

# Pré-Opération

## PRÉCAUTIONS DE MISE À LA TERRE

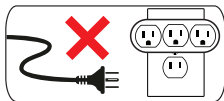
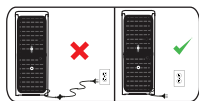
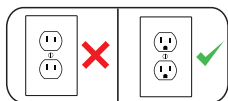

## AVERTISSEMENTS

### EXIGENCES ÉLECTRIQUES :

Une alimentation électrique mise à la terre de 115 V/60 Hz, CA, à 15 ampères seulement, avec fusible est nécessaire. Il est recommandé de prévoir un circuit distinct pour alimenter uniquement votre distributeur d'eau. Utilisez une prise qui ne peut pas être désactivée par un interrupteur.



## AVERTISSEMENTS

**LE NON-RESPECT DE CES INSTRUCTIONS PEUT ENTRAÎNER LA MORT, UN INCENDIE OU UN CHOC ÉLECTRIQUE**

### INSTRUCTIONS DE MISE À LA TERRE:

- **Avvertissement :** Cet appareil doit être mis à la terre. En cas de court-circuit, la mise à la terre réduit les risques de chocs électriques en procurant un chemin d'évacuation du courant.
- **Avvertissement :** Une utilisation inadéquate de la fiche de mise à la terre peut entraîner des chocs électriques, pouvant ainsi causer des blessures graves, voire la mort.
- **Avvertissement :** Cet appareil est doté d'un cordon d'alimentation muni d'un conducteur de mise à la terre et d'une fiche mise à la terre, et doit être raccordé à une prise polarisée correctement mise à la terre. Faites appel à un électricien qualifié si vous ne comprenez pas parfaitement les instructions de mise à la terre ou si vous avez des doutes sur la mise à la terre adéquate de votre appareil.
- **Avvertissement :** Si la prise de courant murale est une prise standard à deux broches, il vous incombe de la remplacer par une prise à trois broches mise à la terre de façon adéquate.
- **Avvertissement :** Ne coupez et ne retirez jamais la broche de mise à la terre du cordon d'alimentation.
- **Avvertissement :** N'utilisez pas d'adaptateurs ou de rallonges avec cet appareil.
- **Avvertissement :** Si le cordon d'alimentation est trop court, demandez à un électricien qualifié d'installer une prise de courant à proximité de l'appareil.
- **Avvertissement :** N'utilisez PAS l'appareil si le cordon d'alimentation est effiloché ou endommagé.

## FICHE TECHNIQUE

Model No.	VWD2265W
Dimensions L x P x H	11.4 po. x 11.8 po. x 33.9 po. • 29cm x 30cm x 86cm
Poids Net / Poids Brut	23.1 lbs / 27.5 lbs • 10.5 kg / 12.5 kg
Température de refroidissement (env.):	39 °F / 3.8 °C
	<b>Froid</b>
Consommation d'électricité	80W

# Garantie

NE PAS RETOURNER CE SYSTÈME AU MAGASIN: Veuillez joindre le Service à la clientèle au 1-877-447-4768.

Le fournisseur garantit votre distributeur d'eau pour les vices de fabrication lorsque le produit fonctionne dans des conditions normales pendant un (1) an à compter de la date d'achat originale. Cette garantie s'applique seulement dans le pays dans lequel le produit est vendu et est valable pour l'acheteur d'origine seulement. Cette garantie est non négociable.

Cette garantie et le référencement CSA International concernant ce distributeur d'eau deviendront nuls si le distributeur d'eau est altéré, modifié ou combiné avec toute autre machine ou appareil. Une altération de ce distributeur d'eau peut causer des inondations graves et/ou un grave danger de choc électrique ou d'incendie.

Les dispositions de cette garantie ne s'appliqueront pas à :

- Bouteilles d'eau.
- Trajets des interventions à votre domicile pour vous apprendre à utiliser le produit.
- Mauvaise installation, livraison, ou entretien (le non-respect de l'entretien du produit conformément aux instructions du manuel du produit annulera automatiquement la garantie).
- Défaillance du produit en cas de mauvais usage, modification, usage commercial ou usage à des fins autres que l'utilisation prévue.
- Produits utilisés à l'extérieur de l'environnement résidentiel ou du bureau.
- Remplacement des fusibles du domicile ou réamorçage des disjoncteurs.
- Utilisation de ce produit avec de l'eau microbiologiquement dangereuse ou de qualité inconnue.
- Dommages causés au produit en cas d'utilisation pour la distribution autre que celle de l'eau.
- Dommages causés au produit par accident, incendie, inondations ou actes de Dieu.
- Tout service au produit par un personnel non autorisé.
- Dommages indirects ou fortuits découlant de possibles vices de cet appareil, de son installation ou de sa réparation.

Cette garantie devra être exécutée dans un établissement de réparation autorisé. Toutes les réparations sous garantie doivent être autorisées au préalable par le fournisseur. Le fournisseur choisira à sa discrétion de réparer ou remplacer gratuitement toute pièce défectueuse lorsque l'Acheteur aura informé son revendeur durant la période garantie. L'obligation de le fournisseur sous cette garantie se limite expressément à ces réparations ou remplacements.



# Garantie

Cette garantie ne couvre pas les frais de transport vers l'établissement de réparation autorisé, ni pour le retour.

À l'exception des conditions définies ci-après ou exigées par la loi, le Fabricant n'engage aucune autre garantie, ou acceptation expresse, implicite ou garantie par la loi incluant toute garantie implicite de qualité marchande ou de condition d'usage particulier. Le Fabricant n'assume pas et n'autorise personne à assumer des obligations de responsabilité en rapport avec ce distributeur d'eau. En aucun cas le fabricant ne pourra être tenu responsable des dommages indirects, particuliers ou fortuits (y compris, sans limitations, pour des préjudices financiers) ou des délais dus à des causes indépendantes de sa volonté lors de l'exécution de cet accord.

Certains États ou provinces n'appliquent pas de limitations concernant la durée de la garantie implicite, de sorte que la limitation énoncée ci-dessus peut ne pas s'appliquer dans votre cas. Certains États ou provinces n'autorisent pas l'exclusion ou la limitation de dommages fortuits ou indirects, de sorte que les limitations et exclusions énoncées ci-dessus peuvent ne pas s'appliquer dans votre cas. Cette garantie vous confère des droits juridiques spécifiques; vous pouvez également bénéficier d'autres droits qui peuvent varier d'un État à l'autre ou d'une province à l'autre.

Si vous avez besoin de service, voir d'abord la section "Dépannage" de ce manuel. De l'aide supplémentaire peut être trouvée en appelant notre service à la clientèle au 1-877-447-4768.

***Conservez ce manuel et votre reçu de vente pour référence ultérieure. Vous devez présenter une preuve d'achat pour le service sous garantie.***

Inscrivez les renseignements suivants au sujet de votre rafraîchisseur d'eau pour mieux vous aider à obtenir assistance ou service en cas de besoin. Vous devrez connaître le numéro de modèle et le numéro de série au complet. Vous trouverez cette information à l'arrière du distributeur d'eau.

# Pré-Opération (suite)

## CONTENU DE LA TROUSSE

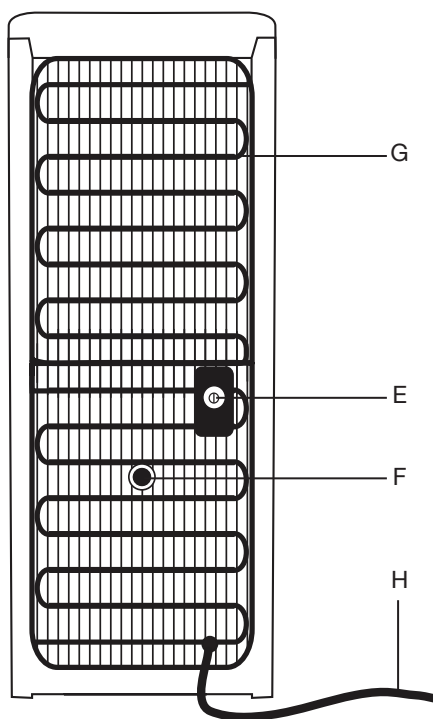
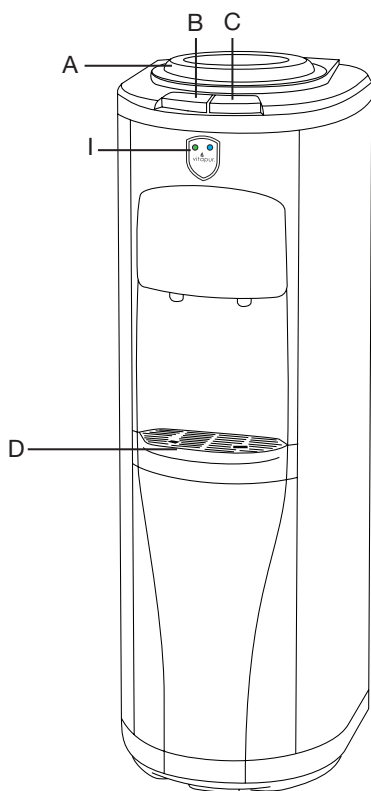

Pièce	Description	Qté
A	Collier de soutien de la bouteille	1
B	Bouton de distribution d'eau ambiante	1
C	Bouton de distribution d'eau froide	1
D	Plateau égouttoir amovible	1

Pièce	Description	Qté
E	Thermostat réglable d'eau froide	1
F	Vanne de vidange	1
G	Serpentin du condenseur	1
H	Cordon d'électricité	1
I	Prêt-à distribuer voyants (Vert = L'appareil est sous tension) (Bleu = Eau froide prête)	2

# Pré-Opération (suite)

## NETTOYAGE INITIAL DE PRODUIT

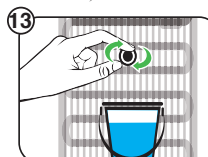
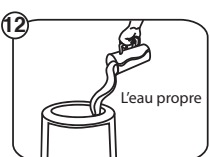
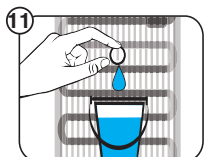
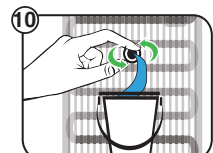
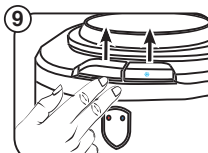
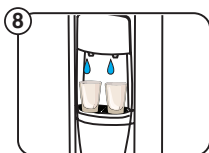
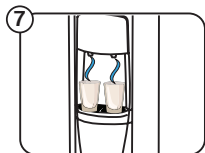
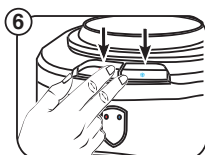
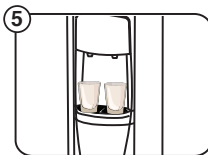
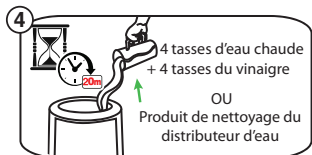
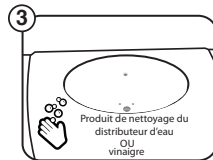
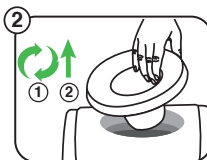
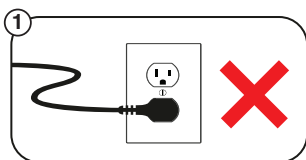

## INSTALLATION DE LA BOUTEILLE DE L'EAU

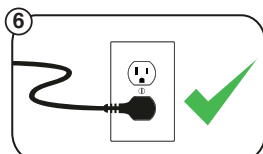
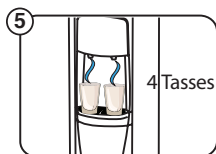
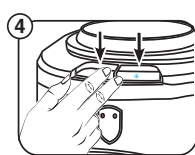
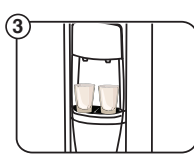
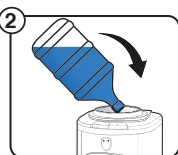
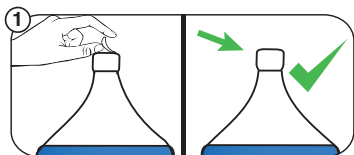
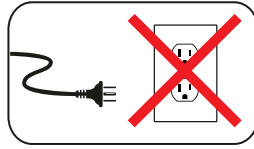
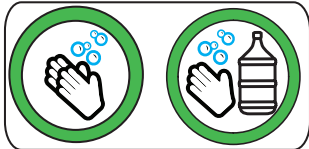

# Opération

## 1. DISTRIBUTION DE L'EAU FROIDE

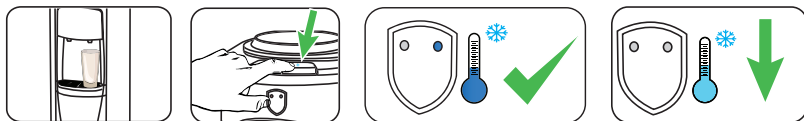

## 2. DISTRIBUTION D'EAU AMBIENTE



## 3. RÉGLAGE DE LA TEMPÉRATURE (EAU FROIDE SEULEMENT)

◇ En tournant le thermostat à l'arrière de l'unité, la température peut être ajustée. Tourner le cadran entre le "MIN" et "MAX" jusqu'à la température désirée est atteints. Tourner le bouton de commande vers la droite pour la température plus froide. Tourner le bouton de commande vers la gauche pour la température plus chaude.

**Remarque:** Si l'eau ne coule pas, il est possible que l'orifice soit bouché par de la glace qui s'est formée parce que le thermostat est réglé trop haut. Si c'est le cas, débranchez le distributeur pendant la nuit et rebranchez-le le matin. Réglez le thermostat à haut, et augmentez progressivement ce réglage, en fonction de vos besoins en matière d'eau froide.

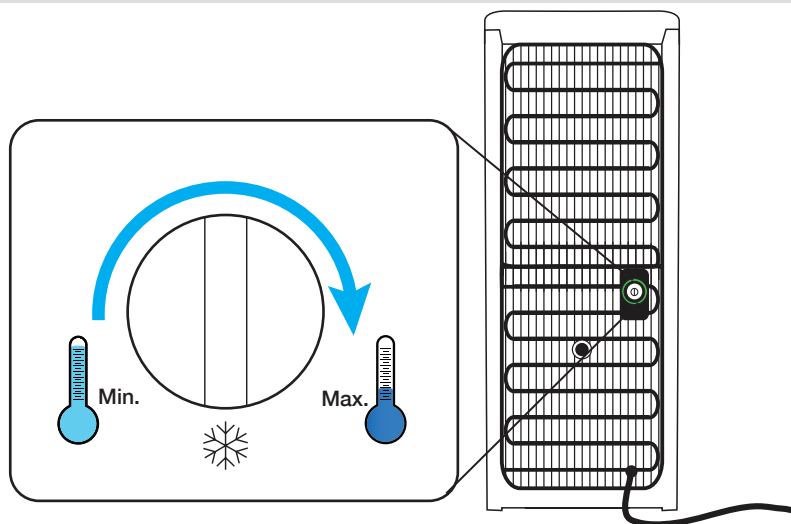

# Contenu de la trousse

## NETTOYAGE DE L'EXTÉRIEUR DU DISTRIBUTEUR D'EAU

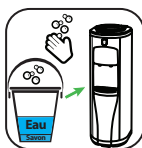
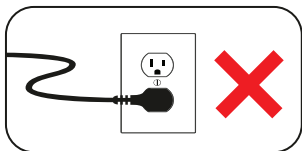

## NETTOYAGE DU BAC

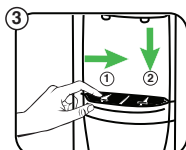
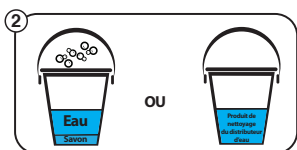

## NETTOYAGE DU CONDENSATEUR

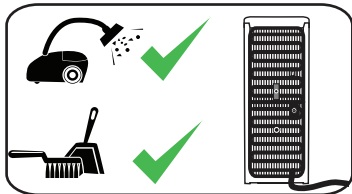

## VIDANGE DES RÉSERVOIRS

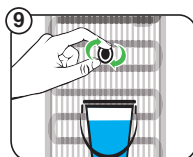
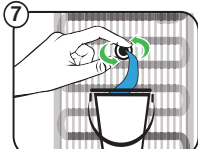
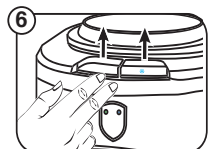
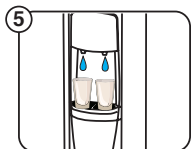
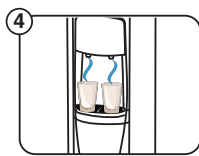
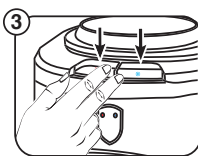
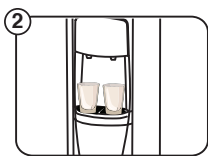
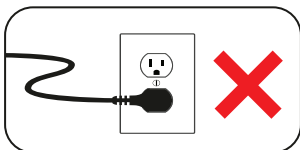

# NETTOYAGE DE L'INTÉRIEUR DU DISTRIBUTEUR

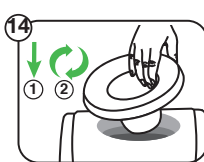
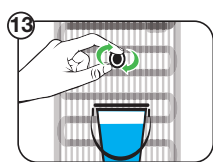
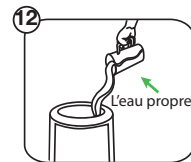
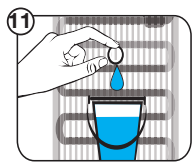
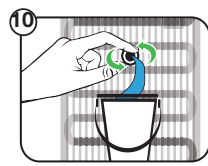
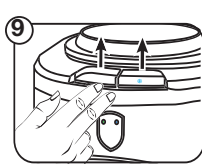
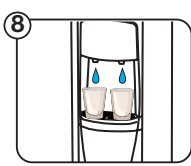
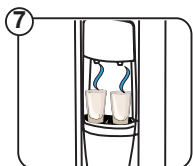
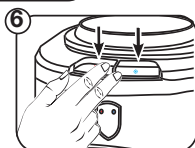
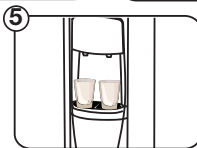
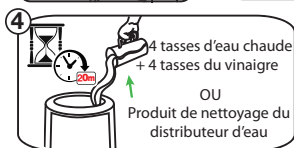
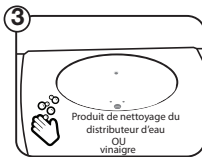
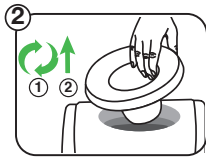
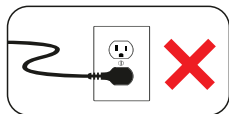

## VACANCES

Si vous n'utilisez pas le distributeur d'eau pendant de longues périodes, ou si vous partez en vacances, vous pouvez économiser de l'électricité, débranchez le distributeur et videz les réservoirs. (Voir vidange des réservoirs). À votre retour, suivez les étapes du nettoyage initial et remettez votre distributeur en marche.

## QUESTIONS FRÉQUEMMENT POSÉES

**Q: Pourquoi y a-t-il un goût en plastique de mon distributeur ?**

A: Comme avec la plupart des nouveaux appareils, comme les cafetières et les bouilloires, il y a souvent un goût de plastique au moment de la mise en service initiale de l'appareil. Pour enlever ce goût, suivez simplement les instructions décrites pour le Nettoyage de l'intérieur du distributeur.

**Q: Quelle est la pointe qui entre dans la bouteille?**

A: Les distributeurs d'eau Vitapur® sont pourvus d'une pointe perceuse dans le joint de bouteille, facilitant ainsi l'installation des bouteilles d'eau. Selon le distributeur de bouteilles d'eau, certaines bouteilles sont équipées d'une membrane perforable incorporée au bouchon de la bouteille (demandez à votre distributeur si ses bouteilles d'eau sont pourvues de cette caractéristique). Si vos bouteilles d'eau ne sont pas dotées de cette membrane, vous devez retirer le bouchon afin d'éviter d'endommager la pointe perceuse.

# Conseils de Dépannage

Problème	Cause possible	Solution Suggérée
Le distributeur d'eau coule	Le capuchon de vidange et le joint étanche à la silicone ne sont pas sûrs.	Ensure seal is secure in drain plug and tighten drain cap.
	L'eau a été versée directement dans le collier de soutien de la bouteille et elle a débordé.	Vidangez le distributeur en appuyant sur les boutons de distribution.
L'eau n'est pas assez froide	Toute l'eau dans le réservoir a été utilisée.	Remplacez avec une bouteille pleine et attendre 30 minutes pour que l'eau refroidisse.
	L'appareil est débranché.	Branchez l'appareil dans une prise.
	Le disjoncteur de votre maison est déclenché ou le fusible a grillé.	Réarmez le disjoncteur ou remplacez le fusible.
	Le thermostat doit être réglé à une température plus froide.	Réglez le thermostat entre «MIN» (frais) et «MAX» (froid) jusqu'à ce que vous parveniez à la température désirée.
Le distributeur d'eau ne distribue pas d'eau	Bouteille d'eau est vide.	Remplacez la bouteille d'eau.
	Des dépôts de minéraux obstruent les réservoirs.	Voyez les instructions sur le Nettoyage des réservoirs.
	Possible poche d'air.	Appuyez sur les robinets pour amorcer l'appareil.
	Accumulation de glace due à une température trop froide.	Débranchez l'appareil pendant la nuit et rebranchez-le le matin. Réglez le thermostat à une température basse, et augmentez progressivement ce réglage en fonction de vos besoins.
Le distributeur d'eau est bruyant	La bouteille fait un bruit de glouglou quand je remplis le réservoir.	C'est normal.
	La distribution d'eau est inégale.	Assurez-vous que le distributeur est placé sur une surface au niveau qui peut soutenir tout son poids.

**Remarque :** Ne pas retourner ce produit au magasin. Pour des questions sur le fonctionnement, l'assemblage ou les pièces, s'il vous plaît communiquer avec le service à la clientèle au 1-877-447-4768 pour plus d'assistance.

# COLLIER DE SOUTIEN DE BOUTEILLE ANTI-FUITE

Le collier de soutien de la bouteille sur votre distributeur d'eau est conçu avec un système spéciale anti-fuite pour éviter la perte accidentelle d'eau, (inondations) à la suite de l'installation par inadvertance, une bouteille d'eau défectueuse. Malheureusement, toutes les bouteilles d'eau sont créées égaux. Presque tous les 3, 4 et 5 gallons (12, 15 et 19 litres) bouteilles d'eau sont recyclées et traitées intensivement pendant le nettoyage, le remplissage et l'expédition. En conséquence, ils sont très vulnérables aux fractures en développement et les fuites sténopé qui ne sont pas toujours évidents à l'utilisateur final jusqu'au moment de l'installation.

**Important:** Ne jamais installez une bouteille d'eau défectueuse sur un distributeur d'eau. Retournez la bouteille immédiatement pour un remplacement. En cas de fuite d'eau, ce simple test vous permettra d'établir si la bouteille d'eau ou le distributeur est à la source du problème.

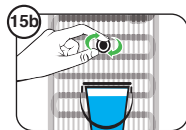
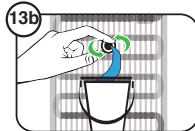
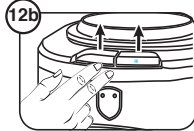
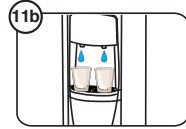
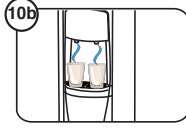
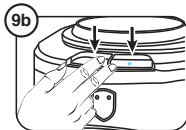
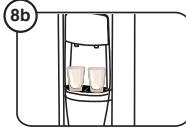
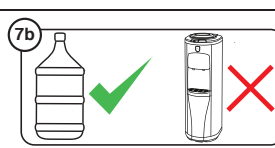
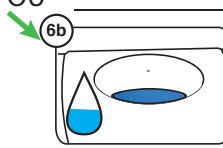
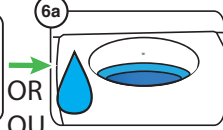
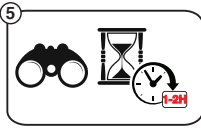
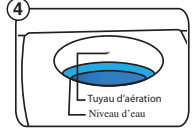
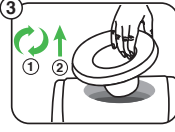
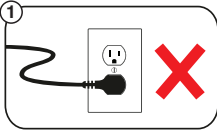

16b



1-877-447-4768

SERVICE A LA CLIENTELE





Modelo #VWD2265W

## Dosificador de agua de Alta Eficiencia con Montaje

### Manual de uso y cuidado



**¿Preguntas, problemas, piezas faltantes?**

**Antes de regresar a la tienda, por favor llame al servicio de atención al cliente de GHP Group al número gratuito 1-877-447-4768 entre las 8 a.m. y 4:30 p.m., HEC, de lunes a viernes.**

**POR FAVOR LEA ESTE MANUAL CUIDADOSAMENTE ANTES DE UTILIZAR EL ELECTRODOMÉSTICO Y CONSÉRVELO PARA FUTURA REFERENCIA**

### **GRACIAS**

**Agradecemos la confianza que ha depositado en GHP Group a través de la compra de este enfriador de agua. Nos esforzamos continuamente por crear productos de calidad diseñados para mejorar su hogar. Visítenos en línea para ver nuestra línea completa de productos disponibles para sus necesidades de mejoras para el hogar. Visite nuestra página web para ver nuestra línea completa de productos disponibles para su hogar, en [www.ghpgroupinc.com](http://www.ghpgroupinc.com). Gracias por elegir VitaPur!**

# Información de seguridad



**Advertencia:** Nunca ponga nada inflamable cerca del dosificador.



**Advertencia:** Este dispensador de agua está diseñado para uso en interiores solamente.



**Advertencia:** No dañar el sistema de refrigeración.



**Advertencia:** Este producto puede exponerlo a usted a agentes químicos incluyendo ftalato de diisononilo (DINP), reconocido por el estado de California como causante de cáncer, así como ftalatos de diisodocilo (DIDP), reconocidos por el estado de California como causantes de defectos congénitos y otros daños al sistema reproductor.

**Para obtener más información, visite [www.p65Warnings.ca.gov](http://www.p65Warnings.ca.gov)**



**Importante:** Los refrigerantes deben ser manejados y eliminados por el personal de servicio calificado. Antes de desechar el dispensador de agua a los vertederos, póngase en contacto con las autoridades locales para el asesoramiento sobre los métodos de eliminación adecuados para refrigerantes.

1. No ponga nunca el dosificador boca abajo ni lo incline más de 45 grados. Si la unidad ha estado apoyada sobre un costado durante un periodo prolongado de tiempo, coloque el dosificador de agua en la posición vertical durante aproximadamente 12 horas antes de encenderlo.
2. Para el uso con botellones de agua de 3, 4 ó 5 galones (12, 15 ó 19 litros).
3. Nunca use este dosificador con agua que es insegura para beber o que proviene de una fuente desconocida.
4. Nunca use ningún otro líquido en el dosificador, salvo el agua embotellada conocida y microbiológicamente segura.
5. Para su seguridad, este dosificador de agua está equipado con un cable de alimentación conectado a tierra.
6. Conserve su dosificador de agua en un lugar seco y alejado de la luz del sol directa.
7. Deje un mínimo de 2" (5 cm) alrededor de la parte trasera y los lados del dosificador para una ventilación apropiada.
8. Siempre instale el dosificador de agua sobre una superficie plana y que pueda soportar todo su peso.
9. Siempre desenchufe el dosificador de agua antes de darle servicio.
10. Se necesita una limpieza periódica del dosificador de agua para la garantía. Siga las instrucciones de limpieza señaladas en este manual, y limpie el dosificador cada 4 meses.

# Pre-Operación

## PRECAUCIONES DE PUESTA A TIERRA

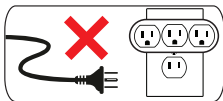
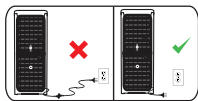
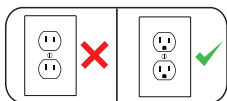

## ADVERTENCIA

### REQUERIMIENTOS ELÉCTRICOS:

Se requiere de una alimentación eléctrica con toma a tierra de 115 V/60Hz, CA, solamente de 15 amperios, con fusible. Se recomienda que se provea un circuito separado para alimentar su dispensador de agua exclusivamente. Utilice un enchufe que no pueda ser desactivado a través de un interruptor.



## ADVERTENCIA

**EL INCUMPLIMIENTO DE ESTAS INSTRUCCIONES PUEDE OCASIONAR LA MUERTE, INCENDIO O DESCARGA ELÉCTRICA**

### INSTRUCCIONES DE PUESTA A TIERRA:

- **Advertencia:** El presente electrodoméstico debe estar conectado a tierra. En caso de cortocircuito, la conexión de puesta a tierra disminuye el riesgo de descargas eléctricas ya que tiene un cable de escape para la corriente eléctrica.
- **Advertencia:** El uso inadecuado de la conexión de puesta a tierra puede traer aparejadas descargas eléctricas, causar lesiones e incluso la muerte.
- **Advertencia:** El presente electrodoméstico tiene un cable de alimentación que cuenta con un enchufe de puesta a tierra y debe estar conectado a un tomacorriente polarizado con la puesta a tierra correspondiente. Consulte a un electricista calificado si no comprende, en su totalidad, las instrucciones de conexión de puesta a tierra, o si tiene dudas acerca de la conexión a tierra del electrodoméstico.
- **Advertencia:** Si el tomacorriente es de 2 patas, es su responsabilidad y obligación cambiarlo por uno de 3 patas debidamente puesto a tierra.
- **Advertencia:** Bajo ninguna circunstancia corte o retire la tercera pata (de conexión a tierra) del cable de alimentación.
- **Advertencia:** No utilice adaptadores o cables alargadores con este aparato.
- **Advertencia:** Si el cable de alimentación es demasiado corto, pídale a un electricista calificado que instale un tomacorriente cerca del electrodoméstico.
- **Advertencia:** NO utilice el aparato si el cable de alimentación eléctrica está pelado o dañado.

## ESPECIFICACIONES

Modelo	VWD2265W
Dimensiones A x P x A	11.4 in. x 11.8 in. x 33.9 in. • 29cm x 30cm x 86cm
Peso Neto / Peso Bruto	23.1 lbs / 27.5 lbs • 10.5 kg / 12.5 kg
Temperatura de enfriamiento (aprox.):	39 °F / 3.8 °C
	Fría
Consumo de energía:	80W

# Garantía

No devuelva este producto a la tienda : Por favor contacte Servicio al Cliente al 1-877-447-4768.

El proveedor garantiza que su dispensador de agua está libre de defectos de fabricación en materiales o mano de obra bajo condiciones de uso normales durante un (1) año a partir de la fecha original de compra. Esta garantía sólo se aplica en el país en que se vende, y está disponible para el comprador original. Esta garantía no es transferible.

Esta garantía y la lista de CSA International para el dispensador de agua se anula si el dispensador de agua es alterado, modificado o combinado con cualquier otro equipo o dispositivo. La alteración de este dispensador de agua puede causar inundaciones graves y / o una descarga eléctrica peligrosa o un incendio.

Las disposiciones de esta garantía no se aplicarán a:

- Botellas de agua.
- Viajes de servicio a su casa para enseñarle cómo usar el producto.
- La instalación, entrega o mantenimiento (Falta de mantenimiento del producto de acuerdo con las instrucciones descritas en el manual del producto automáticamente anulará la garantía).
- Fallas del producto debido a abuso, mal uso, alteración, uso comercial, o uso para otros propósitos que los propuestos.
- Productos que se utilizan fuera de un entorno residencial o de oficina.
- Reemplazo de fusibles de su hogar o reajuste de interruptores de circuito.
- El uso de este producto donde el agua sea microbiológicamente insegura o de calidad desconocida.
- Los daños al producto si se utiliza para dispensar cualquier cosa que no sea agua.
- Daños al producto causados por accidentes, incendios, inundaciones o actos de Dios.
- Cualquier servicio al producto por personal no autorizado.
- Daño incidental o consecuencial causado por posibles defectos con este electrodoméstico, su instalación o reparación.

Esta garantía se cumplirá en un centro de reparación autorizado. Todas las reparaciones deberán ser autorizadas previamente por el proveedor. El proveedor, a su opción, reparará o reemplazará gratuitamente cualquier pieza defectuosa, que el comprador haya notificado su distribuidor dentro del período de garantía. La obligación del proveedor bajo esta garantía se limita expresamente a la reparación o sustitución. Esta garantía no cubre los costos de transporte hacia y desde el centro de reparación autorizado.

# Garantía

Excepto como se establece en este documento o requerido por la ley, el fabricante no hace ninguna otra garantía o acuerdo, expresa, implícita o legal incluyendo cualquier garantía implícita de comerciabilidad o aptitud para un propósito en particular. El fabricante no asume ni autoriza a nadie a asumir ninguna obligación de responsabilidad en relación con este dispensador de agua. En ningún caso el fabricante será responsable por daños indirectos, especiales o consecuentes (incluyendo, sin limitación, la pérdida económica) o por cualquier retraso en el cumplimiento de este acuerdo por causas ajenas a su control.

Algunos estados o provincias no permiten limitaciones en la duración de una garantía implícita, por lo que la limitación anterior puede no aplicarse en su caso. Algunos estados o provincias no permiten la exclusión o limitación de daños incidentales o consecuentes, por lo que la limitación o exclusión anterior puede no aplicarse en su caso. Esta garantía le otorga derechos legales específicos, y usted también puede tener otros derechos que varían de estado a estado o de provincia a provincia.

Si requiere servicio, por favor, primero vea la sección “Solución de problemas” de este manual. Asistencia adicional se puede encontrar llamando a nuestra línea de servicio al cliente al 1-877-447-4768.

***Guarde este manual y su comprobante de compra juntos para referencia futura. Debe proporcionar una prueba de compra para obtener servicio bajo garantía.***

Escriba el número de modelo completo y el número de serie de su enfriador de agua para ayudarle mejor a obtener asistencia o servicio técnico si alguna vez usted lo necesita. Usted puede encontrar esta información en la parte posterior del dispensador de agua.

# Pre-Operación (continuación)

## CONTENIDO DEL PAQUETE

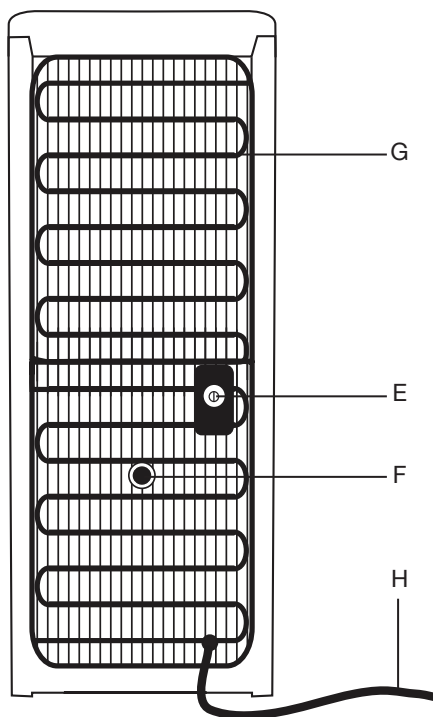
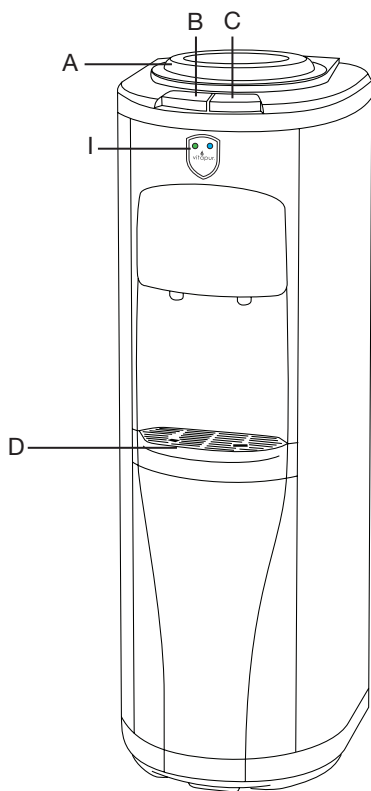

Parte	Descripción	Cant.
A	Collar de soporte de la botella	1
B	Botón distribuidor de agua caliente	1
C	Botón distribuidor de agua fría	1
D	Bandeja removible para goteo de agua	1

Parte	Descripción	Cant.
E	Termostato ajustable para el agua fría	1
F	Válvula de drenaje	1
G	Condensador	1
H	Cable eléctrico	1
I	Listos para dispensar Luces indicadoras (Verde = en el poder) (Azul = agua fría listo)	2

# Pre-Operación (continuación)

## PROCEDIMIENTO INICIAL DE LIMPIEZA DEL PRODUCTO

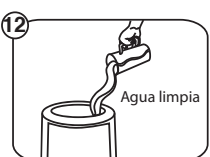
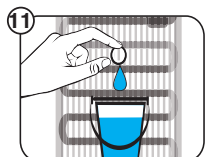
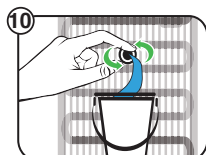
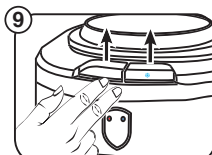
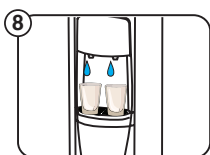
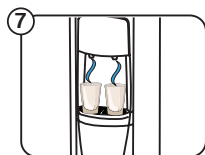
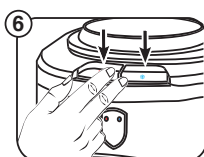
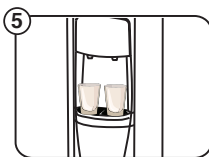
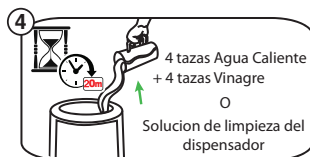
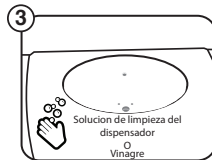
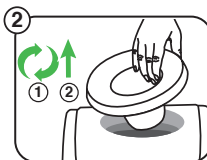
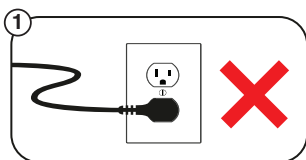

## CÓMO INSTALAR EL BOTELLÓN DE AGUA

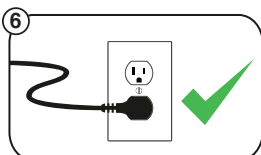
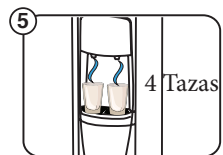
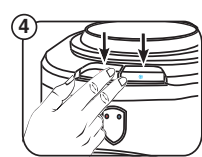
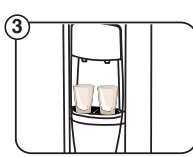
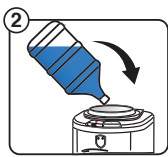
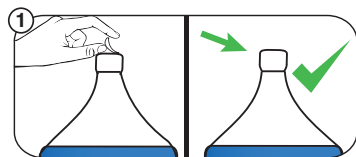
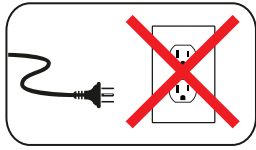
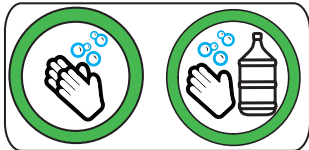

# Operación

## 1. SURTE AGUA A TEMPERATURA FRÍA

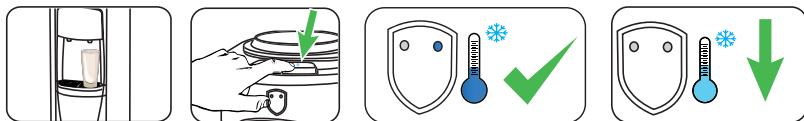

## 2. CÓMO SURTIR AGUA A TEMPERATURA AMBIENTE



## 3. CÓMO REGULAR LA TEMPERATURA (SÓLO PARA AGUA FRÍA)

- ◇ La temperatura puede regularse girando el termostato que está en la parte trasera de la unidad. Gire el cuadrante en el sentido de las manecillas del reloj, entre los niveles alto (fresca) y bajo (más fría) hasta alcanzar la temperatura deseada.

**Nota:** Si el dosificador de agua no despacha agua, es posible que haya una acumulación de hielo debido a que el termostato está fijado en una posición demasiado fría. Si esto sucede, desenchufe durante la noche, luego reposicione. Coloque el termostato en alto, y aumente lentamente según el uso y la necesidad de tener agua fría.

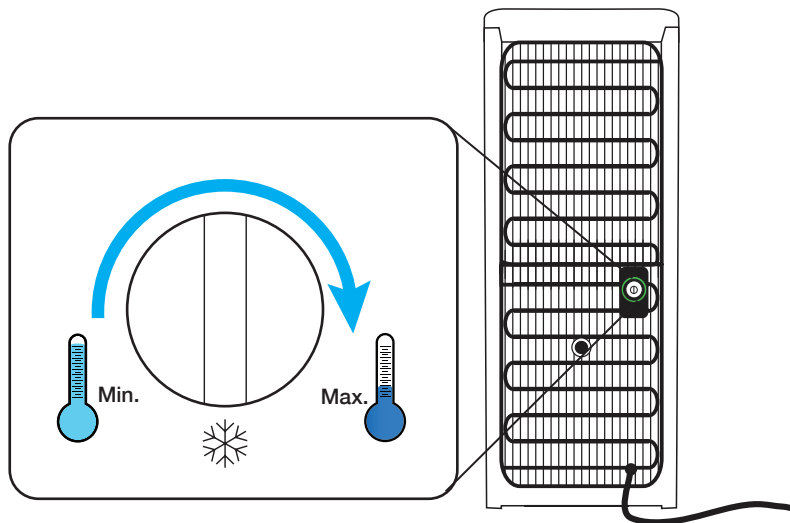



# Cuidado y Limpieza

## LA LIMPIEZA DEL EXTERIOR DEL DOSIFICADOR DE AGUA

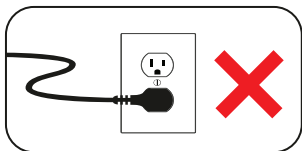

## CÓMO LIMPIAR LA BANDEJA DE GOTEO

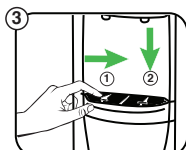
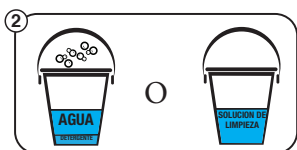

## LIMPIEZA DEL CONDENSADOR

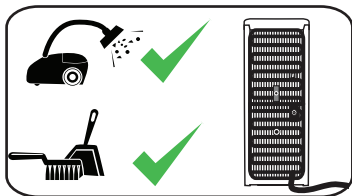

## DESAGÜE DE LOS DEPÓSITOS

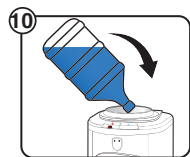
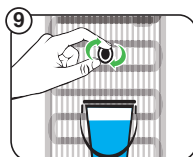
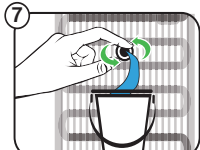
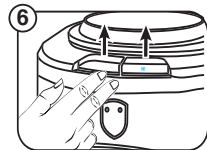
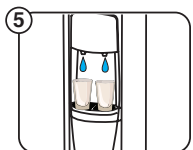
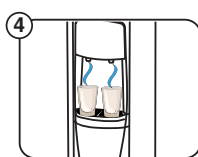
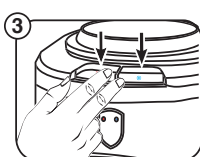
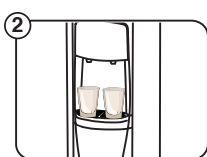
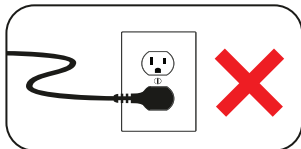

## LIMPIEZA DEL INTERIOR DEL DOSIFICADOR

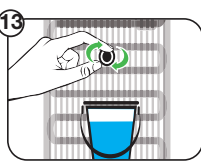
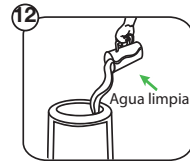
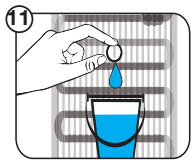
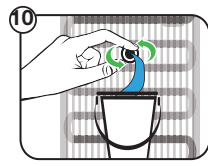
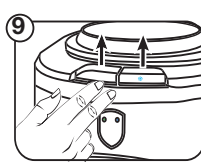
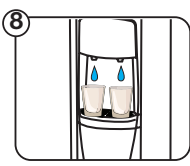
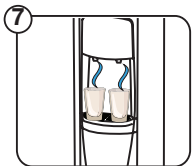
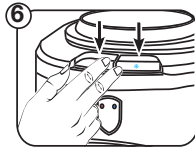
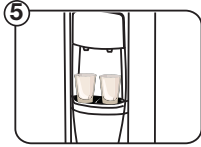
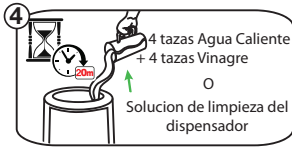
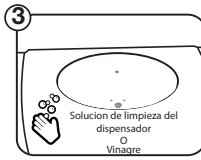
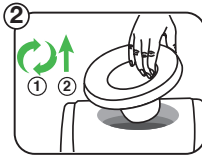
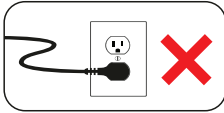

## SI SALE DE VACACIONES

Cuando no use el dosificador por períodos de tiempo prolongados o cuando esté de vacaciones, conserve la energía, desenchufe el dosificador y vacíe los depósitos (vea Desagüe de los depósitos). Cuando regrese, siga los procedimientos de limpieza y puesta en marcha inicial del dosificador.

## PREGUNTAS MÁS FRECUENTES

**Q: ¿Por qué el agua de mi dosificador tiene un sabor a plástico?**

**A:** Como con la mayoría de los aparatos más nuevos como cafeteras y teteras, hay a menudo un sabor a plástico al poner en marcha la unidad por primera vez. Para eliminar este sabor, implemente siga las instrucciones de Limpieza del interior del dosificador.

**Q: Quelle est la pointe qui entre dans la bouteille?**

**A:** Los dispensadores de agua Vitapur® cuentan con una "válvula de perforación" como parte del collarín de soporte del botellón, que facilita la instalación del botellón de agua. Según el proveedor de botellones de agua, algunos botellones incluyen una membrana de auto-perforación en la tapa del botellón para ese fin específico (consulte a su proveedor de botellones, si su botellón incluye esta característica). Si la tapa del botellón de agua no tiene esa abertura, deberá retirar toda la tapa para prevenir un daño posible a la válvula de perforación.

## Consejos de Localización y Reparación de Averías

Problema	Causa Posible	Solución Sugerida
El dosificador de agua está goteando	La tapa del desagüe y el sello de silicona no están bien asegurados.	Asegúrese de que el sello de la tapa del desagüe está bien asegurado y apriete la tapa del desagüe.
	Se vertió el agua directamente en el collarín de soporte del botellón y se desbordó.	Desagüe presionando los grifos del dosificador.
El agua no está suficientemente fría	Se usó toda el agua en el tanque.	Reemplace con un botellón lleno; espere 30 minutos para que el agua se enfríe.
	La unidad está desenchufada.	Enchúfela en el tomacorriente.
	Se disparó un disyuntor o se voló un fusible en su casa.	Restaure el disyuntor o reemplace el fusible.
	Debe regularse el termostato para que quede más frío.	Regule el termostato entre los niveles "MIN" (fresco) y "MAX" (más frío) para alcanzar la temperatura deseada.
El dosificador de agua no surte agua	El botellón de agua está vacío.	Reemplazar con un botellón lleno.
	Hay acumulación de minerales que está obstruyendo los tanques.	Véase Cómo limpiar los depósitos.
	Posible burbuja de aire.	Presione los grifos del dosificador para cebar la unidad.
	Posible acumulación de hielo debido a que el en una posición reposicione.	Desenchufe durante la noche, luego termostato está fijado Coloque el termostato en alto, demasiado fría. y aumente lentamente según el uso y la necesidad de tener agua fría.
El dosificador de agua hace ruidos	El botellón hace un ruido como de gorjeo cuando se está llenando el tanque.	Esto es normal.
	El dosificador de agua está desnivelado.	Cerciórese de que el dosificador está sobre una superficie plana y que pueda soportar todo su peso.

**Nota:** No devuelva este producto a la tienda. Si tiene preguntas sobre el funcionamiento, montaje o piezas, por favor póngase en contacto con nosotros al 1-877-447-4768.

# COLLAR DE SOPORTE DE BOTELLA A PRUEBA DE FUGAS DE AGUA

El collar de soporte de botella de su dispensador de agua, está diseñado con un sistema especial de prevención contra las fugas de agua para evitar la pérdida accidental de agua (inundaciones), como consecuencia del descuido de instalar una botella de agua defectuosa. Lamentablemente, no todas las botellas de agua son creadas igualmente. Casi todas las botellas de agua de 3, 4 y 5 galones (12, 15 y 19 litros) son recicladas y manipuladas en exceso durante la limpieza, el llenado y el envío. Como resultado, son muy propensas a desarrollar cuarteados bien finos y pequeños agujeros con escape de agua que no siempre son evidentes para el usuario final hasta el momento de la instalación.



**Importante:** Nunca instale una botella de agua en un dispensador de agua a sabiendas de que esta defectuosa. Regrésela inmediatamente para su reemplazo. Si hay pérdidas, esta simple prueba le permitirá determinar si la causa del problema es la botella de agua o el dosificador.

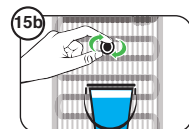
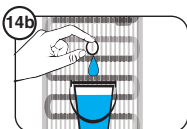
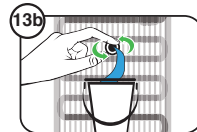
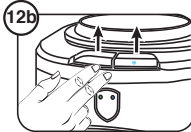
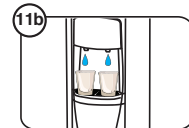
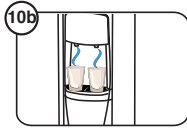
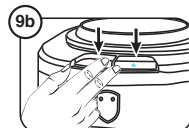
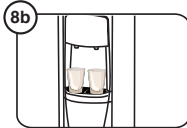
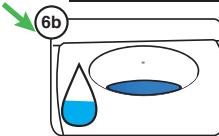
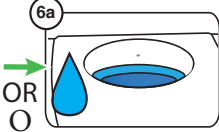
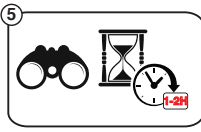
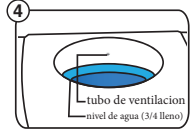
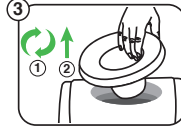
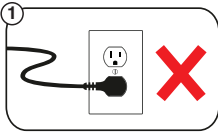

16b



1-877-447-4768  
SERVICIO AL CLIENTE