



AZEK Trim & Moulding Install Guide

Storage & Handling, Cutting, Drilling, Routing	2
Fastening, Expansion & Contraction	3
Painting, Gluing	4
Spanning, Water Table	5
Garage Door Thermostop, Rabbeted Cornerboard	6
Universal Skirt Board, Integrated Drip Edge	7
Installing Finish Grade Trim	8
Notes.....	10

- These guidelines cover the general installation recommendations for AZEK Trim and AZEK Moulding. See specific installation information for Universal Skirt Board, Integrated Drip Edge, Rabbeted Cornerboard, Column Wrap, Finish Grade Trim, Water Table, and Garage Door Thermostop.
- AZEK Trim and AZEK Mouldings should be installed using the same good building principles used to install wood trim and mouldings and in accordance with the local building codes and the installation guidelines included below. AZEK Building Products Inc. accepts no liability or responsibility for the improper installation of this product.
- AZEK Trim and AZEK Moulding may not be suitable for every application and it is the sole responsibility of the installer to be sure that AZEK Trim and Mouldings are fit for the intended use. Since all installations are unique, it is also the installer’s responsibility to determine specific requirements in regards to each trim and moulding application.
- AZEK Building Products recommends that all applications be reviewed by a licensed architect, engineer or local building official before installation. If you have any questions or need further assistance, please call AZEK Customer Service at 877-ASK-AZEK (877-275-2935) or visit our website at www.azek.com.

STORAGE & HANDLING

- Store AZEK Trim and Moulding products on a flat and level surface.
- Since AZEK Trim and Moulding products are more flexible than wood, they may conform to uneven surfaces. Ensure that storage areas, as well as all framing and substructures, are flat and level to minimize uneven surfaces.
- AZEK Trim and Moulding products have a density comparable to pine and should be handled in a fashion as pine would be handled to avoid damage.
- Units of AZEK Trim and Moulding products are shipped from the manufacturer in a protective covering. If covering has been removed, take care to keep product free of dirt and debris at jobsite. If product gets dirty, clean after installation.
- Care should be taken in handling the individually wrapped column wraps to prevent tearing of tape or cracking at miter lock corner joints.

CUTTING

- AZEK Trim and Moulding products can be cut using the same tools used to cut lumber.
- Carbide tipped blades designed to cut wood work well. Avoid using fine tooth metal cutting blades.
- Rough edges from cutting may be caused by excessive friction, poor board support, or worn or improper tooling.

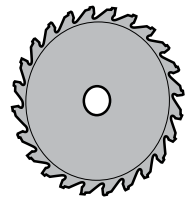

DRILLING

- AZEK Trim and Moulding products can be drilled using the same tools used to drill lumber.
- Drilling AZEK Trim and Moulding products is similar to drilling a hardwood. Care should be taken to avoid frictional heat build-up.
- Periodic removal of AZEK shavings from the drill hole may be necessary.



ROUTING

- AZEK Trim and Moulding products can be routed using standard router bits and the same tools used to rout lumber.
- Carbide tipped router bits are recommended.
- Routing AZEK Trim and Moulding products provides a crisp, clean edge.

FASTENING

- For best results, use fasteners designed for wood trim and wood siding. These fasteners have a thinner shank, blunt point, and full round head.
- A #8 trim screw may be used and works well with AZEK Trim and Moulding products.
- To take advantage of the performance of AZEK Trim and Moulding products, use a highly durable fastener such as stainless steel or hot dipped galvanized.
- Staples, small brads, and wire nails must not be used.
- The fasteners should be long enough to penetrate the solid wood substrate a minimum of 1 1/2".
- Standard nail guns work well with AZEK Trim and Moulding products. If using pneumatic tools, the air pressure should be regulated so fasteners slightly penetrate the surface.
- Like wood, use 2 fasteners per every framing member for trimboard applications. Trimboards 12" or wider, as well as sheets, will require additional fasteners, not to exceed 8" on center. See illustration below.
- Fasteners must be installed within 2" of the end of each board. See illustration below.
- There must be 2 fasteners on each side of a board joint (scarf, miter, etc.).
- All fasteners must hit a solid framing member.
- AZEK Trim and Moulding products should be fastened into a flat, solid substrate. Fastening AZEK material into hollow or uneven areas must be avoided.
- Pre-drilling is typically not required unless a large fastener is used or product is installed in low temperatures.
- 3/8" and 1/2" AZEK Sheet product is not intended to be ripped into trim pieces. These profiles must be glued to a substrate and mechanically fastened.
- AZEK BEADBOARD AND COLUMN WRAP

FASTENING CONSIDERATIONS

(Use one of the following):

- #7 trim screw
- 16 gauge T-nail
- 15 gauge round head (for 1/2" Beadboard only)
- Fasteners should be a minimum of 1 1/2" in length

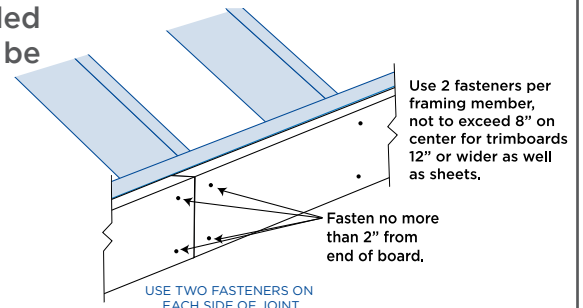

EXPANSION & CONTRACTION

- AZEK Trim and Moulding products expand and contract with changes in temperature.
- Properly fastening AZEK Trim and Moulding material along its entire length will minimize expansion and contraction.
- When properly fastened, allow 1/8" per 18 feet of AZEK Trim and Moulding products for expansion and contraction. Joints between pieces of AZEK Trim and Moulding material should be glued to eliminate joint separation. See "Gluing".
- When gaps are glued on a long run of AZEK Trim and Moulding material, allow expansion and contraction space at ends of the run.
- AZEK Trim and Moulding should be glued to a substrate and mechanically fastened to help minimize expansion and contraction.
- **WARNING:** Dark colors may increase movement and expansion and contraction of PVC Trim and Moulding.

PAINTING

- AZEK Trim and Moulding does not require paint for protection, but accepts and holds paint very well.
- If you choose to paint, AZEK recommends using a 100% acrylic latex paint with colors having a Light Reflective Value (LRV) of 55 or higher. Refer to your paint manufacturer representative or pre-finisher for color options and compatibility with AZEK Trim and Mouldings.
- AZEK Trim and Moulding surfaces must be clean, dry, and void of any foreign material such as dirt, oil, grease or other contaminants that may come from normal handling, storage and/or installation prior to painting.
- Moisture cycling is a main reason for paint failure on wood. Since AZEK Trim and Moulding material absorbs almost no moisture, paints last longer on AZEK Trim and Moulding products than it does on wood.
- Since AZEK Trim and Moulding products have almost no moisture absorption, paints may take longer to cure than on wood. Generally paints used on AZEK Trim and Moulding products will be dry to the touch quickly, but may take up to 30 days to fully cure depending on the humidity and temperature.
- **DISCLAIMER:** AZEK's Trim and Moulding Warranty does not cover the performance of painted finishes or coating applied to the Product by the original purchaser or any third party.



100% Acrylic Latex with LRV 55 or higher.

GLUING

- For best results, glue all AZEK-to-AZEK joints such as AZEK Column Wrap, window surrounds, long fascia runs, etc., with AZEK Adhesive to prevent joint separation.
- The glue joint should be fastened on each side of the joint to allow adequate bonding time.
- AZEK Adhesive has a working time of 10 minutes and will be fully cured in 24 hours.
- If standard pvc cements are used, these products typically cure quickly which will result in limited working time and may reduce adhesive strength.
- For best results, surfaces to be glued should be smooth, clean and in complete contact with each other.
- For best results, always use a scarf joint with two fasteners on each side instead of butt joints.
- To bond AZEK Trim and Mouldings to other substrates, various adhesive may be used. Consult adhesive manufacturer to determine suitability.

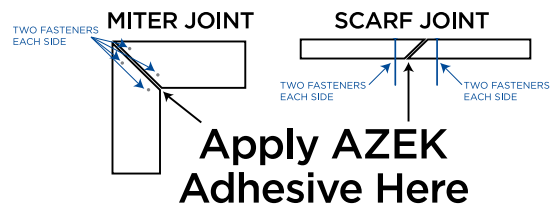

SPANNING

- AZEK Trim and Moulding products must not be used in load bearing applications, but may be used in spanned applications such as fascias, soffits and ceilings. For optimal performance, AZEK Trim and Mouldings should be installed over a solid backing.
- **FOR SOFFIT INSTALLATIONS:**
 - For spans greater than 16" OC, see below.
 - When using AZEK Beadboard, see considerations below.
- **FOR CEILING INSTALLATIONS:**
 - For spans greater than 16" OC, see below.
 - If temperature at time of installation is 40°F or below, spans need to be decreased to 12".
 - When using AZEK Beadboard, see consideration below.
- **AZEK BEADBOARD SPANNING CONSIDERATION:**
 - For both 1/2" and 5/8" AZEK Beadboard, run boards perpendicular to structure when possible to create the shortest possible run of material.
 - When using 1/2" AZEK Beadboard, use 12" OC framing as well as a high quality construction grade polyurethane adhesive on joists.
 - For spans greater than 12" OC, use 5/8" AZEK Beadboard or use a minimum 1/2" backer such as plywood or OSB with construction grade adhesive and mechanical fastening a minimum of every 8". Fasteners should hit joist or framing when possible.
 - When using 5/8" AZEK Beadboard, use 16" OC framing as well as a high quality construction grade polyurethane adhesive on joists. For spans greater than 16" OC, see below.
- For spans greater than 16" OC, use a minimum 1/2" backer such as plywood or OSB with construction grade adhesive and mechanical fastening a minimum of every 16". Fasteners should hit joist or framing when possible.
- Never span AZEK products more than 16" without utilizing instructions above. Proper fastening will help reduce the possibility of excessive movement from expansion and contraction.
- With all Beadboard or Trim ceiling and soffit installations, follow good building practices and ensure adequate ventilation is provided.

WATER TABLE

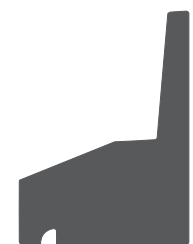
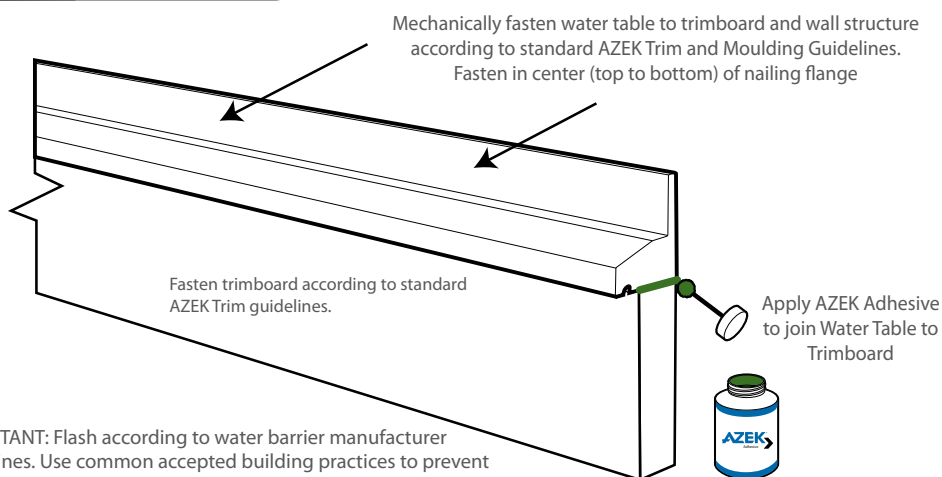

SIZE

- 2 3/4" x 2" in 18' lengths
- 1 1/2" tapered starter strip/nailing flange height
- 3/8" thick starter strip/nailing flange (at its thickest point)

IMPORTANT: Flash according to water barrier manufacturer guidelines. Use common accepted building practices to prevent water infiltration.

GARAGE DOOR THERMOSTOP

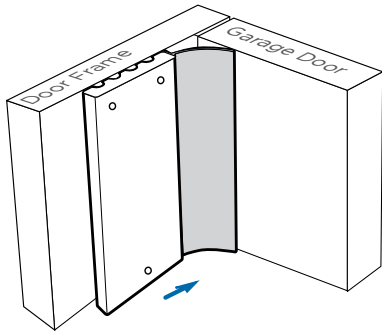

Firmly push Thermostop against Garage Door and fasten. Rubber seal should be in contact with Garage Door, but not overly tight. Place 2 fasteners within 1/2" of all ends and splices. All other fasteners should be 8" on center entire length of board.

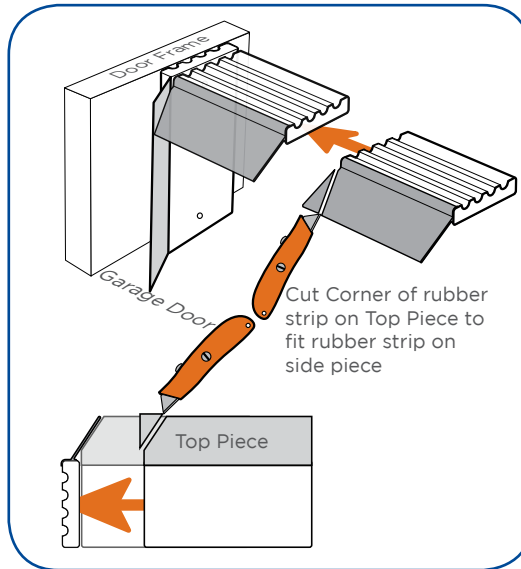

All AZEK to AZEK joints should be glued with AZEK Adhesive

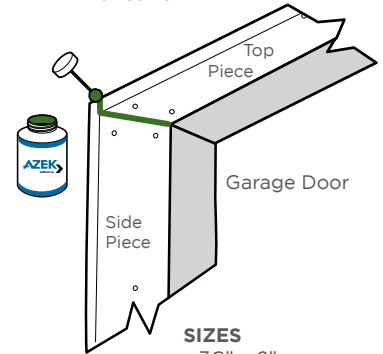

SIZES
 • 3/8" x 2"
 • 7', 9', and 16' lengths



RABBETED CORNERBOARD

Leave gap to accommodate for siding according to manufacturer recommendations.

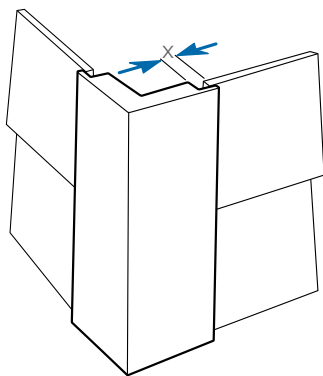

Fasten both sides according to standard AZEK Trim Guidelines. 4" Cornerboards may be installed using 2 fasteners at ends and splices and 1 fastener 12" OC through length of board.

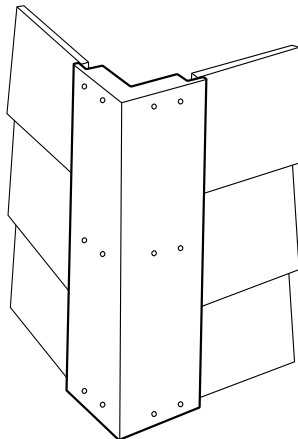

SIZES
 • 5/4 thick
 • Traditional in 4", 6" and 8" widths
 • Frontier in 4" and 6" widths
 • 10' and 20' lengths

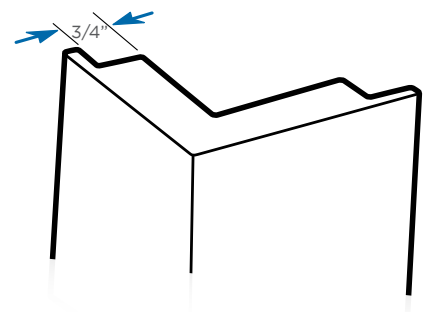

UNIVERSAL SKIRT BOARD

This is a two part product. Choose trim finish by facing either Traditional or Frontier out. Insert Universal Skirt Board interface via press fit. Once inserted, USB interface cannot be removed.

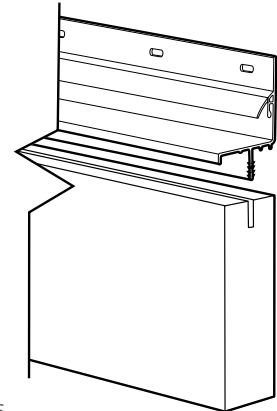
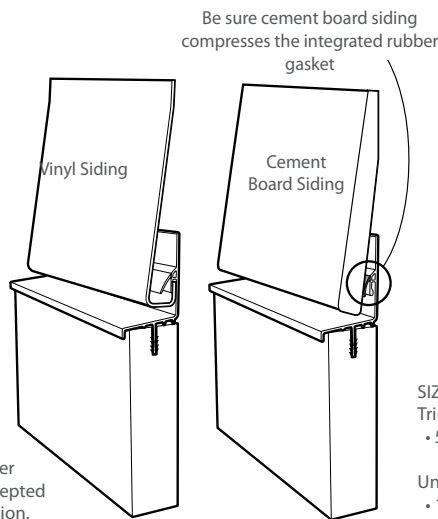
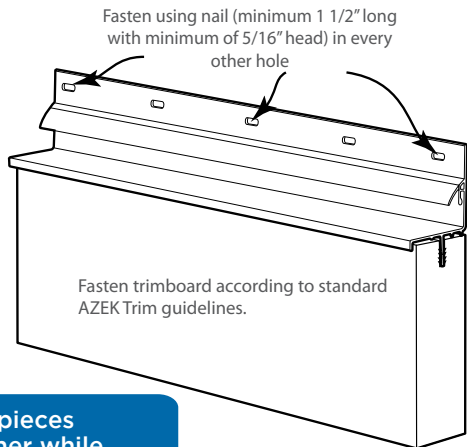

- SIZES**
- Trimboard
 - 5/4 x 6, 5/4 x 8 and 5/4 x 10 in 18' lengths
 - Universal Skirt Board Interface
 - 1 1/2" nailing flange
 - 1/4" drip edge overhang

Keep pieces together while measuring and cutting for a more accurate fit

IMPORTANT: Flash according to water barrier manufacturer guidelines. Use common accepted building practices to prevent water infiltration.

INTEGRATED DRIP EDGE

This is a two part product. Choose trim finish by facing either Traditional or Frontier out. Insert Integrated Drip Edge interface via press fit. Once inserted, IDE interface cannot be removed.

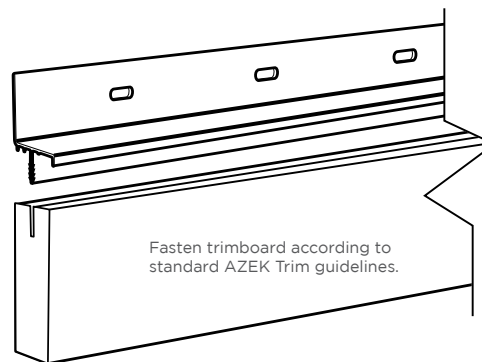
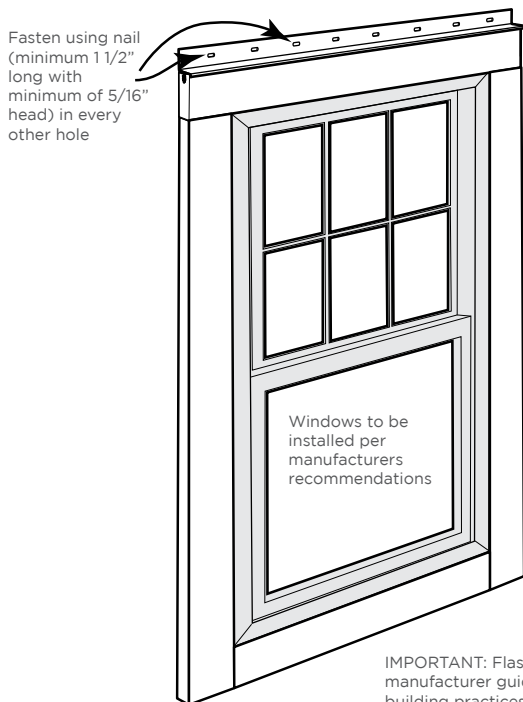

- SIZES**
- Trimboard
 - 5/4 x 4 and 5/4 x 6 in 18' lengths
 - Integrated Drip Edge Interface
 - 1 1/4" nailing flange
 - 1/8" drip edge overhang

Keep pieces together while measuring and cutting for a more accurate fit

IMPORTANT: Flash according to water barrier manufacturer guidelines. Use common accepted building practices to prevent water infiltration.

1

For easier installation; first and last piece installed should be the shortest sections

Keep pieces together while measuring and cutting for a more accurate fit

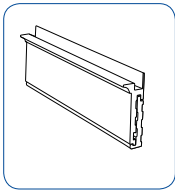

RIGHT

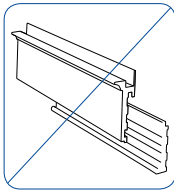

WRONG

IMPORTANT: Flash according to water barrier manufacturer guidelines. Use common accepted building practices to prevent water infiltration.

Measure and cut trim boards for mitered corners

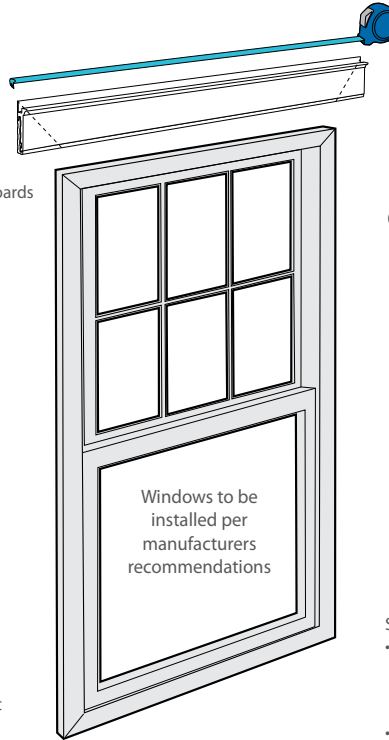

Windows to be installed per manufacturers recommendations

This is a two part product.

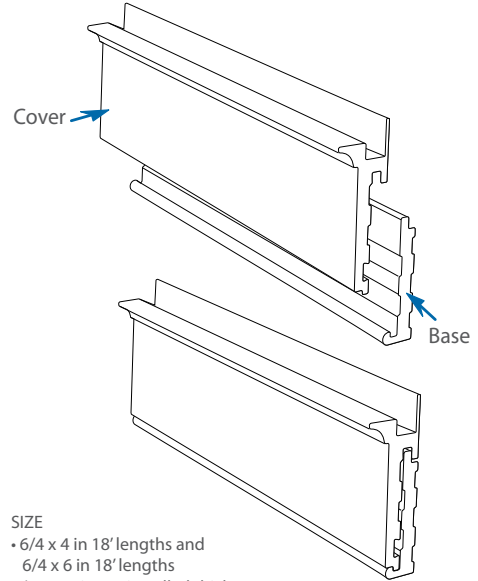

- SIZE
- 6/4 x 4 in 18' lengths and 6/4 x 6 in 18' lengths (approximate installed thickness and width)
 - Traditional finish only

2

Fasten Base according to standard AZEK Trim Guidelines

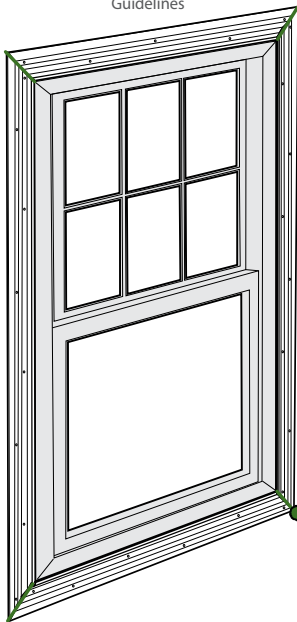

Glue all AZEK to AZEK joints

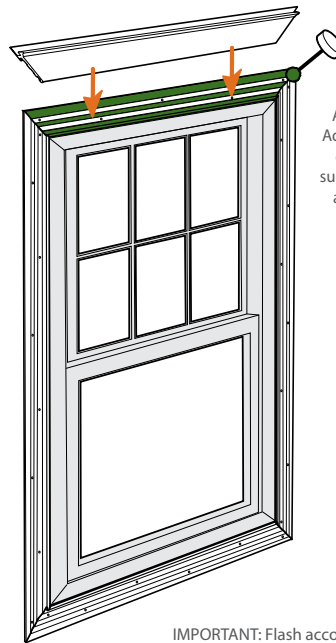

Apply AZEK Adhesive to all contacting surfaces before assembling cover

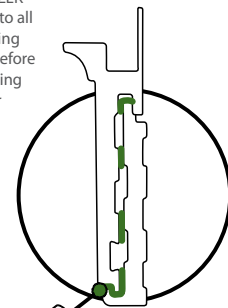

IMPORTANT: Flash according to water barrier manufacturer guidelines. Use common accepted building practices to prevent water infiltration.

3

Mechanically fasten through nailing flange using recommended AZEK Trim fastener

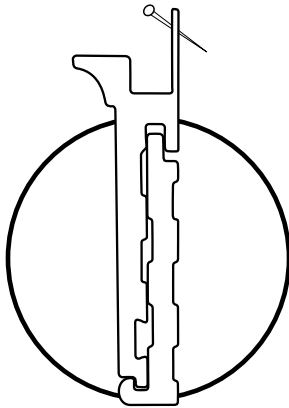

Apply AZEK Adhesive and insert corner reinforcements

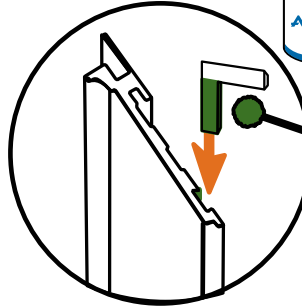

As illustrated, apply AZEK Adhesive to base trim piece before installing Finish Grade Trim cover.

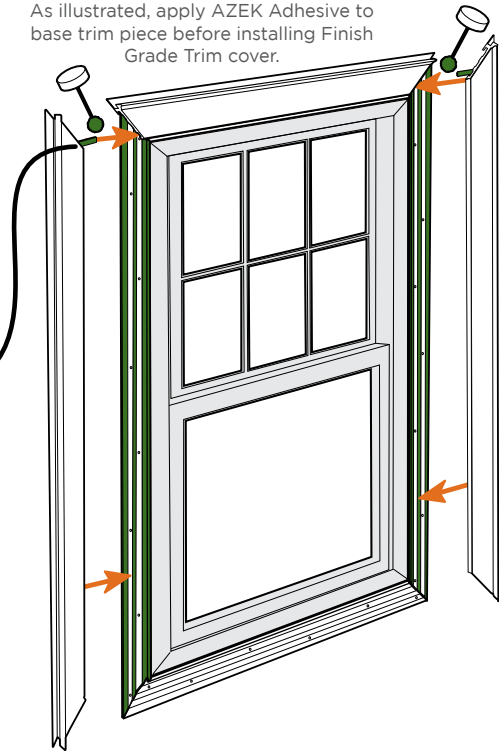

4

Tack covers at top to allow play at bottom for installing last piece

Glue all AZEK to AZEK joints with AZEK Adhesive

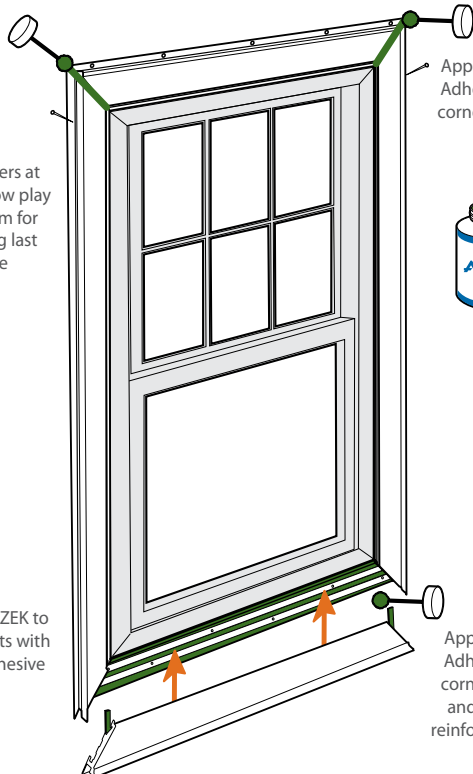

Apply AZEK Adhesive to corner joints



Apply AZEK Adhesive to corner joints and corner reinforcements

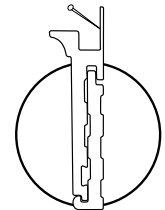
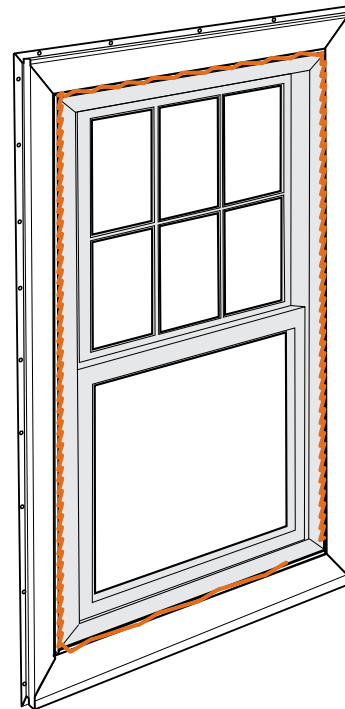

Complete the attachment of Finish Grade covers by mechanically fastening through nailing flange with recommended AZEK Trim fastener.

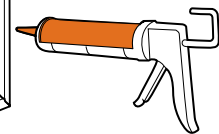

Caulk joint between window and trim to ensure proper seal

WARNING! Please read all instructions completely before starting any part of the installation.

- AZEK Column Wraps are not structural and are not intended for load bearing applications.
- Manufactured edges of the column wrap are sharp and should be handled with care.
- AZEK Column Wrap should be installed in accordance with the local building codes and the installation guidelines included below. AZEK Building Products Inc. accepts no liability or responsibility for the improper installation of this product. Failure to install AZEK Column Wrap in accordance with applicable building codes and this Installation Guide may lead to personal injury, affect product performance and void the product warranty.
- AZEK Column Wrap may not be suitable for every application. It is the sole responsibility of the installer to be sure that AZEK Column Wraps are fit for the intended use. Since all installations are unique, it is also the installer's responsibility to determine specific requirements in regards to each application.
- AZEK Building Products recommends that all applications be reviewed by a licensed architect, engineer, or local building official before installation. If you have any questions or need further assistance, please call AZEK Customer Service at 877-ASK-AZEK (877-275-2935) or visit our website at www.AZEK.com.

Parts

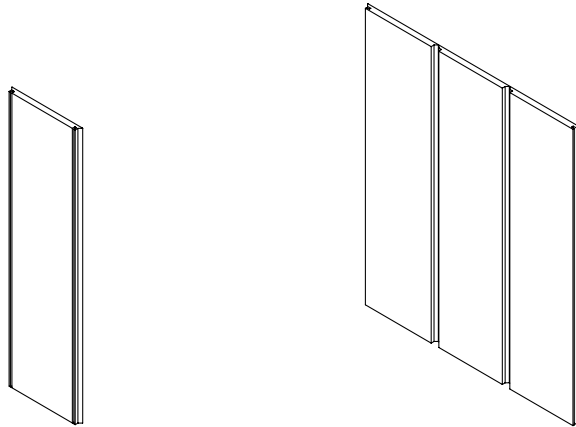

1

MEASURE POST HEIGHT AND CUT COLUMN WRAP TO DESIRED LENGTH

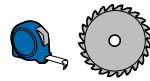

Make sure three connected panels and locking panel are cut evenly.

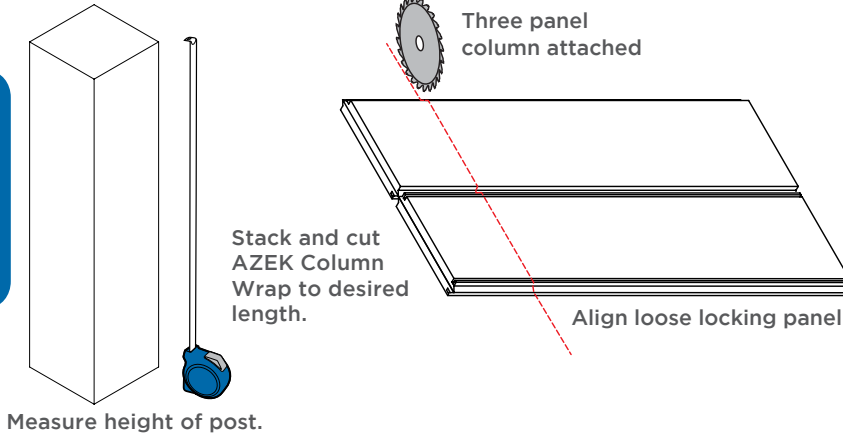

Measure height of post.

2

INSTALL SHIMS TO POST IF NEEDED

(Optional)

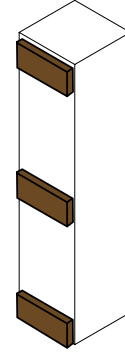

If necessary, install thin shims to the top, middle and bottom of the structural post so that the Column Wrap fits tightly around the structural post. Shim all four (4) sides evenly to maintain equal spacing around the post. Be sure the shimmed outside dimensions are no wider than the inside dimensions of the AZEK Column Wrap.

3

ADD ADHESIVE TO THREE PANEL COLUMN WRAP

Apply adhesive in the orange areas.

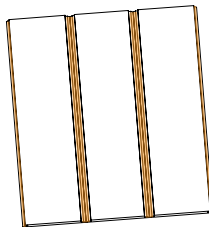

Apply a small bead of Cellular PVC adhesive to the bead/groove corner joints and grooved female ends of the three panel column wrap.

Acceptable Adhesives:

- AZEK Adhesive
- Devcon Trimbond
- Extreme Adhesives (Fast Cure)
- OSI TeQBond

* Warning: Do not apply excessive adhesive to corner joints.

4

PLACE THREE PANEL COLUMN WRAP AROUND POST

Fold and lock panels together horizontally and place the column wrap around the post as shown.

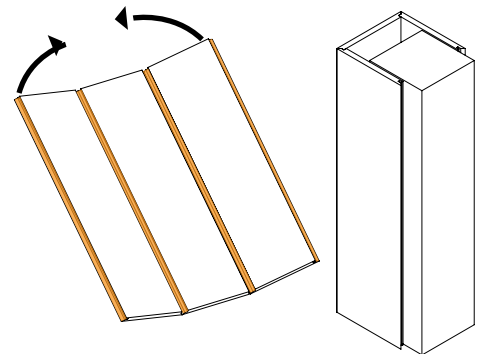

5

SNAP THE LOCKING PANEL TO THE THREE PANEL COLUMN WRAP

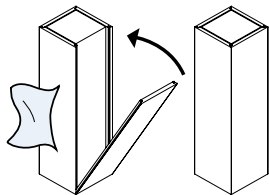

Start at the bottom of the three panel AZEK Column Wrap.

Fit the tongue of the locking panel into the grooved ends of the folded three connected panels. Carefully apply pressure with a clean rag so it snaps into place. Secure/clamp Column Wrap to allow adhesive to cure.

6

WIPE EXCESS ADHESIVE OFF WITH CLEAN RAG

Remove tape from joint prior to full cure and wipe excess adhesive off edges.

Note: When using AZEK Column Wrap around a post in a railing application, solid blocking must be attached between the post and the AZEK Column Wrap. Refer to your local building code for details.

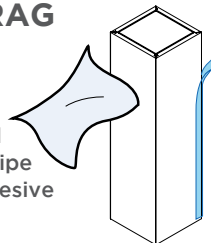

7

FASTEN COLUMN WRAP TO POST / EASE EDGES

(Optional)

Column Wrap may be fastened to the post using stainless steel nails or exterior grade screws. Nail or screw holes can be easily filled using a sealant or comparable products formulated specifically for use with cellular PVC.

If possible position fasteners where they can be covered by mouldings.

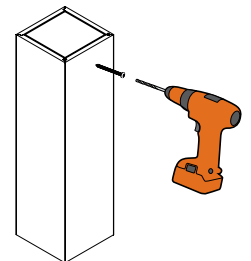

Recommendation: Use hand held Slickplane[®] tool to ease edges after tape is removed.

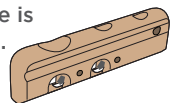

Slickplane[®] Tool



AZEK Building Products, Inc.
888 North Keyser Avenue • Scranton, PA 18504
www.AZEK.com • (877) ASK-AZEK (877) 275-2935