INSTALLATION INSTRUCTIONS

COMMERCIAL DRYER

Gas (120-Volt, 60-Hz) or Electric (120/240-Volt, 60-Hz)

Table of Contents 2

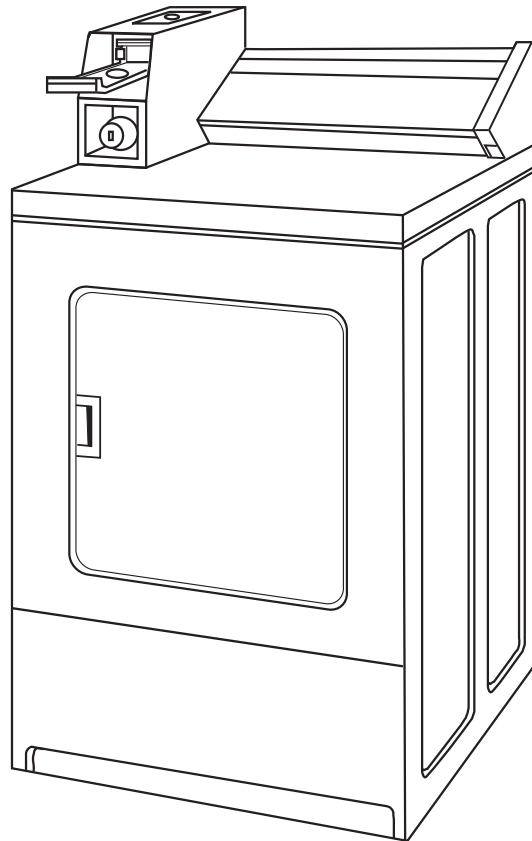

TABLE OF CONTENTS

DRYER SAFETY	2	INSTALLATION INSTRUCTIONS – GAS DRYER	10
INSTALLATION REQUIREMENTS	4	Connect Vent	10
Tools and Parts	4	Complete Installation	10
Location Requirements	5	INSTALLATION INSTRUCTIONS – ELECTRIC DRYER	11
Electrical Requirements	6	Install Coin Slide and Coin Box	11
Gas Supply Requirements	7	Make Electrical Connection	11
Venting Requirements	8	Connect Vent	15
INSTALLATION INSTRUCTIONS – GAS DRYER	10	Complete Installation	15
Install Coin Slide and Coin Box	10	CHANGING TO A 30- OR 60-MINUTE TIMING CAM	16
Make Gas Connection	10		

DRYER SAFETY

Your safety and the safety of others are very important.

We have provided many important safety messages in this manual and on your appliance. Always read and obey all safety messages.



This is the safety alert symbol.

This symbol alerts you to potential hazards that can kill or hurt you and others.

All safety messages will follow the safety alert symbol and either the word “DANGER” or “WARNING.”

These words mean:

⚠ DANGER

You can be killed or seriously injured if you don't immediately follow instructions.

⚠ WARNING

You can be killed or seriously injured if you don't follow instructions.

All safety messages will tell you what the potential hazard is, tell you how to reduce the chance of injury, and tell you what can happen if the instructions are not followed.



WARNING - “Risk of Fire”

- Clothes dryer installation must be performed by a qualified installer.
- Install the clothes dryer according to the manufacturer's instructions and local codes.
- Do not install a clothes dryer with flexible plastic venting materials. If flexible metal (foil type) duct is installed, it must be of a specific type identified by the appliance manufacturer as suitable for use with clothes dryers. Flexible venting materials are known to collapse, be easily crushed, and trap lint. These conditions will obstruct clothes dryer airflow and increase the risk of fire.
- To reduce the risk of severe injury or death, follow all installation instructions.
- Save these instructions.

- It is recommended that the owner post, in a prominent location, instructions for the customer's use in the event the customer smells gas. This information should be obtained from your gas supplier.
- Post the following warning in a prominent location.

FOR YOUR SAFETY

Do not store or use gasoline or other flammable vapors and liquids in the vicinity of this or any other appliance.

IMPORTANT SAFETY INSTRUCTIONS

WARNING: To reduce the risk of fire, electric shock, or injury to persons when using the dryer, follow basic precautions, including the following:

- Read all instructions before using the dryer.
- Do not place items exposed to cooking oils in your dryer. Items contaminated with cooking oils may contribute to a chemical reaction that could cause a load to catch fire.
- Do not dry articles that have been previously cleaned in, washed in, soaked in, or spotted with gasoline, dry-cleaning solvents, or other flammable or explosive substances as they give off vapors that could ignite or explode.
- Do not allow children to play on or in the dryer. Close supervision of children is necessary when the dryer is used near children.
- Before the dryer is removed from service or discarded, remove the door to the drying compartment.
- Do not reach into the dryer if the drum is moving.
- Do not install or store the dryer where it will be exposed to the weather.
- Do not tamper with controls.
- Do not repair or replace any part of the dryer or attempt any servicing unless specifically recommended in this Use and Care Guide or in published user-repair instructions that you understand and have the skills to carry out.
- Do not use fabric softeners or products to eliminate static unless recommended by the manufacturer of the fabric softener or product.
- Do not use heat to dry articles containing foam rubber or similarly textured rubber-like materials.
- Clean lint screen before or after each load.
- Keep area around the exhaust opening and adjacent surrounding areas free from the accumulation of lint, dust, and dirt.
- The interior of the dryer and exhaust vent should be cleaned periodically by qualified service personnel.
- See installation instructions for grounding requirements.

SAVE THESE INSTRUCTIONS

IMPORTANT: The gas installation must conform with local codes, or in the absence of local codes, with the National Fuel Gas Code, ANSI Z223.1/NFPA 54 or the Canadian Natural Gas and Propane Installation Code, CSA B149.1.

The dryer must be electrically grounded in accordance with local codes, or in the absence of local codes, with the National Electrical Code, ANSI/NFPA 70 or Canadian Electrical Code, CSA C22.1.

WARNING: For your safety, the information in this manual must be followed to minimize the risk of fire or explosion, or to prevent property damage, personal injury, or death.

- Do not store or use gasoline or other flammable vapors and liquids in the vicinity of this or any other appliance.
- **WHAT TO DO IF YOU SMELL GAS:**
 - Do not try to light any appliance.
 - Do not touch any electrical switch; do not use any phone in your building.
 - Clear the room, building, or area of all occupants.
 - Immediately call your gas supplier from a neighbor's phone. Follow the gas supplier's instructions.
 - If you cannot reach your gas supplier, call the fire department.
- Installation and service must be performed by a qualified installer, service agency, or the gas supplier.

WARNING: Gas leaks cannot always be detected by smell.

Gas suppliers recommend that you use a gas detector approved by UL or CSA.

For more information, contact your gas supplier.

If a gas leak is detected, follow the "What to do if you smell gas" instructions.

In the State of Massachusetts, the following installation instructions apply:

- Installations and repairs must be performed by a qualified or licensed contractor, plumber, or gasfitter qualified or licensed by the State of Massachusetts.
- If using a ball valve, it shall be a T-handle type.
- A flexible gas connector, when used, must not exceed 3 feet.

INSTALLATION REQUIREMENTS

Tools and Parts

Gather the required tools and parts before starting installation. Read and follow the instructions provided with any tools listed here.

Tools needed

- 8" or 10" pipe wrench
- 8" or 10" adjustable wrench
- Flat-blade screwdriver
- Phillips screwdriver
- Adjustable wrench that opens to 1" (25 mm) or hex-head socket wrench
- Level
- 5/16" socket wrench
- Utility knife
- Vent clamps
- Pipe-joint compound resistant to LP gas
- Caulk gun and caulk (for installing new exhaust vent)
- Pliers
- Putty knife

Parts supplied

Remove parts bag from dryer drum. Check that all parts were included.

- Wedge cone
- Dryer foot (4)
- 5/16"-18 x 2 1/2" bolt
- 3 pin timing cam
- 6 pin timing cam

Location Requirements

⚠ WARNING



Explosion Hazard

Keep flammable materials and vapors, such as gasoline, away from dryer.

Do not install in a garage.

Failure to do so can result in death, explosion, or fire.

If installing a gas dryer:

IMPORTANT: Observe all governing codes and ordinances.

- Check code requirements: Some codes limit or do not permit installation of clothes dryers in garages, closets, or sleeping quarters. Contact your local building inspector.
- Make sure that lower edges of the cabinet, plus the back and bottom sides of the dryer, are free of obstructions to permit adequate clearance of air openings for combustion air. See "Recessed Area and Closet Installation Instructions" below for minimum spacing requirements.

NOTE: The dryer must not be installed in an area where it will be exposed to water and/or weather.

Recessed Area and Closet Installation Instructions

This dryer may be installed in a recessed area or closet. For recessed area and closet installations, minimum clearances can be found on the serial tag on the dryer.

The installation spacing is in inches and is the minimum allowable. Additional spacing should be considered for ease of installation, servicing, and compliance with local codes and ordinances.

If closet door is installed, the minimum unobstructed air opening in the top and bottom is required. Louvered doors with equivalent air openings are acceptable.

The dryer must be exhausted outdoors.

No other fuel-burning appliance may be installed in the same closet as the dryer.

Minimum Installation Clearances

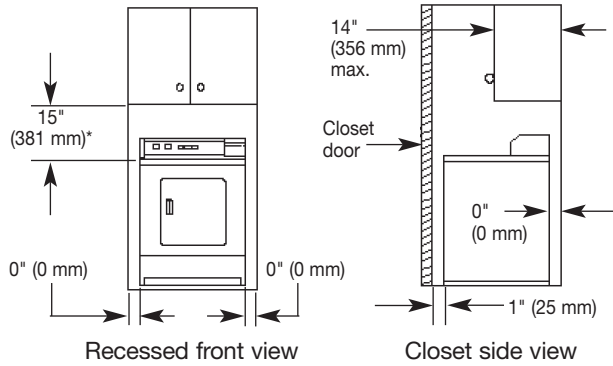

Additional clearances for wall, door and floor moldings may be required or if external exhaust elbow is used.

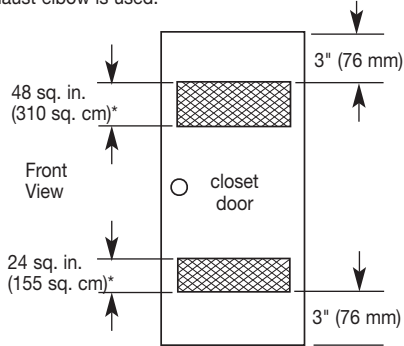

*Opening is the minimum for a closet door. Louvered doors with equivalent air openings are acceptable.

Product Dimensions 27" (686 mm) dryer

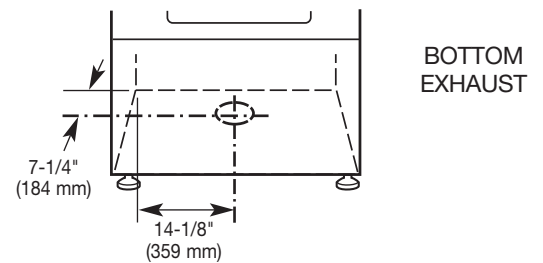
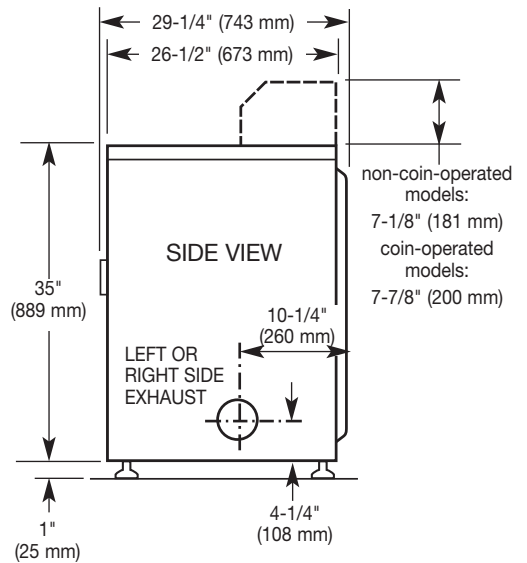
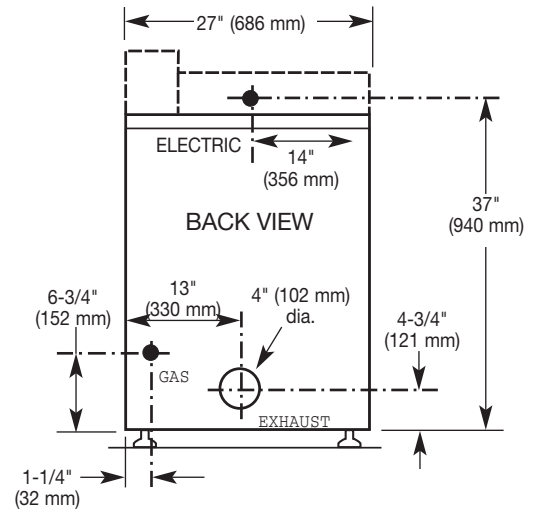

Product Dimensions 29" (737 mm) dryer

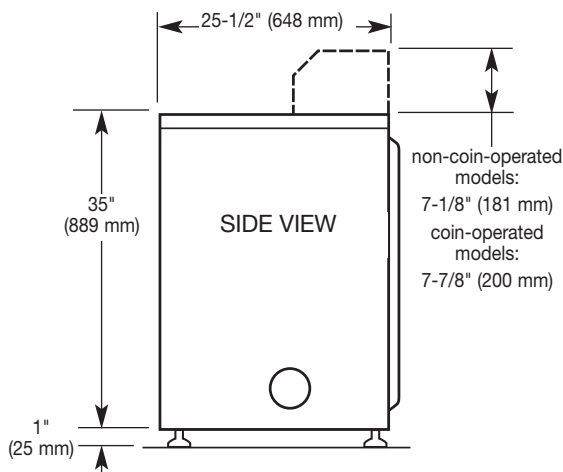
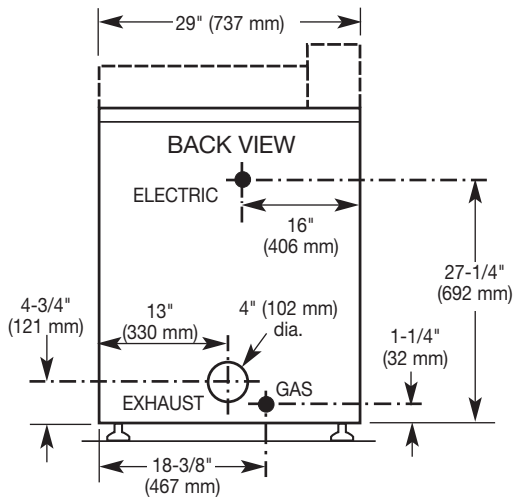

Electrical Requirements - Gas Dryer

⚠ WARNING



Electrical Shock Hazard

Plug into a grounded 3 prong outlet.

Do not remove ground prong.

Do not use an adapter.

Do not use an extension cord.

Failure to follow these instructions can result in death, fire, or electrical shock.

IMPORTANT: The dryer must be electrically grounded in accordance with local codes and ordinances or, in the absence of local codes, with the National Electrical Code, ANSI/NFPA 70, latest edition.

If codes permit and a separate ground wire is used, it is recommended that a qualified electrical installer determine that the ground path is adequate.

A copy of the above code standards can be obtained from:

National Fire Protection Association
One Batterymarch Park, Quincy, MA 02269

- A 120-volt, 60-Hz, AC-only, 15- or 20-amp, fused electrical circuit is required. A time-delay fuse or circuit breaker is also recommended. It is recommended that a separate circuit serving only this dryer be provided.

Recommended Ground Method

The dryer, when installed, must be electrically grounded in accordance with local codes or, in the absence of local codes, with the National Electrical Code, ANSI/NFPA 70, latest edition.

GROUNDING INSTRUCTIONS

- For a grounded, cord-connected dryer:
This dryer must be grounded. In the event of a malfunction or breakdown, grounding will reduce the risk of electric shock by providing a path of least resistance for electric current. This dryer is equipped with a cord having an equipment-grounding conductor and a grounding plug. The plug must be plugged into an appropriate outlet that is properly installed and grounded in accordance with all local codes and ordinances.

WARNING: Improper connection of the equipment-grounding conductor can result in a risk of electric shock. Check with a qualified electrician or service representative or personnel if you are in doubt as to whether the dryer is properly grounded. Do not modify the plug provided with the dryer: if it will not fit the outlet, have a proper outlet installed by a qualified electrician.

SAVE THESE INSTRUCTIONS

Electrical Requirements - Electric Dryer

IMPORTANT: The dryer must be electrically grounded in accordance with local codes and ordinances or, in the absence of local codes, with the National Electrical Code, ANSI/NFPA 70, latest edition.

The National Electrical Code requires a 4-wire supply connection for homes built after 1996, dryer circuits involved in remodeling after 1996, and all mobile home installations.

If codes permit and a separate ground wire is used, it is recommended that a qualified electrical installer determine that the ground path is adequate.

A copy of the above code standards can be obtained from:

National Fire Protection Association
One Batterymarch Park, Quincy, MA 02269

- A four-wire or three-wire, single-phase, 120/240-volt, 60-Hz, AC-only electrical supply (or four-wire or three-wire, 120/208-volt, if specified on the model/serial rating plate) is required on a separate, 30-amp circuit, fused on both sides of the line. A time-delay fuse or circuit breaker is recommended.

Recommended Ground Method

It is your responsibility to contact a qualified electrical installer to ensure that the electrical installation is adequate and in conformance with the National Electrical Code, ANSI/NFPA 70, latest edition, and all local codes and ordinances.

GROUNDING INSTRUCTIONS

- For a grounded, cord-connected dryer:
This dryer must be grounded. In the event of a malfunction or breakdown, grounding will reduce the risk of electric shock by providing a path of least resistance for electric current. This dryer uses a cord having an equipment-grounding conductor and a grounding plug. The plug must be plugged into an appropriate outlet that is properly installed and grounded in accordance with all local codes and ordinances.
- For a permanently connected dryer:
This dryer must be connected to a grounded metal, permanent wiring system, or an equipment-grounding conductor must be run with the circuit conductors and connected to the equipment-grounding terminal or lead on the dryer.

WARNING: Improper connection of the equipment-grounding conductor can result in a risk of electric shock. Check with a qualified electrician or service representative or personnel if you are in doubt as to whether the dryer is properly grounded. Do not modify the plug on the power supply cord: if it will not fit the outlet, have a proper outlet installed by a qualified electrician.

SAVE THESE INSTRUCTIONS

Gas Supply Requirements

⚠ WARNING



Explosion Hazard

Use a new CSA International approved gas supply line.

Install a shut-off valve.

Securely tighten all gas connections.

If connected to LP, have a qualified person make sure gas pressure does not exceed 13" (330 mm) water column.

Examples of a qualified person include:

**licensed heating personnel,
authorized gas company personnel, and
authorized service personnel.**

Failure to do so can result in death, explosion, or fire.

IMPORTANT: Observe all governing codes and ordinances.

This installation must conform with all local codes and ordinances. In the absence of local codes, installation must conform with American National Standard, National Fuel Gas Code ANSI Z223.1/NFPA 54.

A copy of the above code standards can be obtained from:

National Fire Protection Association
One Batterymarch Park, Quincy, MA 02269

The design of this dryer has been certified by CSA International for use at altitudes up to 10,000 feet (3048 m) above sea level at the B.T.U. rating indicated on the model/serial plate. Burner input adjustments are not required when the dryer is operated up to this elevation.

When installed above 10,000 feet (3048 m), a four percent (4%) reduction of the burner B.T.U. rating shown on the model/serial plate is required for each 1,000 foot (305 m) increase in elevation. For assistance when converting to other gas types and/or installing above 10,000 feet (3048 m) elevation, contact your local service company.

Type of Gas

This dryer is equipped for use with natural gas. It is design-certified by CSA International for L.P. (propane and butane) gases with appropriate conversion. No attempt shall be made to convert the dryer from the gas specified on the serial/rating plate for use with a different gas without consulting the serving gas supplier. Conversion must be done by a qualified service technician. Gas conversion kit part numbers are listed on the gas valve burner base.

Gas Supply Line

Recommended method

- Provide a gas supply line of 1/2" rigid (IPS) pipe to the dryer location. Pipe joint compounds that resist the action of LP gas must be used. Do not use TEFLON[®] tape. With LP gas, piping or tubing size can be 1/2" minimum. Usually, LP gas suppliers determine the size and materials used in the system.

Alternate method

- The gas supply may also be connected using 3/8" approved copper or aluminum tubing. If the total length of the supply line is more than 20 feet (6.1 m), larger tubing will be required. If using natural gas, do not use copper tubing. Pipe joint compounds that resist the action of LP gas must be used.

Flexible metal appliance connector:

- It is recommended that a new flexible stainless steel gas line, design-certified by CSA International, be used for connecting the dryer to the gas supply line. (The gas pipe which extends through the lower rear of the dryer is provided with 3/8" male

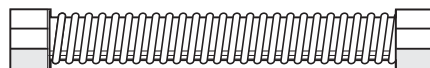

pipe thread.)

- Do not kink or damage the flexible stainless steel gas line when moving the dryer.

Rigid pipe connection:

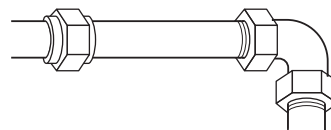

The rigid pipe connection requires a combination of pipe fittings to obtain an in-line connection to the dryer.

- Must include a shutoff valve:

The supply line must be equipped with a manual shutoff valve installed within 6 ft. (1.8 m) of dryer in accordance with National Fuel Gas Code, ANSI Z223.1. This valve should be located in the same room as the dryer. It should be in a

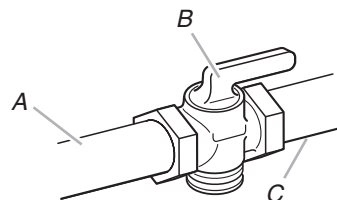

A. Gas supply line
B. Shutoff valve "open" position
C. To dryer

location that allows ease of opening and closing. Do not block access to shutoff valve. The valve is for turning on or shutting off gas to the dryer.

- Installed in a confined area:

If the dryer is installed in a confined area such as a bathroom or closet, provision must be made for enough air for combustion and ventilation. Check governing codes and

†®TEFLON is a registered trademark of E.I. Du Pont De Nemours and Company.

ordinances or refer to the "Recessed Area and Closet Installation Instructions" in the "Location Requirements" section.

Gas Supply Pressure Testing

A 1/8" NPT minimum plugged tapping, accessible for gauge testing, must be installed immediately upstream of the gas supply connection to the dryer.

The dryer must be disconnected from the gas supply piping system during any pressure testing of the system at test pressures in excess of 1/2" psig.

WARNING



Fire Hazard

Use a heavy metal vent.

Do not use a plastic vent.

Do not use a metal foil vent.

Failure to follow these instructions can result in death or fire.

Venting Requirements

WARNING: To reduce the risk of fire, this dryer MUST BE EXHAUSTED OUTDOORS.

IMPORTANT: Observe all governing codes and ordinances.

- Only rigid or flexible metal duct shall be used for exhausting.
- The dryer vent must not be connected into any gas vent, chimney, wall, ceiling, attic, crawlspace, or a concealed space of a building.
- Do not use an exhaust hood with a magnetic latch.
- Do not install flexible metal vent in enclosed walls, ceilings, or floors.
- 4" (102 mm) heavy metal vent and clamps must be used.
- Use clamps to seal all joints. Vent must not be connected or secured with screws or other fastening devices which extend into the interior of the vent and catch lint. Do not use duct tape.

Use a heavy metal vent. Do not use plastic or metal foil vent.

Rigid metal vent is recommended to prevent crushing and kinking.

Flexible metal vent must be fully extended and supported when the dryer is in its final position. Remove excess flexible metal vent to avoid sagging and kinking that may result in reduced airflow and poor performance.

The total length of flexible metal duct shall not exceed 7³/₄ ft (2.4 m).

An exhaust hood should cap the vent to prevent rodents and insects from entering the home or business.

Exhaust hood must be at least 12" (305 mm) from the ground or any object that may be in the path of the exhaust (such as flowers, rocks, or bushes).

If using an existing vent system, clean lint from the entire length of the system and make sure exhaust hood is not plugged with lint. Replace any plastic or metal foil vent with rigid metal or flexible metal vent.

Plan installation to use the fewest number of elbows and turns.

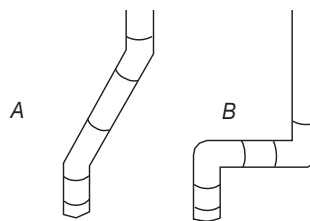

Exhaust Air Flow

A. Better

B. Good

Allow as much room as possible when using elbows or making turns. Bend vent gradually to avoid kinking.

Vent outlet is located at the center of the bottom dryer back.

The vent can be routed up, down, left, right, behind the dryer, or straight out the back of the dryer.

Vent System Length

Maximum length of vent system depends upon the type of vent used, number of elbows and type of exhaust hood. The maximum length for rigid metal venting is shown in the chart.

Maximum Vent Length

4" (102 mm) Diameter Exhaust Hoods

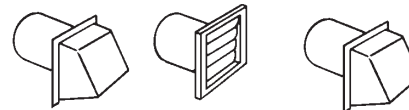

Rigid Metal Vent

No. of 90° turns	Box Hood and Louvered Style	Angled Hood Style
0	64 ft. (19.5 m)	58 ft. (17.7 m)
1	54 ft. (16.5 m)	48 ft. (14.6 m)
2	44 ft. (13.4 m)	38 ft. (11.6 m)
3	35 ft. (10.7 m)	29 ft. (8.8 m)
4	27 ft. (8.2 m)	21 ft. (6.4 m)

For vent systems not covered by the vent specification chart, see Whirlpool Service Manual, "Exhausting Whirlpool Dryers," Part No. LIT603197, available from your Whirlpool parts distributor.

If dryer is installed in a confined area, such as a bedroom, bathroom or closet, provision must be made for enough air for combustion and ventilation. (Check governing codes and ordinances.) See "Recessed Area and Closet Installation Instructions" in the "Location Requirements" section.

A four-inch outlet hood is preferred. However, a 2¹/₂" (640 mm) outlet exhaust hood may be used. A 2¹/₂" (640 mm) outlet creates greater back pressure than other hood types. For permanent installation, a stationary vent system is required.

Multiple Dryer Venting

- A main vent can be used for venting a group of dryers. Main vent should be sized to remove 200 CFM of air per dryer. Large-capacity lint screens of proper design may be used in the main vent if checked and cleaned frequently. The room where the dryers are located should have make-up air equal to or greater than the CFM of all the dryers in the room.
- Back-draft Damper Kits, Part No. 3391910, are available from your Whirlpool dealer and should be installed in each dryer's vent to prevent exhausted air from returning into the dryers and to keep the exhaust in balance within the main vent. Unobstructed air openings are required.

Each vent should enter the main vent at an angle pointing in the direction of the airflow. Vents entering from the opposite side should be staggered to reduce the exhausted air from interfering with the other vents.

The maximum angle of each vent entering the main vent should be no more than 30°.

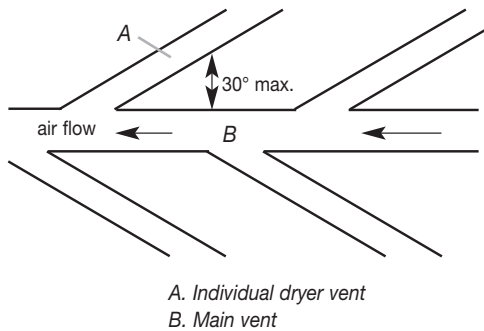

Keep air openings free of dry cleaning fluid fumes. Fumes create acids which, when drawn through the dryer heating units, can damage dryers and loads being dried.

A clean-out cover should be located on the main vent for periodic cleaning of the vent system.

If an exhaust hood cannot be used:

The outside end of the main vent should have a sweep elbow directed downward. If the main vent travels vertically through the roof, rather than through the wall, install a 180° sweep elbow on the end of the vent at least 2 feet (610 mm) above the highest part of the building. The opening wall or roof shall have a diameter 1/2" (13 mm) larger than the vent diameter. The vent should be centered in the opening.

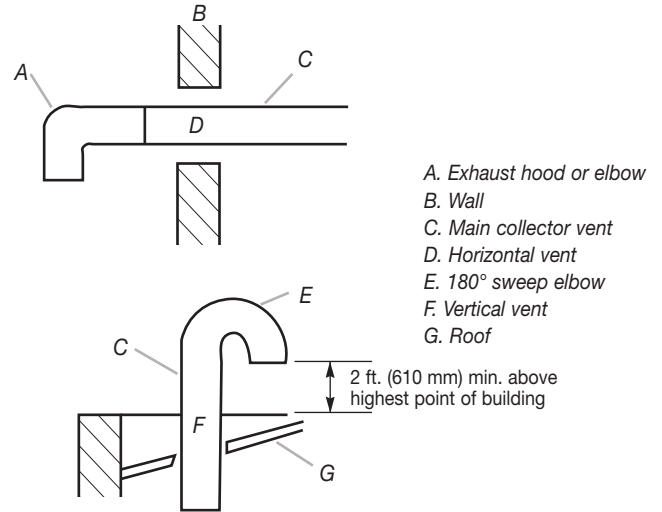

Do not install screening or cap over the end of the vent.

INSTALLATION INSTRUCTIONS – GAS DRYER

Install Coin Slide and Coin Box

The console houses the factory-installed accumulator timer with actuating arm and button.

The timer installed is set to provide 45 minutes (4 pins) of drying time when activated by the coin slide. Timer cams for 30-minute (6 pins) and 60-minute (3 pins) drying times are included in the parts bag.

The coin-slide mechanism, control panel lock and key, and coin-box lock and key are not included and are available from usual industry sources.

⚠ WARNING

Excessive Weight Hazard

**Use two or more people to move and install dryer.
Failure to do so can result in back or other injury.**

NOTE: Slide dryer onto cardboard or hardboard before moving to avoid damaging floor covering.

1. Using two or more people, move dryer to desired installation location.
2. Take tape off front corners of dryer. Open dryer and remove the literature and parts packages. Wipe the interior of the drum thoroughly with a damp cloth.
3. Take two of the cardboard corners from the carton and place them on the floor in back of the dryer. Firmly grasp the body of the dryer and gently lay it on its back on the cardboard corners.
4. With one of the legs in hand, check the ridges for a diamond marking. That's how far the leg is supposed to go into the hole.
5. Start to screw the leveling legs into the holes by hand. (Use a small amount of liquid detergent to lubricate the screw threads so it is easier to turn the legs.) Use a 1-inch wrench or socket wrench to finish turning the legs until you reach the diamond mark.
Now stand the dryer up.
6. Remove the service door of the meter case by lifting it up at the back. Install the money-accepting device. (Refer to manufacturer's instructions for proper installation.)

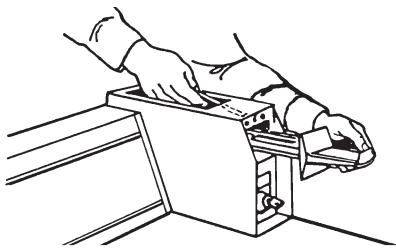

For dryers using coin slides, use adapter kit supplied with dryer.

7. Replace the meter case service door. Put the coin vault with lock and key in the meter case opening.
8. Remove cardboard or hardboard from under dryer.

Make Gas Connection

1. Remove red cap from gas pipe.
2. Connect gas supply to dryer. Use pipe-joint compound resistant to the action of L.P. gas for gas connections. If flexible metal tubing is used, be certain there are no kinks.
3. Open the shutoff valve in the gas supply line.
4. Test all connections by brushing on an approved noncorrosive leak-detection solution. Bubbles will show a leak. Correct any leaks found.

Connect Vent

1. Using a 4" (102 mm) clamp, connect vent to exhaust outlet in dryer. If connecting to existing vent, make sure the vent is clean. The dryer vent must fit over the dryer exhaust outlet and inside the exhaust hood. Make sure the vent is secured to exhaust hood with a 4" (102 mm) clamp.
2. Move dryer into final position. Do not crush or kink vent. Make sure dryer is level.
3. Check to be sure there are no kinks in the flexible gas line.

Complete Installation

1. With dryer in final position place level on top of the dryer, first side to side; then front to back. If the dryer is not level, adjust the legs of the dryer up or down until the dryer is level.

⚠ WARNING



Electrical Shock Hazard

Plug into a grounded 3 prong outlet.

Do not remove ground prong.

Do not use an adapter.

Do not use an extension cord.

Failure to follow these instructions can result in death, fire, or electrical shock.

2. Plug into a grounded 3 prong outlet.
3. Check dryer operation (some accumulated time may be on the timer due to factory testing).

Insert coins in slide and press slide in slowly. (Operating time will accumulate per number of coins and type of timing cam used.) Push START/RESTART button. Using a full heat cycle (not the air cycle), let the dryer run for at least five minutes. Dryer will stop when time is used up.

NOTE: Dryer door must be closed for dryer to operate. When door is open, dryer stops, but timer continues to run. To restart dryer, close door and push START/RESTART button.

4. If the burner does not ignite and you can feel no heat inside the dryer, shut off dryer for five minutes. Check that all supply valve controls are in "ON" position and that the electrical cord is plugged in. Repeat five-minute test.
5. If drying time is too long, make sure lint screen is clean.

INSTALLATION INSTRUCTIONS - ELECTRIC DRYER

Install Coin Slide and Coin Box

The console houses the factory-installed accumulator timer with actuating arm and button.

The timer installed is set to provide 45 minutes (4 pins) of drying time when activated by the coin slide. Timer cams for 30-minute (6 pins) and 60-minute (3 pins) drying times are included in the parts bag.

The coin slide mechanism, control panel lock and key, and coin box lock and key are not included and are available from usual industry sources.

⚠️ WARNING

Excessive Weight Hazard

**Use two or more people to move and install dryer.
Failure to do so can result in back or other injury.**

NOTE: Slide dryer onto cardboard or hardboard before moving to avoid damaging floor covering.

1. Using two or more people, move dryer to desired installation location.
2. Take tape off front corners of dryer. Open dryer and remove the literature and parts packages. Wipe the interior of the drum thoroughly with a damp cloth.
3. Take two of the cardboard corners from the carton and place them on the floor in back of the dryer. Firmly grasp the body of the dryer and gently lay it on its back on the cardboard corners.
4. With one of the legs in hand, check the ridges for a diamond marking. That's how far the leg is supposed to go into the hole.
5. Start to screw the leveling legs into the holes by hand. (Use a small amount of liquid detergent to lubricate the screw threads so it is easier to turn the legs.) Use a 1-inch wrench or socket wrench to finish turning the legs until you reach the diamond mark.
Now stand the dryer up.
6. Remove the service door of the meter case by lifting it up at the back. Install the money-accepting device. (Refer to manufacturer's instructions for proper installation.)

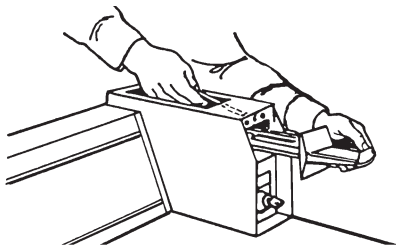

For dryers using coin slides, use adapter kit supplied with dryer.

7. Replace the meter case service door. Put the coin vault with lock and key in the meter case opening.
8. Remove cardboard or hardboard from under dryer.

Make Electrical Connection

Power Supply Cord Method

This dryer is manufactured with the neutral ground wire connected to the neutral (center) of the wiring harness at the terminal block. If local codes do not permit this type of connection, use "Four-wire connection" instructions.

Use a new UL-listed power supply cord rated 240-volt min., 30-amp and marked for use with a clothes dryer.

⚠️ WARNING



Fire Hazard

**Use a new UL listed 30 amp power supply cord.
Use a UL listed strain relief.
Disconnect power before making electrical connections.
Connect neutral wire (white or center wire) to center terminal (silver).
Earth wire (green or bare wire) must be connected to green earth connector.
Connect remaining 2 supply wires to remaining 2 terminals (gold).
Securely tighten all electrical connections.
Failure to do so can result in death, fire, or electrical shock.**

1. Disconnect power.

2. Remove hold-down screw and the terminal block cover.

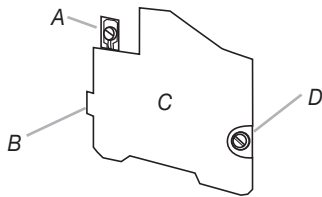

A. External ground conductor screw
 B. Tab
 C. Terminal block cover
 D. Hold-down screw

3. Assemble 3/4" UL-listed strain relief (UL marking on strain relief) into the hole below the terminal block opening. Tighten strain relief screws just enough to hold the two clamp sections together. Install power supply cord/cable through the strain relief.

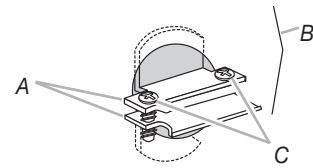

A. Strain relief clamp sections
 B. Dryer cabinet
 C. Strain relief screws

4. Complete installation following instructions for your type of electrical connection:

- Four-wire (recommended method)
- Three-wire (if four-wire is not available)

**Power Supply Cord,
 Four-wire electrical connection:**

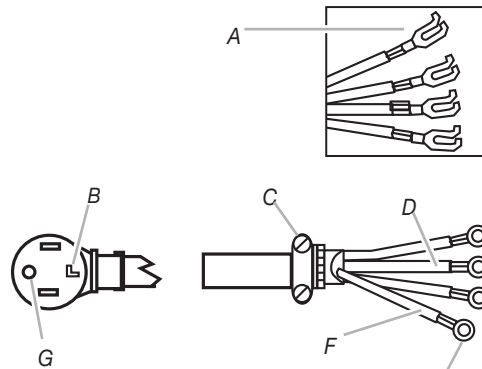

A. Spade terminals with upturned ends
 B. Neutral
 C. 3/4" UL-listed strain relief
 D. Neutral (white)
 E. Ring terminals
 F. Ground wire
 G. Ground prong

Four-wire power supply cord must have four, No.-10 copper wires and match a four-wire receptacle of NEMA Type 14-30R. The fourth wire (ground conductor) must be identified by a green cover and the neutral conductor by a white cover.

5. Remove the center terminal block screw.
6. Remove the appliance neutral ground wire from the external ground conductor screw. Fasten under center, silver-colored terminal block screw.
7. Connect the ground wire of the power supply cord to the external ground conductor screw. Tighten screw.
8. Connect the neutral wire (white or center) of the power supply cord under the center screw of the terminal block. Tighten screw.
9. Connect the other wires to outer terminal block screws. Tighten screws.
10. Tighten strain relief screws.
11. Insert tab of the terminal block cover into slot of the dryer rear panel. Secure cover with hold-down screw.

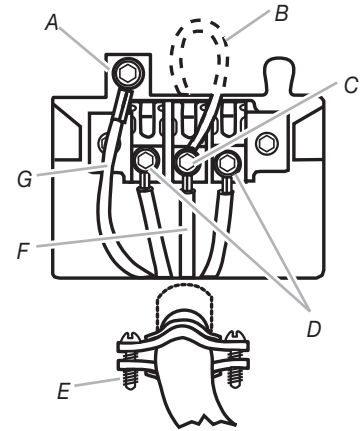

A. External ground conductor screw
 B. Appliance neutral ground wire
 C. Center terminal block screw
 D. Outer terminal block screws
 E. Strain relief screw
 F. Neutral (center wire)
 G. Ground wire

**Power Supply Cord,
Three-wire electrical connection:**

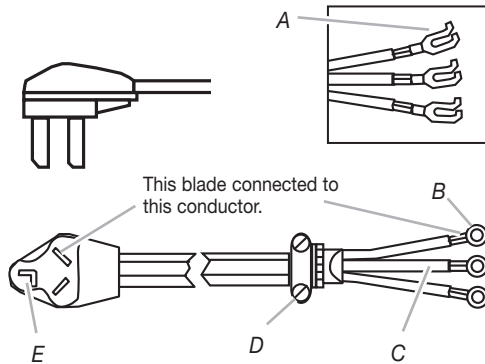

- A. Spade terminals with upturned ends
- B. Ring terminals
- C. Neutral (white or center)
- D. 3/4" UL-listed strain relief
- E. Neutral

Three-wire power supply cord must have three, No.-10 copper wires and match a three-wire receptacle of NEMA Type 10-30R.

Use this method where local codes permit connecting neutral ground wire to neutral wire:

5. Loosen or remove the center terminal block screw.
6. Connect the neutral wire (white or center) of the power supply cord to the center, silver-colored terminal screw of the terminal block. Tighten screw.
7. Connect the other wires to outer terminal block screws. Tighten screws.
8. Tighten strain relief screws.
9. Insert tab of the terminal block cover into slot of the dryer rear panel. Secure cover with hold-down screw.

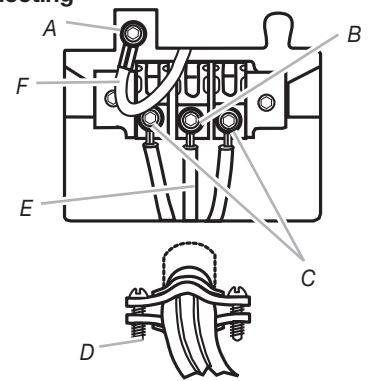

- A. External ground conductor screw
- B. Center terminal block screw
- C. Outer terminal block screws
- D. Strain relief screw
- E. Neutral (center wire)
- F. Appliance neutral ground wire

Use this method where local codes do not permit connecting neutral ground wire to neutral wire:

5. Remove the center terminal block screw.
6. Remove the appliance neutral ground wire from the external ground conductor screw. Connect the appliance neutral ground wire and the neutral wire (white or center) of the power supply cord under the center, silver-colored terminal block screw. Tighten screw.
7. Connect the other wires to outer terminal block screws. Tighten screws.
8. Tighten strain relief screws.
9. Insert tab of the terminal block cover into slot of the dryer rear panel. Secure cover with hold-down screw.
10. After reattaching the terminal cover, connect a separate copper ground wire from the external ground conductor screw to an adequate ground.

If codes permit and a separate ground wire is used, it is recommended that a qualified electrician determine that the ground path is adequate.

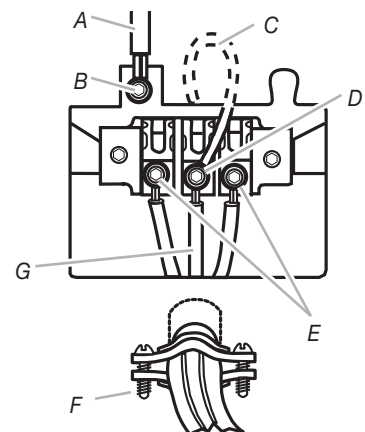

- A. Separate copper ground wire
- B. External ground conductor screw
- C. Appliance neutral ground wire
- D. Center terminal block screw
- E. Outer terminal block screws
- F. Strain relief screw
- G. Neutral (center wire)

Direct Wire Method

⚠ WARNING



Fire Hazard

Use 10 gauge copper wire.

Use a UL listed strain relief.

Disconnect power before making electrical connections.

Connect neutral wire (white or center wire) to center terminal (silver).

Ground wire (green or bare wire) must be connected to green ground connector.

Connect remaining 2 supply wires to remaining 2 terminals (gold).

Securely tighten all electrical connections.

Failure to do so can result in death, fire, or electrical shock.

Direct wire cable must match power supply (4-wire or 3-wire) and be:

- Flexible armored cable or nonmetallic sheathed copper cable (with ground wire), protected with flexible metallic conduit. All current-carrying wires must be insulated.
- 10-gauge solid copper wire (do not use aluminum).
- At least 5 ft. (1.52 m) long.

1. Disconnect power.

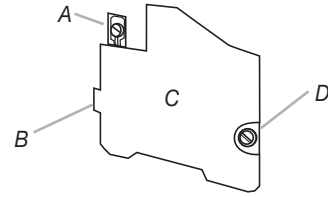

A. External ground conductor screw
B. Tab
C. Terminal block cover
D. Hold-down screw

2. Remove hold-down screw and the terminal block cover.
3. Install $\frac{3}{4}$ " conduit connector into the hole below the terminal block opening. Connect flexible metallic conduit and tighten connector screw. Install direct wire cable through the flexible

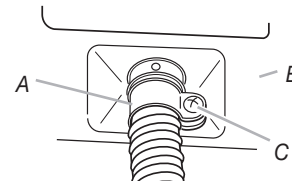

A. Conduit connector
B. Dryer cabinet
C. Connector screw

metallic conduit.

4. Complete installation following instructions for your type of electrical connection:
 - Four-wire (recommended method)
 - Three-wire (if four-wire is not available)

Direct Wire, Four-wire electrical connection:

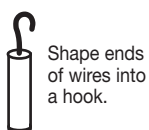
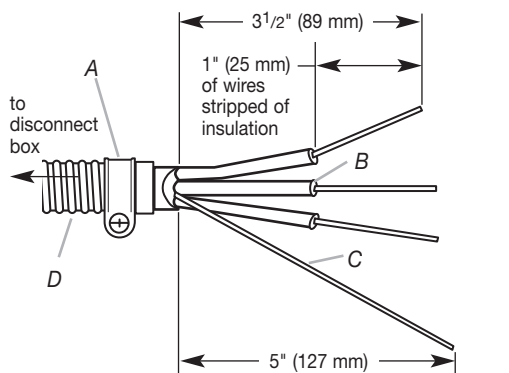

Shape ends of wires into a hook.

Strip 5" (127 mm) of outer covering from end of cable. Leave green or bare ground wire at 5" (127 mm). Cut $1\frac{1}{2}$ " (38 mm) from 3 remaining wires. Strip insulation back 1" (25 mm).

- A. $\frac{3}{4}$ " conduit connector
B. Neutral (white or center)
C. Ground wire (green or bare)
D. 10-gauge, 3 wire with ground wire in flexible metallic conduit

5. Remove the center terminal block screw.
6. Remove the appliance neutral ground wire from the external ground conductor screw. Fasten under center, silver-colored terminal block screw.
7. Connect the ground wire (green or bare) of the direct wire cable to the external ground conductor screw. Tighten screw.
8. Place the hooked end of the neutral wire (white or center) of the direct wire cable under the center screw of the terminal block (hook facing right). Squeeze hook end together. Tighten screw.
9. Place the hooked ends of the other direct wire cable wires under the outer terminal block screws (hook facing right). Squeeze hooked ends together. Tighten screws.
10. Insert tab of the terminal block cover into slot of the dryer rear panel. Secure cover with hold-down screw.

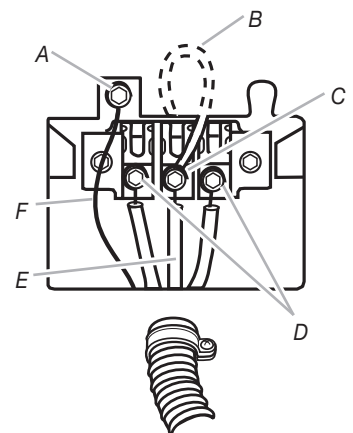

A. External ground conductor screw
B. Appliance neutral ground wire
C. Center terminal block screw
D. Outer terminal block screws
E. Neutral (center wire)
F. Green or bare ground wire

**Direct Wire,
Three-wire electrical connection:**

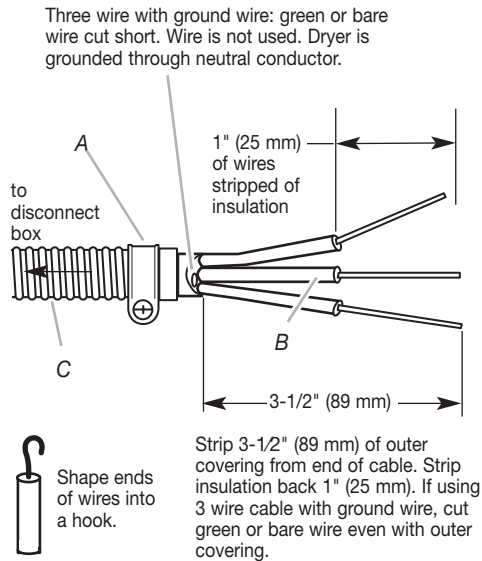

- A. 3/4" conduit connector
- B. Neutral (white or center)
- C. 10-gauge, 3 wire with ground wire in flexible metallic conduit

Use this method where local codes permit connecting neutral ground wire to neutral wire:

5. Loosen or remove the center terminal block screw.
6. Place the hooked end of the neutral wire (white or center) of the direct wire cable under the center screw of the terminal block (hook facing right). Squeeze hooked end together. Tighten screw.
7. Place the hooked ends of the other direct wire cable wires under the outer terminal block screws (hook facing right). Squeeze hooked ends together. Tighten screws.
8. Insert tab of the terminal block cover into slot of the dryer rear panel. Secure cover with hold-down screw.

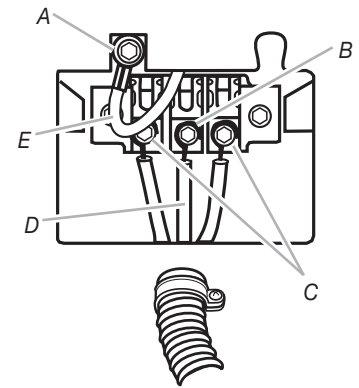

- A. External ground conductor screw
- B. Center terminal block screw
- C. Outer terminal block screws
- D. Neutral (center wire)
- E. Appliance neutral ground wire

Use this method where local codes do not permit connecting neutral ground wire to neutral wire:

5. Remove the center terminal block screw.
6. Remove the appliance neutral ground wire from the external ground conductor screw. Connect the appliance neutral ground wire and the neutral wire (white or center) of the direct wire cable under the center, silver-colored terminal block screw. Tighten screw.
7. Connect the other wires to outer terminal block screws. Tighten screws.
8. Insert tab of the terminal block cover into slot of the dryer rear panel. Secure cover with hold-down screw.
9. After reattaching the terminal cover, connect a separate copper ground wire from the external ground connector screw to an adequate ground.

If codes permit and a separate ground wire is used, it is recommended that a qualified electrician determine that the ground path is adequate.

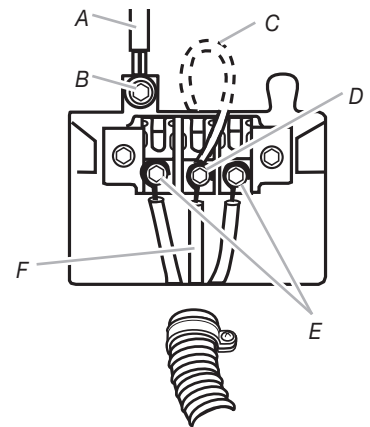

- A. Separate copper ground wire
- B. External ground conductor screw
- C. Appliance neutral ground wire
- D. Center terminal block screw
- E. Outer terminal block screws
- F. Neutral (center wire)

Connect Vent

1. Using a 4" (102 mm) clamp, connect vent to exhaust outlet in dryer. If connecting to existing vent, make sure the vent is clean. The dryer vent must fit over the dryer exhaust outlet and inside the exhaust hood. Make sure the vent is secured to exhaust hood with a 4" (102 mm) clamp.
2. Move dryer into final position. Do not crush or kink vent. Make sure dryer is level.

Complete Installation

1. With dryer in final position place level on top of the dryer, first side to side; then front to back. If the dryer is not level, adjust the legs of the dryer up or down until the dryer is level.

2. Plug in dryer or reconnect power.
3. Check dryer operation (some accumulated time may be on the timer due to factory testing).

Insert coins in slide and press slide in slowly. (Operating time will accumulate per number of coins and type of timing cam used.) Push START/RESTART button. Using a full heat cycle (not the air cycle), let the dryer run for at least five minutes. Dryer will stop when time is used up.

NOTE: Dryer door must be closed for dryer to operate. When door is open, dryer stops, but timer continues to run. To restart dryer, close door and push START/RESTART button.

4. If drying time is too long, make sure lint screen is clean.
5. Now start the dryer and allow it to complete a full heat cycle (not air cycle) to make sure it is working properly.

CHANGING TO A 30- OR 60-MINUTE TIMING CAM

⚠ WARNING



Electrical Shock Hazard

Disconnect power before making cam changes.

Failure to follow these instructions can result in death or electrical shock.

You can install the 30-minute or 60-minute timing cam (shipped with dryer) as follows:

1. Unplug dryer or disconnect power.
2. Unlock meter case.
3. Turn the timing cam by hand until the V-shaped notch lines up below the ratchet tooth.
4. Insert a narrow, flat-blade screwdriver under the timing cam near the clock shaft. Gently lift cam straight up and off shaft making sure that the V-shaped notch clears the ratchet tooth.

5. Place new cam (hub side down) over clock shaft. Line up flat side of shaft with flat side of cam hole. Check that drive lug is in place.

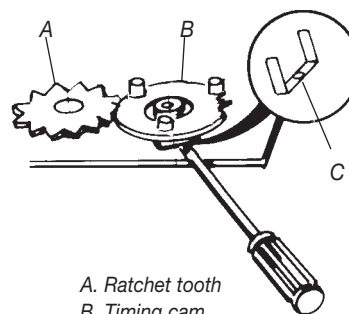

A. Ratchet tooth
B. Timing cam
C. Drive lug

6. Turn cam until V-shaped notch lines up with ratchet tooth.
7. Press cam down in place on clock shaft. Make sure that V-shaped notch clears the ratchet tooth.
8. Close and lock the meter case.
9. Plug in dryer or reconnect power.

Maintenance instructions:

- Clean lint screen before each cycle.
- Removing accumulated lint:
 - From inside the dryer cabinet:

Lint should be removed every 2 years or more often, depending on dryer usage. Cleaning should be done by a qualified person.
 - From the exhaust vent:

Lint should be removed every 2 years, or more often, depending on dryer usage.

If dryer does not operate check the following:

- Electric supply is connected.
- Circuit breakers are not tripped or fuses are not blown.
- Door is closed.
- Controls are set in a running or "ON" position.
- START button has been pushed firmly.
- For gas dryers, check that gas supply shutoff valves are set in open position.

If you need assistance:

The Commercial Laundry Support Center will answer any questions about operating or maintaining your dryer not covered in the Installation Instructions. The Commercial Laundry Support Center is open 24 hours a day, 7 days a week. Just dial 1-800 NO BELTS (1-800-662-3587) — the call is toll free.

When you call, you will need the dryer model number and serial number. Both numbers can be found on the serial-rating plate located in the dryer door well.