

PORTER CABLE®

PIN NAILER

Cloueuse de goupilles

Clavadora

Instruction manual

Manuel d'instructions

Manual de instrucciones

Française : Page 15

Español: Página 30

www.deltaportercable.com

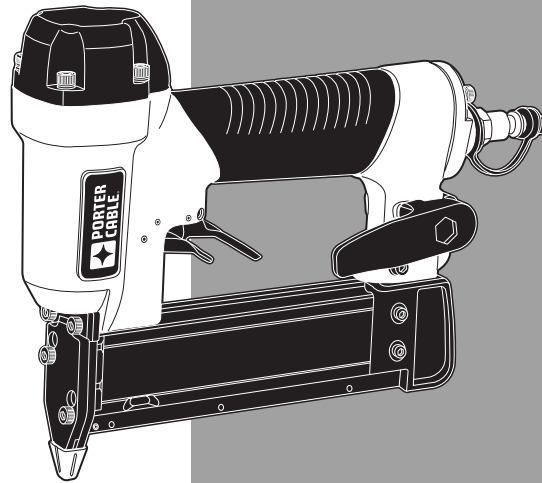

INSTRUCTIVO DE OPERACIÓN, CENTROS
DE SERVICIO Y PÓLIZA DE GARANTÍA.

▲ ADVERTENCIA: LÉASE ESTE INSTRUCTIVO
ANTES DE USAR EL PRODUCTO.

PIN138

IMPORTANT SAFETY INSTRUCTIONS FOR PNEUMATIC TOOLS

SAVE THESE INSTRUCTIONS

⚠ WARNING: When using any pneumatic tool, all safety precautions, as outlined below, should be followed to avoid the risk of death or serious injury. Read all instructions before operating the tool.

DEFINITIONS - SAFETY GUIDELINES

The definitions below describe the level of severity for each signal word. Please read the manual and pay attention to these symbols.

⚠ DANGER : Indicates an imminently hazardous situation which, if not avoided, **will** result in **death or serious injury**.

⚠ WARNING: Indicates a potentially hazardous situation which, if not avoided, **could** result in **death or serious injury**.

⚠ CAUTION: Indicates a potentially hazardous situation which, if not avoided, **may** result in **minor or moderate injury**.

NOTICE : Indicates a practice **not related to personal injury** which, if not avoided, **may** result in **property damage**.

- **Actuating tool may result in flying debris, collation material, or dust which could harm operator's eyes. Operator and others in work area MUST wear safety glasses with side shields.** These safety glasses must conform to ANSI Z87.1 requirements (approved glasses have "Z87" printed or stamped on them). It is the employer's responsibility to enforce the use of eye protection equipment by the tool operator and other people in the work area. (Fig. A)
- **Always wear appropriate personal hearing and other protection during use. Under some conditions and duration of use, noise from this product may contribute to hearing loss.** (Fig. A)
- Use only clean, dry, regulated air. Condensation from an air compressor can rust and damage the internal workings of the tool. (Fig. B)
- Regulate air pressure. **Use air pressure compatible with ratings on the nameplate of the tool.** [Not to exceed 100 psi (6.9 bar).] Do not connect the tool to a compressor rated at over 175 psi. The tool operating pressure must never exceed 175 psi even in the event of regulator failure. (Fig. C)
- **Only use air hose that is rated for a maximum working pressure of at least 150 psi (10.3 bar) or 150% of the maximum system pressure, which ever is greater.** (Fig. D)



Fig. A

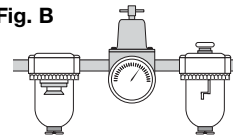

Fig. B

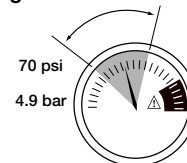
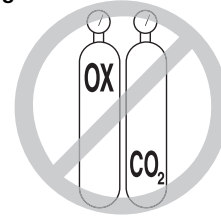

Fig. C

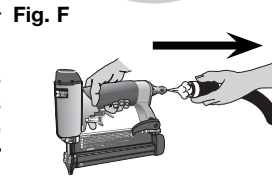

Fig. D

- **Do not use bottled gases to power this tool. Bottled compressed gases such as oxygen, carbon dioxide, nitrogen, hydrogen, propane, acetylene or air are not for use with pneumatic tools.** Never use combustible gases or any other reactive gas as a power source for this tool. Danger of explosion and/or serious personal injury may result. (Fig. E)



- Use couplings that relieve all pressure from the tool when it is disconnected from the power supply. Use hose connectors that shut off air supply from compressor when the tool is disconnected. (Fig. F)



- Disconnect tool from air supply when not in use. **Always disconnect tool from air supply and remove fasteners from magazine before leaving the area or passing the tool to another operator. Do not carry tool to another work area in which changing location involves the use of scaffoldings, stairs, ladders, and the like, with air supply connected. Do not make adjustments, remove magazine, perform maintenance or clear jammed fasteners while connected to the air supply.** (Fig. G)

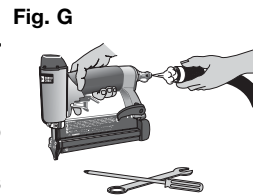

- **Connect tool to air supply before loading fasteners to prevent a fastener from being fired during connection. The tool driving mechanism may cycle when tool is connected to the air supply.** Do not load fasteners with trigger or safety trigger depressed to prevent unintentional firing of a fastener.



- Do not remove, tamper with, or otherwise cause the tool or trigger to become inoperable. Do not tape or tie trigger in the on position. Make daily inspections for free movement of trigger. Uncontrolled discharge could result.

- **Inspect tool before use. Do not operate a tool if any portion of the tool or trigger is inoperable, disconnected, altered, or not working properly.** Leaking air, damaged parts or missing parts should be repaired or replaced before use. Refer to *Repairs*. (Fig. H)

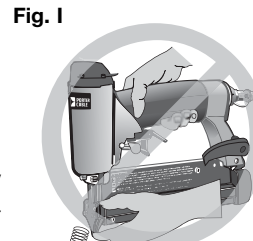

- **Do not alter or modify the tool in any way.** (Fig. I)
- **Always assume that the tool contains fasteners.**
- **Do not point the tool at co-workers or yourself at any time. No horseplay!** Work safe! Respect the tool as a working implement. (Fig. J)

- **Keep bystanders, children, and visitors away while operating a power tool. Distractions can cause you to lose control.** When tool is not in use, it should be locked in a safe place, out of the reach of children.



- **Remove finger from trigger when not driving fasteners.**
- **Never carry tool with finger on trigger. Accidental discharge could result.**

- **Do not overreach. Maintain proper footing and balance at all times.** Loss of balance may cause personal injury. (Fig. K)
- **Make sure hose is free of obstructions or snags.** Entangled or snarled hoses can cause loss of balance or footing.
- **Use the tool only for its intended use. Do not discharge fasteners into open air, concrete, stone, extremely hard woods, knots or any material too hard for the fastener to penetrate.** Do not use the body of the tool or top cap as a hammer. Discharged fasteners may follow unexpected path and cause injury. (Fig. L)
- Always keep fingers clear of nosepiece to prevent injury from inadvertent release of nails. (Fig. M)
- Refer to the **Maintenance and Repairs** sections for detailed information on the proper maintenance of the tool.
- **Always operate the tool in a clean, lighted area. Be sure the work surface is clear of any debris and be careful not to lose footing when working in elevated environments such as rooftops.**
- **Do not drive fasteners near edge of material. The workpiece may split causing the fastener to ricochet, injuring you or a co-worker.** Be aware that the nail may follow the grain of the wood (shiner), causing it to protrude unexpectedly from the side of the work material. Drive the nail perpendicular to the grain to reduce risk of injury. (Fig. N)
- **Do not drive nails onto the heads of other fasteners or with the tool at too steep an angle. Personal injury from strong recoil, jammed fasteners, or ricocheted nails may result.** (Fig. O)
- Be aware of material thickness when using the nailer. **A protruding nail may cause injury.**
- **Be aware that when the tool is being utilized at pressures on the high end of its operating range, nails can be driven completely through thin or very soft work material. Make sure the pressure in the compressor is set so that nails are set into the material and not pushed completely through.** (Fig. P)
- **Keep hands and body parts clear of immediate work area. Hold workpiece with clamps when necessary to keep hands and body out of potential harm.** Be sure the workpiece is properly secured before pressing the nailer against the material. (Fig. Q)
- Do not use tool in the presence of flammable dust, gases or fumes. The tool may produce a spark that could ignite gases causing a fire. Driving a nail into another nail may also cause a spark. (Fig. R)
- Keep face and body parts away from back of the tool cap when working in restricted areas. **Sudden recoil can result in impact to the body, especially when nailing into hard or dense material.** (Fig. S)

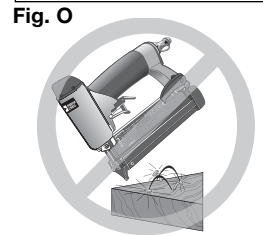
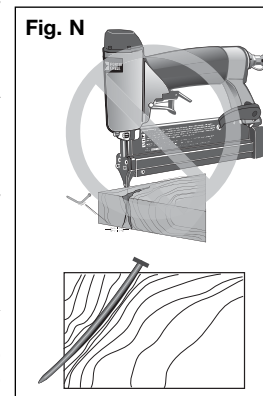
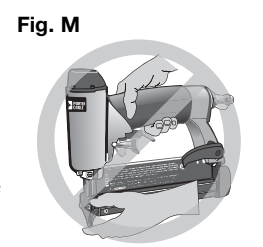
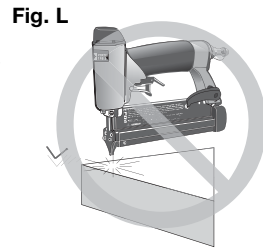
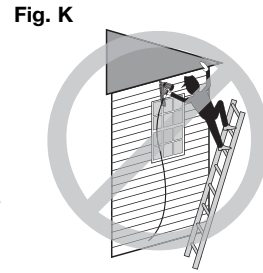

- **Grip tool firmly to maintain control while allowing tool to recoil away from work surface as fastener is driven.**
- **Do not actuate the tool unless the tool is placed firmly against the workpiece.** (Fig. T)
- **DEPTH ADJUSTMENT:** To reduce risk of serious injury from accidental actuation when attempting to adjust depth, **ALWAYS:**
 - Disconnect air supply.
 - Avoid contact with trigger during adjustments.
- **Do not drive nails blindly into walls, floors or other work areas. Fasteners driven into live electrical wires, plumbing, or other types of obstructions can result in injury.** (Fig. U)
- **Stay alert, watch what you are doing and use common sense when operating a power tool. Do not use tool while tired or under the influence of drugs or alcohol.** A moment of inattention while operating power tools may result in serious personal injury.

Fig. P

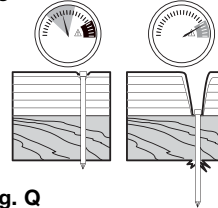

Fig. Q



Fig. R

⚠ WARNING: Some dust created by power sanding, sawing, grinding, drilling, and other construction activities contains chemicals known to the State of California to cause cancer, birth defects or other reproductive harm. Some examples of these chemicals are:

- lead from lead-based paints,
- crystalline silica from bricks and cement and other masonry products, and
- arsenic and chromium from chemically-treated lumber.

Your risk from these exposures varies, depending on how often you do this type of work. To reduce your exposure to these chemicals: work in a well ventilated area, and work with approved safety equipment, such as those dust masks that are specially designed to filter out microscopic particles.

⚠ WARNING: Use of this tool can generate and/or disburse dust, which may cause serious and permanent respiratory or other injury. Always use NIOSH/OSHA approved respiratory protection appropriate for the dust exposure. Direct particles away from face and body. Always operate tool in well-ventilated area and provide for proper dust removal. Use dust collection system wherever possible.

⚠ WARNING: ALWAYS USE SAFETY GLASSES. Everyday eyeglasses are NOT safety glasses. Also use face or dust mask if operation is dusty. ALWAYS WEAR CERTIFIED SAFETY EQUIPMENT:

- ANSI Z87.1 eye protection (CAN/CSA Z94.3),
- ANSI S12.6 (S3.19) hearing protection,
- NIOSH/OSHA respiratory protection.

Before operating this tool, carefully read all instructions in *Important Safety Instructions*.



Fig. S

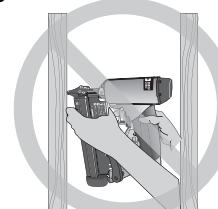

Fig. T



Fig. U



SAVE THESE INSTRUCTIONS

NAIL SPECIFICATIONS	
	PIN138
Nails	23 gauge wire (headless or slight head pins)
Lengths	5/8" (16 mm) –1-3/8" (35 mm)
Air Inlet	1/4" NPT (6.4 mm)
NOTE: Use only PORTER-CABLE approved fasteners	

TOOL PARTS

Fig. 1

- A. Trigger
- B. Safety trigger
- C. Air Inlet with quick connect coupler
- D. Rear exhaust
- E. Magazine release
- F. Magazine
- G. Low nail indicator window
- H. Nosepiece
- I. No-Mar pad
- J. Belt hook

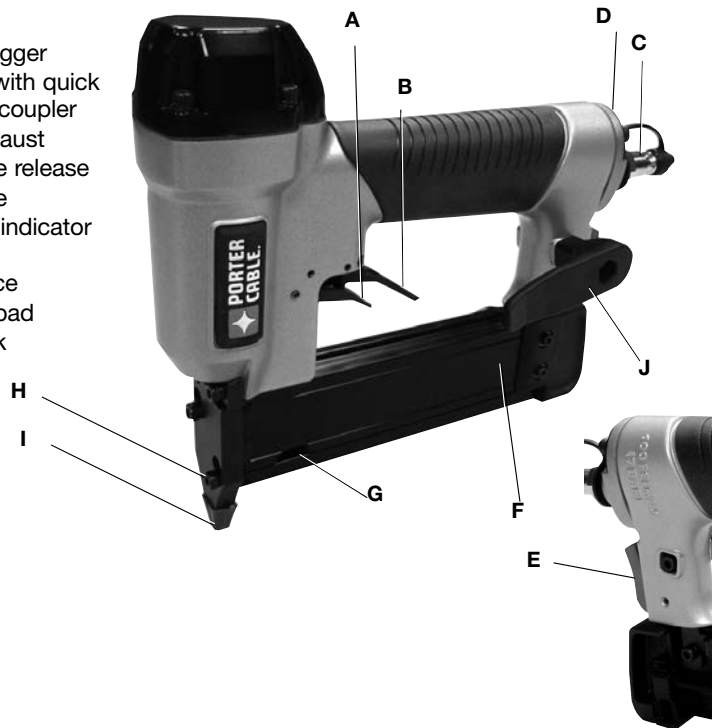

ASSEMBLY

⚠ WARNING: Disconnect air line from tool and remove fasteners from magazine before making adjustments or personal injury may result.

TRIGGER

⚠ WARNING: Keep fingers AWAY from trigger when not driving fasteners to avoid accidental firing. Never carry tool with finger on trigger.

The tool is shipped from the factory with a dual trigger actuation system.

AIR FITTING

The tool is equipped with a 1/4" (6.4 mm) male quick connector coupling. A 3/8" (9.5 mm) male quick connector coupling is available from PORTER-CABLE and may be used when a 1/4" (6.4 mm) supply line is not available.

NOTE: A 3/8" (9.5 mm) supply line (and fittings) are required for maximum tool performance. **IMPORTANT:** Always use couplings that relieve all pressure from the tool when it is disconnected from the power supply. Always use hose connectors that shut off air supply from compressor when the tool is disconnected.

To install an air fitting

1. Wrap the male end of the fitting with thread seal tape prior to assembly to eliminate air leaks.
2. To install a 1/4" (6.4 mm) fitting: screw it directly into the air inlet and tighten firmly.
NOTE: If a cap is in the air inlet, remove it prior to inserting the fitting.
3. To install a 3/8" (9.5 mm) fitting: screw the fitting into the 3/8" (9.5 mm) adapter and then into the air inlet of the tool and tighten firmly.

OPERATION

PREPARING THE TOOL

▲WARNING: Read the section titled **Important Safety Instructions for Pneumatic Tools** at the beginning of this manual. Always wear eye and ear protection when operating this tool. Keep the nailer pointed away from yourself and others. For safe operation, complete the following procedures and checks before each use of the nailer.

NOTE: These nailers are designed to be used without oil.

1. Before you use the nailer, be sure that the compressor tanks have been properly drained. **NOTE:** Use a filter and regulator when possible.
2. Wear proper eye, hearing and respiratory protection.
3. Ensure magazine is empty of all fasteners.
4. Check for proper operation of trigger and safety trigger. Do not use tool if assembly is not functioning properly.
5. Check air supply: Ensure air pressure does not exceed recommended operating limits; 60 to 100 psi, (4.1 to 6.9 bar).
6. Keep tool pointed away from yourself and others.
7. Connect air hose.
8. Check for audible leaks around valves and gaskets. Never use a tool that leaks or has damaged parts.

▲WARNING: To reduce the risk of personal injury, disconnect tool from air supply before performing maintenance, clearing a jammed fastener, leaving work area, moving tool to another location or handing the tool to another person.

Using the Lock-off (Fig. 1)

▲WARNING: To reduce the risk of injury. **ALWAYS** wear proper eye [ANSI Z87.1 (CAN/CSA Z94.3)] and hearing protection [ANSI S12.6 (S3.19)] when operating this tool.

▲WARNING: Keep fingers AWAY from triggers when not driving fasteners to avoid accidental firing. Never carry tool with finger on triggers.

▲WARNING: Disconnect air line from tool and remove fasteners from magazine before making adjustments or personal injury may result.

The trigger is locked off until the safety trigger is depressed.

LOADING THE TOOL (FIG. 1-3)

⚠ WARNING: Keep the tool pointed away from yourself and others. Serious personal injury may result.

⚠ WARNING: Never load nails with the trigger activated. Personal injury may result.

1. Read all **Safety Warnings** before using tool.
2. Connect the tool to air supply.
3. Push magazine release (E) and pull magazine (F) back. Make sure safety trigger has the trigger locked off.
4. Insert fasteners into the side of the magazine (K). For fasteners with arrows the direction arrow printed on the fasteners should point down into the bottom of magazine. If no arrow is printed on the fasteners the nail points should point down into the bottom of the magazine. **NOTE:** Make sure fasteners are placed firmly against lower ledge of magazine.
5. Push magazine closed until it locks in place. Make sure the magazine snaps into place.
6. Observe low nail indicator window (G) and reload when needed.

NOTE: The tool will not fire when only a few fasteners are left in the magazine, reload fasteners to begin firing again.

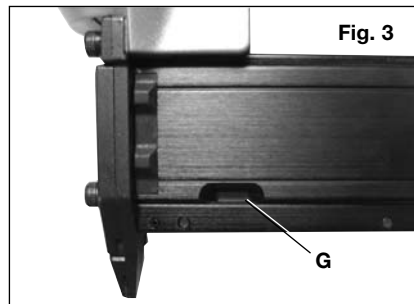
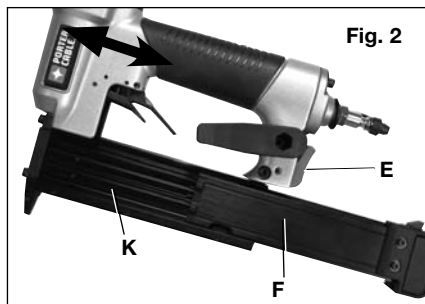

ACTUATING TOOL (1, 4)

⚠ WARNING: To reduce the risk of injury, **ALWAYS** wear proper eye [ANSI Z87.1 (CAN/CSA Z94.3)] and hearing protection [ANSI S12.6 (S3.19)] when operating this tool.

⚠ WARNING: A nail will fire each time the trigger is depressed which could result in accidental actuation.

1. Place the nosepiece against the work surface.
2. Depress the safety trigger (B) to unlock the trigger (A). Now depress the trigger (A). A fastener is fired each time the trigger is depressed.

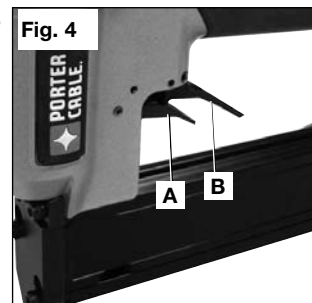

CAUTION: Each time a fastener is fired, a blast of air will be exhausted from the rear exhaust (D). Keep your face away from this area.

ADJUSTING DEPTH

The depth that a fastener is driven is controlled by the pressure of the air supply. The amount of air pressure required will vary depending on the length of the fastener and the material being fastened. Experiment with the air pressure setting to determine the lowest setting that will consistently perform the job at hand.

CAUTION: Air pressure in excess of that required can cause premature wear and/or damage to the tool.

NO-MAR PAD AND WRENCH STORAGE (FIG. 5, 6)

WARNING: Disconnect tool from air supply before removing or re-installing no-mar pad.

The no-mar pad (I) is provided to reduce marring of the work surface. The no-mar pad can be removed, and stored on the bracket (M), to provide increased depth-of-drive for toe-nailing applications.

When not in use the hex wrench (L) supplied can be snapped into the storage bracket as shown.

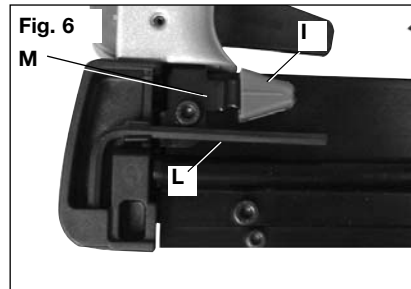
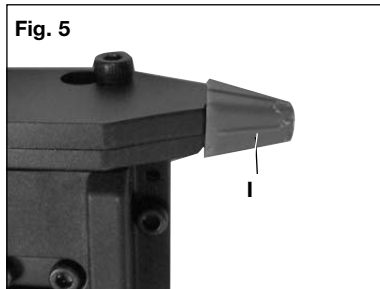

CLEARING A JAMMED NAIL (FIG. 1, 7)

WARNING: Disconnect air line from tool and remove fasteners from magazine before making adjustments or personal injury may result.

If a nail becomes jammed in the nosepiece, keep the tool pointed away from you and follow these instructions to clear:

1. Make sure safety trigger (B) has the trigger (A) locked off.
2. Disconnect air supply from tool.
3. Push magazine release (E) and pull magazine (F) back. Remove fasteners.
4. Remove no-mar pad (I) and then using 3 mm hex wrench to remove two bolts (O) and nosepiece (H).
5. Remove the jammed fastener.
6. Examine the feed track and clear any damaged pins or pin fragments.
7. Replace nosepiece and tighten bolts securely.
8. Reattach air supply.
9. Reload the tool (see **Loading the Tool**).

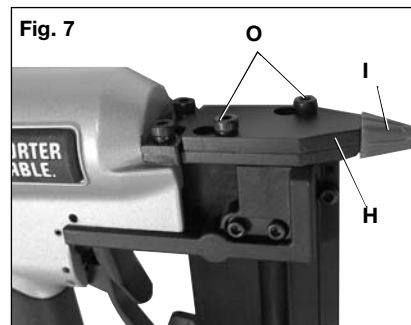

NOTE: Should nails continue to jam frequently in nosepiece, have tool serviced by an authorized PORTER-CABLE service center.

COLD WEATHER OPERATION

When operating tools at temperatures below freezing:

1. Make sure compressor tanks have been properly drained prior to use.
2. Keep tool as warm as possible prior to use.
3. Make certain all fasteners have been removed from magazine.
4. Lower air pressure to 80 psi or less.
5. Reconnect air and load nails into magazine.
6. Turn pressure up to operating level (not to exceed 100 psi) and use tool as normal.
7. Always drain the compressor tanks at least once a day.

HOT WEATHER OPERATION

Tool should operate normally. However, keep tool out of direct sunlight as excessive heat can deteriorate bumpers, O-rings and other rubber parts resulting in increased maintenance.

BELT HOOK (FIG. 1, 8)

The integrated belt hook (J) can be assembled to either side of the tool to accommodate left- or right- handed users. If the hook is not desired at all, it can be removed from the tool.

To remove or assemble belt hook

1. Make sure safety trigger (B) has the trigger (A) locked off.
2. Disconnect the tool from air supply.
3. Using the appropriate hex wrench, remove the belt hook (J).
4. Assemble belt hook to other side of nailer in hole (P) and tighten screw securely.

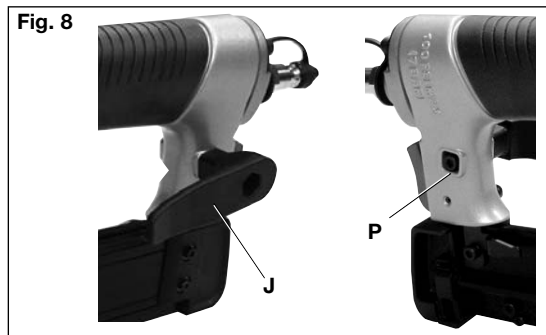

MAINTENANCE

⚠ WARNING: Disconnect air line from tool and remove fasteners from magazine before making adjustments or personal injury may result.

DAILY MAINTENANCE CHART

ACTION	WHY	HOW
Drain compressor tanks and hoses daily.	Prevents accumulation of moisture in compressor and nailer.	Open petcocks or other drain valves on compressor tanks. Allow any accumulated water to drain from hoses.
Clean magazine and magazine release.	Permits smooth operation of magazine, reduces wear and prevents jams.	Blow clean with compressor air. The use of oils, lubricants periodically or solvents is not recommended as they tend to attract debris.
Before each use, check to insure all screws, nuts and fasteners are tight and undamaged.	Prevents jams, leaks and premature failure of tool parts.	Tighten loose screws or other fasteners using the appropriate hex wrench or screwdriver.

CLEANING

⚠ WARNING: Never use solvents or other harsh chemicals for cleaning the non-metallic parts of the tool. These chemicals may weaken the materials used in these parts. Use a cloth dampened only with water and mild soap. Never let any liquid get inside the tool; never immerse any part of the tool into a liquid.

REPAIRS

For assistance with your tool, visit our website at www.deltaportercable.com for a list of service centers, or call the PORTER-CABLE Customer Care Center at (888) 848-5175.

SERVICE

REPLACEMENT PARTS

Use only identical replacement parts. For a parts list or to order parts, visit our service website at www.deltaportercableservicenetwork.com. You can also order parts from your nearest PORTER-CABLE Factory Service Center or PORTER-CABLE Authorized Warranty Service Center. Or, you can call our Customer Care Center at (888) 848-5175.

SERVICE AND REPAIRS

All quality tools will eventually require servicing and/or replacement of parts. For information about PORTER-CABLE, its factory service centers or authorized warranty service centers, visit our website at www.deltaportercable.com or call our Customer Care Center at (888) 848-5175. All repairs made by our service centers are fully guaranteed against defective material and workmanship. We cannot guarantee repairs made or attempted by others.

You can also write to us for information at PORTER-CABLE, 4825 Highway 45 North, Jackson, Tennessee 38305 - Attention: Product Service. Be sure to include all of the information shown on the nameplate of your tool (model number, type, serial number, etc.).

ACCESSORIES

⚠ WARNING: Since accessories, other than those offered by PORTER-CABLE, have not been tested with this product, use of such accessories with this tool could be hazardous. To reduce the risk of injury, only PORTER-CABLE recommended accessories should be used with this product.

A complete line of accessories is available from your PORTER-CABLE Factory Service Center or a PORTER-CABLE Authorized Warranty Service Center. Please visit our Web Site www.deltaportercable.com for a catalog or for the name of your nearest supplier.

THREE YEAR LIMITED WARRANTY

PORTER-CABLE will repair, without charge, any defects due to faulty materials or workmanship for three years from the date of purchase. This warranty does not cover part failure due to normal wear or tool abuse. For further detail of warranty coverage and warranty repair information, visit www.deltaportercable.com or call (888) 848-5175. This warranty does not apply to accessories or damage caused where repairs have been made or attempted by others. This warranty gives you specific legal rights and you may have other rights which vary in certain states or provinces.

In addition to the warranty, PORTER-CABLE tools are covered by our:

1 YEAR FREE SERVICE: PORTER-CABLE will maintain the tool and replace worn parts caused by normal use, for free, any time during the first year after purchase.

90 DAY MONEY BACK GUARANTEE: If you are not completely satisfied with the performance of your PORTER-CABLE Power Tool, Laser, or Nailer for any reason, you can return it within 90 days from the date of purchase with a receipt for a full refund – no questions asked.

LATIN AMERICA: This warranty does not apply to products sold in Latin America. For products sold in Latin America, see country specific warranty information contained in the packaging, call the local company or see website for warranty information.

To register your tool for warranty service visit our website at www.deltaportercable.com.

WARNING LABEL REPLACEMENT

If your warning labels become illegible or are missing, call (888) 848-5175 for a free replacement.

	Model PIN138 1 3/8" (35 mm) 23 Ga. (.9mm) FINISH NAILER						
	⚠ WARNING Read and understand tool labels and manual. Failure to follow warnings could result in DEATH or SERIOUS INJURY. Operators and others in work area MUST wear ANSI Z87.1 safety glasses with side shields. Keep fingers AWAY from trigger when not driving fasteners to avoid accidental firing. Choice of triggering method is important. Check manual for triggering options. Never disable trigger. Ensure trigger operates properly before use. NEVER point tool at yourself or others in work area. NEVER use oxygen or other bottled gasses. Explosion may occur. Disconnect air before servicing tool, clearing jams, and adjusting depth. PORTER-CABLE, JACKSON, TN 38305 U.S.A.						
	Operating Pressure: <table border="1"> <tr> <td>MIN.</td> <td>MAX.</td> </tr> <tr> <td>60</td> <td>100</td> </tr> <tr> <td>4.1</td> <td>6.9</td> </tr> </table> PSI BAR	MIN.	MAX.	60	100	4.1	6.9
	MIN.	MAX.					
60	100						
4.1	6.9						
	Fastener Length: <table border="1"> <tr> <td>MIN.</td> <td>MAX.</td> </tr> <tr> <td>5/8"</td> <td>1 3/8"</td> </tr> <tr> <td>16mm</td> <td>25mm</td> </tr> </table>	MIN.	MAX.	5/8"	1 3/8"	16mm	25mm
	MIN.	MAX.					
5/8"	1 3/8"						
16mm	25mm						
USES HEADLESS & SLIGHT HEAD NAILS							

⚠ ADVERTENCIA Por favor lea y comprenda las etiquetas y el manual de la herramienta. El no cumplir con las advertencias, podría resultar en serias lesiones personales o la muerte. Los operarios y demás personas en el área de trabajo deberán llevar anteojos de seguridad ANSI Z87.1 con protección lateral. A fin de evitar el disparo accidental, mantenga los dedos alejados del gatillo cuando no está clavando. Es importante escoger el método de disparo. Verifique las opciones que ofrece el manual. Nunca deshabilite el gatillo. Asegúrese de que el gatillo trabaje apropiadamente antes de utilizar la herramienta. La herramienta jamás se deberá apuntar hacia uno mismo ni hacia las demás personas en el área de trabajo. Nunca utilice oxígeno ni demás gases embotellados que puedan explotar. Desconecte la alimentación de aire antes de revisar la herramienta, antes de desatascar los sujetadores o de ajustar la profundidad.

⚠ AVERTISSEMENT Lire et comprendre les étiquettes de l'outil ainsi que le guide d'utilisation. Le non-respect des avertissements présente des risques de décès ou de blessures graves. Les personnes qui utilisent l'outil et les personnes qui se trouvent dans la zone de travail doivent porter des lunettes de sécurité à écran latéral conformes à la norme ANSI Z87.1. Éloigner les doigts de la détente lorsqu'on n'a fonction pas d'attaches afin d'éviter le fonctionnement accidentel de l'outil. Le choix de la méthode d'agrafage est important. Vérifier les options de détente dans le guide d'utilisation. Ne jamais désactiver la détente. S'assurer que le déclencheur fonctionne correctement avant d'utiliser l'outil. Ne jamais pointer l'outil vers soi ou vers d'autres personnes dans la zone de travail. Ne jamais utiliser de l'oxygène ni d'autres gaz embouteillés; cela présente un risque d'explosion. Débrancher l'alimentation en air avant de faire l'entretien de l'outil, de dégager l'outil et d'un régler la profondeur.

TROUBLESHOOTING GUIDE

MANY COMMON PROBLEMS CAN BE SOLVED EASILY BY UTILIZING THE CHART BELOW. FOR MORE SERIOUS OR PERSISTENT PROBLEMS, CONTACT A PORTER-CABLE SERVICE CENTER OR CALL 1 888 848-5175.





⚠ WARNING: To reduce the risk of serious personal injury, **ALWAYS** disconnect air from tool before all repairs.

SYMPTOM	PROBLEMS	SOLUTIONS
Air leak near top of tool or in trigger area	Loose screws.	Tighten screws.
	Worn or damaged o-rings or seals.	Install Overhaul Kit (Part # 60117).
Tool does nothing or operates sluggishly	Inadequate air supply.	Verify adequate air supply.
	Worn or damaged o-rings or seals.	Install Overhaul Kit (Part # 60117).
	Fastener jammed in nosepiece.	See Clearing a Jammed Nail .
Air leak near bottom of tool	Loose screws.	Tighten screws.
	Worn or damaged o-rings or bumper.	Install Overhaul Kit (Part # 60117).
Tool jams frequently	Incorrect fasteners.	Verify approved fasteners of correct size.
	Fastener fragments jammed in nosepiece.	See Clearing a Jammed Nail .
	Fasteners loaded incorrectly.	Verify fasteners are loaded correctly. See To Load Tool .
	Damaged fasteners.	Replace damaged fasteners. See To Load Tool .
	Magazine or nose screws loose	Tighten screws.
	Magazine is dirty.	Clean magazine.
	Driver tip is worn or damaged.	Install Driver Maintenance (Part # 60118).
Tool does not fire	Only a few fasteners are left in the magazine	Reload fasteners to begin firing again.
Other		Contact a PORTER-CABLE Authorized Warranty Service Center

TOOL SPECIFICATIONS

	PIN138
Height (inch/meter)	7.5/.19
Width (inch/meter)	1.9/.05
Length (inch/meter)	8.1/.21
Weight (lbs/kg)	2.1/0.95
Recommended Operating Pressure	60-100 psi (4.1 to 6.9 bar)
Air Consumption per 100 cycles	1.61 SCF
Loading capacity	132 nails
Lubrication	Oil-Free

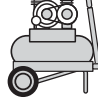
	Compressor will be sufficient for tools at all production rates.
	Compressor will be sufficient at slow or moderate production rates, but may have difficulty at very rapid rates.
	Compressor will be adequate only when tools are utilized at slow production rates (punch-out or occasional use).
NR	Not Recommended

		Portable Handcarry 3.2 – 4 CFM	5.5 HP Gas 2 HP Elec. 8 – 9 CFM	8 HP Gas 14 – 16 CFM	Industrial 23+ CFM
					
NUMBER OF TOOLS CONNECTED TO COMPRESSOR	1				
	2				
	3				
	4	NR			
	5	NR			
	6	NR	NR		
	7	NR	NR		
	8+	NR	NR		