



English
Français
Español

ASSEMBLY INSTRUCTIONS
INSTRUCTIONS DE MONTAGE
INSTRUCCIONES PARA EL ENSAMBLAJE



Ø 8x300 12x120 14x150 mm
 D. $\frac{2}{64} \times 11\frac{3}{4}$ " - $\frac{15}{32} \times 4\frac{3}{4}$ " - $\frac{9}{16} \times 5\frac{7}{8}$ " in

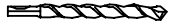

Ø 2.5 3.5 4.5 9 mm
 D. $\frac{3}{32}$ " - $\frac{9}{64}$ " - $\frac{11}{64}$ " - $\frac{23}{64}$ " in



PH 2

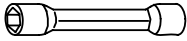

12 mm 13 mm
 $\frac{15}{32}$ " in $\frac{33}{64}$ " in

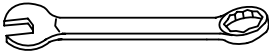

13 17 19 30 mm
 $\frac{33}{64}$ " - $\frac{43}{64}$ " - $\frac{3}{4}$ " - $\frac{3}{16}$ " in



2.5 3 5 12 mm
 $\frac{3}{32}$ " - $\frac{1}{8}$ " - $\frac{13}{64}$ " - $\frac{15}{32}$ " in

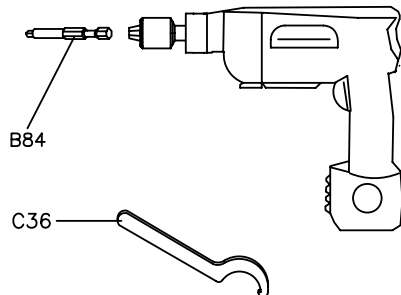
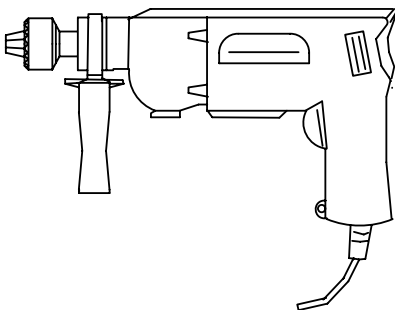
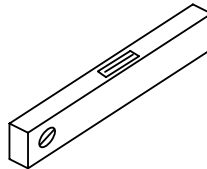
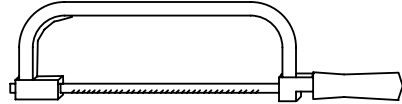

English

WARNING: Carry out the installation in a "workmanlike" manner, strictly following the installation instructions and using suitable tools. Always consult your local building department for code requirements that must be respected depending on its destination of use (private, secondary, public...).

Before starting the assembly process, unpack all components of the staircase. Lay them out on a large surface and check the quantity of all the pieces, by consulting the table (TAB.1: A = Code, B = Quantity).

For the USA only: call the customer support line at 1-888 STAIRKT, should you have any case of need.

Preliminary Assembly

1. Screw the parts D32 and D33 into the treads (L02) (fig. 2).
2. Carefully measure the floor-to-floor height and determine the required number of spacers (D03) (TAB.2).
3. Assemble the spacers (D14, D03, D02) together in one piece. Do the same for the spacers (D04, D03, D02) (fig. 1).
4. Assemble the parts C63, C65, C66 into the baluster (C03) (fig. 3).
5. Assemble the parts B72, B73, B74, B78 into the landing E03, without tightening (fig. 7).
6. Assemble the base G03, B17 and B46 (fig. 1).

Assembly

7. Determine and mark on the floor the centre of the hole, then position the base (G03+B17+B46) (fig. 4).
8. Drill with 14 mm ($\frac{3}{8}$ ") drill bit and fix the base (G03+B17+B46) into the floor by means of the parts B13 (fig. 1).
9. Screw the pole (G02) into the base (G03+B17+B46) (fig. 1).
10. Insert the spacers (D14+D03+D02) (fig. 5).
11. Insert the base plate cover (D05 - D12) (fig. 5).
12. Insert the first tread (L02) into the pole (G02). Then continue with the assembly, by adding alternatively one spacer (D04+D03+D02) and one tread (L02). At this stage we suggest to position the treads alternately one to the right and one to the left, in order to distribute the weight in a balanced way (fig. 5).
13. When you reach the end of the pole (G02), screw the part B47 on it, then add the second pole (G02) and continue with the stair assembly (fig. 5).
14. When you reach the end of the pole (G02), screw on it the part B46 and the part G01. (Screw the part G01, until its upper end sticks out approximately 15 cm ($5\frac{29}{32}$ ") from the stair height (fig. 6). Continue adding the treads, by using the part D01 inserted into the spacers (D04+D03+D02).
15. Finally add the stair landing (E03). Fasten the parts B05, B04 and screw the part B03 sufficiently (fig. 1) but keeping in mind that the treads still have to be rotated to their final position and that the points A and B of the landing (E03) have touch the floor (fig. 8).

Fitting of the Landing

16. Screw the part B71 into the element B74, making it run till the end. Insert the parts B75, B76, B75 - in this order – and then again the element B71, without tightening too hard (fig. 7).
17. Approach the part B76 to the ceiling. Determine the position, then drill with 14 mm ($\frac{3}{8}$ ") drill bit and fix completely by using the part B58 (fig. 7).
18. Screw the lower part B71 till the points A, B and C touch the floor (fig. 8).
19. Block the upper part B71 on the part B76 (fig. 7).
20. Finally, block the part B73 (fig. 7).

Assembly of the Railing

21. Spread-out the treads (L02) fan-like, after having chosen the rotation direction. The stair is now ready to use.
22. Starting from the landing (E03), insert the longer railing balusters (C03 - H 1190 mm - $46\frac{7}{8}$ "), that build the connection between the treads. Face them with the part C63 showing the part with the holes turned upwards (fig. 10). Tighten only the part B02 of the lower tread (fig. 2).
23. Check very carefully the vertical position of the inserted balusters C03. This control is very important for insuring the best results.

24. Tighten the part B03 completely (fig. 10).
25. Tighten the part B02 of the upper tread completely (fig. 2).
26. Check once more the vertical position of the railing balusters (C03) and, if necessary, correct it, by repeating the previous operations.
27. Set the first baluster (C03 - H 1190 mm - 46 $\frac{7}{8}$ ") together with the reinforcing part (F07). Cut one long baluster (C03 - H 1190 mm - 46 $\frac{7}{8}$ ") to obtain the same size as all others you assembled previously.
28. Fix into the floor in relation to the first baluster (C03), the part F01, by drilling with 8 mm ($\frac{5}{16}$ ") diameter bit. Use the parts C58, B12 and B02 (fig. 1).
29. Find the handrail piece marked with letter "M" (A22) and the one with letter "R" (A23) which will be used for the railing of the landing (E03) (fig. 11).
30. Start to model the handrail pieces (A22) marked with "M", in order to give it the handrail staircase's shape most alike (fig. 1).
31. Beginning from the baluster (C03) on the landing (E03), start to fix the handrail (A22), that you have already slightly bent in the previous operation. Use the parts C64.
32. Connect all other handrail pieces (A22), by screwing, glueing and shaping them. Use the parts B33, D72 and the glue (X01).
33. When you reach the first baluster (C03) at the bottom of the stair, cut the excess piece of the handrail with a hacksaw.
34. Complete the handrail (A22) by assembling the part A37. Use the parts C64 and the glue (X01) (fig. 1).
35. Fit all remaining railing balusters into the treads (L02), tighten the part B02 and fix to the handrail (A22), paying attention to the vertical position (for the stairs with a diameter larger than 140 cm (55 $\frac{1}{2}$ "), we suggest that you first assemble the shorter balusters) (fig. 12).
36. Check again the regular shape of the handrail (A22) and, if necessary, correct it with a rubber hammer.
37. Complete the railing assembly by fitting the parts B82 into the lower part of the balusters (C03) (fig. 1).

Assembly of the Balustrade

38. Screw the baluster (C04) into the part G01 that sticks out from the landing (E03) (fig. 10).
39. Assemble the parts F01 into the holes of the landing (E03), using the parts B07, B06, B23 (fig. 1).
40. Position the shorter balusters (H. 935 mm - 36 $\frac{13}{16}$ ") and tighten the part B02 (fig. 1).
41. Fix the part A36 into the baluster (C04), by using the part B02 (fig. 1).
42. Fix the handrail (A23) marked with the letter "R", using the parts C64 (fig. 1).
43. In case there were walls around the stair and depending on their position, it could be necessary to set one or two more balusters (H. 935 mm - 36 $\frac{13}{16}$ ") (fig. 12).
44. In that case it is necessary to consider either the distance between all other balusters, or otherwise the distance from the wall. For the fixing it is suggested to drill the landing (E03) with 9 mm ($\frac{23}{64}$ ") diameter bit and to use the fixing parts F01, B02, B07, B06, B23. Whereas for the fixing into the floor it is suggested to drill with the 12 mm ($\frac{15}{32}$ ") drill bit and to use the parts F01, B02, B87 (fig. 13).

Final Assembly

45. In order to tighten the staircase at the intermediate points, you must fix into the wall the parts F09 and connect them to the balusters (C03) by using the part F08. Drill the wall with a drill bit 8 and use the parts C50, C49, C58, B12 (fig. 14).
46. Stick the panels (H01) to the treads (L02) using the part B96 (fig. 1).
47. Stick the panels (H03, H04), to the landing (E03) using the part B96 (fig. 1).

Français

ATTENTION : Effectuer l'installation dans les règles de l'art en utilisant des outils appropriés ; suivre scrupuleusement les instructions de montage. Pour réaliser un montage conforme aux normes en vigueur, il faut s'informer avant l'installation quant aux réglementations locales et nationales à respecter, en fonction du domaine d'utilisation (résidence privée principale, secondaire, bureaux, magasins,...).

Avant de commencer le montage, il faut débarrasser tous les éléments de l'escalier. Il faut les poser sur une grande surface et vérifier la quantité des éléments (TAB. 1 : A = Code, B = Quantité).

Montage préliminaire

1. Visser les éléments D32 et D33 dans les marches (L02) (fig. 2).
2. Mesurer attentivement la hauteur de sol à sol afin de déterminer la quantité des disques entretoises (D03) (TAB. 2).
3. Assembler les entretoises (D14, D03, D02) en une seule pièce. Assembler de la même manière les entretoises (D04, D03, D02) (fig. 1).
4. Assembler les éléments C63, C65, C66 à la colonnette (C03) (fig. 3).
5. Assembler les éléments B72, B73, B74, B78 au palier E03 sans serrer (fig. 7).
6. Assembler la base G03, B17 et B46 (fig. 1).

Assemblage

7. Déterminer le centre de la trémie sur le sol et positionner la base (G03+B17+B46) (fig. 4).
8. Percer avec la mèche de diamètre 14 mm ($35/64''$) et fixer la base (G03+B17+B46) au sol avec les éléments B13 (fig. 1).
9. Visser le pylône (G02) à la base (G03+B17+B46) (fig. 1).
10. Insérer les entretoises (D14+D03+D02) (fig. 5).
11. Insérer la couv- base (D05 - D12) (fig. 5).
12. Insérer la première marche (L02) dans le pylône (G02). Après, dans l'ordre et en continuant, insérer une entretoise (D04+D03+D02) et la marche suivante (L02). Positionner les marches, en alternant, à droite et à gauche de sorte que le poids soit distribué uniformément (fig. 5).
13. A la fin du pylône (G02), visser l'élément B47, visser le pylône (G02) suivant et continuer l'assemblage de l'escalier (fig. 5).
14. A la fin du pylône (G02), visser l'élément B46 et l'élément G01 (visser l'élément G01 en considérant qu'il doit dépasser la hauteur de l'escalier d'environ 15 cm ($5\ 29/32''$)) (fig. 6). Continuer à insérer les marches en employant l'élément D01 inséré dans l'entretoise (D04+D03+D02).
15. Insérer le palier (E03) à la fin. Insérer les éléments B05, B04 et serrer l'élément B03 suffisamment (fig. 1), en considérant que les marches doivent encore tourner et que les extrémités A et B du palier (E03) doivent toucher le sol (fig. 8).

Fixation du palier

16. Visser l'élément B71 sur l'élément B74 jusqu'au fond. Insérer, dans l'ordre, l'élément B75, B76, B75 et encore B71 sans trop serrer (fig. 7).
17. Approcher l'élément B76 au plancher. Déterminer la position, percer avec la mèche de diamètre 14 mm ($35/64''$) et fixer définitivement en employant l'élément B58 (fig. 7).
18. Visser l'élément inférieur B71 jusqu'à ce que les points A, B et C touchent le sol (fig. 8).
19. Bloquer l'élément supérieur B71 sur l'élément B76 (fig. 7).
20. Bloquer l'élément B73 en dernier (fig. 7).

Assemblage du garde-corps

21. Disposer les marches (L02) en éventail après avoir choisi le sens de rotation (fig. 9). Il est maintenant possible de monter sur l'escalier.
22. En commençant du palier (E03), insérer les colonnettes les plus longues (C03 - H 1190 mm - $46\ 7/8''$) qui unissent les marches (L02). Positionner les colonnettes (C03 - H 1190 mm - $46\ 7/8''$) avec l'élément C63 avec la

- partie percé vers le haut (fig. 10). Serrer seulement l'élément B02 de la marche inférieure (fig. 2).
23. Vérifier que les colonnettes (C03) soient montés sur une ligne verticale. Il faut faire attention parce que cette opération est très importante pour un bon résultat de montage.
 24. Serrer avec décision l'élément B03 (fig. 10).
 25. Serrer avec décision l'élément B02 de la marche supérieure (fig. 2).
 26. Contrôler de nouveau la ligne verticale des colonnettes (C03) et la corriger éventuellement en répétant les opérations précédentes.
 27. Positionner la première colonnette (C03 - H 1190 mm - 46 7/8") avec l'élément de renfort (F07). Egaliser la hauteur d'une colonnette longue (C03 - H 1190 mm - 46 7/8"), en coupant l'extrémité, à la hauteur des colonnettes qui viennent d'être montés (fig. 1).
 28. Fixer au sol, par rapport à la première colonnette (C03), l'élément F01, en perçant avec la mèche de diamètre 8 mm (5/16"). Employer les éléments C58, B12 et B02 (fig. 1).
 29. Repérer les pièces de main courante marqués par la lettre "M" (A22) et celle marqué par la lettre "R" (A23) qui sera utilisé sur le palier (E03) (fig. 11).
 30. Commencer à modeler les main courantes (A22) signés par la lettre "M" en essayant de leur donner une courbure qui suive le mieux celle de l'escalier (fig. 1).
 31. En commençant par la colonnette (C03) du palier (E03), commencer à fixer la main courante (A22), qui vient d'être modelé. Utiliser les éléments C64.
 32. Unir les autres pièces de main courantes (A22), en les vissant, les collant et les modelant de suite. Employer les éléments B33, D72 et la colle (X01).
 33. Par rapport à la première colonnette (C03) de l'escalier, couper la main courante de trop avec une scie à métaux.
 34. Compléter la main courante (A22) en fixant l'élément A37, en employant les éléments C64 et la colle (X01) (fig. 1).
 35. Insérer toutes les autres colonnettes dans les marches (L02), serrer l'élément B02 et les fixer à la main courante (A22) en faisant attention à leur ligne verticale (pour les modèles avec un diamètre plus grand que 140 cm (55 1/8"), nous conseillons d'assembler avant les colonnettes plus courtes) (fig. 12).
 36. Contrôler de nouveau la bonne ligne de la main courante (A22) et la corriger éventuellement en employant un marteau en gomme.
 37. Compléter l'assemblage du garde-corps, en insérant les éléments B82 dans la partie inférieure des colonnettes (C03) (fig. 1).

Assemblage de la balustrade

38. Visser la colonne (C04) sur l'élément G01 qui dépasse le palier (E03) (fig. 10).
39. Assembler les éléments F01, en employant les éléments B07, B06, B23 dans les trous passants qui se trouvent sur le palier (E03) (fig. 1).
40. Positionner les colonnettes plus courtes (H. 935 mm - 36 13/16") et serrer l'élément B02 (fig. 1).
41. Fixer l'élément A36 sur la colonne (C04) en employant l'élément B02 (fig. 1).
42. Fixer la main courante (A23) marqué par la lettre "R", en employant les éléments C64 (fig. 1).
43. Selon la position et l'existence de murs au tour de la trémie de l'escalier, il pourrait être nécessaire de poser une ou deux colonnettes (H. 935 mm - 36 13/16") de plus (fig. 12).
44. Dans ce cas, il est nécessaire de considérer la même distance qu'il y a entre les autres colonnettes ou vers le mur. Pour la fixation il est conseillé de percer le palier (E03) avec une mèche de diamètre 9 mm (23/64") et d'employer les éléments F01, B02, B07, B06, B23 tandis qu'il est conseillé de percer le sol avec une mèche de diamètre 12 mm (1/2") et d'employer les éléments F01, B02, B87 (fig. 13).

Assemblage final

45. Afin de rendre plus rigide l'escalier dans les points intermédiaires, il faut fixer au mur les éléments F09 et les unir, en employant les éléments F08, avec les colonnettes (C03). Percer avec la mèche de diamètre 8 mm (5/16") et employer les éléments C50, C49, C58, B12 (fig. 14).
46. Coller les revêtements (H01) sur les marches (L02), en employant l'élément B96 (fig. 1).
47. Coller les revêtements (H03, H04) sur le palier (E03), en employant l'élément B96 (fig. 1).

Español

CUIDADADO: realizar la instalación "según las reglas del arte", utilizando herramientas adecuadas; seguir estrictamente las instrucciones de montaje. Informarse antes de la instalación sobre los reglamentos locales y nacionales a respetar, en función del destino de uso (privado principal, secundario, oficinas, tiendas...).

Antes de empezar el ensamblado de la escalera, desembalar todas las piezas de la escalera. Colocarlas de manera que pueda verificarse las cantidades (TAB. 1: A = Código, B = Cantidad).

Montaje previo

1. Atornillar los elementos D32 y D33 a los peldaños (L02) (fig.2).
2. Medir cuidadosamente la altura de pavimento a pavimento para determinar la cantidad de discos distanciadores (D03) (TAB.2)
3. Montar entre sí los distanciadores (D14, D03, D02). Montar de la misma manera los distanciadores (D04, D03, D02).
4. Montar los elementos C63, C65, C66 al barrote (C03) (fig. 3).
5. Montar los elementos B72, B73, B74, B75 a la meseta E03 sin apretar (fig. 7).
6. Montar la placa base G03, B17 y B46 (fig. 1).

Ensamblaje

7. Hallar el centro del hueco sobre el pavimento y colocar la base (G03 + B17 + B46) (fig. 4).
8. Taladrar con una broca de diámetro 14 mm ($3\frac{3}{4}$ ") y fijar la base (G03 + B17 + B46) al pavimento con los elementos B13 (fig. 1).
9. Atornillar el tubo (G02) a la base (G03 + B17 + B46) (fig. 1).
10. Introducir los distanciadores (D14 + D03 + D02) (fig. 5).
11. Introducir el cubre placa (D05 - D12) (fig. 4).
12. Introducir el primer peldaño (L02) por el tubo (G02). Seguir introduciendo por orden un distanciador (D04 + D03 + D02) y el siguiente peldaño (L02) u así sucesivamente. Ir colocando los peldaños alternativamente a derecha e izquierda, para distribuir, así el peso uniformemente (fig. 5).
13. Alcanzado el extremo del tubo (G02) atornillar el elemento B47, atornillar el tubo (G02) siguiente y seguir ensamblando la escalera (fig. 5).
14. Alcanzado el extremo del tubo (G02), atornillar el elemento B46 y el elemento G01 (atornillar el elemento G01 teniendo en cuenta que debe sobrepasar la altura de la escalera de unos 15 cm ($5\frac{29}{32}$ "). Seguir introduciendo los peldaños utilizando el elemento D01 introducido en el distancial (D04 + D03 + D02).
15. Introducir la meseta (E03). Introducir los elementos B05, B04 y apretar el elemento B03 suficientemente, teniendo en cuenta que los peldaños deben poder moverse (fig. 1) y de manera que los puntos A y B de la meseta (E03) deben rozar el pavimento (fig. 8).

Fijación de la meseta

16. Enroscar entre sí los elementos B71 y B74 completamente. Introducir en orden los elementos B75, B76, B75 y B71 sin apretar excesivamente (fig. 7).
17. Presentar el elemento B76 al forjado. Determinar la posición correcta y taladrar con una broca de diámetro 14 mm ($3\frac{3}{4}$ ") y fijarlos con definitivamente el elemento B58 (fig. 7)
18. Atornillar el elemento inferior B71 hasta que los punto A, B y C lleguen a tocar el pavimento (fig. 8).
19. Bloquear el elemento superior B71 sobre el elemento (fig. 7).
20. Por ultimo fijar el elemento B73 (fig. 7).

Montaje de la barandilla

21. Abrir los peldaños (L02) en abanico, tras haber elegido el sentido de rotación (fig. 9). Ahora es posible subir por la escalera.
22. Empezar por la meseta (E03) adaptar el primer barrote largo (C03 - H 1190 mm - $46\frac{7}{8}$ ") de unión entre los peldaños (L02). Orientar los barrotes (C03 - H 1190 mm - $46\frac{7}{8}$ ") con el elemento C63 con la parte agujereada hacia arriba (fig. 10). Apretar solamente el elemento B02 del peldaño inferior (fig. 2)

23. Comprobar la verticalidad de todos los barrotes (C03) colocados. Tener mucho cuidado en este paso porque es muy importante para tener un buen resultado del montaje.
24. Apretar definitivamente el elemento B03 (fig. 10).
25. Apretar definitivamente los elementos B02 de los peldaños superiores (fig. 2).
26. Volver a controlar la verticalidad de los barrotes (C03) y corregirla, si fuera necesario, repitiendo las operaciones anteriores.
27. Colocar el primer barrote (C03 - H 1190 mm - 46 7/8") junto con el elemento de refuerzo (F07). Adaptar la altura de un barrote largo (C03 - H 1190 mm - 46 7/8"), cortando un extremo, a la altura de los barrotes recién ensamblados (fig. 1).
28. Fijar sobre el pavimento, coincidiendo con el primer barrote (C03), el elemento F01, taladrando con una broca de diámetro 8 mm (5/16"). Utilizar los elementos C58, B12 y B02 (fig. 1).
29. Separar los tramos de pasamanos, marcados con la letra "M" (A22) y el tramo marcado con la letra "R" (A23) que se utilizará en la meseta (E03) (fig. 11).
30. Modelar un tramo de pasamanos (A22), marcado con la letra "M" intentando darle la misma curvatura de la escalera (fig. 1).
31. Empezar por el barrote (C03) de la meseta (E03), iniciar a fijar el pasamanos (A22), ya doblado utilizando los elementos C64.
32. Unir los demás tramos de pasamanos (A22), roscandolos pegandolos y moldeandolos sucesivamente. Utilizar los elementos B33, D72 y el pegamento (X01).
33. A la altura del primer barrote (C03) de la escalera, cortar el pasamanos en exceso con una segueta metálica.
34. Completar el pasamanos (A22) fijando los elementos A37, utilizando el elemento C64 y el pegamento (X01) (fig. 1).
35. Montar los demás barrotes en los peldaños (L03), apretando el elemento B02 y fijar el pasamanos (A22) cuidando su verticalidad (para los modelos de diámetro superior a 140 cm (55 1/8"), aconsejamos montar antes los barrotes más cortos) (fig. 10).
36. Controlar la curvatura del pasamanos (A22) y posiblemente corregirla utilizando un martillo de goma.
37. Completar el montaje de la barandilla, introduciendo los elementos B82 de la parte inferior de los barrotes (C03) (fig. 1).

Montaje de la balaustrada

38. Atornillar la columna (C04) al elemento G01 que asoma de la meseta (E03) (fig. 8).
39. Colocar los elementos F01, utilizando los elementos B07, B06, B23 en los orificios existentes sobre la meseta (E03) (fig. 1).
40. Colocar los barrotes más cortos (H. 935 mm - 36 13/16") y apretar el elemento B02 (fig. 1).
41. Fijar el elemento A36 sobre la columna (C04) utilizando el elemento B02 (fig. 1).
42. Fijar el pasamanos (A23) marcado con la letra "R", utilizando los elementos C64 (fig. 1).
43. Según la posición y la presencia de paredes alrededor del hueco de la escalera podría ser necesario colocar uno o dos barrotes (H. 935 mm - 36 13/16") más (fig. 12).
44. En este caso es necesario considerar un espacio equidistante entre los demás barrotes y la pared. Para la fijación es recomendable taladrar la meseta (E03) con una broca de diámetro 9 mm (23/64") y utilizar los elementos F01, B02, B07, B08, B23 en cambio es recomendable taladrar el pavimento con una broca de diámetro 12 mm (13/32") y utilizar los elementos F01, B02, B87 (fig. 13).

Montaje final

45. Para darle mayor rigidez a la escalera en los puntos intermedios, fijar al muro los elementos F09 y unirlos, utilizando los elementos F08, con los barrotes (C03). Taladrar con una broca de diámetro 8 mm (5/16") y utilizar los elementos C50, C49, C58, B12 (fig. 14).
46. Pegar las huellas (H01 a los peldaños (L02), utilizando el elemento B96 (fig. 1).
47. Pegar las huellas (H03, H04) a la meseta (E03), utilizando el elemento B96 (fig. 1).

TAB 1

A	B		
	Ø 120 3' 11 1/4"	Ø 140 4' 7 1/8"	Ø 160 5' 3"
A22	5	5	5
A23	1	1	1
A36	2	2	2
A37	3	3	3
B02	48	61	62
B03	1	1	1
B04	1	1	1
B05	1	1	1
B06	7	8	9
B07	7	8	9
B12	7	7	10
B13	3	3	3
B17	1	1	1
B23	7	8	9
B33	6	6	6
B46	2	2	2
B47	1	1	1
B58	2	2	2
B71	4	4	4
B72	6	6	6
B73	2	2	2
B74	2	2	2
B75	4	4	4
B76	2	2	2
B78	2	2	2
B82	26	38	38
B87	2	2	2
B96	1	1	1
C03 1060 mm - 41 3/4"	1	13	13
C03 1095 mm - 43 1/8"	12	0	0
C03 1130 mm - 44 1/2"	0	12	12
C03 1190 mm - 46 7/8"	13	13	13
C03 935 mm - 36 13/16"	7	8	9
C04	1	1	1
C13	38	50	50
C36	1	1	1
C49	2	2	3
C50	2	2	3
C58	7	7	10
C63	33	46	47
C64	70	96	98
C65	33	46	47
C66	33	46	47
D01	4	4	4
D02	13	13	13
D03	65	65	65
D04	12	12	12
D05 - D12	1	1	1
D14	1	1	1
D32	38	50	50
D33	38	50	50
D72	6	6	6
E03	1	1	1
F01	8	9	10
F07	1	1	1
F08	2	2	3
F09	2	2	3
G01	1	1	1
G02	2	2	2
G03	1	1	1
H01	12	12	12
H03	1	1	1
H04	2	2	2
L02	12	12	12
X01	1	1	1

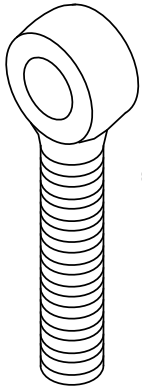

B74

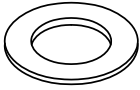

B75

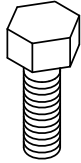

B07



B06



B23

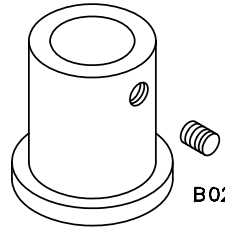

F01

B02

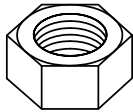

B71

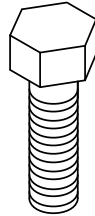

B73

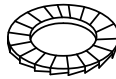

B72

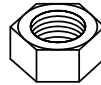

B78

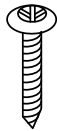

C64



B82



C13

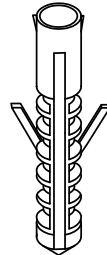

B12

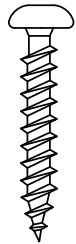

C58

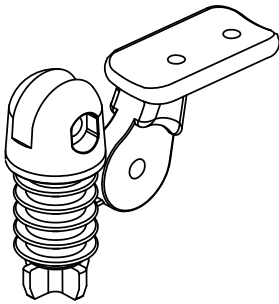

C63

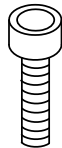

C50



C49

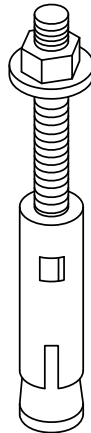

B87



C65



C66

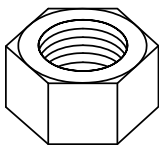

B03

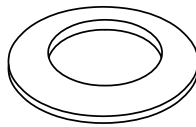

B04

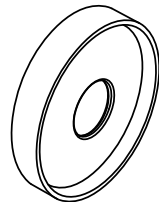

D72

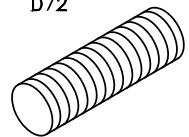

B33

English

To determine the necessary number of spacers (D03), you must look-up the table TAB.2 (H = Height, A = Rises).

Example: given a floor-to-floor height of 298cm (117 5/16") and a staircase with 13 treads, you must proceed as follows;

At height (298 cm (117 5/16") in the row H) look-up the number of necessary spacers (i.e. 50 spacers in the row A/13)

4. Distribute the spacers (D03), one at a time, among the combined parts D14-D04 and D02 all (for the single spacer D14 you can use at the most 3 spacers (D03); for the spacers (D04) you can use at the most 5 spacers (D03).

5. The final result is the following: 3 spacers (D03) between D14 and D02, 3 more spacers (D03) on a spacer chosen between D04 and D02 and 4 spacers (D03) between D04 and D02 of the remaining eleven spacers.

Français

Afin de déterminer la quantité nécessaire des entretoises (D03) en employant le TAB. 2 (H = hauteur totale, A = hauteurs).

Exemple : pour une hauteur sol à sol de 298 cm et un escalier avec 13 marches il faut ;

1. Par rapport à la hauteur (298 cm, dans la colonne H), lire la quantité des entretoises nécessaires (n° 50 bagues, dans la colonne A/13)
2. Distribuer les entretoises (D03), de suite, parmi les éléments D14-D04 et D02 une par fois, jusqu'à ce qu'elles finissent (sur l'unique entretoise D14 on peut insérer au maximum 3 bagues (D03); sur les entretoises D04 on peut insérer au maximum 5 bagues (D03).
3. Le résultat final est de 3 bagues (D03) parmi D14 et D02, encore 3 bagues (D03) sur une entretoise au choix parmi D04 et D02 et de 4 bagues (D03) parmi D04 et D02 sur les onze entretoises restantes.

Español

Para determinar la cantidad necesaria de discos distanciadores (D03) utilizar la TABLA 2 (H = altura, A = tabicas)

Ejemplo: para una altura de pavimento a pavimento de 298 cm y una escalera con 13 peldaños es necesario;

1. En la línea de la altura (298 cm, en la columna H), leer la cantidad de discos distanciadores necesarios (n° 50 discos, en la columna A/13).
2. Distribuir los discos distanciadores (D03), entre los elementos D14, D04 y D02 uno a la vez, hasta agotarlos (en el único distanciador D14 pueden introducir un máximo de 3 discos (D03); en los distanciadores D04 pueden introducirse un máximo de 5 discos (D03).
3. El resultado es de 3 discos (D03) entre D14 y D02, otros 3 discos (D03) en un distanciador cualquiera entre D04, D02 y 4 discos (D03) entre D04 y D02 en los once distanciadores que quedan.

TAB 2 - cm

H	A=10	A=11
	D03	D03
210	0	
211	2	
212	4	
213	6	
214	8	
215	10	
216	12	
217	14	
218	16	
219	18	
220	20	
221	22	
222	24	
223	26	
224	28	
225	30	
226	32	
227	34	
228	36	
229	38	
230	40	
231	42	0
232	44	2
233	46	4
234	48	6
235	50	8
236		10
237		12
238		14
239		16
240		18
241		20
242		22
243		24
244		26
245		28
246		30
247		32
248		34
249		36
250		38
251		40
252		42
253		44
254		46
255		48
256		50
257		52
258		54
259		56
260		58
261		60
262		62
263		64
264		
265		
266		
267		
268		
269		
270		
271		
272		
273		

H	A=12	A=13
	D03	KIT D03
252	0	
253	2	
254	4	
255	6	
256	8	
257	10	
258	12	
259	14	
260	16	
261	18	
262	20	
263	22	
264	24	
265	26	
266	28	
267	30	
268	32	
269	34	
270	36	
271	38	
272	40	
273	42	0
274	44	2
275	46	4
276	48	6
277	50	8
278	52	10
279	54	12
280	56	14
281	58	16
282	60	18
283	62	20
284	64	22
285	66	24
286	68	26
287	70	28
288	72	30
289	74	32
290	76	34
291	78	36
292	80	38
293	82	40
294	84	42
295	86	44
296	88	46
297	90	48
298	92	50
299	94	52
300	96	54
301	98	56
302	100	58
303	102	60
304	104	62
305	106	64
306	108	
307	110	
308	112	
309	114	
310	116	
311	118	
312	120	
313	122	
314	124	
315	126	

H	A=14	A=15
	D03	D03
294	0	
295	2	
296	4	
297	6	
298	8	
299	10	
300	12	
301	14	
302	16	
303	18	
304	20	
305	22	
306	24	
307	26	
308	28	
309	30	
310	32	
311	34	
312	36	
313	38	
314	40	
315	42	0
316	44	2
317	46	4
318	48	6
319	50	8
320	52	10
321	54	12
322	56	14
323	58	16
324	60	18
325	62	20
326	64	22
327	66	24
328	68	26
329	70	28
330	72	30
331	74	32
332	76	34
333	78	36
334	80	38
335	82	40
336	84	42
337	86	44
338	88	46
339	90	48
340	92	50
341	94	52
342	96	54
343	98	56
344	100	58
345	102	60
346	104	62
347	106	64
348	108	66
349	110	68
350	112	70
351	114	72
352	116	74
353	118	
354	120	
355	122	
356	124	
357	126	

H	A=16
	D03
336	0
337	2
338	4
339	6
340	8
341	10
342	12
343	14
344	16
345	18
346	20
347	22
348	24
349	26
350	28
351	30
352	32
353	34
354	36
355	38
356	40
357	42
358	44
359	46
360	48
361	50
362	52
363	54
364	56
365	58
366	60
367	62
368	64
369	66
370	68
371	70
372	72
373	74
374	76
375	78
376	80
377	
378	
379	
380	
381	
382	
383	
384	
385	
386	
387	
388	
389	
390	
391	
392	
393	
394	
395	
396	
397	
398	
399	

TAB 2 - in.

H	A=10	A=11
	D03	D03
6'	10 5/8"	0
6'	11 1/8"	2
6'	11 1/2"	4
6'	11 7/8"	6
7'	1 1/4"	8
7'	5/8"	10
7'	1"	12
7'	1 3/8"	14
7'	1 7/8"	16
7'	2 1/4"	18
7'	2 5/8"	20
7'	3"	22
7'	3 3/8"	24
7'	3 3/4"	26
7'	4 1/4"	28
7'	4 5/8"	30
7'	5"	32
7'	5 3/8"	34
7'	5 3/4"	36
7'	6 1/8"	38
7'	6 1/2"	40
7'	7"	42
7'	7 3/8"	44
7'	7 3/4"	46
7'	8 1/8"	48
7'	8 1/2"	50
7'	8 7/8"	10
7'	9 1/4"	12
7'	9 3/4"	14
7'	10 1/8"	16
7'	10 1/2"	18
7'	10 7/8"	20
7'	11 1/4"	22
7'	11 5/8"	24
8'	1/8"	26
8'	1/2"	28
8'	7/8"	30
8'	1 1/4"	32
8'	1 5/8"	34
8'	2"	36
8'	2 3/8"	38
8'	2 7/8"	40
8'	3 1/4"	42
8'	3 5/8"	44
8'	4"	46
8'	4 3/8"	48
8'	4 3/4"	50
8'	5 1/8"	52
8'	5 5/8"	54
8'	6"	
8'	6 3/8"	
8'	6 3/4"	
8'	7 1/8"	
8'	7 1/2"	
8'	8"	
8'	8 3/8"	
8'	8 3/4"	
8'	9 1/8"	
8'	9 1/2"	
8'	9 7/8"	
8'	10 1/4"	
8'	10 3/4"	
8'	11 1/8"	
8'	11 1/2"	

H	A=12	A=13
	D03	KIT D03
8'	3 1/4"	0
8'	3 5/8"	2
8'	4"	4
8'	4 3/8"	6
8'	4 3/4"	8
8'	5 1/8"	10
8'	5 5/8"	12
8'	6"	14
8'	6 3/8"	16
8'	6 3/4"	18
8'	7 1/8"	20
8'	7 1/2"	22
8'	8"	24
8'	8 3/8"	26
8'	8 3/4"	28
8'	9 1/8"	30
8'	9 1/2"	32
8'	9 7/8"	34
8'	10 1/4"	36
8'	10 3/4"	38
8'	11 1/8"	40
8'	11 1/2"	42
8'	11 7/8"	44
9'	1/4"	46
9'	5/8"	48
9'	1"	50
9'	1 1/2"	52
9'	1 7/8"	54
9'	2 1/4"	56
9'	2 5/8"	58
9'	3"	60
9'	3 3/8"	20
9'	3 7/8"	22
9'	4 1/4"	24
9'	4 5/8"	26
9'	5"	28
9'	5 3/8"	30
9'	5 3/4"	32
9'	6 1/8"	34
9'	6 5/8"	36
9'	7"	38
9'	7 3/8"	40
9'	7 3/4"	42
9'	8 1/8"	44
9'	8 1/2"	46
9'	8 7/8"	48
9'	9 3/8"	50
9'	9 3/4"	52
9'	10 1/8"	54
9'	10 1/2"	56
9'	10 7/8"	58
9'	11 1/4"	60
9'	11 3/4"	62
10'	1/8"	64
10'	1/2"	
10'	7/8"	
10'	1 1/4"	
10'	1 5/8"	
10'	2"	
10'	2 1/2"	
10'	2 7/8"	
10'	3 1/4"	
10'	3 5/8"	
10'	4"	

H	A=14	A=15
	D03	D03
9'	7 3/4"	0
9'	8 1/8"	2
9'	8 1/2"	4
9'	8 7/8"	6
9'	9 3/8"	8
9'	9 3/4"	10
9'	10 1/8"	12
9'	10 1/2"	14
9'	10 7/8"	16
9'	11 1/4"	18
9'	11 3/4"	20
10'	1/8"	22
10'	1/2"	24
10'	7/8"	26
10'	1 1/4"	28
10'	1 5/8"	30
10'	2"	32
10'	2 1/2"	34
10'	2 7/8"	36
10'	3 1/4"	38
10'	3 5/8"	40
10'	4"	42
10'	4 3/8"	44
10'	4 3/4"	46
10'	5 1/4"	48
10'	5 5/8"	50
10'	6"	52
10'	6 3/8"	54
10'	6 3/4"	56
10'	7 1/8"	58
10'	7 1/2"	60
10'	8"	62
10'	8 3/8"	64
10'	8 3/4"	66
10'	9 1/8"	68
10'	9 1/2"	70
10'	9 7/8"	30
10'	10 3/8"	32
10'	10 3/4"	34
10'	11 1/8"	36
10'	11 1/2"	38
10'	11 7/8"	40
11'	1/4"	42
11'	5/8"	44
11'	1 1/8"	46
11'	1 1/2"	48
11'	1 7/8"	50
11'	2 1/4"	52
11'	2 5/8"	54
11'	3"	56
11'	3 3/8"	58
11'	3 7/8"	60
11'	4 1/4"	62
11'	4 5/8"	64
11'	5"	66
11'	5 3/8"	68
11'	5 3/4"	70
11'	6 1/4"	72
11'	6 5/8"	74
11'	7"	
11'	7 3/8"	
11'	7 3/4"	
11'	8 1/8"	
11'	8 1/2"	

H	A=16	
	D03	
11'	1/4"	0
11'	5/8"	2
11'	1 1/8"	4
11'	1 1/2"	6
11'	1 7/8"	8
11'	2 1/4"	10
11'	2 5/8"	12
11'	3"	14
11'	3 3/8"	16
11'	3 7/8"	18
11'	4 1/4"	20
11'	4 5/8"	22
11'	5"	24
11'	5 3/8"	26
11'	5 3/4"	28
11'	6 1/4"	30
11'	6 5/8"	32
11'	7"	34
11'	7 3/8"	36
11'	7 3/4"	38
11'	8 1/8"	40
11'	8 1/2"	42
11'	9"	44
11'	9 3/8"	46
11'	9 3/4"	48
11'	10 1/8"	50
11'	10 1/2"	52
11'	10 7/8"	54
11'	11 1/4"	56
11'	11 3/4"	58
12'	1/8"	60
12'	1/2"	62
12'	7/8"	64
12'	1 1/4"	66
12'	1 5/8"	68
12'	2 1/8"	70
12'	2 1/2"	72
12'	2 7/8"	74
12'	3 1/4"	76
12'	3 5/8"	78
12'	4"	80
12'	4 3/8"	
12'	4 7/8"	
12'	5 1/4"	
12'	5 5/8"	
12'	6"	
12'	6 3/8"	
12'	6 3/4"	
12'	7 1/8"	
12'	7 5/8"	
12'	8"	
12'	8 3/8"	
12'	8 3/4"	
12'	9 1/8"	
12'	9 1/2"	
12'	10"	
12'	10 3/8"	
12'	10 3/4"	
12'	11 1/8"	
12'	11 1/2"	
12'	11 7/8"	
13'	1/4"	
13'	3/4"	
13'	1 1/8"	

FIG. 1

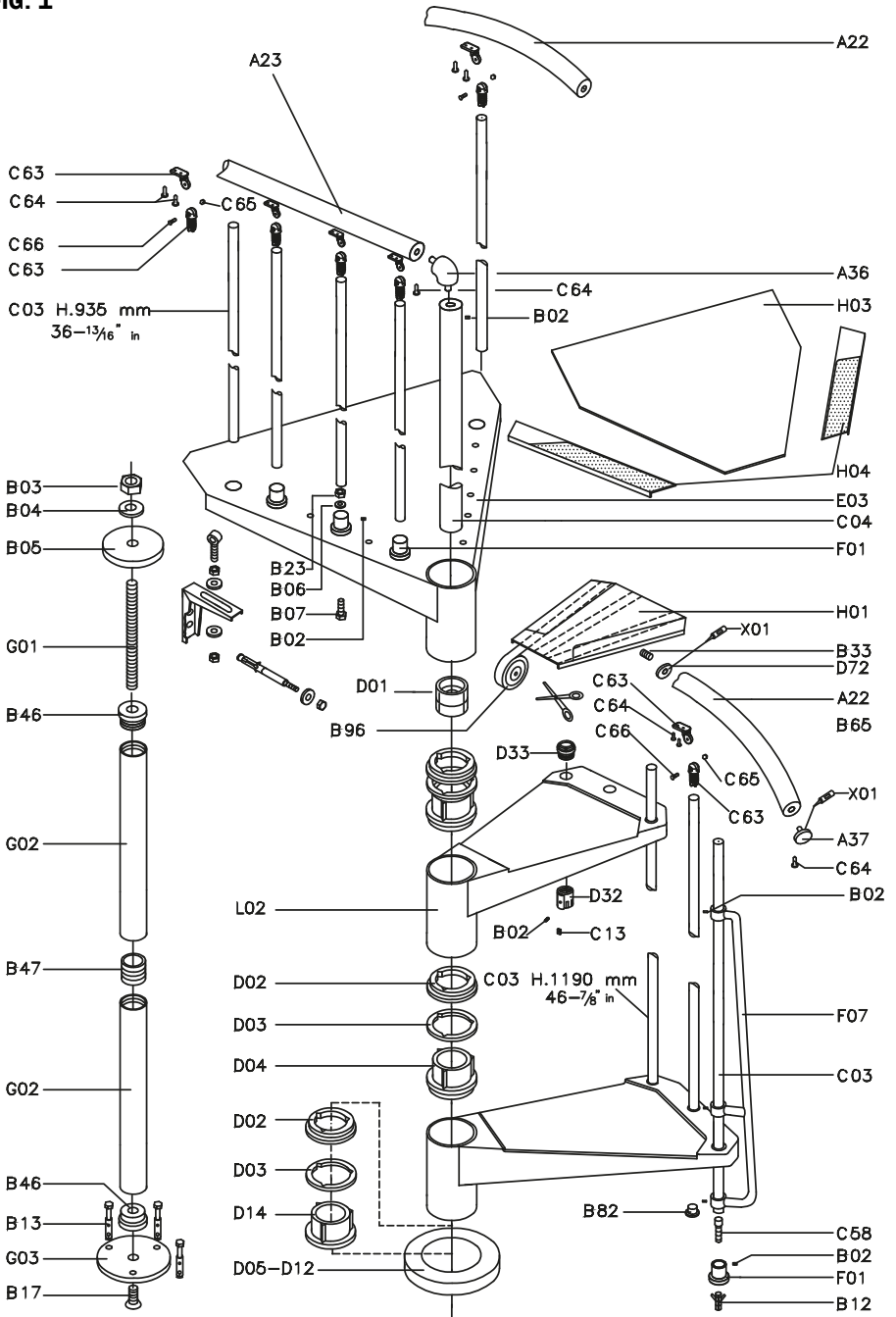

FIG. 2

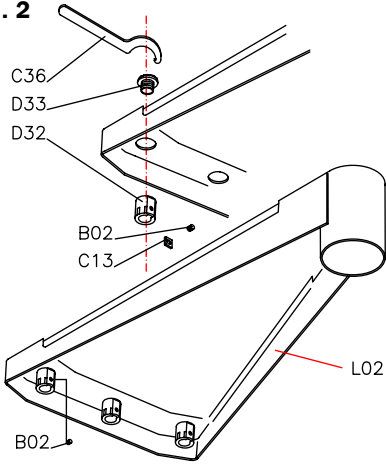

FIG. 3

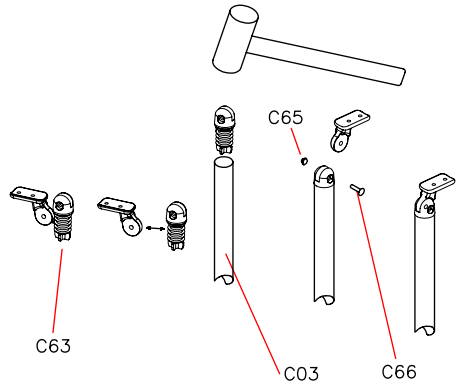

FIG. 4

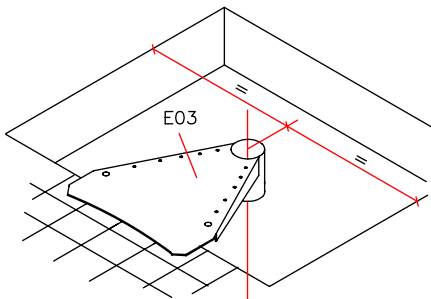

FIG. 5

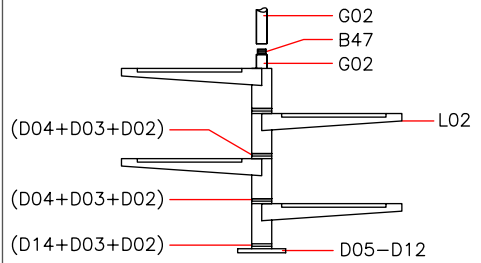

FIG. 6

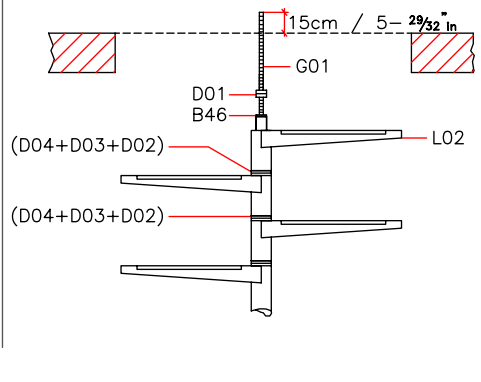

FIG. 7

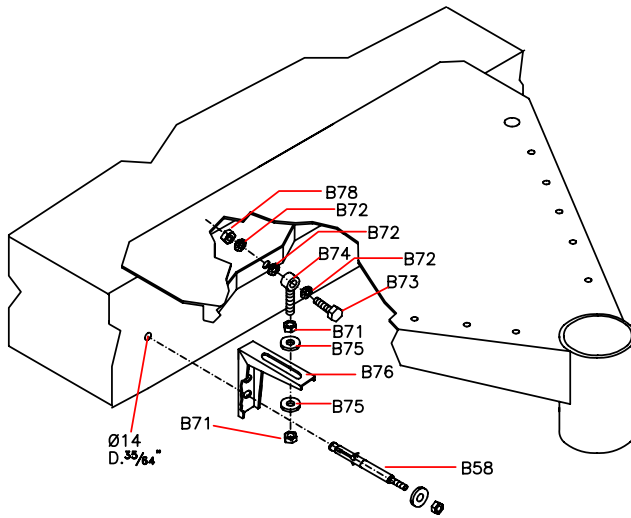

FIG. 8

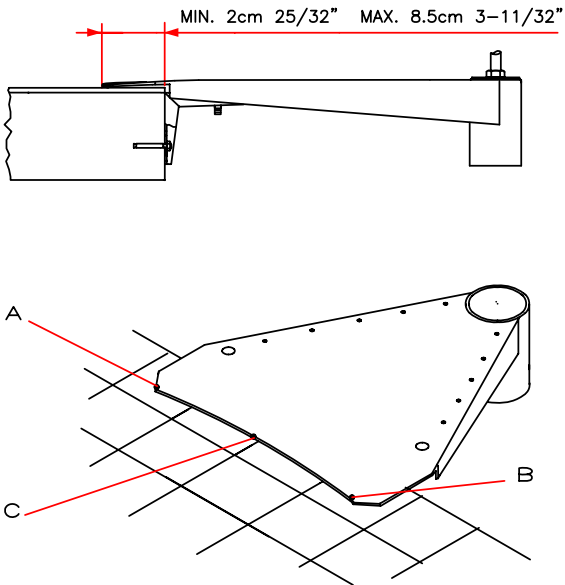
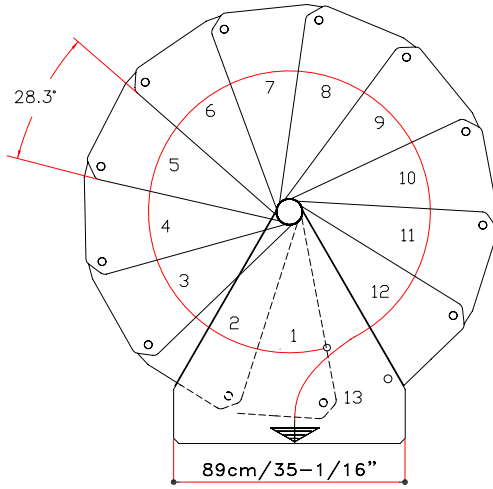
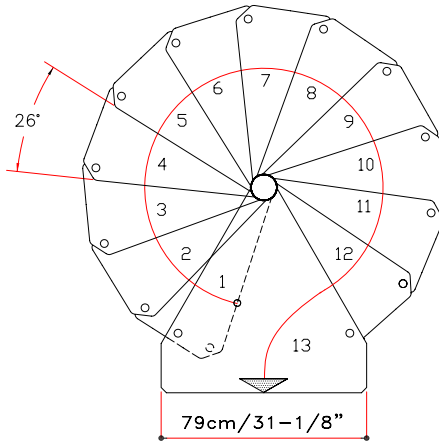
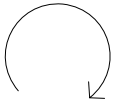

FIG. 9



$\text{Ø}160 \text{ cm}$
 $\text{D. } 63''$



$\text{Ø}140 \text{ cm}$
 $\text{D. } 55\frac{1}{8}''$

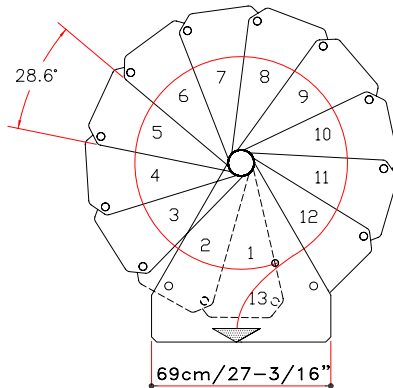

$\text{Ø}120 \text{ cm}$
 $\text{D. } 47\frac{1}{4}''$

FIG. 10

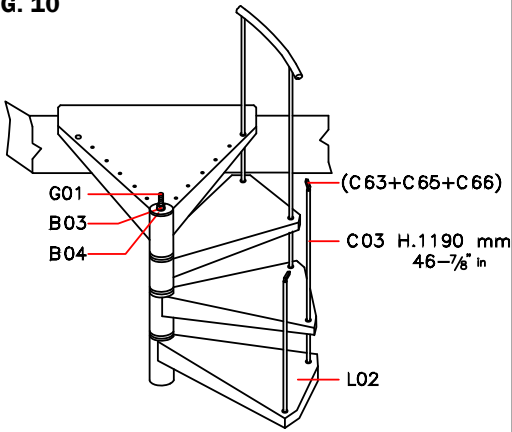

FIG. 11

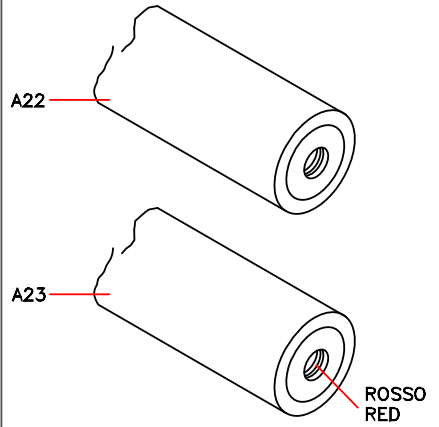

FIG. 12

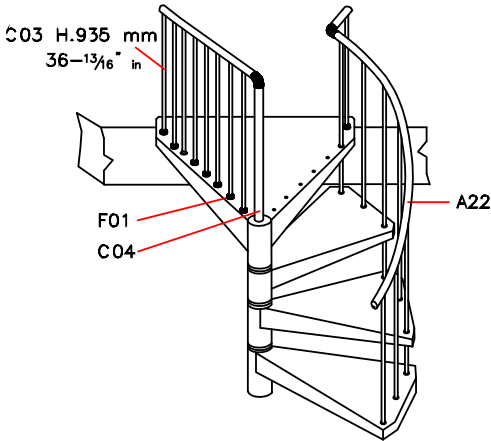

FIG. 13

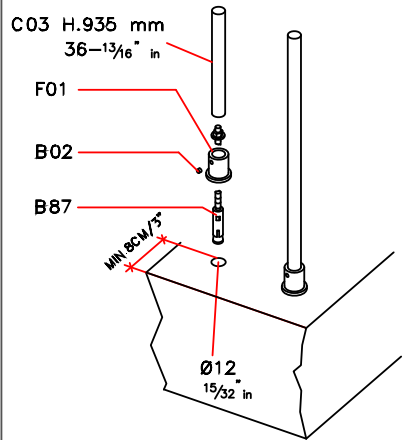
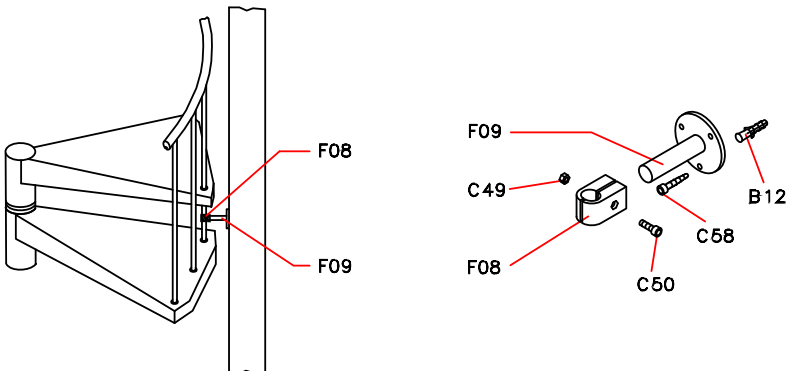
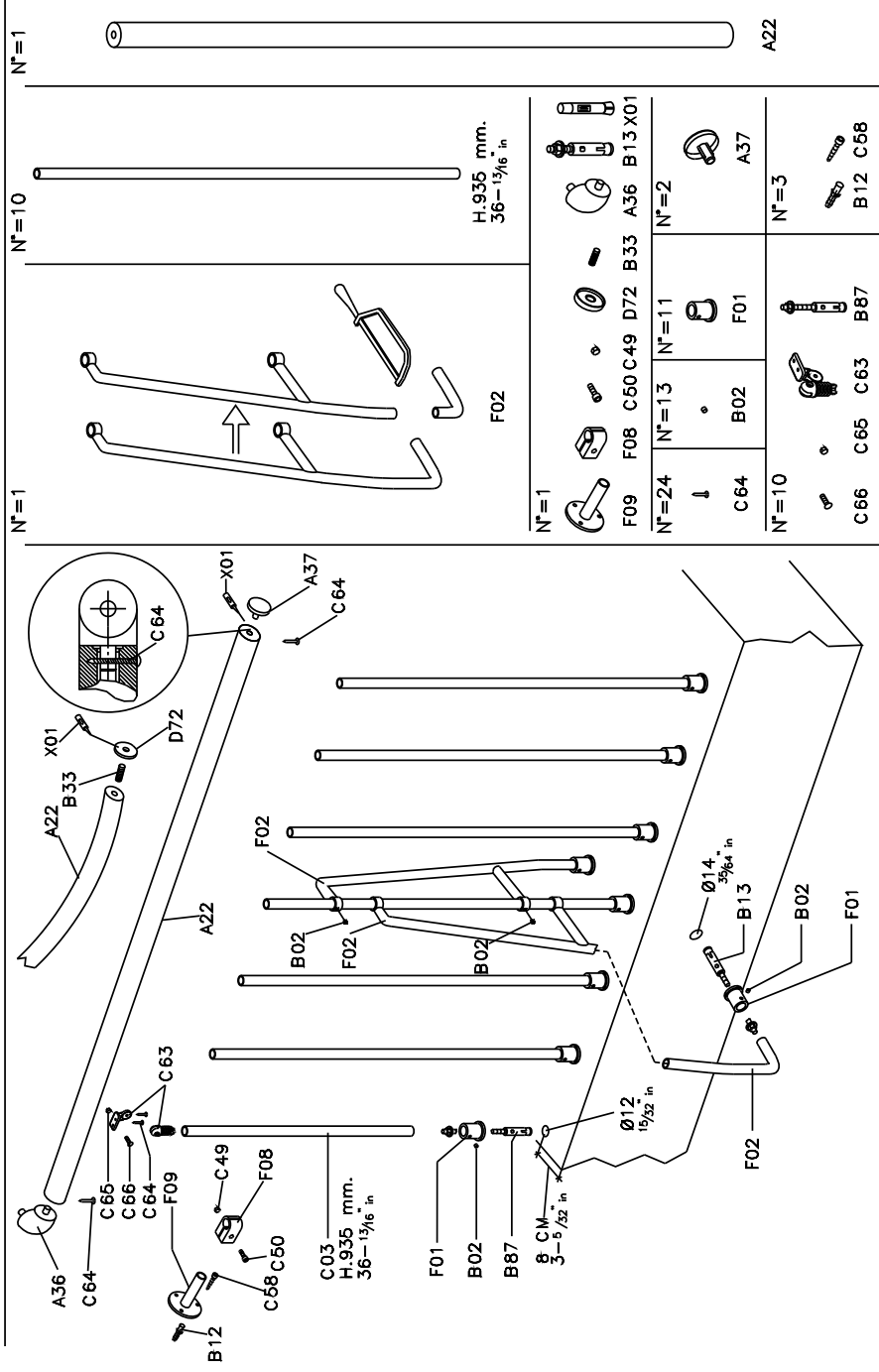

FIG. 14







English
Français
Español

PRODUCT DETAILS
DONNÉES D'IDENTIFICATION DU PRODUIT
DATOS DE IDENTIFICACIÓN

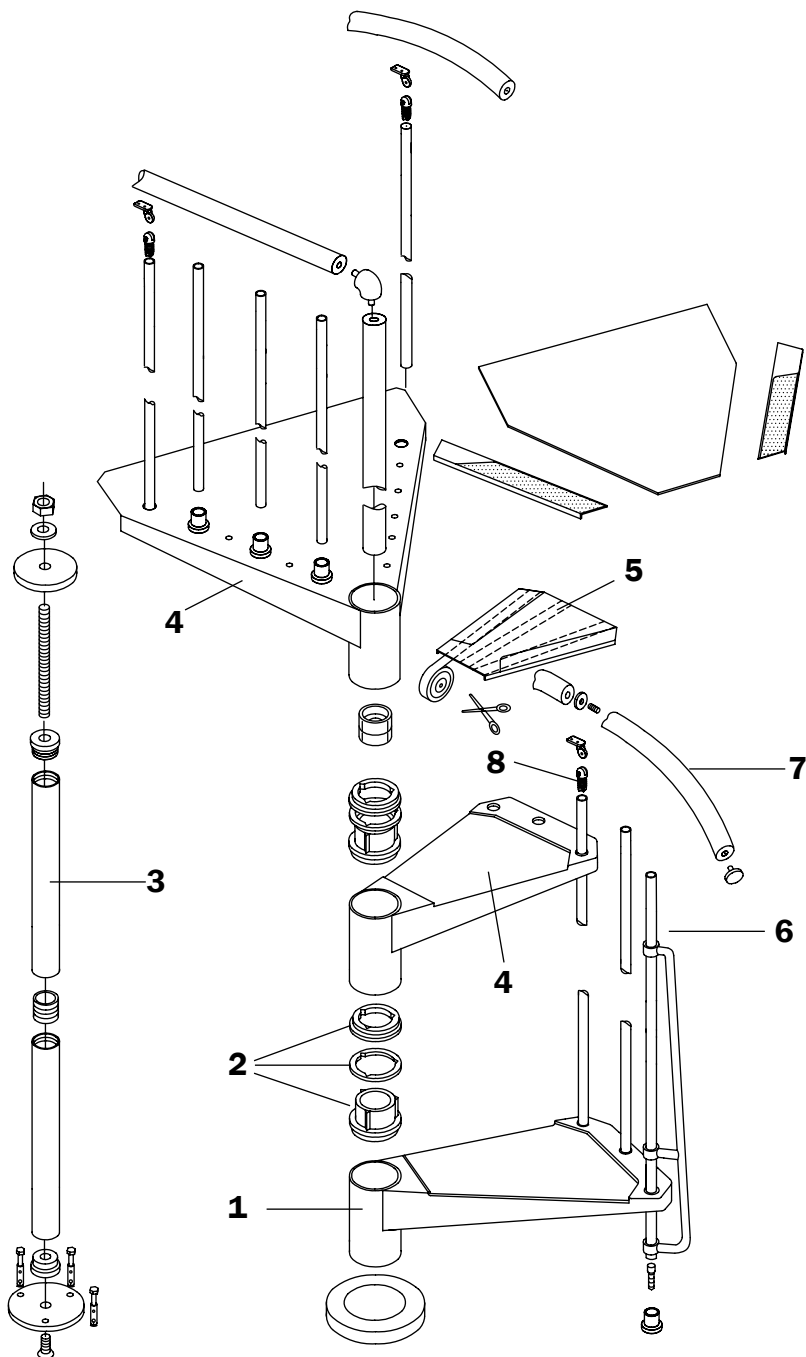

EN)

product details

trade name: **CK**

type: spiral round staircase

materials used

STRUCTURE

description

composed of spacers **(1)** in metal (welded to the tread) and spacers **(2)** in plastic stacked and packed on the central modular pole **(3)**

materials

spacers: Fe 370

plastic spacers: nylon

pole: Fe 370 galvanized

finishing

spacers: oven varnishing with epoxy powders

TREADS

description

treads **(4)** in metal circular or fan-shaped stacked on the central pole **(3)** equipped by an antiskid and antiwear panel **(5)**

materials

treads: plate Fe 370 thickness 25/10

antiskid panel: polypropylene

finishing

treads: oven varnishing with epoxy powders

RAILING

description

composed of vertical metal balusters **(6)** fixed to the treads **(4)** and by a PVC handrail **(7)**

materials

balusters: Fe 370

handrail: PVC with aluminium core

fixings **(8)**: nylon

finishing

balusters: oven varnishing with epoxy powders

OBLIGATORY CLEANING AND MAINTENANCE

Clean the treads as soon as dirt spots and dust deposits appear and at least every 6 months using a soft cloth moistened with water and specific non-abrasive and non-aggressive detergents. **NEVER** use abrasive scourers. After cleaning, thoroughly dry the surfaces with a microfibre cloth to remove the haloes that form because of the limestone in the water.

Approximately 12 months from the date of installation, check tightness of the screws of the various components. Should even the smallest malfunction occur, it is obligatory to immediately and professionally carry out extraordinary maintenance.

USE PRECAUTION

Avoid any improper use that is not in accordance with the product. possible violations or installations which don't comply with the providers instructions can invalidate the agreed product conformities.

FR)

données d'identification du produit

denomination commerciale : **CK**

typologie : escalier en colimaçon à plan rond

materiaux utilisés

STRUCTURE

description

composé de entretoises **(1)** en métal (soudées à la marche) et cales **(2)** en plastique empilées et comprimées sur le pylône **(3)** modulaire central

materiaux

entretoises : Fe 370

cales : nylon

pylône : Fe 370 galvanisé

finition

cales : vernissage à chaud avec poudres époxy

MARCHES

description

marches **(4)** en métal circulaires ou en éventail empilées sur le pylône **(3)** central équipées d'un panneau **(5)** antidérapant et antiusure

materiaux

marches : tôle Fe 370 épaisseur 25/10

panneau antidérapant : polypropylène

finition

marches : vernissage à chaud avec poudres époxy

GARDE-CORPS

description

composé de colonnettes **(6)** verticales en métal fixées aux marches **(4)** et d'une main courante **(7)** en PVC

materiaux

colonnettes : Fe 370

main courante : PVC avec noyau en aluminium

fixations **(8)** : nylon

finition

colonnettes : vernissage à chaud avec poudres époxy

NETTOYAGE ET MAINTENANCE OBLIGATOIRE

Nettoyer les marches dès que des taches de saleté ou des dépôts de poussière apparaissent ; effectuer également un nettoyage périodique, tous les 6 mois, à l'aide d'un chiffon doux, humecté d'eau et de détergents spécifiques non abrasifs et non agressifs. **NE JAMAIS** utiliser de la paille de fer abrasive. Après lavage, nettoyer et essuyer soigneusement avec un chiffon en microfibre, afin d'éliminer les auréoles provoquées par le calcaire contenu dans l'eau. Environ 12 mois après la date d'installation, contrôler le serrage des vis des différents composants. À la moindre défaillance, il est obligatoire d'effectuer immédiatement une maintenance corrective, dans les règles de l'art.

PRECAUTION D'UTILISATION

Eviter l'utilisation impropre et non conforme au produit. D'éventuelles alterations ou installations non correspondantes aux instructions du producteur peuvent invalider les conformités préétablies du produit.

PT)

dados de identificação do produto

denominação comercial: **CK**

tipo: escada em caracol de planta redonda

materiais empregados

ESTRUTURA

descrição

constituída por separadores **(1)** em metal (soldados no degrau) e anilhas distanciadoras **(2)** de plástico empilhados e comprimidos no poste **(3)** central modular

materiais

separadores: Fe 370

anilhas distanciadoras: matéria plástica nylon

poste: Fe 370 zincado

acabamento

separadores: pintura no forno com pós de epóxi

DEGRAUS

descrição

degraus **(4)** em metal circulares ou em leque, empilhados no pilar **(3)** central, equipados com painel **(5)** anti-derrapante e resistente ao desgaste

materiais

degraus: chapa Fe 370 anilha 25/10

painel anti-derrapante: polipropileno.

acabamento

degraus: pintura no forno com pós de epóxi

BALAUÍSTRE

descrição

constituída por colunas **(6)** verticais em metal fixas nos degraus **(4)** e por um corrimão **(7)** em PVC

materiais

hastes: Fe 370

corrimão: PVC com núcleo de alumínio

fixadores **(8)**: nylon

acabamento

colunas: pintura no forno com pós de epóxi

LIMPEZA E MANUTENÇÃO OBRIGATÓRIA

Efetuar a limpeza da escada assim que surgirem manchas de sujidade e depósitos de pó e periodicamente pelo menos a cada 6 meses com um pano macio humedecido em água e detergentes específicos não abrasivos e agressivos. **NUNCA** usar palha de aço ou esfregões abrasivos. Limpar e secar cuidadosamente após a lavagem com um pano em microfibra para eliminar os halos de calcário presentes na água. Depois de aproximadamente 12 meses após a data de instalação, verifique se os parafusos e as porcas das várias peças estão apertados. Em caso de qualquer mínima avaria, é obrigatório efetuar uma manutenção extraordinária, imediatamente e de acordo com as regras.

PRECAUÇÕES NO USO

Evite usos impróprios, não em conformidade, do produto. Quaisquer alterações e instalações não correspondentes às instruções do fabricante podem prejudicar as conformidades preestabelecidas para o produto.

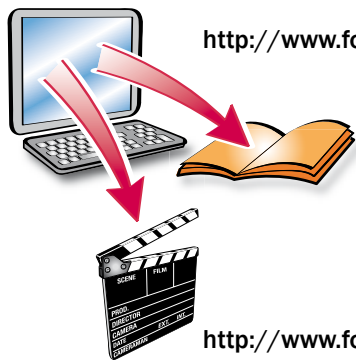

<http://www.fontanot.it/arke/>

<http://www.fontanot.it/video>



CK

D.U.M.
03/2019



Arkè by Fontanot S.p.A.
Via P. Paolo Pasolini, 6
47853 Cerasolo Ausa
Rimini, Italy

tel. +39.0541.90.61.11
fax +39.0541.90.61.24
info@fontanot.it
www.fontanot.it

cod. 065191000