



✉ 33 West Beaver Creek Road Richmond Hill
Ontario Canada L4B 1L8
☎ 800.660.5391
📠 800.660.5390
✉ info@eurofase.com
🌐 www.eurofase.com



IN-GROUND , 2-LIGHT IN-GROUND TWIN MR11

Product Specifications

Collection: Illuminations
Model No.: 19553
Height: 3.88"
Width: 3.13"
Length: 8"
Est. Shipping Weight: 2.566665 lbs
No. of Bulbs: 2
Bulb Wattage: 35 watts
Bulb Type: MR11/C
Bulb Base: GU4
Bulb Voltage: 12 volts

Options Available

ITEM CODE	FINISH	SHADE
19553-016	steel	n/a

Colour / Shades Available

FINISH	SHADE
steel	n/a

Rectangular MR11 dual up-light. 12V input, remote transformer required, sold separately. Tempered safety glass lens. Stainless steel outer trim. Cast aluminum metal body with powder coat finish. PVC mounting housing included.

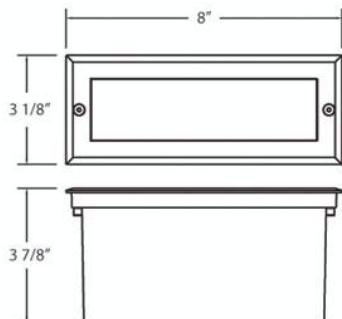

Project Information

Job Name: _____ Date: _____ Type: _____
Comments: _____