

22521-019



“VISIBLE AND GOOD LIGHT”.

- High corrosion resistance die-cast aluminum body
- Polyester painting with phosphocromating pre-finish
- Stainless steel ring AISI 304 - CD Range
- Stainless steel screws
- Electronic driver 120V 50/60Hz
- Silicone rubber gasket
- Max static weight resistance 5000kg
- Double M20 cable glands
- Polypropilene housing for recess included
- 3 feet of silicone wire included
- Ready to be installed



5 YEAR WARRANTY

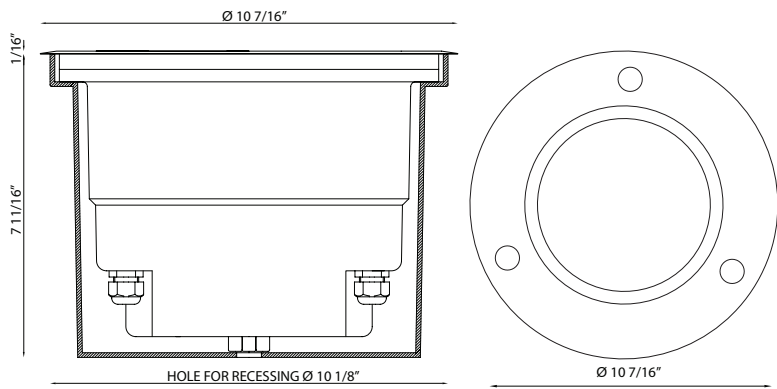

8 X 2 WATT CREE SUPER
 3000 KELVINS
 120 VOLTS LED DRIVER INCLUDED
 IP 67
 ADJUSTABLE ±15°



SPOT 10°

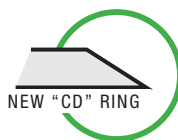

NEW "CD" RING

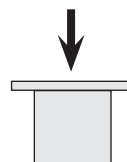

MAX 5.000 kg

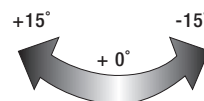

ADJUSTABLE

