

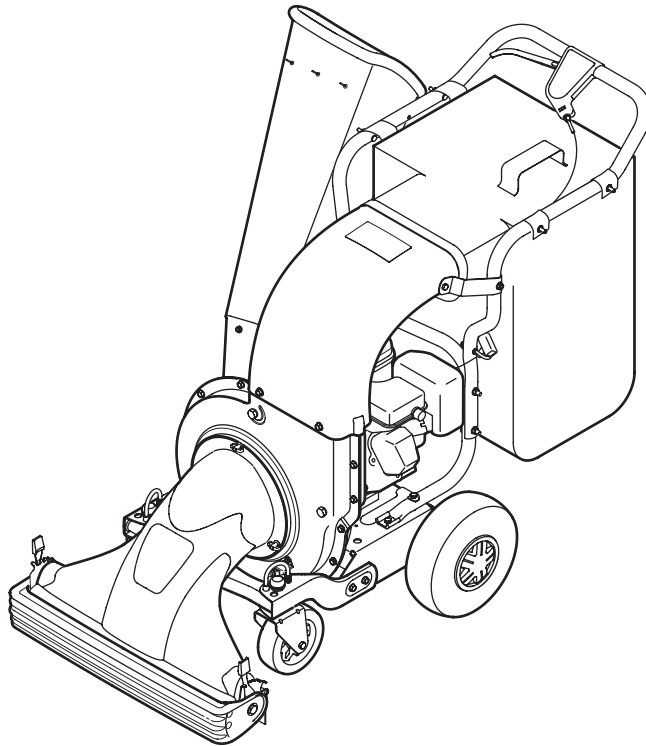

OPERATOR'S MANUAL



Chipper Shredder Vacuum Model CSV 206

WARNING

**READ AND FOLLOW ALL SAFETY RULES AND INSTRUCTIONS IN THIS MANUAL
BEFORE ATTEMPTING TO OPERATE THIS MACHINE.
FAILURE TO COMPLY WITH THESE INSTRUCTIONS MAY RESULT IN PERSONAL INJURY.**

TROY-BILT LLC, P.O. BOX 361131 CLEVELAND, OHIO 44136-0019

Thank You

Thank you for purchasing a Chipper/Shredder Vacuum manufactured by Troy-Bilt. It was carefully engineered to provide excellent performance when properly operated and maintained.

Please read this entire manual prior to operating the equipment. It instructs you how to safely and easily set up, operate and maintain your machine. Please be sure that you, and any other persons who will operate the machine, carefully follow the recommended safety practices at all times. Failure to do so could result in personal injury or property damage.

All information in this manual is relative to the most recent product information available at the time of printing. Review this manual frequently to familiarize yourself with the machine, its features and operation. Please be aware that this Operator's Manual may cover a range of product specifications for various models. Characteristics and features discussed and/or illustrated in this manual may not be applicable to all models. We reserve the right to change product specifications, designs and

equipment without notice and without incurring obligation.

If applicable, the power testing information used to establish the power rating of the engine equipped on this machine can be found at www.opei.org or the engine manufacturer's web site.

If you have any problems or questions concerning the machine, phone a authorized Troy-Bilt service dealer or contact us directly. Troy-Bilt's Customer Support telephone numbers, website address and mailing address can be found on this page. We want to ensure your complete satisfaction at all times.

Throughout this manual, all references to *right* and *left* side of the machine are observed from the operating position

The engine manufacturer is responsible for all engine-related issues with regards to performance, power-rating, specifications, warranty and service. Please refer to the engine manufacturer's Owner's/Operator's Manual, packed separately with your machine, for more information.

Table of Contents

<i>Safe Operation Practices</i>	3	<i>Maintenance & Adjustment</i>	12
<i>Assembly & Set-Up</i>	7	<i>Service</i>	14
<i>Controls & Features</i>	10	<i>Troubleshooting</i>	15
<i>Operation</i>	11	<i>Replacement Parts</i>	16

Record Product Information

Before setting up and operating your new equipment, please locate the model plate on the equipment and record the information in the provided area to the right. You can locate the model plate by standing at the operator's position and looking down at the rear of the frame. This information will be necessary, should you seek technical support via our web site, Customer Support Department, or with a local authorized service dealer.

MODEL NUMBER

--	--	--	--	--	--	--	--	--	--	--	--

SERIAL NUMBER

--	--	--	--	--	--	--	--	--	--	--	--

Customer Support

Please do NOT return the machine to the retailer or dealer without first contacting the Customer Support Department.

If you have difficulty assembling this product or have any questions regarding the controls, operation, or maintenance of this machine, you can seek help from the experts. Choose from the options below:

- ◇ Visit us on the web at www.troybilt.com



See How-to Maintenance and Parts Installation Videos at www.troybilt.com/tutorials

- ◇ Call a Customer Support Representative at (800) 828-5500 or (330) 558-7220
- ◇ Write to Troy-Bilt LLC • P.O. Box 361131 • Cleveland, OH • 44136-0019



WARNING: This symbol points out important safety instructions which, if not followed, could endanger the personal safety and/or property of yourself and others. Read and follow all instructions in this manual before attempting to operate this machine. Failure to comply with these instructions may result in personal injury.
When you see this symbol - **HEED ITS WARNING!**

CALIFORNIA PROPOSITION 65



WARNING: Engine Exhaust, some of its constituents, and certain vehicle components contain or emit chemicals known to State of California to cause cancer and birth defects or other reproductive harm.



DANGER: This machine was built to be operated according to the safe operation practices in this manual. As with any type of power equipment, carelessness or error on the part of the operator can result in serious injury. This machine is capable of amputating fingers, hands, toes and feet and throwing debris. Failure to observe the following safety instructions could result in serious injury or death.

Training

1. Read, understand, and follow all instructions on the machine and in the manual(s) before attempting to assemble and operate. Keep this manual in a safe place for future and regular reference and for ordering replacement parts.
2. Be familiar with all controls and their proper operation. Know how to stop the machine and disengage them quickly.
3. Never allow children under 16 years of age to operate this machine. Children 16 and over should read and understand the instructions and safe operation practices in this manual and on the machine and be trained and supervised by an adult.
4. Never allow adults to operate this machine without proper instruction.
5. Keep bystanders, pets, and children at least 75 feet from the machine while it is in operation. Stop machine if anyone enters the area.
6. Never run an engine indoors or in a poorly ventilated area. Engine exhaust contains carbon monoxide, an odorless and deadly gas.
7. Do not put hands and feet near rotating parts or in the feeding chambers and discharge opening. Contact with the rotating impeller can amputate fingers, hands, and feet.

8. Never attempt to unclog either the feed intake or discharge opening, remove or empty bag, or inspect and repair the machine while the engine is running. Shut the engine off and wait until all moving parts have come to a complete stop. Disconnect the spark plug wire and ground it against the engine.

Preparation

1. Thoroughly inspect the area where the equipment is to be used. Remove all rocks, bottles, cans, or other foreign objects which could be picked up or thrown and cause personal injury or damage to the machine.
2. Always wear safety glasses or safety goggles during operation and while performing an adjustment or repair, to protect your eyes. Thrown objects which ricochet can cause serious injury to the eyes.
3. Wear sturdy, rough-soled work shoes and close-fitting slacks and shirts. Loose fitting clothes or jewelry can be caught in movable parts. Never operate this machine in bare feet or sandals. Wear leather work gloves when feeding material in the chipper chute.
4. Before starting, check all bolts and screws for proper tightness to be sure the machine is in safe working condition. Also, visually inspect machine for any damage at frequent intervals.
5. Maintain or replace safety and instructions labels, as necessary.

Safe Handling of Gasoline:

To avoid personal injury or property damage use extreme care in handling gasoline. Gasoline is extremely flammable and the vapors are explosive. Serious personal injury can occur when gasoline is spilled on yourself or your clothes which can ignite. Wash your skin and change clothes immediately.

1. Use only an approved gasoline container.
2. Never fill containers inside a vehicle or on a truck or trailer bed with a plastic liner. Always place containers on the ground away from your vehicle before filling.
3. When practical, remove gas-powered equipment from the truck or trailer and refuel it on the ground. If this is not possible, then refuel such equipment on a trailer with a portable container, rather than from a gasoline dispenser nozzle.
4. Keep the nozzle in contact with the rim of the fuel tank or container opening at all times until fueling is complete. Do not use a nozzle lock-open device.
5. Extinguish all cigarettes, cigars, pipes and other sources of ignition.
6. Never fuel machine indoors.
7. Never remove gas cap or add fuel while the engine is hot or running. Allow engine to cool at least two minutes before refueling.
8. Never over fill fuel tank. Fill tank to no more than ½ inch below bottom of filler neck to allow space for fuel expansion.
9. Replace gasoline cap and tighten securely.
10. If gasoline is spilled, wipe it off the engine and equipment. Move unit to another area. Wait 5 minutes before starting the engine.
11. To reduce fire hazards, keep machine free of grass, leaves, or other debris build-up. Clean up oil or fuel spillage and remove any fuel soaked debris.
12. Never store the machine or fuel container inside where there is an open flame, spark or pilot light as on a water heater, space heater, furnace, clothes dryer or other gas appliances.

Operation

1. Do not put hands and feet near rotating parts or in the feeding chambers and discharge opening. Contact with the rotating impeller can amputate fingers, hands, and feet.
2. Before starting the machine, make sure the chipper chute, feed intake, and cutting chamber are empty and free of all debris.
3. Thoroughly inspect all material to be shredded and remove any metal, rocks, bottles, cans, or other foreign objects which could cause personal injury or damage to the machine.

4. If the impeller strikes a foreign object or if your machine should start making an unusual noise or vibration, immediately shut the engine off. Allow the impeller to come to a complete stop. Disconnect the spark plug wire, ground it against the engine and perform the following steps:
 - a. Inspect for damage.
 - b. Repair or replace any damaged parts.
 - c. Check for any loose parts and tighten to assure continued safe operation.
5. Do not allow an accumulation of processed material to build up in the discharge area. This can prevent proper discharge and result in kickback of material through the feed opening.
6. Do not attempt to shred or chip material larger than specified on the machine or in this manual. Personal injury or machine damage could result.
7. Never attempt to unclog either the feed intake or discharge opening while the engine is running. Shut the engine off, wait until all moving parts have stopped, disconnect the spark plug wire and ground it against the engine before clearing debris.
8. Never operate without vacuum bag and discharge chute properly attached to the machine. Never empty or change vacuum bag while the engine is running. Vacuum bag must be kept closed at all times during operation.
9. Never operate without either the inlet nozzle or optional hose attachment (if applicable) properly attached to the machine. Never attempt to attach or change either attachment while the engine is running.
10. Keep all guards, deflectors and safety devices in place and operating properly.
11. Keep your face and body back and to the side of the chipper chute while feeding material into the machine to avoid accidental kickback injuries.
12. Never operate this machine without good visibility or light. Always be sure of your footing and keep a firm hold on the handles.
13. Do not operate this machine on a paved, gravel or non-level surface.
14. Do not operate this machine while under the influence of alcohol or drugs.
15. Muffler and engine become hot and can cause a burn. Do not touch.
16. Never pick up or carry machine while the engine is running.
17. If situations occur which are not covered in this manual, use care and good judgement. Contact Customer Support for assistance and the name of the nearest service dealer.

Maintenance & Storage

1. Never tamper with safety devices. Check their proper operation regularly.
2. Check bolts and screws for proper tightness at frequent intervals to keep the machine in safe working condition. Also, visually inspect machine for any damage and repair, if needed.
3. Before cleaning, repairing, or inspecting, stop the engine and make certain the impeller and all moving parts have stopped. Disconnect the spark plug wire and ground it against the engine to prevent unintended starting.
4. Do not change the engine governor settings or overspeed the engine. The governor controls the maximum safe operating speed of the engine.
5. Maintain or replace safety and instruction labels, as necessary.
6. Follow this manual for safe loading, unloading, transporting, and storage of this machine.
7. Never store the machine or fuel container inside where there is an open flame, spark or pilot light such as a water heater, furnace, clothes dryer, etc.
8. Allow machine to cool at least 5 minutes before storing.
9. Always refer to the operator's manual for proper instructions on off-season storage.
10. If the fuel tank has to be drained, do this outdoors.
11. Observe proper disposal laws and regulations for gas, oil, etc. to protect the environment.
12. According to the Consumer Products Safety Commission (CPSC) and the U.S. Environmental Protection Agency (EPA), this product has an *Average Useful Life* of seven (7) years, or 60 hours of operation. At the end of the *Average Useful Life* have the machine inspected annually by an authorized service dealer to ensure that all mechanical and safety systems are working properly and not worn excessively. Failure to do so can result in accidents, injuries or death.

Do not modify engine

To avoid serious injury or death, do not modify engine in any way. Tampering with the governor setting can lead to a runaway engine and cause it to operate at unsafe speeds. Never tamper with factory setting of engine governor.

Notice Regarding Emissions

Engines which are certified to comply with California and federal EPA emission regulations for SORE (Small Off Road Equipment) are certified to operate on regular unleaded gasoline, and may include the following emission control systems: Engine Modification (EM), Oxidizing Catalyst (OC), Secondary Air Injection (SAI) and Three Way Catalyst (TWC) if so equipped.

Spark Arrestor









WARNING: This machine is equipped with an internal combustion engine and should not be used on or near any unimproved forest-covered, brushcovered or grass-covered land unless the engine's exhaust system is equipped with a spark arrestor meeting applicable local or state laws (if any).

If a spark arrestor is used, it should be maintained in effective working order by the operator. In the State of California the above is required by law (Section 4442 of the California Public Resources Code). Other states may have similar laws. Federal laws apply on federal lands.

A spark arrestor for the muffler is available through your nearest engine authorized service dealer or contact the service department, P.O. Box 361131 Cleveland, Ohio 44136-0019.

Safety Symbols

This page depicts and describes safety symbols that may appear on this product. Read, understand, and follow all instructions on the machine before attempting to assemble and operate.

Symbol	Description
	READ THE OPERATOR'S MANUAL(S) Read, understand, and follow all instructions in the manual(s) before attempting to assemble and operate
	WARNING— ROTATING BLADES Keep hands out of inlet and discharge openings while machine is running. There are rotating blades inside
	BYSTANDERS Keep bystanders, pets, and children at least 75 feet from the machine while it is in operation. Stop machine if anyone enters the area.
	WARNING— THROWN OBJECTS This machine may pick up and throw and objects which can ricochet.
	EYE PROTECTION Always wear safety glasses or safety goggles when operating this machine.
	WARNING— GASOLINE IS FLAMMABLE Allow the engine to cool at least two minutes before refueling.
	WARNING— CARBON MONOXIDE Never run an engine indoors or in a poorly ventilated area. Engine exhaust contains carbon monoxide, an odorless and deadly gas.



WARNING: Your Responsibility—Restrict the use of this power machine to persons who read, understand and follow the warnings and instructions in this manual and on the machine.

SAVE THESE INSTRUCTIONS!

Contents of Carton

- One Chipper Shredder Vacuum
- One Operator's Manual
- One Engine Operator's Manual
- One Chipper Chute
- One Nozzle
- One Safety Glasses
- One Bag
- One Tamper (If Equipped)
- One Bottle of Oil

Assembly

NOTE: This unit is shipped without gasoline or oil in the engine. Fill up gasoline and oil as instructed in the accompanying engine manual BEFORE operating your chipper shredder vacuum.

Nozzle

1. Remove three wing nuts from the front of the chipper shredder vacuum. See Figure 3-1.

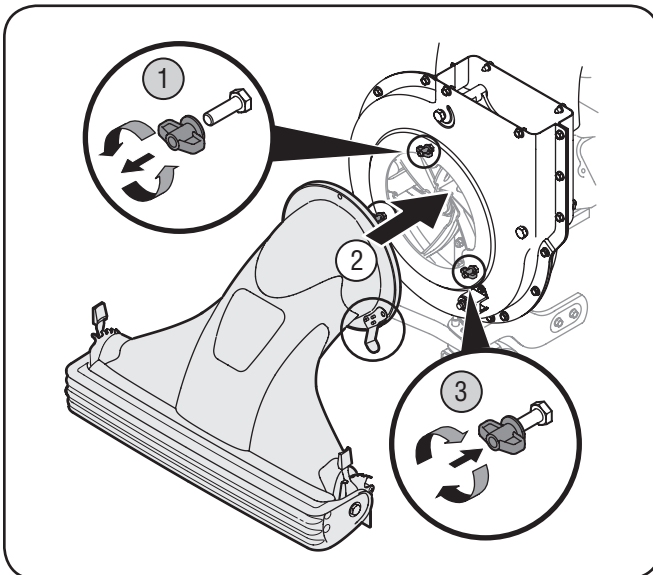

Figure 3-1

2. Place nozzle in position over three studs on unit.
3. Secure with wing nuts just removed. See Figure 3-1.

NOTE: The metal tab on the nozzle must depress the safety switch button attached to the front of the chipper shredder vacuum or engine will not start. See Figure 3-1.

Chipper Chute

1. Loosen, but do not remove, the two hex bolts, flat washers, and flange nuts which are secured to the support bracket. See Figure 3-2.

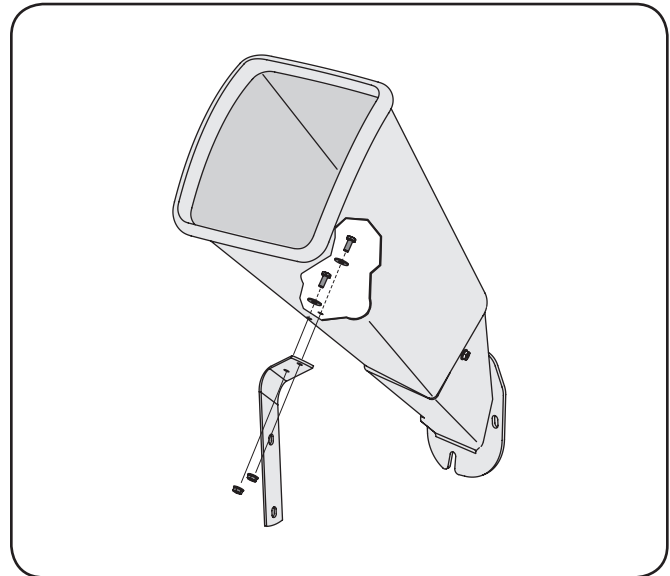

Figure 3-2

2. Remove the two flange nuts, hex bolts and saddle washers which secure the right side of the upper handle to the right side of the lower handle. See Figure 3-3A.

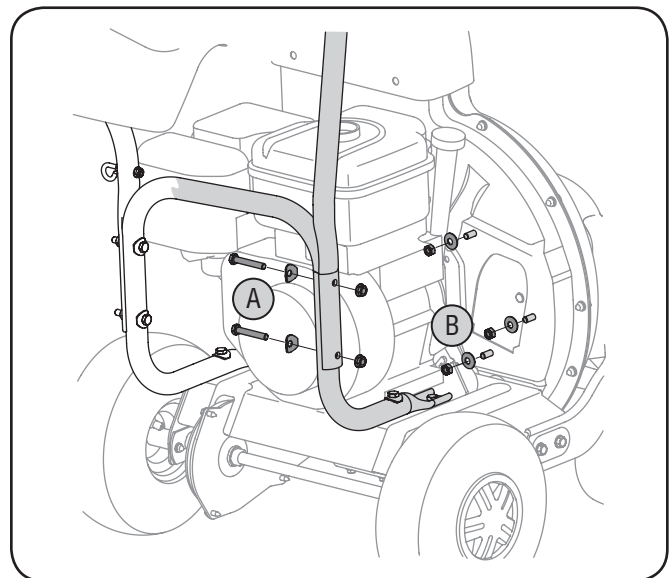

Figure 3-3

- Remove the three hex nuts and bell washers from the weld studs beside the opening on the right side of the chipper-shredder vacuum. See Figure 3-3B.
- Place the chipper chute over the weld studs keeping the slotted side towards the bottom. Loosely secure with the three hex nuts and bell washers that were removed earlier. Do not fully tighten the hex nuts at this point in the assembly. See Figure 3-4A.

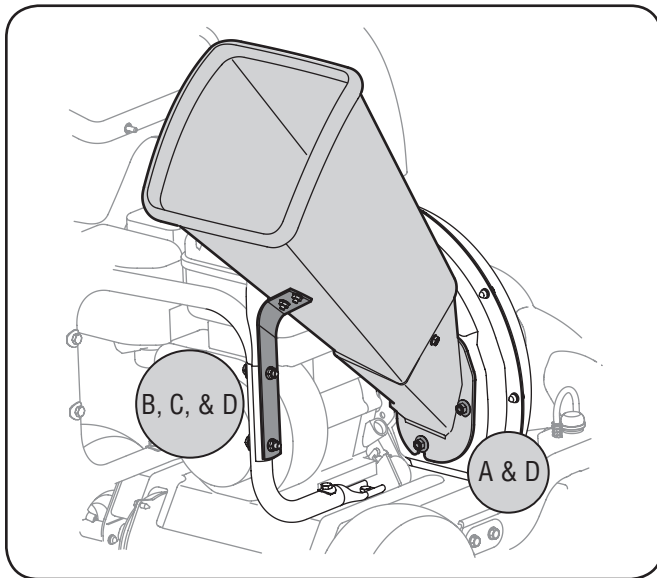

Figure 3-4

- Align the support bracket with the holes in the right side of the upper and lower handles where the hex bolts were just removed. See Figure 3-4B. Push up slightly on the chipper chute in order to better align the holes in the support bracket with the holes in the handles.
- Replace the hex bolts, saddle washers and flange nuts to affix the support bracket to the handle assemblies. See Figure 3-4C.
- Follow by tightening all hardware securely first on the chipper chute, then on the support bracket, and finally on the handle. See Figure 3-4D.

Bag

- Place bag under the upper handle assembly and slip the front opening on the bag over the discharge chute, making certain it is over the rim on the discharge chute. Follow direction of the arrows in Figure 3-5A.

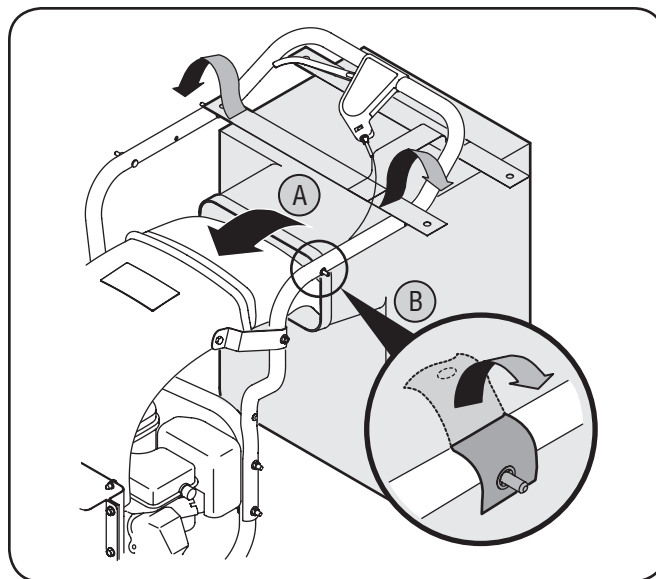

Figure 3-5

- Place the four straps on top of the bag over the upper handle, hooking them on the studs to secure in place. See Figure 3-5B.
- Squeeze the clamp on the drawstring and pull the drawstring tight. Release the clamp. See Figure 3-6.

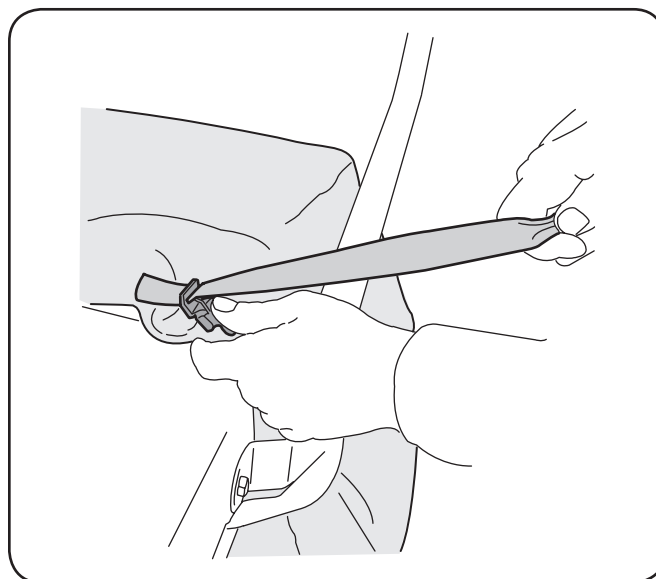

Figure 3-6

Adjustments

Nozzle Height

The nozzle adjustment levers are located on each side of the nozzle door. The nozzle door can be adjusted to one of five positions, ranging from 1/2" to 3" ground clearance, to provide best performance.

1. Push adjustment lever out away from nozzle.
2. Slide the height adjustment lever forward or backward for adjusting the nozzle door upwards or downwards. See Figure 3-7.

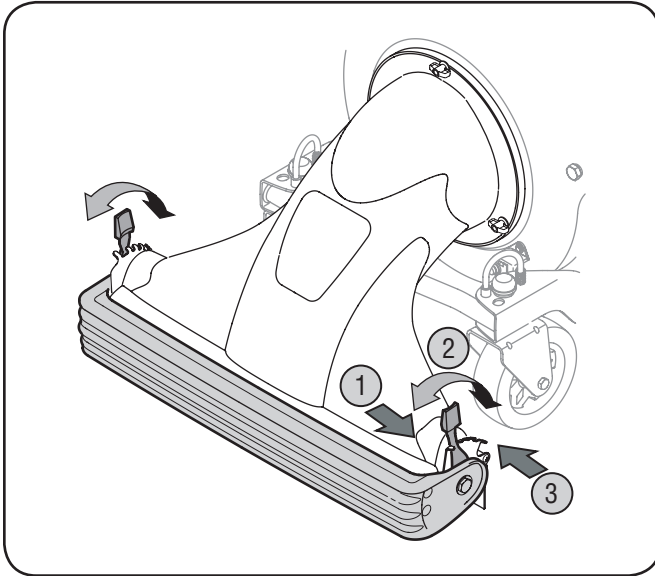

Figure 3-7

3. Release lever towards nozzle.

NOTE: Height must be adjusted equally. In general, raise the nozzle to vacuum a thick layer of leaves and lower the nozzle for smooth surfaces.

Front Caster Wheels

This chipper shredder vacuum is equipped with front caster wheels. The casters can be locked in a straight ahead position or to swivel freely.

1. Place pins in smaller holes to allow casters to rotate freely for maneuvering around trees and flower beds. See Figure 3-8.

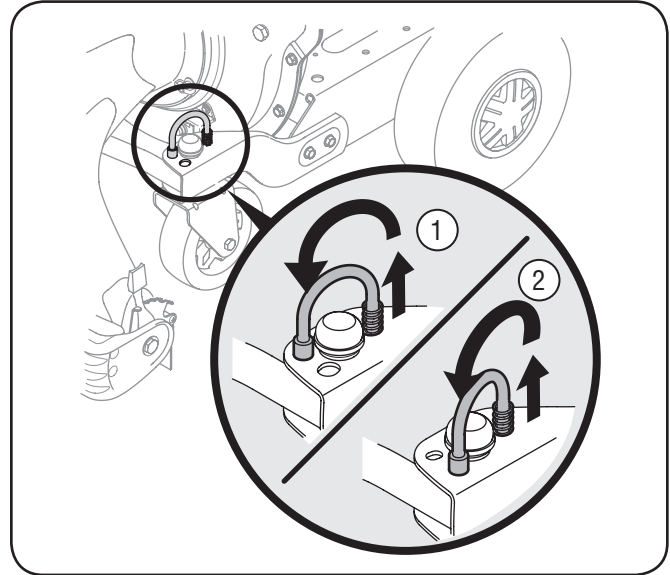

Figure 3-8

2. Lift and place pins in the larger holes for locked or straight ahead operation and when operating on slopes.

Set-Up

Gas and Oil Fill-Up

Refer to the separate engine owner's manual for additional engine information.

1. Add oil provided before starting unit for the first time out of the box.
2. Service the engine with gasoline as instructed in the separate engine owner's manual.



WARNING: Use extreme care when handling gasoline. Gasoline is extremely flammable and the vapors are explosive. Never fuel the machine indoors or while the engine is hot or running. Extinguish cigarettes, cigars, pipes and other sources of ignition.



WARNING: Never fill fuel tank indoors with engine running or until the engine has been allowed to cool for at least two minutes after running.

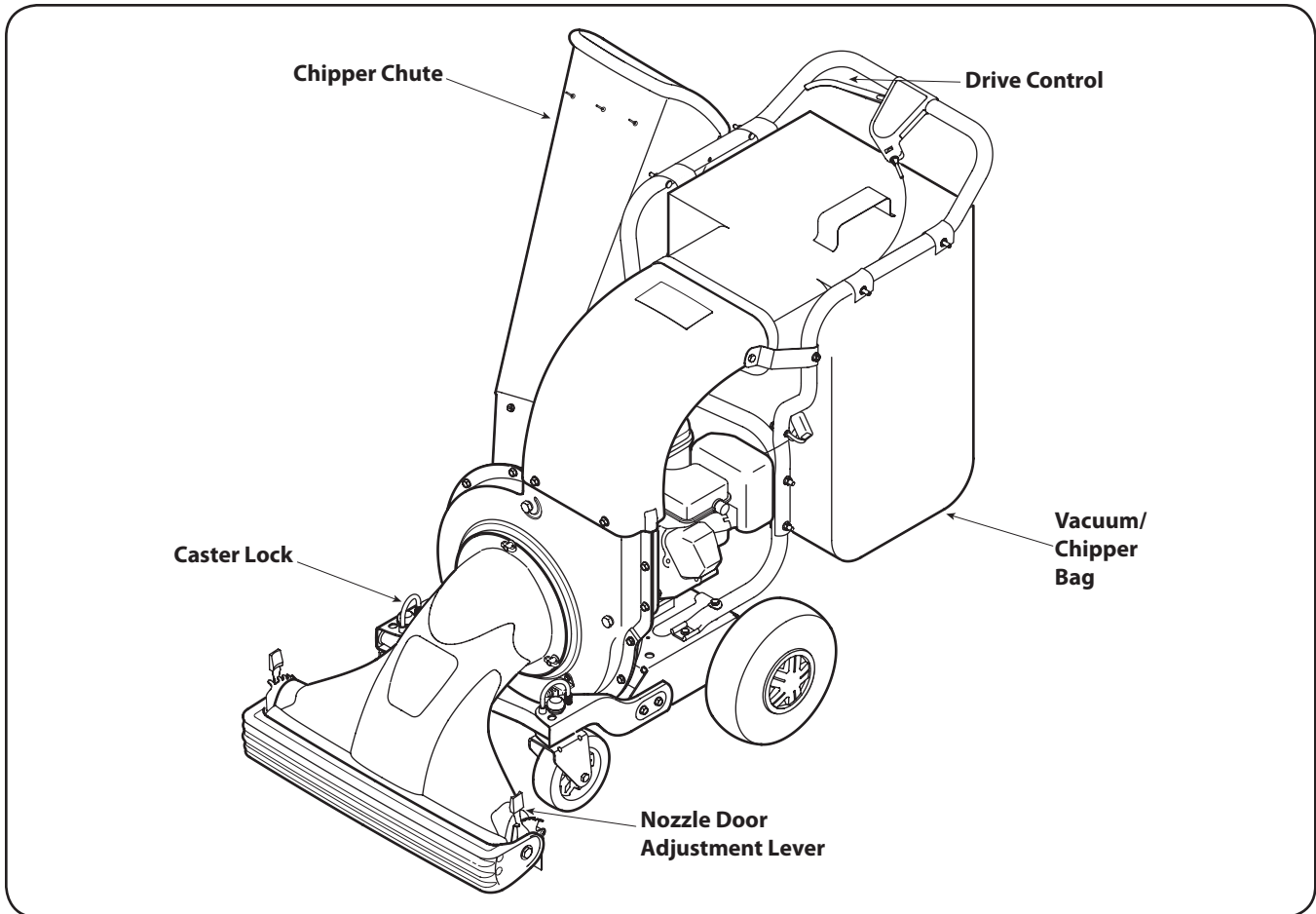

WARNING: Be familiar with all controls and their proper operation. Know how to stop the machine and disengage them quickly.

Drive Control

The drive control is located on the upper handle assembly. Squeezing the drive control against the upper handle engages the rear wheels. Release the drive control to slow down or stop wheel drive.

Chipper Chute

Allows twigs and small branches up to 3" in diameter to be fed into the impeller for chipping.

Nozzle Door Adjustment Levers

The nozzle adjustment levers are located on each side of the nozzle door. They are used to adjust nozzle door for ground clearance that will provide the best performance for the operating conditions.

Vacuum/Chipper Bag

Collects shredded or chipped material fed through the chipper chute or vacuumed up through the nozzle.

Caster Locks

The caster locks are located on top of each front caster wheel. Refer to the Assembly & Set-Up Section to position wheel locks.



WARNING: Always wear safety glasses during operation or while performing any adjustments or repairs. Thrown objects which ricochet can cause serious injury to the eyes.

Engine Controls

See the separate engine manual for the location and function of the controls on the engine.

Starting Engine



WARNING: Keep bystanders, helpers, pets, and children at least 75 feet from the machine before starting and while operating. Do not operate this machine unless the discharge chute and bag have been properly installed and secured to the machine.

1. Make certain drive control is in the disengaged (released) position.
2. Move choke lever on engine to CHOKE position. (A warm engine may not require choking).
3. Move engine throttle control lever to FAST or START position. See Figure 5-1.

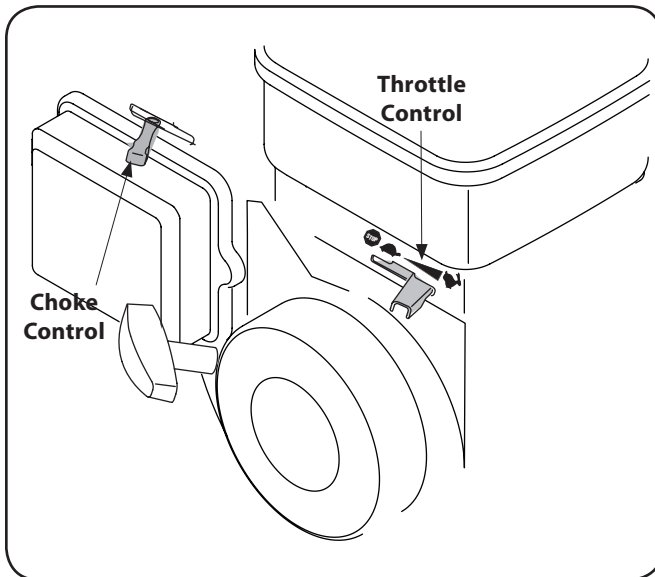

Figure 5-1

4. Place one foot on the left rear wheel to prevent the unit from skidding while starting.
5. Grasp starter handle and pull rope out slowly until engine reaches start of compression cycle (rope will pull slightly harder at this point).

NOTE: A noise will be heard at the start of the compression cycle, which will continue to be heard till the impeller reaches full speed.
6. Keeping a firm grip on the starter handle, pull rope with a rapid, continuous, full arm stroke. Let the rope rewind slowly.
7. Repeat the previous steps until engine fires. As the engine warms up, move choke control to RUN position.

NOTE: See your engine manual packed with your unit for more detailed instructions.

Stopping The Engine

1. Move throttle control lever to SLOW and then STOP or OFF position.

To Empty Bag

1. Open the large zipper in the rear of the bag to empty the contents. Be certain the zipper is closed completely when operating the unit.
2. If bag is removed for any reason, follow instructions for attaching the bag in the Assembly & Set-Up section.

To Engage Drive

- To engage the wheel drive, hold the drive control against the upper handle.
- Release the drive control to stop the rear wheels from driving.
- Release the drive control to slow down when negotiating an obstacle, making a turn, or stopping.
- Engage control slowly to prevent the front wheels from lifting up.

Using the Chipper Shredder Vacuum

- Place both hands on top of the upper handle and hold the drive control against the upper handle to propel the unit over yard. Yard waste such as leaves and pine needles can be vacuumed up through the nozzle for shredding.
- After material has been shredded by the blades on the impeller assembly, it will be discharged into catcher bag.
- Branches up to three inches in diameter can be fed into the chipper chute.

IMPORTANT: Do not attempt to shred or chip any material other than vegetation found in a normal yard (i.e. branches, leaves, twigs, etc.) Avoid fibrous plants such as tomato vines until they are thoroughly dried out. Materials such as stalks or heavy branches up to 3" in diameter may be fed into the chipper chute.



WARNING: Do not attempt to shred, chip, or vacuum any material larger than specified on the machine or in this manual. Personal injury or damage to the machine could result.

IMPORTANT: The flail screen is located inside the housing in the discharge area. If the flail screen becomes clogged, remove and clean as instructed in the Maintenance section. For best performance, it is also important to keep the chipper blade sharp.

Maintenance

General Recommendations

- Always observe safety rules when performing any maintenance.
- The warranty on this chipper/shredder vacuum does not cover items that have been subjected to operator abuse or negligence. To receive full value from warranty, operator must maintain the equipment as instructed here.
- Changing of engine-governed speed will void engine warranty.
- All adjustments should be checked at least once each season.
- Periodically check all fasteners and make sure these are tight.



WARNING: Always stop engine and disconnect spark plug wire before cleaning, lubricating or doing any kind of maintenance on your machine.

Lubrication

1. Lubricate the rear wheels with light oil once a season.
2. Lubricate each nozzle door adjustment lever once a season with light oil.
3. Grease fittings are located on the front caster wheels to provide easy lubrication of the swivel pins.

Equipment Care

- Clean the chipper/shredder vacuum thoroughly after each use.
- Wash bag periodically with water. Allow to dry thoroughly in shade.
- If the flail screen becomes clogged, remove and clean as instructed below.

NOTE: Cleaning with a forceful spray of water is not recommended as it could contaminate the fuel system.

Engine Care

- Refer to the separate engine manual for all engine maintenance instructions.
- Check engine oil level before each use as instructed in the separate engine manual packed with your unit. Read and follow instructions carefully.
- Clean air cleaner every 25 hours under normal conditions or once a season. Clean every few hours under extremely dusty conditions. To service the air cleaner, refer to the separate engine manual packed with your unit.
- The spark plug should be replaced once a season. Check engine manual for correct plug type and gap specifications.

Cleaning The Flail Screen

If the discharge area becomes clogged, remove the flail screen and clean area as follows:

1. Stop the engine. Make certain the chipper/shredder vacuum has come to a complete stop.
2. Disconnect spark plug wire from spark plug and ground against the engine.
3. Remove and set aside the vacuum bag.
4. Remove the four self-tapping screws from the bottom of the discharge chute. See Figure 6-1A.

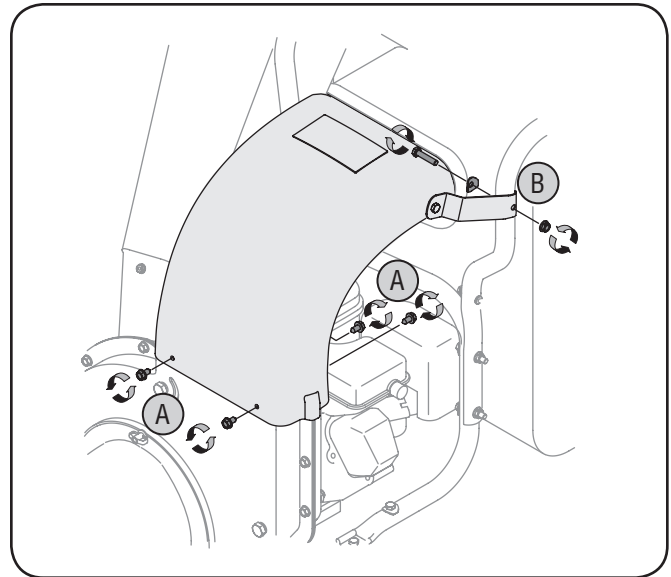

Figure 6-1

5. Remove the hex bolt, saddle washer and hex nut from the top and remove the discharge chute assembly. See Figure 6-2B.
6. Remove the two hex bolts and hex nuts which extend through the impeller housing. See Figure 6-2A.

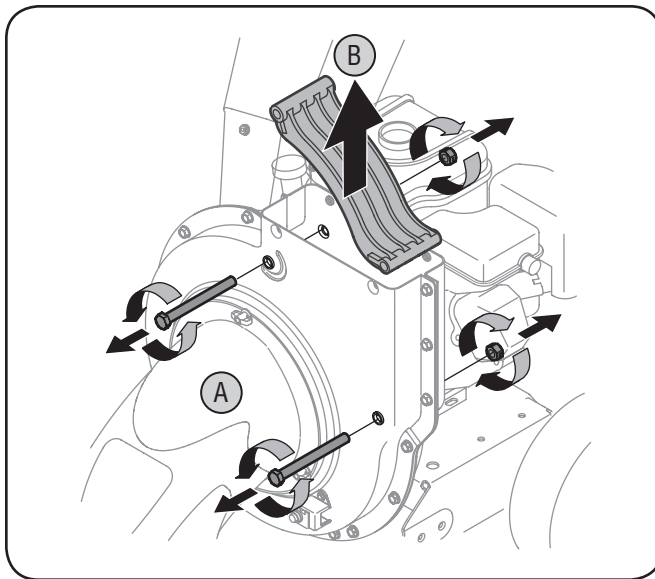

Figure 6-2

7. Lift the flail screen from inside the housing. See Figure 6-2B.
8. Clean the flail screen by scraping and/or washing with water, and reinstall the screen.
NOTE: Be certain to reassemble the flail screen with the curved side down.
9. Reattach the discharge chute assembly with the hardware previously removed and attach the bag to the unit.

Tire Pressure (Pneumatic tires only)

Maximum tire pressure under any circumstance is 30 psi. Equal tire pressure should be maintained at all times assembly.

Adjustments

Drive Control Cable

Periodic adjustment of the drive control cable may be required if:

- The chipper shredder vacuum moves forward with the drive control disengaged.
- It does not self-propel with the drive control engaged.
- Drive belt is slipping (unit hesitates while engine maintains the same speed).

Use the adjustment wheel located in the control housing to tighten or loosen the drive control cable until the above situation is corrected. See Figure 6-3.

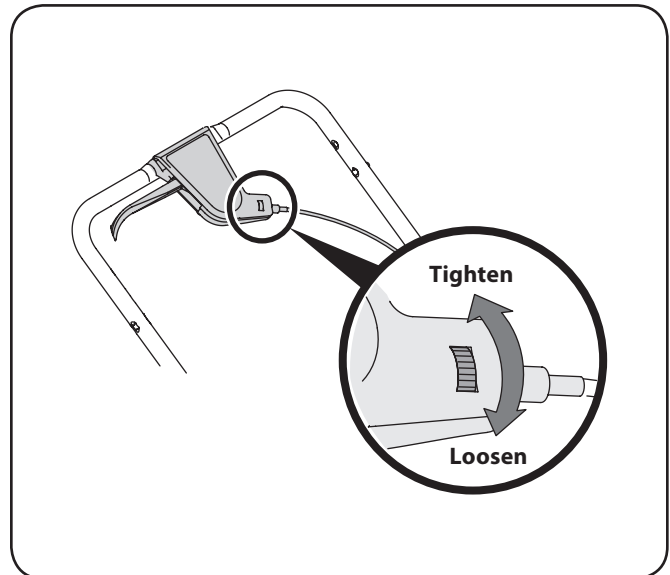

Figure 6-3

In addition, the adjustment wheel may also be used to determine the position in which the drive control is engaged. If it is more comfortable to have the drive engaged with the lever further away from the handle, tighten the cable.

Blade Care



WARNING: Before performing any type of maintenance on the machine, wait for all parts to stop moving and disconnect the spark plug wire. Failure to follow this instruction could result in personal injury or property damage.

NOTE: When tipping the unit, empty the fuel tank and keep engine spark plug side up.

1. Disconnect spark plug wire and ground it against engine.
2. Remove flail screen as instructed in previous section.
3. Remove plastic belt cover from front of the engine by removing the two self-tapping screws. See Figure 7-1A.

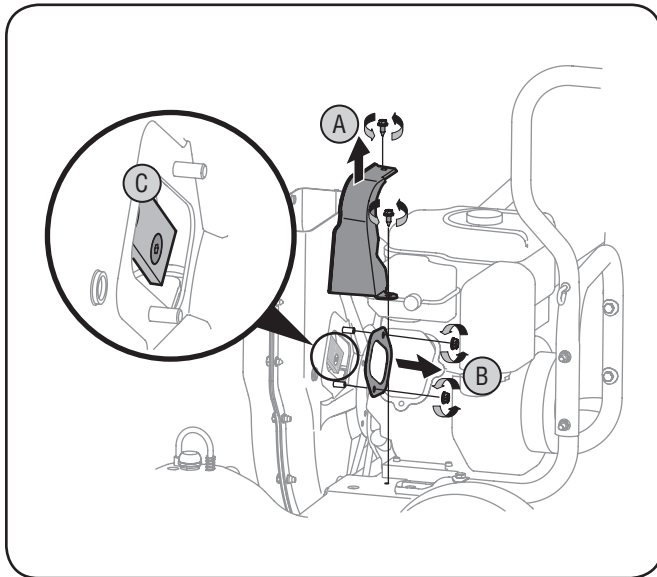

Figure 7-1

4. Remove the access plate by removing two hex lock nuts. See Figure 7-1B.
5. Locate one of the chipper blades in the access opening by rotating the impeller assembly by hand. Remove the chipper blade using a 3/16" allen wrench and a 1/2" wrench. See Figure 7-1C.

6. Remove other blade in the same manner to replace or sharpen.



WARNING: Use caution when replacing the blades. Wear heavy gloves to avoid injury while handling the weld bolts, housing or the blades.

NOTE: When sharpening blades, follow the original angle of grind. Also, make sure to remove an equal amount from each blade and torque hardware to 250 - 300 in.lb.

IMPORTANT: Make sure that blades are reassembled with the sharp edge facing upward.

Belt Care

NOTE: Several components must be removed and a special tool is required in order to change the chipper/shredder vacuum's belt. See an authorized Service Dealer to have your belt replaced.



Off-Season Storage

- When storing the chipper/shredder vacuum in an unventilated or metal storage shed, care should be taken to rustproof the non-painted surfaces. Using a light oil or silicone, coat the equipment, especially any springs, bearings, and cables.
- Remove all dirt from exterior of engine and equipment.
- Follow lubrication recommendations.
- Refer to engine manual for correct engine storage instructions.
- Store equipment in a clean, dry area. Do not store in an area where equipment is present that may use a pilot light or has a component that can create a spark.



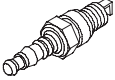
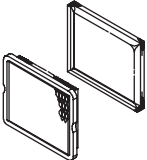

WARNING: Never store the machine or fuel container indoors where there is an open flame, spark, or pilot light such as on a water heater, furnace, clothes dryer, or other gas appliance.

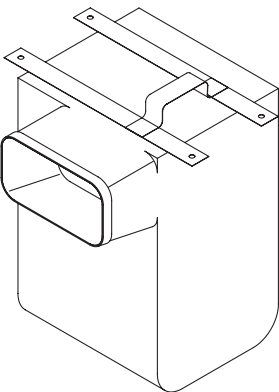
Problem	Cause	Remedy
Engine Fails to start	<ol style="list-style-type: none"> 1. Throttle lever not in correct starting position. 2. Spark plug wire disconnected. 3. Choke not in CHOKE position (if equipped). 4. Fuel tank empty or stale fuel. 5. Engine not primed (if equipped). 6. Faulty spark plug. 7. Engine flooded. 	<ol style="list-style-type: none"> 1. Move throttle lever to FAST or START position. 2. Connect wire to spark plug. 3. Move choke lever to CHOKE position. 4. Fill tank with clean, fresh gasoline. 5. Prime engine as instructed in Engine Manual. 6. Clean, adjust gap, or replace. 7. Wait a few minutes to restart, but do not prime.
Engine runs erratic	<ol style="list-style-type: none"> 1. Spark plug boot loose. 2. Unit running on CHOKE (if equipped). 3. Blocked fuel line or stale fuel. 4. Low engine RPM. 5. Water or dirt in fuel system. 6. Dirty air cleaner. 7. Carburetor out of adjustment. 	<ol style="list-style-type: none"> 1. Connect and tighten spark plug boot. 2. Move choke lever to OFF position. 3. Clean fuel line; fill tank with clean, fresh gasoline. 4. Always run engine at full throttle. 5. Drain fuel tank. Refill with fresh fuel. 6. Refer to engine manual. 7. See authorized service dealer.
Engine overheats	<ol style="list-style-type: none"> 1. Engine oil level low. 2. Dirty air cleaner. 	<ol style="list-style-type: none"> 1. Fill crankcase with proper oil. 2. Refer to engine manual.
Occasional skips (hesitates) at high speed	<ol style="list-style-type: none"> 1. Spark plug gap too close. 2. Carburetor idle mixture adjustment improperly set. 	<ol style="list-style-type: none"> 1. Remove spark plug and adjust gap to .030". 2. See authorized service dealer.
Excessive Vibration	<ol style="list-style-type: none"> 1. Loose parts or damaged impeller. 	<ol style="list-style-type: none"> 2. See authorized service dealer.
Unit does not discharge	<ol style="list-style-type: none"> 1. Discharge area clogged. 2. Foreign object lodged in impeller. 3. Low engine RPM. 4. Vacuum bag is full. 	<ol style="list-style-type: none"> 1. Stop engine immediately and disconnect spark plug wire. Clean flail screen and inside of discharge opening. 2. Stop engine and disconnect spark plug wire. Remove lodged object. 3. Always run engine at full throttle. 4. Empty bag.
Rate of discharge slows considerably or composition of discharged material changes	<ol style="list-style-type: none"> 1. Low engine RPM. 2. Chipper blade dull. 	<ol style="list-style-type: none"> 1. Always run engine at full throttle. 2. Replace chipper blade or see your authorized service dealer.
Unit fails to propel itself or slips when drive control is engaged	<ol style="list-style-type: none"> 1. Drive control cable out of adjustment. 2. Drive belt worn or damaged. 	<ol style="list-style-type: none"> 1. Follow adjustment procedure in Maintenance & Adjustments section of manual. 2. See authorized service dealer.

Component	Part Number and Description
	759-3336 Spark Plug
	BS-491588S Air Filter Cartridge BS-493537S Pre-Cleaner
	BS-799719 Fuel Cap
	BS-394358S † Fuel Filter
	964-04001 Bag

† If Equipped

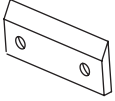
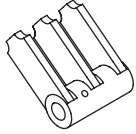
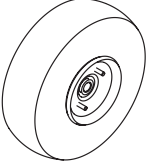
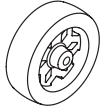
Phone (800) 828-5500 or (330) 558-7220 to order replacement parts or a complete Parts Manual (have your full model number and serial number ready). Parts Manual downloads are also available free of charge at www.troybilt.com.

Component	Part Number and Description
	942-0544B Chipper Blade (2 total)
	719-04308 Flail Blade (3 total)
	634-0244 Wheel (Rear)
	734-1804A Wheel (Front)
	954-0457 Belt

Phone (800) 828-5500 or (330) 558-7220 to order replacement parts or a complete Parts Manual (have your full model number and serial number ready). Parts Manual downloads are also available free of charge at www.troybilt.com.

MANUFACTURER'S LIMITED WARRANTY FOR



The limited warranty set forth below is given by Troy-Bilt LLC with respect to new merchandise purchased and used in the United States and/or its territories and possessions, and by MTD Products Limited with respect to new merchandise purchased and used in Canada and/or its territories and possessions (either entity respectively, "Troy-Bilt").

This warranty is in addition to any applicable emissions warranty provided with your product.

"Troy-Bilt" warrants this product (excluding its *Normal Wear Parts* and *Attachments* as described below) against defects in material and workmanship for a period of two (2) years commencing on the date of original purchase and will, at its option, repair or replace, free of charge, any part found to be defective in materials or workmanship. This limited warranty shall only apply if this product has been operated and maintained in accordance with the Operator's Manual furnished with the product, and has not been subject to misuse, abuse, commercial use, neglect, accident, improper maintenance, alteration, vandalism, theft, fire, water, or damage because of other peril or natural disaster. Damage resulting from the installation or use of any part, accessory or attachment not approved by Troy-Bilt for use with the product(s) covered by this manual will void your warranty as to any resulting damage.

Normal Wear Parts are warranted to be free from defects in material and workmanship for a period of thirty (30) days from the date of purchase. Normal wear parts include, but are not limited to items such as: batteries, belts, blades, blade adapters, tines, grass bags, wheels, rider deck wheels, seats, snow thrower skid shoes, friction wheels, shave plates, auger spiral rubber and tires.

Attachments — Troy-Bilt warrants attachments for this product against defects in material and workmanship for a period of one (1) year, commencing on the date of the attachment's original purchase or lease. Attachments include, but are not limited to items such as: grass collectors and mulch kits.

HOW TO OBTAIN SERVICE: Warranty service is available, WITH PROOF OF PURCHASE, through your local authorized service dealer. To locate the dealer in your area:

In the U.S.A.

Check your Yellow Pages, or contact Troy-Bilt LLC at P.O. Box 361131, Cleveland, Ohio 44136-0019, or call 1-866-840-6483, 1-330-558-7220 or log on to our Web site at www.troybilt.com.

In Canada

Contact MTD Products Limited, Kitchener, ON N2G 4J1, or call 1-800-668-1238 or log on to our Web site at www.mtdcanada.com.

This limited warranty does **not** provide coverage in the following cases:

- a. The engine or component parts thereof. These items may carry a separate manufacturer's warranty. Refer to applicable manufacturer's warranty for terms and conditions.
- b. Log splitter pumps, valves, and cylinders have a separate one-year warranty.

- c. Routine maintenance items such as lubricants, filters, blade sharpening, tune-ups, brake adjustments, clutch adjustments, deck adjustments, and normal deterioration of the exterior finish due to use or exposure.
- d. Service completed by someone other than an authorized service dealer.
- e. Troy-Bilt does not extend any warranty for products sold or exported outside of the United States and/or Canada, and their respective possessions and territories, except those sold through Troy-Bilt's authorized channels of export distribution.
- f. Replacement parts that are not genuine Troy-Bilt parts.
- g. Transportation charges and service calls.
- h. Troy-Bilt does not warrant this product for commercial use.

No implied warranty, including any implied warranty of merchantability or fitness for a particular purpose, applies after the applicable period of express written warranty above as to the parts as identified. No other express warranty, whether written or oral, except as mentioned above, given by any person or entity, including a dealer or retailer, with respect to any product, shall bind Troy-Bilt. During the period of the warranty, the exclusive remedy is repair or replacement of the product as set forth above.

The provisions as set forth in this warranty provide the sole and exclusive remedy arising from the sale. Troy-Bilt shall not be liable for incidental or consequential loss or damage including, without limitation, expenses incurred for substitute or replacement lawn care services or for rental expenses to temporarily replace a warranted product.

Some states do not allow the exclusion or limitation of incidental or consequential damages, or limitations on how long an implied warranty lasts, so the above exclusions or limitations may not apply to you.

In no event shall recovery of any kind be greater than the amount of the purchase price of the product sold. **Alteration of safety features of the product shall void this warranty.** You assume the risk and liability for loss, damage, or injury to you and your property and/or to others and their property arising out of the misuse or inability to use the product.

This limited warranty shall not extend to anyone other than the original purchaser or to the person for whom it was purchased as a gift.

HOW STATE LAW RELATES TO THIS WARRANTY: This limited warranty gives you specific legal rights, and you may also have other rights which vary from state to state.

IMPORTANT: Owner must present Original Proof of Purchase to obtain warranty coverage.

Troy-Bilt LLC, P.O. BOX 361131 CLEVELAND, OHIO 44136-0019; Phone: 1-866-840-6483, 1-330-558-7220
MTD Canada Limited - KITCHENER, ON N2G 4J1; Phone 1-800-668-1238