

KOBALT™

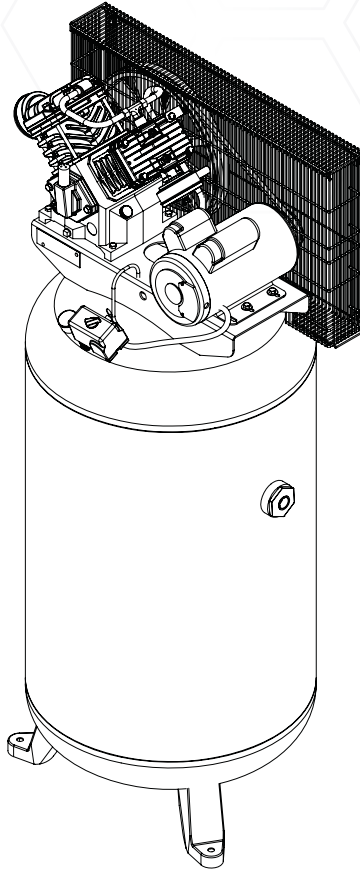

ITEM #0048365

80 GALLON STATIONARY AIR COMPRESSOR

MODEL #TQ312602

Français p. 31

Español p. 61

KOBALT® and the K Design® are registered trademarks of LF, LLC. All Rights Reserved.

ATTACH YOUR RECEIPT HERE

Serial Number _____ Purchase Date _____



Questions, problems, missing parts? Before returning to your retailer, call our customer service department at 1-888-3KOBALT (1-888-356-2258), 8 a.m. - 8 p.m., EST, Monday - Friday.

TABLE OF CONTENTS

Safety Guidelines	3
Safety Information	3
Package Contents	6
Preparation	7
Installation Instructions	8
Assembly Instructions.....	12
Operating Instructions	14
Care and Maintenance	16
Troubleshooting.....	18
Warranty	22
Replacement Parts List	24

PRODUCT SPECIFICATIONS

COMPONENT	SPECIFICATIONS
Model	TQ312602
HP	5
Number of Cylinders	4
Air Delivery @ 90 PSI	16 CFM
Voltage	230 Volts/19 Amps
Max Pressure	155 PSI

COMPONENT	SPECIFICATIONS
Oil Capacity	40 oz.
Tank Outlet Size	3/4 NPT
Length	31 in.
Width	42 in.
Height	80 in.
Weight	410 lbs.

SAFETY GUIDELINES

Please read and understand this entire manual before attempting to assemble, operate or install the product. If you have any questions regarding the product, please call customer service at 1-888-3KOBALT (1-888-356-2258), 8:00 am - 8:00 pm, EST, Monday - Friday.

This manual contains information that is very important to know and understand. This information is provided for SAFETY and to PREVENT EQUIPMENT PROBLEMS. To help recognize this information, observe the following symbols.

DANGER

Danger indicates an imminently hazardous situation which, if not avoided, WILL result in death or serious injury.

WARNING

Warning indicates a potentially hazardous situation which, if not avoided, COULD result in death or serious injury.

CAUTION

Caution indicates a potentially hazardous situation which, if not avoided, MAY result in minor or moderate injury.

NOTICE

Notice indicates important information, that if not followed, may cause damage to equipment.

SAFETY INFORMATION

CALIFORNIA PROPOSITION 65

WARNING

Handle with Care. This product or its power cord may contain chemicals known to the State of California to cause cancer and birth defects or other reproductive harm. Wash hands after handling.

WARNING



Wear Eye and Mask Protection. You can create dust when you cut, sand, drill or grind materials such as wood, paint, metal, concrete, cement, or other masonry. This dust often contains chemicals known to cause cancer, birth defects, or other reproductive harm. Wear protective gear.

GENERAL SAFETY

Since the air compressor and other components (material pump, spray guns, filters, lubricators, hoses, etc.) used, make up a high pressure pumping system, the following safety precautions must be observed at all times:

1. Read all manuals included with this product carefully. Be thoroughly familiar with the controls and the proper use of the equipment.
2. Follow all local electrical and safety codes as well as in the United States, the National Electrical Codes (NEC) and Occupational Safety and Health Act (OSHA).
3. Only persons well acquainted with these rules of safe operation should be allowed to use the compressor.
4. Keep visitors away and NEVER allow children in the work area.
5. Wear safety glasses and use hearing protection when operating the unit.



SAFETY INFORMATION

GENERAL SAFETY (Continued)

6. Do not stand on or use the unit as a handhold.
7. Before each use, inspect compressed air system and electrical components for signs of damage, deterioration, weakness or leakage. Repair or replace defective items before using.
8. Check all fasteners at frequent intervals for proper tightness.
9. Do not wear loose clothing or jewelry that will get caught in the moving parts of the unit.
10. Keep fingers away from a running compressor; fast moving and hot parts will cause injury and/or burns.
11. If the equipment should start to vibrate abnormally, STOP the motor and check immediately for the cause. Vibration is generally a warning of trouble.
12. To reduce fire hazard, keep motor exterior free of oil, solvent, or excessive grease.
13. Never attempt to adjust ASME safety valve. Keep safety valve free from paint and other accumulations.
14. Tanks rust from moisture build-up, which weakens the tank. Make sure to drain tank daily and inspect periodically for unsafe conditions such as rust formation and corrosion.
15. Fast moving air will stir up dust and debris which may be harmful. Release air slowly when draining moisture or depressurizing the compressor system.

⚠ DANGER

Risk of Personal Injury. This compressor/pump is NOT equipped and should NOT be used "as is" to supply breathing quality air. For any application of air for human consumption, you must fit the air compressor/pump with suitable in-line safety and alarm equipment. This additional equipment is necessary to properly filter and purify the air to meet minimal specifications for Grade D breathing as described in Compressed Gas Association Commodity Specification G 7.1, OSHA 29 CFR 1910. 134, and/or Canadian Standards Associations (CSA).

DISCLAIMER OF WARRANTIES

In the event the compressor is used for the purpose of breathing air application and proper in-line safety and alarm equipment is not simultaneously used, existing warranties are void, and the Manufacturer disclaims any liability whatsoever for any loss, personal injury or damage.

⚠ WARNING

Risk of Personal Injury and/or Equipment Damage. Never install a shut-off valve between the compressor pump and the tank.

⚠ DANGER



Risk of Explosion. Never attempt to repair or modify a tank! Welding, drilling or any other modification will weaken the tank resulting in damage from rupture or explosion. Always replace worn, cracked or damaged tanks.

⚠ WARNING



Risk of Fire. Motors, electrical equipment and controls can cause electrical arcs that will ignite a flammable gas or vapor. Never operate or repair in or near a flammable gas or vapor. Never store flammable liquids or gases in the vicinity of the compressor.

⚠ WARNING

Risk of Explosion. Never use plastic (PVC) pipe for compressed air. Serious injury or death could result.

SAFETY INFORMATION

GENERAL SAFETY (Continued)

WARNING



Risk of Personal Injury. Never operate compressor without a beltguard. This unit can start automatically without warning. Personal injury or property damage could occur from contact with moving parts.

WARNING

Risk of Explosion. An ASME code safety relief valve with a setting no higher than the maximum allowable working pressure (MAWP) MUST be installed in the tank for this compressor. The ASME safety valve must have sufficient flow and pressure ratings to protect the pressurized components from bursting.

WARNING

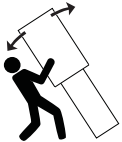

Risk of Personal Injury. This compressor is extremely top heavy. The unit must be bolted to the floor with isolation pads before operating to prevent equipment damage, injury or death.

CAUTION

Do Not Overpressure. See compressor specification decal for maximum operating pressure. Do not operate with pressure switch or pilot valves set higher than the maximum operating pressure.

CAUTION



Risk of Personal Injury. Compressor parts may be hot even if the unit is stopped.

NOTICE

Unit Care and Maintenance. Drain liquid from tank daily.

SPRAYING PRECAUTIONS

1. Do not smoke when spraying paint, insecticides, or other flammable substances.
2. Use a face mask/respirator when spraying and spray in a well-ventilated area to prevent health and fire hazards.
3. Do not direct paint or other sprayed material at the compressor. Locate compressor as far away from the spraying area as possible to minimize overspray accumulation on the compressor.
4. When spraying or cleaning with solvents or toxic chemicals, follow the instructions provided by the chemical manufacturer.

WARNING



Risk of Fire. Do not spray flammable materials in vicinity of open flame or near ignition sources including the compressor unit.

PACKAGE CONTENTS

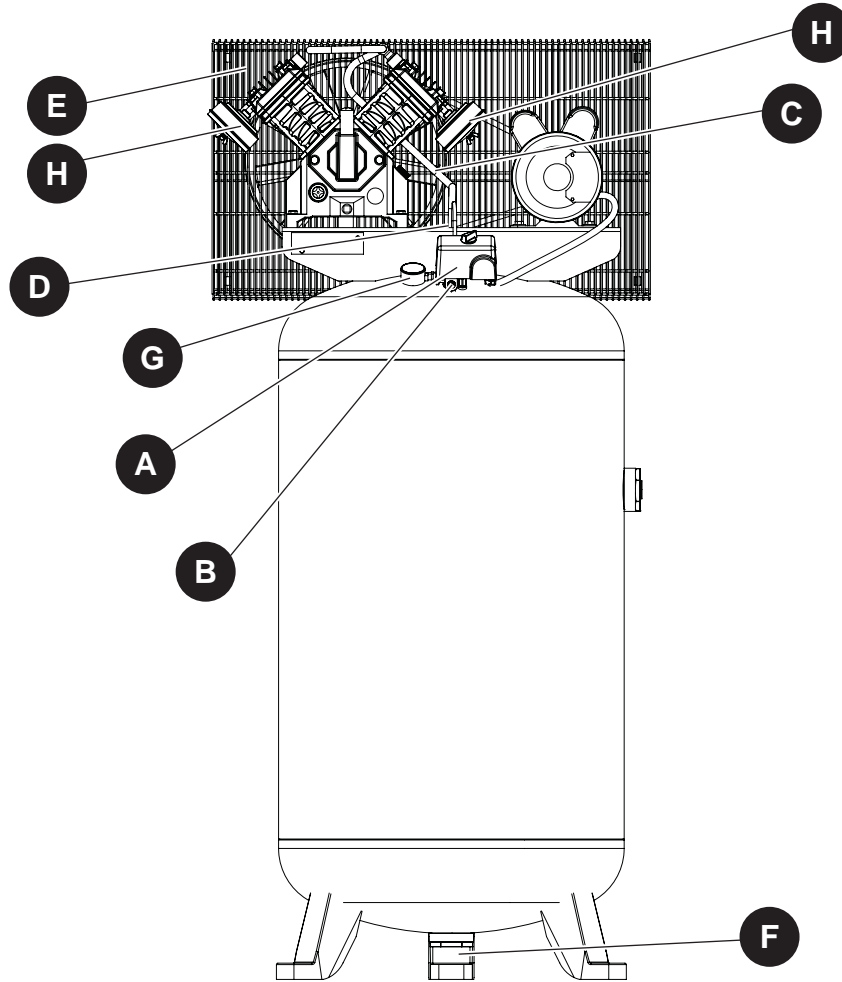

PART	DESCRIPTION	QTY.
A	<p>Pressure Switch - AUTO/OFF Switch - In the AUTO position, the compressor shuts off automatically when tank pressure reaches the maximum preset pressure. After air is used from the tank and drops to a preset low level, the pressure switch automatically turns the motor back on. In the OFF position, the compressor will not operate. This switch should be in the OFF position when connecting or disconnecting the power from the unit.</p> <p>When the pressure switch turns the motor off you will hear air leaking out of the pressure switch unloader valve for a short time. This releases the air pressure from the discharge tube and allows the compressor to restart easier.</p>	1
B	<p>ASME Safety Valve - This valve automatically releases air if the tank pressure exceeds the preset maximum.</p>	1
C	<p>Discharge Tube - This tube carries compressed air from the pump to the check valve. This tube becomes very hot during use. To avoid the risk of severe burns, never touch the discharge tube.</p>	1

PACKAGE CONTENTS

PART	DESCRIPTION	QTY.
D	Check Valve - One-way valve that allows air to enter the tank, but prevents air in the tank from flowing back into the compressor pump.	1
E	Belt Guard - Covers the belt, motor pulley and flywheel.	1
F	Bottom Drain Valve - Use this valve to drain moisture from the tank daily to reduce the risk of corrosion.	1
G	Tank Pressure Gauge - Indicates amount of air pressure stored in tank.	1
H	Air Filter - Keeps large particulates out of the air flowing into the compressor.	2

PREPARATION

Before beginning installation and/or assembly of product, make sure all parts are present. Compare parts with package contents list. If any part is missing or damaged, do not attempt to assemble or use the product.

WARNING

Risk of Personal Injury. Do not operate unit if damaged during shipping, handling or use. Damage may result in bursting and cause injury or property damage.

Estimated Installation and Assembly Time: 120 minutes

Tools Required for Installation and Assembly (not included): Safety Glasses; Work Gloves; 9/16 in. Socket and Ratchet; Tape measure; Hammer Drill and Masonry Bit; Hammer; Phillips Screwdriver; Flathead Screwdriver; Pipe Wrench; Two Adjustable Wrenches; 1/4 in. Nut Driver, Socket or Wrench; 240 Volt, 30 Amp Double Pole Circuit Breaker; Voltage Meter; Vibration Pads; 3/8 in. x 5 in. Wedge Anchors (for concrete installation)

INSTALLATION INSTRUCTIONS

UNIT INSTALLATION

⚠ WARNING

Risk of Personal Injury. Do not lift or move unit without appropriately rated equipment. Be sure the unit is securely attached to lifting device used. Do not lift unit by holding onto tubes or coolers. Do not use unit to lift other attached equipment.

NOTICE

Unit Care and Maintenance. This compressor is not intended for outdoor installation.

It is extremely important to install the compressor in a clean, well-ventilated area where the surrounding air temperature will not be more than 100°F. Do not locate the compressor air inlet near steam, paint spray, sandblast areas or any other source of contamination.

1. Unbolt the unit from the shipping skid. Use a ratchet with a 9/16 in. socket. Remove the unit from the skid. This requires at least two people - one person to walk the unit off the skid and one to help maintain balance so the unit does not topple. Place the unit where you plan to install it (at least 18 in. from any wall or surface).

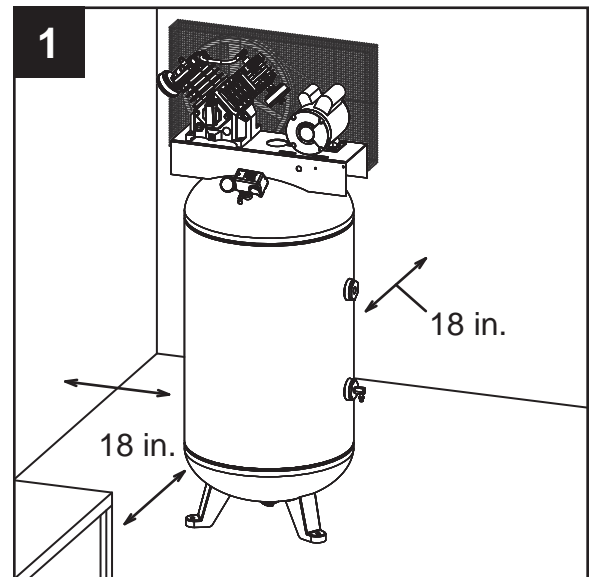

2. Place pre-drilled vibration pads (sold separately) under each foot to avoid unnecessary vibration which could damage the unit.

Using the mounting holes and the holes of the vibration pads as a guide, drill holes into concrete using a 3/8 in. masonry bit. Holes drilled must be at least 5 in. into the concrete.

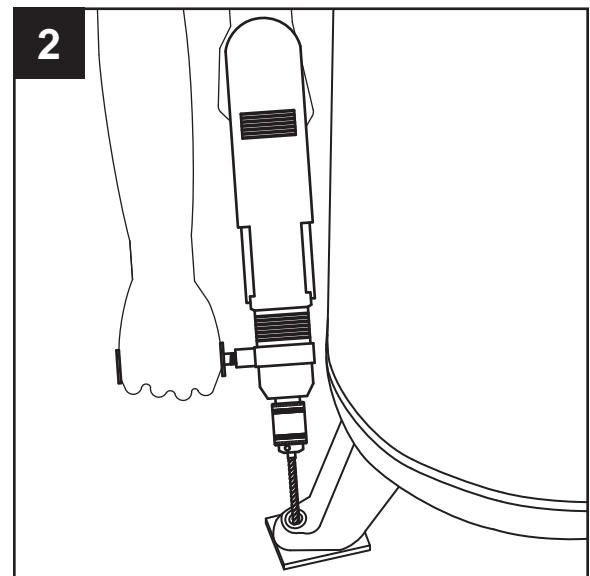

INSTALLATION INSTRUCTIONS

3. Insert mounting bolts. Use 3/8 in. x 5 in. wedge anchors (not included) to secure the unit. Place nut and washer on bolt. Thread nut onto bolt until tops are flush. Strike bolt with hammer until nut and washer are setting on top of the compressor foot.

Tighten nut using ratchet with a 9/16 in. socket until anchor is set (using installation torque specifications of bolt being used). Loosen nut to leave a 1/16 in. (1.6 mm) gap for stress relief during unit operation.

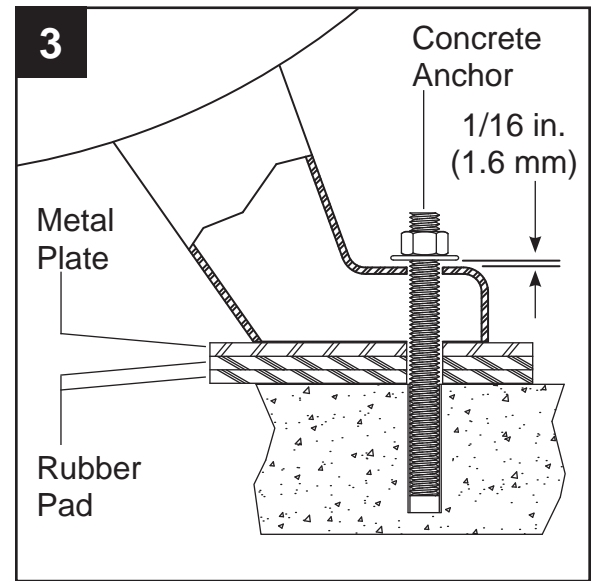

ELECTRICAL INSTALLATION

⚠ DANGER



Risk of Shock. Improperly grounded motors are shock hazards. Make sure all the equipment is properly grounded.

⚠ WARNING

Risk of Personal Injury or Damage to Personal Property. Overheating, short circuiting and fire damage will result from inadequate wiring.

⚠ WARNING



Risk of Shock. All wiring and electrical connections must be performed by a qualified electrician familiar with industrial motor controls. Installations must be in accordance with local and national codes.

⚠ WARNING



Risk of Explosion. Disconnect, tag and lock out power source, then release all pressure from the system before attempting to install, service, relocate or perform any maintenance.

NOTICE

Unit Care and Maintenance. Damage to the motor from improper electrical voltage or connection will void the warranty.

GROUNDING

This product must be grounded. Install permanent wiring from the electrical source to the pressure switch with a ground conductor connected to the grounding screw on the pressure switch. A properly sized cord with a ground conductor and plug may also be installed by the user.

INSTALLATION INSTRUCTIONS

WIRING

Local electrical wiring codes differ from area to area. Source wiring and protector must be rated for at least the amperage and voltage indicated on the motor nameplate and meet all electrical codes for this minimum. Use a slow blow fuse type T or a 240 Volt double pole circuit breaker.

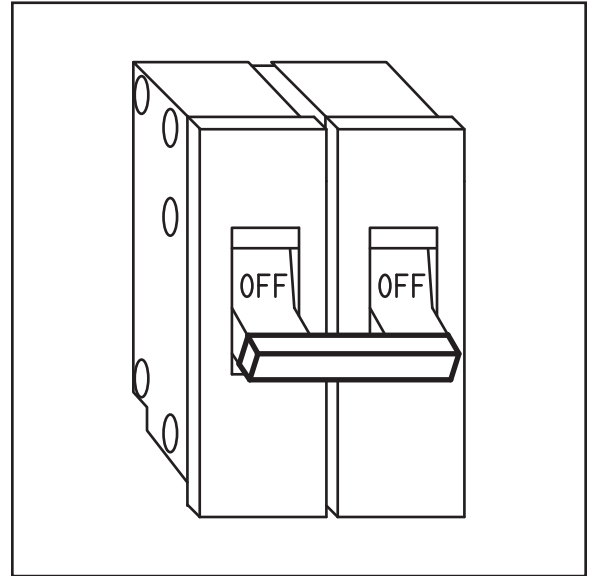

MINIMUM WIRE SIZES (must meet all codes)	
Up to 75 ft. long	10 AWG

1. Inspect the source wiring before continuing with installation. Confirm voltage with volt meter line-to-ground (see Figure 1). Volt meter should read 120 Volts.

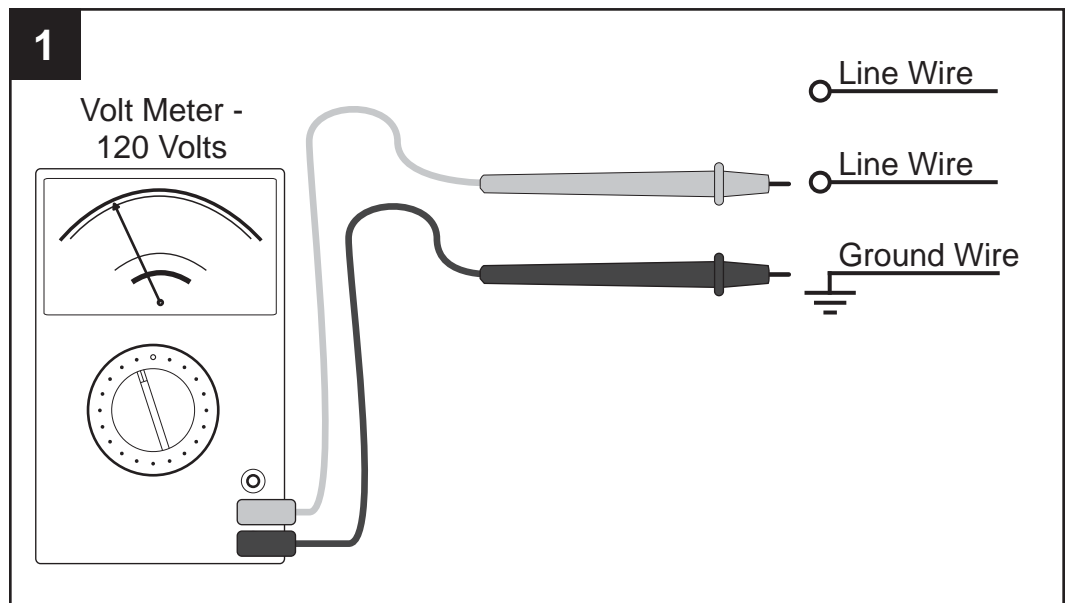

Confirm voltage with volt meter line-to-line. Volt meter should read 230/240 Volts (see Figure 2).

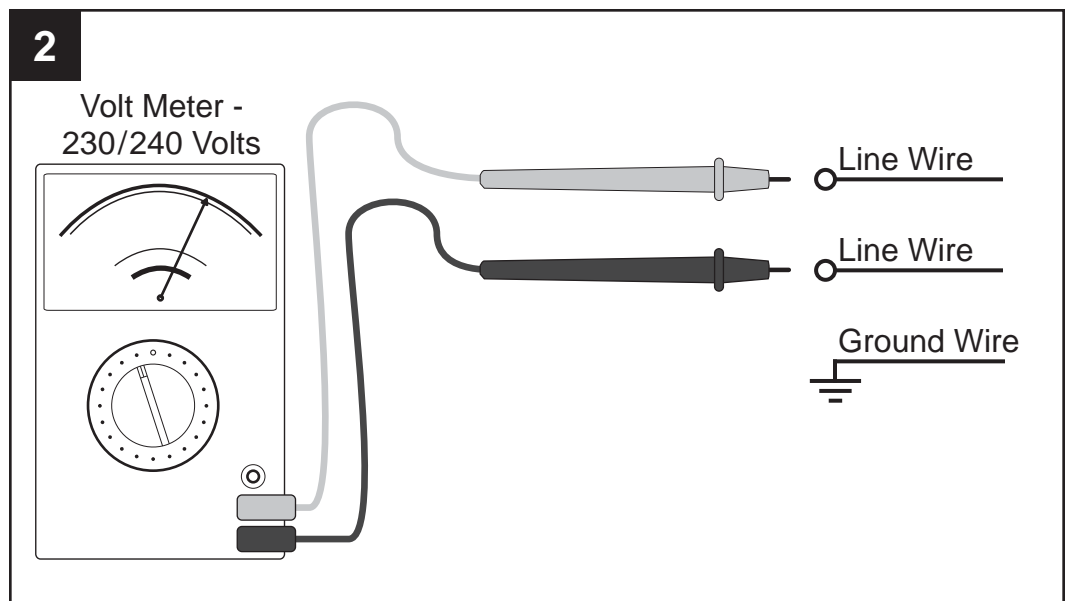

INSTALLATION INSTRUCTIONS

2. Remove the pressure switch cover by loosening the screw (see Figure 1). Use a Phillips screwdriver (not included). Pressure switch styles may vary.

⚠ WARNING



Risk of Shock. All wiring and electrical connections must be performed by a qualified electrician familiar with industrial motor controls. Installations must be in accordance with local and national codes.

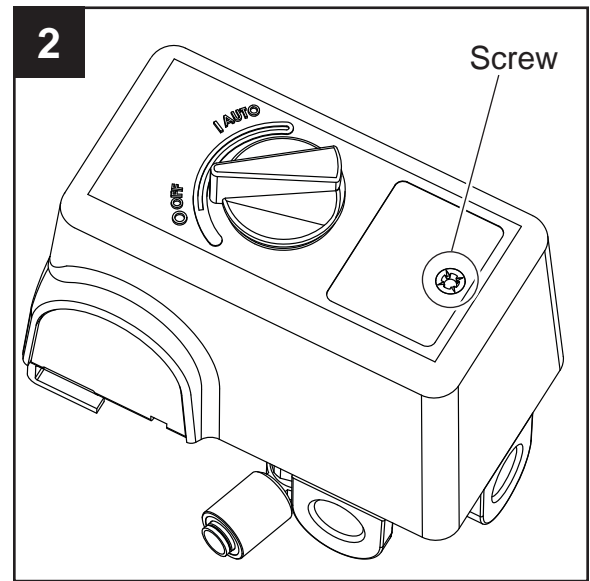

3. Familiarize yourself with the pressure switch once cover is removed.

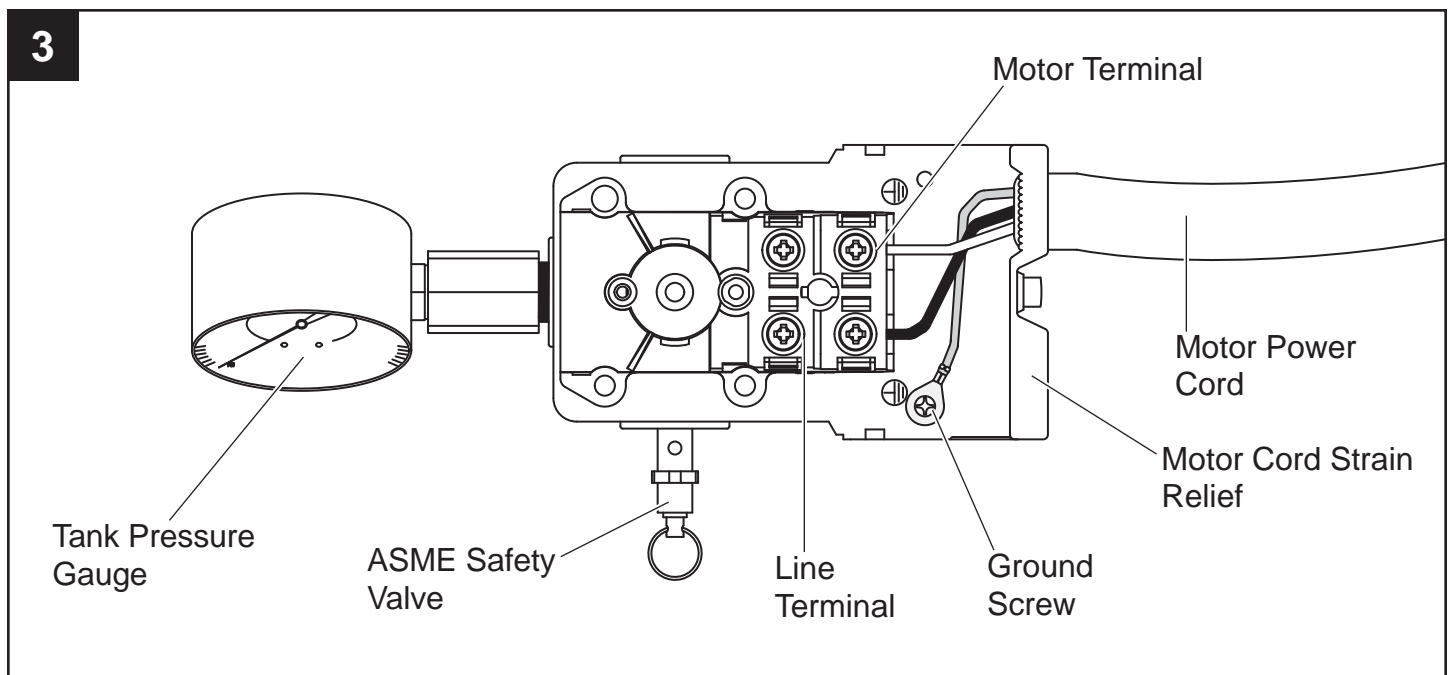

INSTALLATION INSTRUCTIONS

4. Remove ground screw. Install strain relief on pressure switch. **DO NOT** tighten strain relief on power cord until wiring is complete. Insert the bare wires (black, white, bare/green) through the strain relief.

Attach bare/green ground wire first to ground screw on pressure switch body.

Look for the "Line" markings on pressure switch. Install Line wires and tighten terminal screws.

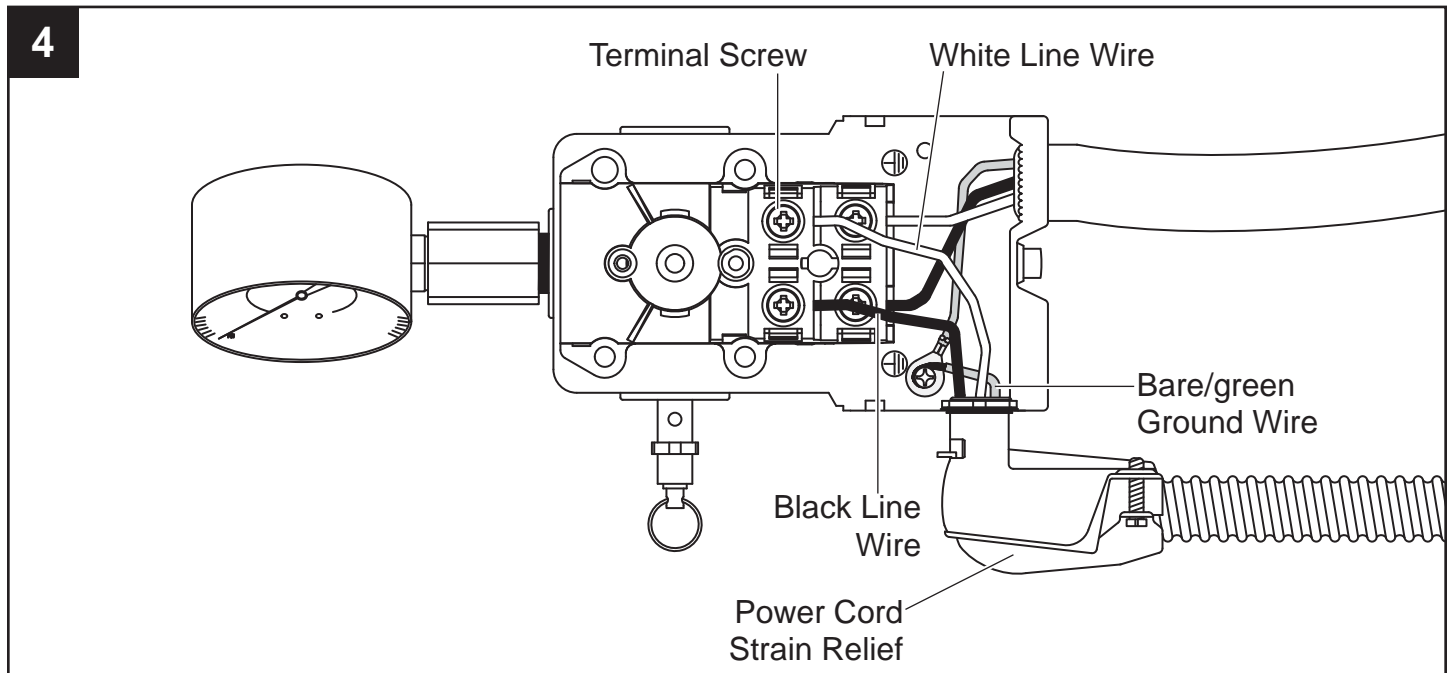

5. Tighten strain relief nut. Place a flathead screwdriver (not included) into raised notch and tap screwdriver with hammer (not included) until tight.

Tighten strain relief screws to hold power cord securely. Replace the pressure switch cover (knob must be in the same position as when removed to sit correctly in place). Tighten the pressure switch screw with Phillips screwdriver. Check that switch is in the **OFF** position. Follow break-in procedure starting on page 15.

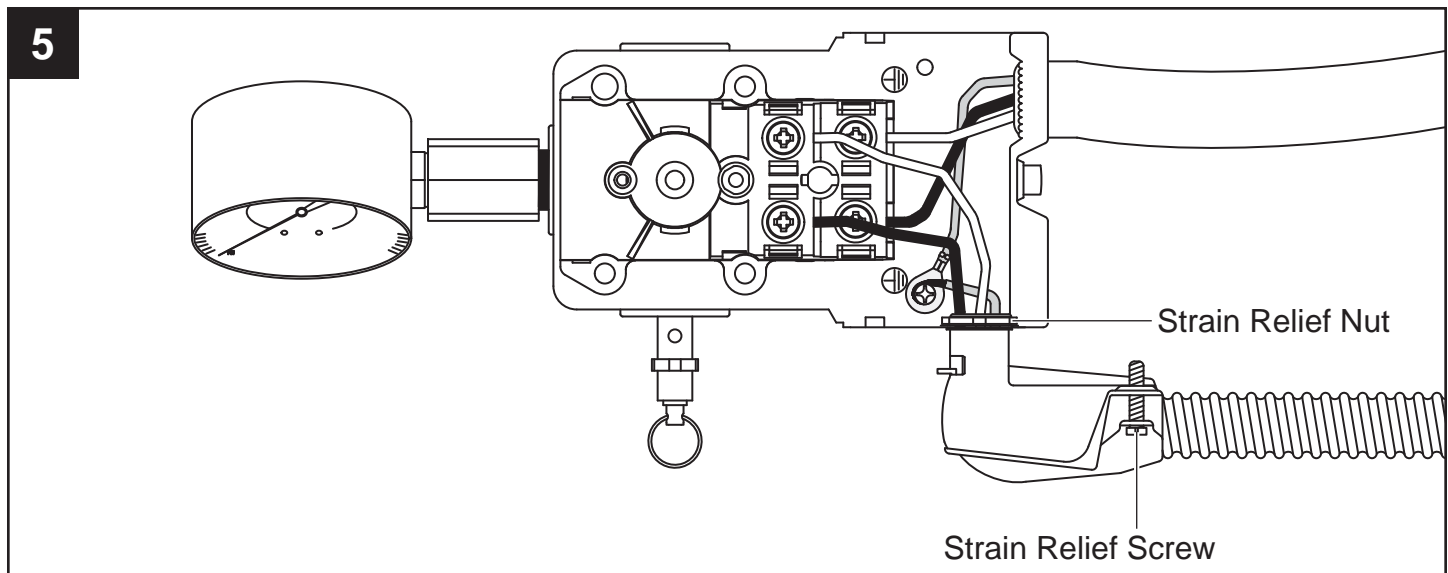

INSTALLATION INSTRUCTIONS

FILTER

Install air filters (I) on pump. Filter styles may vary.

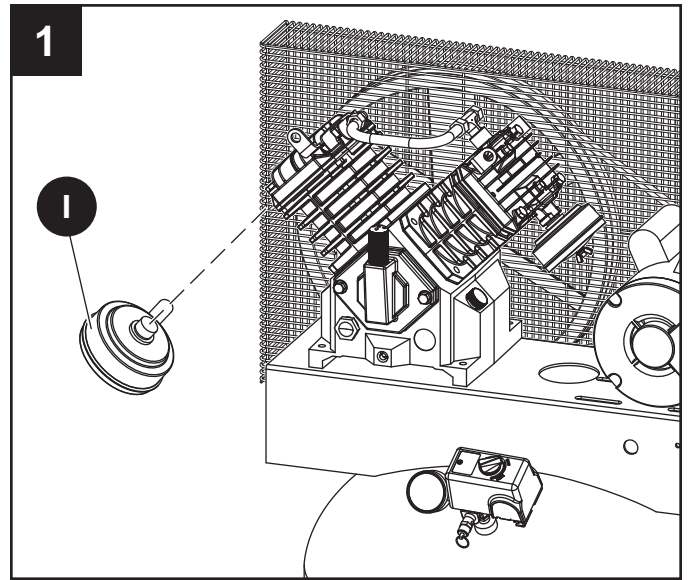

INSTALLATION INSTRUCTIONS

LUBRICATION

CAUTION

Inspect Before Use. Check for proper oil level before operating!

Remove cap on pump. Check oil level; some models are shipped with oil in the pump. See specification label on compressor pump for the proper oil capacity and oil type.

OIL INFORMATION

Kobalt Air Compressor Oil	SKU 221008
Kobalt Synthetic Blend Oil	SKU 221009
Mobil 1® synthetic 10W30	
Oil Capacity	40 ounces

Do not use regular automotive oil. Additives in regular motor oil can cause valve deposits and reduce pump life.

For maximum pump life, drain and replace oil after fifty (50) hours of run time and then follow the regular maintenance schedule outlined later in the manual.

This pump has an oil sight glass as shown in Figure 2. Oil level can be monitored and maintained as shown in Figure 3.

PIPING

⚠ WARNING

Risk of Personal Injury. Never use plastic (PVC) pipe for compressed air. Serious injury or death could result.

Any tube, pipe, or hose used must have a pressure rating higher than 175 PSI. Minimum recommended pipe size is 3/4 in. Larger diameter pipe is always better.

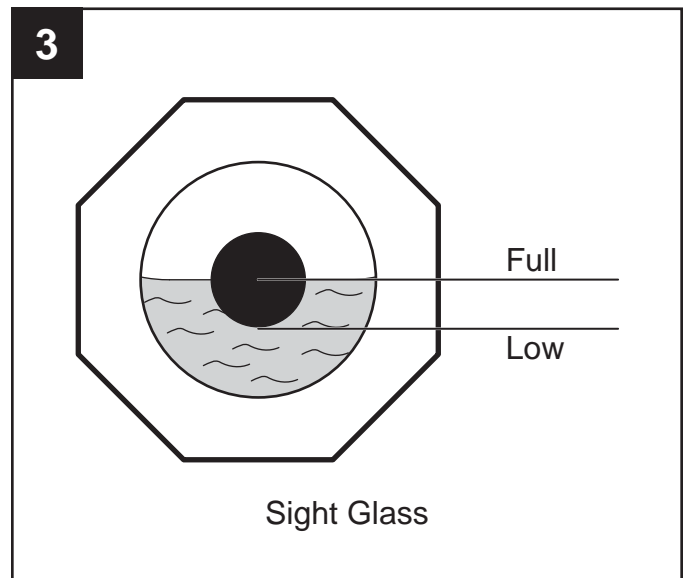
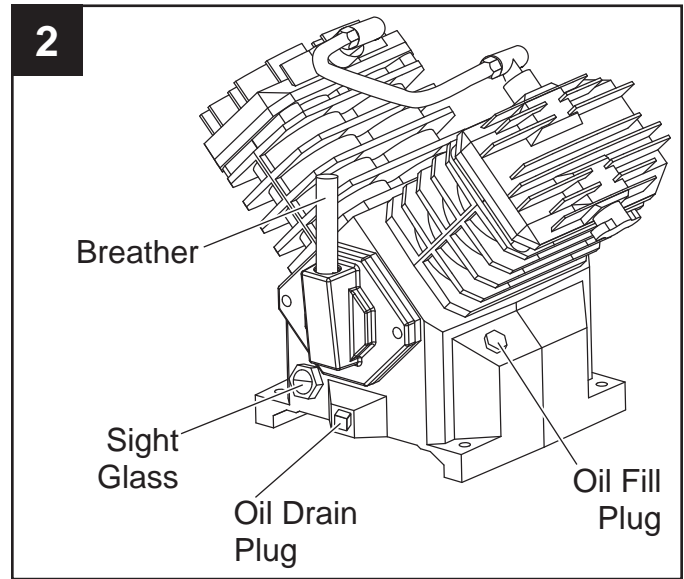

ASSEMBLY INSTRUCTIONS

START-UP/BREAK-IN PROCEDURE

⚠ WARNING

Risk of Personal Injury. Do not attach air tools to open end of the hose until start-up is completed and the unit checks okay.

1. Return power to unit from main.
2. Check oil level per the Lubrication Section of this manual.
3. Open the bottom drain valve (G) (see Figure 1). Turn outlet valve to open air flow.

4. Move pressure switch to the **AUTO** position to run the unit (see Figure 2).
5. Run the unit for thirty (30) minutes at zero (0) PSI (under no load) to break in pump parts.
6. Move the pressure switch lever or knob to **OFF** and turn tank drain valve to shut off air flow. The compressor is now ready for use.
7. Change oil after first fifty (50) hours of operation. Perform oil changes every three (3) months or two hundred (200) hours of run time, whichever comes first.

⚠ WARNING

Risk of Personal Injury. Never disconnect threaded joints with pressure in tank!

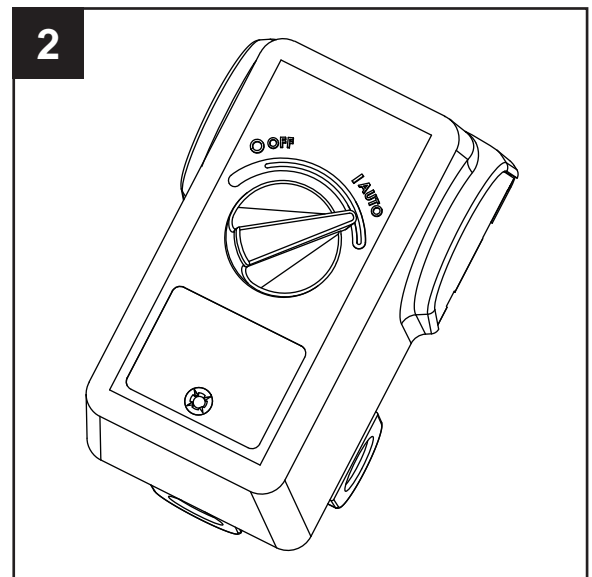
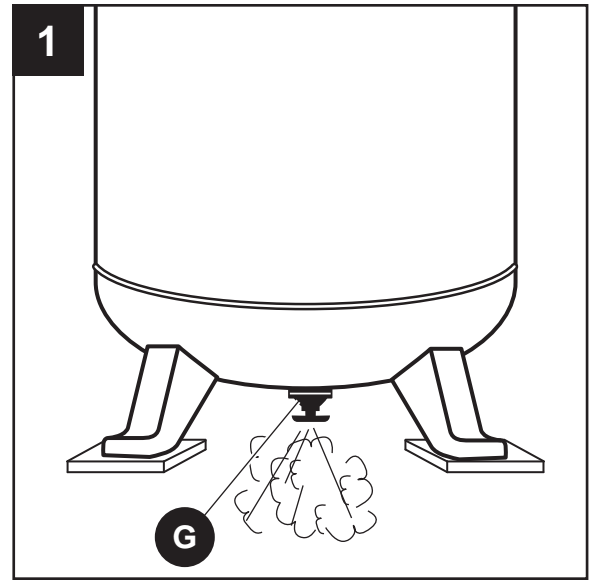

OPERATING INSTRUCTIONS

ON/OFF CYCLING OF COMPRESSOR

WARNING

Risk of Bursting. Drain tank every day to prevent corrosion and possible injury due to tank damage. For optimal performance of tank drain, tank pressure should be between 10 - 40 PSI. Do not operate drain with more than 40 PSI in tank or drain valve may be damaged. Drain tank of moisture daily using the drain valve at the bottom of the tank.

NOTICE

Unit Care and Maintenance. Drain liquid from tank daily.

In the **AUTO** position, the compressor pumps air into the tank. When a shut-off (preset “cut-out”) pressure is reached, the compressor automatically shuts off.

If the compressor is left in the **AUTO** position and air is depleted from the tank by use of a tire chuck, tool, etc., the compressor will restart automatically at its preset “cut-in” pressure. When a tool is being used continuously, the compressor will cycle on and off automatically.

In the **OFF** position, the compressor will not operate.

⚠ WARNING



Risk of Explosion. Disconnect, tag and lock out power source, then release all pressure from the system before attempting to install, service, relocate or perform any maintenance.

All repairs should be performed by an authorized service representative.

For efficient operation, perform the following maintenance.

1. Disconnect, tag and lock out power source; clean debris from motor, flywheel, tank, air lines and pump cooling fins.
2. Maintain proper oil level. Refer to Lubrication section for details.
3. Change oil.
 - a. Allow compressor to run and warm up oil. Disconnect, tag and lock out power source.
 - b. Position a pan under pump.
 - c. Remove oil drain plug (See Figure 1). Allow oil to collect in pan.
 - d. Replace drain plug, fill pump to full level (See Figure 1). See Lubrication section of this manual.
4. Drain Tank. Disconnect, tag and lock out power source; release pressure. Drain moisture from tank by opening drain valve underneath tank once tank pressure is less than 40 psi. (See Figure 2).

MOISTURE IN COMPRESSED AIR

Moisture in compressed air will form into droplets as it comes from an air compressor pump. When humidity is high or when a compressor is in continuous use for an extended period of time, this moisture will collect in the tank. When using a paint spray or sandblast gun, this water will be carried from the tank through the hose, and out of the gun as droplets mixed with the spray material.

IMPORTANT: This condensation will cause water spots in a paint job, especially when spraying other than water based paints. If sandblasting, it will cause the sand to cake and clog the gun, rendering it ineffective. A filter in the air line, located as near to the gun as possible, will help eliminate this moisture.

NOTICE

Unit Care and Maintenance. Drain liquid from tank daily.

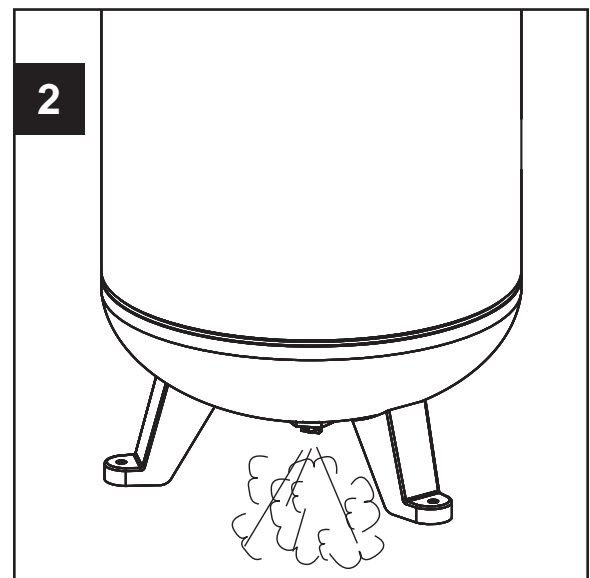
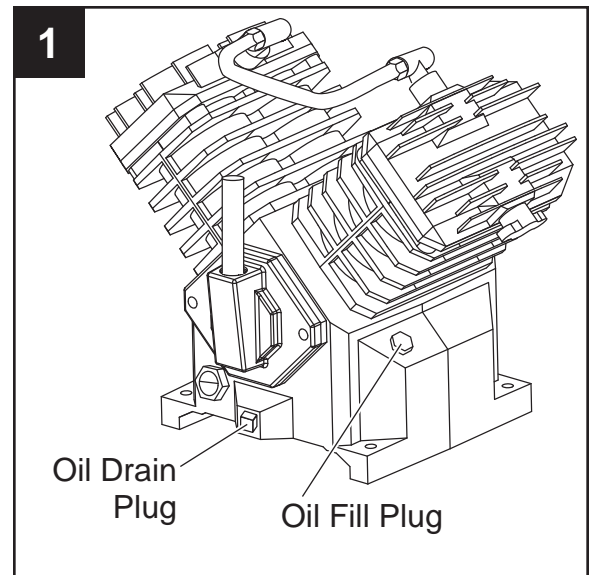

CARE AND MAINTENANCE

5. Check air filter to be sure it is clean. Replace filter if filter is dirty.
6. Check the safety valve by performing the following steps:
 - a. Restore power to unit; turn pressure switch to the **AUTO** position. Run until unit reaches 90 PSI. Turn pressure switch to **OFF** position.
 - b. Wearing safety glasses and hearing protection, pull the ring on the safety valve to release pressure from compressor tank. Protect yourself from fast-moving air being released; do not allow fast-moving air to be directed toward your face (See Figure 3).
 - c. The safety valve should automatically close at approximately 40-50 PSI. If the safety valve does not allow air to be released when you pull on the ring, or if it does not close automatically, it **MUST** be replaced.
7. Check belt for signs of excessive wear. If belt shows signs of wear, replace it. Check belt for proper tension/alignment.

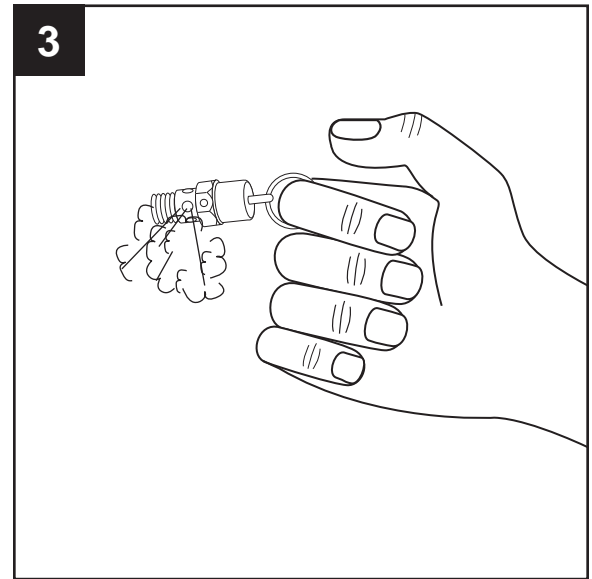

TECHNICAL SERVICE

For information regarding the operation or repair of this product, please call 1-888-3KOBALT (1-888-356-2258).

MAINTENANCE SCHEDULE				
OPERATION	DAILY	WEEKLY	MONTHLY	3 MONTHS
CHECK OIL LEVEL	●			
DRAIN TANK	●			
CHECK AIR FILTER		●		
CHECK SAFETY VALVE		●		
CLEAN UNIT			●	
CHECK BELT TIGHTNESS			●	
CHANGE OIL*				●

* Change oil after first fifty (50) hours of operation then perform oil changes every three (3) months or two hundred (200) hours of run time whichever comes first.

TROUBLESHOOTING

PROBLEM	POSSIBLE CAUSE	CORRECTIVE ACTION
Low discharge pressure	<ol style="list-style-type: none">1. Air demand exceeds pump capacity2. Restricted air intake3. Air leaks (fittings, tubing on compressor, or plumbing outside of system)4. Blown gaskets5. Leaking or damaged valves	<ol style="list-style-type: none">1. Reduce air demand or use a compressor with more capacity.2. Clean or replace the air filter element.3. Listen for escaping air. Apply soap solution to all fittings and connections. Bubbles will appear at points of leakage. Tighten or replace leaking fittings or connections. Use pipe thread sealant.4. Replace any gaskets proven faulty on inspection.5. Remove head and inspect for valve breakage, misaligned valves, damaged valve seats, etc. Replace defective parts and reassemble.

CAUTION

Unit Care and Maintenance. Install a new head gasket each time the head is removed.

TROUBLESHOOTING

PROBLEM	POSSIBLE CAUSE	CORRECTIVE ACTION
Excessive noise (knocking)	<ol style="list-style-type: none"> 1. Loose motor pulley or flywheel 2. Loose fasteners on pump or motor 3. Lack of oil in crankcase 4. Worn connecting rod 5. Worn piston pin bores 6. Piston hitting the valve plate 7. Noisy check valve in compressor system 	<ol style="list-style-type: none"> 1. Tighten pulley/flywheel clamp bolts and set-screws. 2. Tighten fasteners. 3. Check for proper oil level; if low, check for possible damage to bearings. Dirty oil can cause excessive wear. 4. Replace connecting rod. Maintain oil level and change oil more frequently. 5. Remove piston assemblies from the compressor and inspect for excess wear. Replace excessively worn piston pin or pistons, as required. Maintain oil level and change oil more frequently. 6. Remove the compressor head and valve plate and inspect for carbon deposits or other foreign matter on top of piston. Replace head and valve plate using new gasket. See Lubrication section for recommended oil. 7. Replace check valve. <div style="border: 1px solid black; padding: 5px; margin-top: 10px;"> <p style="text-align: center;">⚠ DANGER</p> <p>Risk of Explosion. Do not disassemble check valve with air pressure in tank.</p> </div>
Large quantity of oil in the discharge air NOTE: In an oil lubricated compressor there will always be a small amount of oil in the air stream.	<ol style="list-style-type: none"> 1. Worn piston rings 2. Compressor air intake restricted 3. Excessive oil in compressor 4. Wrong oil viscosity 	<ol style="list-style-type: none"> 1. Replace with new rings. Maintain oil level and change oil more frequently. 2. Clean or replace filter. Check for other restrictions in the intake system. 3. Drain down to full level. 4. Use Mobil 1® 10W-30 or full synthetic.
Water in discharge air/tank	Normal operation. The amount of water increases with humid weather	<ol style="list-style-type: none"> 1. Drain tank more often. At least daily. 2. Add a filter to reduce the amount of water in the air line.

TROUBLESHOOTING

PROBLEM	POSSIBLE CAUSE	CORRECTIVE ACTION
<p>Motor hums and runs slowly or not at all</p>	<ol style="list-style-type: none"> 1. Low voltage 2. Too many devices on same circuit 3. Loose electrical connections 4. Malfunctioning pressure switch - contacts will not close 5. Malfunctioning check valve 6. Defective unloader valve on pressure switch 7. Defective motor capacitor(s) 8. Defective motor 	<ol style="list-style-type: none"> 1. Check incoming voltage. It should be approximately 230 volts. Motor will not run properly on 208 volts. Low voltage could be due to wires (from electrical source to compressor) being too small in diameter and / or too long. Have a qualified electrician check these conditions and make repairs as needed. 2. Limit the circuit to the use of compressor only. 3. Check all electrical connections. 4. Replace pressure switch. 5. Replace check valve. <div style="border: 1px solid black; padding: 5px; margin: 10px 0;"> <p style="text-align: center;">⚠ DANGER</p> <p>Risk of Explosion. Do not disassemble check valve with air pressure in tank.</p> </div> <ol style="list-style-type: none"> 6. Replace unloader valve. 7. Replace capacitor(s). 8. Replace motor.

TROUBLESHOOTING

PROBLEM	POSSIBLE CAUSE	CORRECTIVE ACTION
Reset mechanism cuts out repeatedly or circuit breaker trips repeatedly	<ol style="list-style-type: none"> 1. Lack of proper ventilation/room temperature too high 2. Too many devices on same circuit 3. Restricted air intake 4. Loose electrical connection 5. Pressure switch shut-off pressure set too high 6. Malfunctioning check valve 	<ol style="list-style-type: none"> 1. Move compressor to well-ventilated area. 2. Limit the circuit to the use of only the air compressor. 3. Clean or replace filter element. 4. Check all electrical connections. 5. Replace pressure switch. 6. Replace check valve. <div style="border: 1px solid black; padding: 5px; margin-top: 10px;"> <p style="text-align: center;">⚠ DANGER</p> <p>Risk of Explosion. Do not disassemble check valve with air pressure in tank.</p> </div> <ol style="list-style-type: none"> 7. Replace unloader valve. 8. Replace capacitor(s). 9. Replace motor.
Tank does not hold pressure when compressor is off and the shut off valve is closed	<ol style="list-style-type: none"> 1. Air leaks (fittings, tubing on compressor, or plumbing outside system) 2. Worn check valve 	<ol style="list-style-type: none"> 1. Check all connections with soap and water solution. Tighten; or remove and apply sealant to threads, then reassemble. 2. Replace check valve. <div style="border: 1px solid black; padding: 5px; margin-top: 10px;"> <p style="text-align: center;">⚠ DANGER</p> <p>Risk of Explosion. Do not disassemble check valve with air pressure in tank.</p> </div> <ol style="list-style-type: none"> 3. Replace tank. Never repair a damaged tank.
	<ol style="list-style-type: none"> 3. Check tank for cracks or pin holes 	

TROUBLESHOOTING

PROBLEM	POSSIBLE CAUSE	CORRECTIVE ACTION
Pressure switch continuously blows air out the unloader valve	Malfunctioning check valve	<p>Replace the check valve if the unloader valve on the pressure switch bleeds off constantly when unit shuts off.</p> <div style="border: 1px solid black; padding: 5px;"> <p style="text-align: center;">⚠ DANGER</p> <p>Risk of Explosion. Do not disassemble check valve with air pressure in tank.</p> </div>
Pressure switch does not release air when the unit shuts off	Malfunctioning unloader valve on pressure switch	<p>Replace the unloader valve if it does not release the pressure for a short period of time when the unit shuts off.</p> <div style="border: 1px solid black; padding: 5px;"> <p style="text-align: center;">⚠ DANGER</p> <p>Risk of Explosion. Do not disassemble unloader valve with air pressure in tank.</p> </div>
Excessive vibration	<ol style="list-style-type: none"> 1. Loose fasteners on pump or motor 2. Belt needs replaced 3. Belt alignment 	<ol style="list-style-type: none"> 1. Tighten fasteners. 2. Replace with correct size. 3. Align flywheel and pulley.

WARRANTY

1. DURATION: From the date of purchase by the original purchaser as follows: Three Years.
2. WHO GIVES THIS WARRANTY: Campbell Hausfeld a Marmon/Berkshire Hathaway Company, 100 Production Drive, Harrison, Ohio, 45030.
3. WHO RECEIVES THIS WARRANTY (PURCHASER): The original purchaser (other than for purposes of resale) of the compressor.
4. WHAT PRODUCTS ARE COVERED BY THIS WARRANTY: This air compressor.
5. WHAT IS COVERED UNDER THIS WARRANTY: Parts and Labor to remedy substantial defects due to material and workmanship during the first year of ownership with the exceptions noted below. Parts only to remedy substantial defects due to material and workmanship during remaining term of coverage with exceptions noted below.
6. WHAT IS NOT COVERED UNDER THIS WARRANTY:
 - A. Implied warranties, including those of merchantability and FITNESS FOR A PARTICULAR PURPOSE ARE LIMITED FROM THE DATE OF ORIGINAL PURCHASE AS STATED IN THE DURATION. Some States do not allow limitations on how long an implied warranty lasts, so the above limitations may not apply to you
 - B. ANY INCIDENTAL, INDIRECT, OR CONSEQUENTIAL LOSS, DAMAGE, OR EXPENSE THAT MAY RESULT FROM ANY DEFECT, FAILURE, OR MALFUNCTION OF THE CAMPBELL HAUSFELD PRODUCT. Some States do not allow the exclusion or limitations of incidental or consequential damages, so the above limitation or exclusion may not apply to you.
 - C. Any failure that results from an accident, purchaser's abuse, neglect or failure to operate products in accordance with instructions provided in the owner's manual(s) supplied with compressor.
 - D. Pre-delivery service, e.g. assembly, oil or lubricants, and adjustment.
 - E. Items or service that is normally required to maintain the product, i.e. lubricants, filters and gaskets, etc.
 - F. Additional items not covered under this warranty:
 1. Excluded items pertaining to All Compressors
 - a. Any component damaged in shipment or any failure caused by installing or operating unit under conditions not in accordance with installation and operation guidelines or damaged by contact with tools or surroundings.
 - b. Pump or valve failure caused by rain, excessive humidity, corrosive environments or other contaminants.
 - c. Cosmetic defects that do not interfere with compressor functionality.
 - d. Rusted tanks, including but not limited to rust due to improper drainage or corrosive environments.
 - e. The following components are considered normal wear items and are not covered after the first year of ownership. Electric motor, check valve, pressure switch, regulator, pressure gauges, hose, tubing, pipe, fittings and couplers, screws, nuts, hardware items, belts, pulleys, flywheel, air filter and housing, gaskets, seals, oil leaks, air leaks, oil consumption or usage, piston rings.
 - f. Tank drain valves.
 - g. Damage due to incorrect voltage or improper wiring.
 - h. Other items not listed but considered general wear parts.
 - i. Pressure switches, air governors, load/unload devices, throttle control devices and safety valves modified from factory settings.
 - j. Damage from inadequate filter maintenance.
 - k. Induction motors operated with electricity produced by a generator.

WARRANTY

2. Excluded items specific to Lubricated Compressors:
 - a. Pump wear or valve damage caused by using oil not specified.
 - b. Pump wear or damage caused by any oil contamination.
 - c. Pump wear or damage caused by failure to follow proper oil maintenance guidelines, operation below proper oil level or operation without oil.
 - G. Labor, service call, or transportation charges after the first year of ownership of stationary compressors. Stationary compressors are defined as not including a handle or wheels.
 7. RESPONSIBILITIES OF WARRANTOR UNDER THIS WARRANTY: Repair or replace, at Warrantor's option, compressor or component which is defective, has malfunctioned and/or failed to conform within the duration of the specific warranty period.
 8. RESPONSIBILITIES OF PURCHASER UNDER THIS WARRANTY:
 - A. Provide dated proof of purchase and maintenance records.
 - B. Call customer service at 1-888-3KOBALT (1-888-356-2258) to obtain your warranty service options. Freight costs must be borne by the purchaser.
 - C. Use reasonable care in the operation and maintenance of the products as described in the owner's manual(s).
 - D. Repairs requiring overtime, weekend rates, or anything beyond the standard manufacturer warranty repair labor reimbursement rate.
 - E. Time required for any security checks, safety training, or similar for service personnel to gain access to facility.
 - F. Location of unit must have adequate clearance for service personnel to perform repairs and be easily accessible.
 9. WHEN WARRANTOR WILL PERFORM REPAIR OR REPLACEMENT UNDER THIS WARRANTY: Repair or replacement will be scheduled and serviced according to the normal work flow at the servicing location, and depending on the availability of replacement parts.
- This Limited Warranty applies in the U.S., Canada and Mexico only and gives you specific legal rights. You may also have other rights which vary from state to state or country to country.

REPLACEMENT PARTS LIST

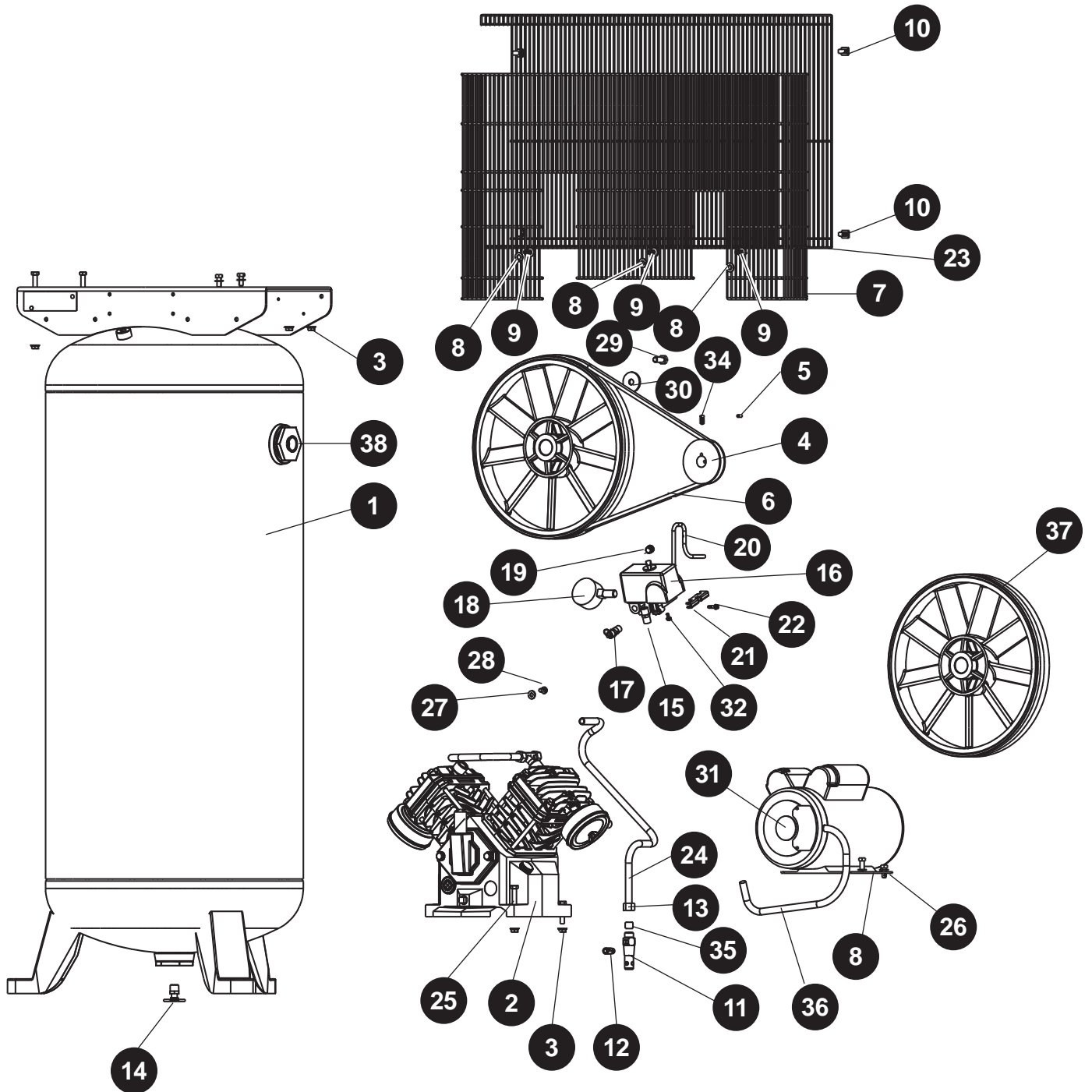

REPLACEMENT PARTS LIST

For replacement parts, call our customer service department at 1-888-3KOBALT (1-888-356-2258), 8:00 am - 8:00 pm, EST, Monday - Friday.

PART	DESCRIPTION	PART NUMBER	QTY.
1	Tank, 80 Gallons	AR232401CG	1
2	Compressor Pump	TQ3010	1
3	Spinlock Nut, 5/16"-18	-	8
4	Motor Pulley	PU017001AV	1
5	Motor Key	KE001600AV	1
6	Belt, A56	BT013101AV	1
7	Belt Guard Back	BG307400AV ■	1
8	Washer, 5/16"	■	7
9	Self Tapping Screw, 5/16"-12	ST016500AV ■	3
10	Plastic Retaining Clip	ST199700AV ■	4
11	Check Valve	CV223300SJ ●	1
12	Quick Connect Fitting, 1/4" Tube x 1/8" NPT	●	1
13	Compression Nut, 1/2"	ST033001AV ●	1
14	Draincock, 3/8"	ST127700AV	1
15	Hex Pipe Nipple, 1/4" NPT	HF002401AV	1
16	Pressure Switch	CW209300AV	1
17	ASME Safety Valve, 175PSI	V-215109AV	1
18	Pressure Gauge, 300PSI	GA031900AV	1
19	Plug, 1/4" NPT	ST022500AV	1
20	PTFE Tube, 1/4" x 13"	ST117802AV ●	1
21	Pressure Switch Cord Grip	CW209700AV	1
22	Strain Relief Screw	ST209800AV	1
23	Belt Guard Front	BG307500AV ■	1
24	Exhaust Tube , 1/2"	TQ901600AP ●	1
25	Hex Head Bolt, 5/16"-18 x 1.5"	-	4
26	Hex Head Bolt, 5/16"-18 x 0.75"	-	4
27	Washer, 1/4"	ST070910AV	1
28	Self Tapping Screw, 1/4"-20 x 0.5"	TF004801AV	1
29	Flywheel Bolt, M6-1.5 6H LH	TQ901400AV	1
30	Flywheel Washer, M6	TQ005500AV	1
31	Motor, 5HP 230V 1PH	MC035700IP	1
32	Hex Head Self Tappin Screw. #8 x 3/8"	ST074407AV	2
33	Wire Nut, 18-10 AWG (Not Shown)	ST073005AV	2
34	Set Screw, 1/4"-20 x 1/2"	ST012200AV	1
35	Brass Ferrule, 1/2" Tube	ST032900AV ●	1
36	Motor Power Cord	EC014800AV	1
37	Pump Flywheel	PU017100AV	1
Kits			
●	Unloader Tube Kit	CE410151AV	
■	Belt Guard Kit	CE410152AV	

REPLACEMENT PARTS LIST

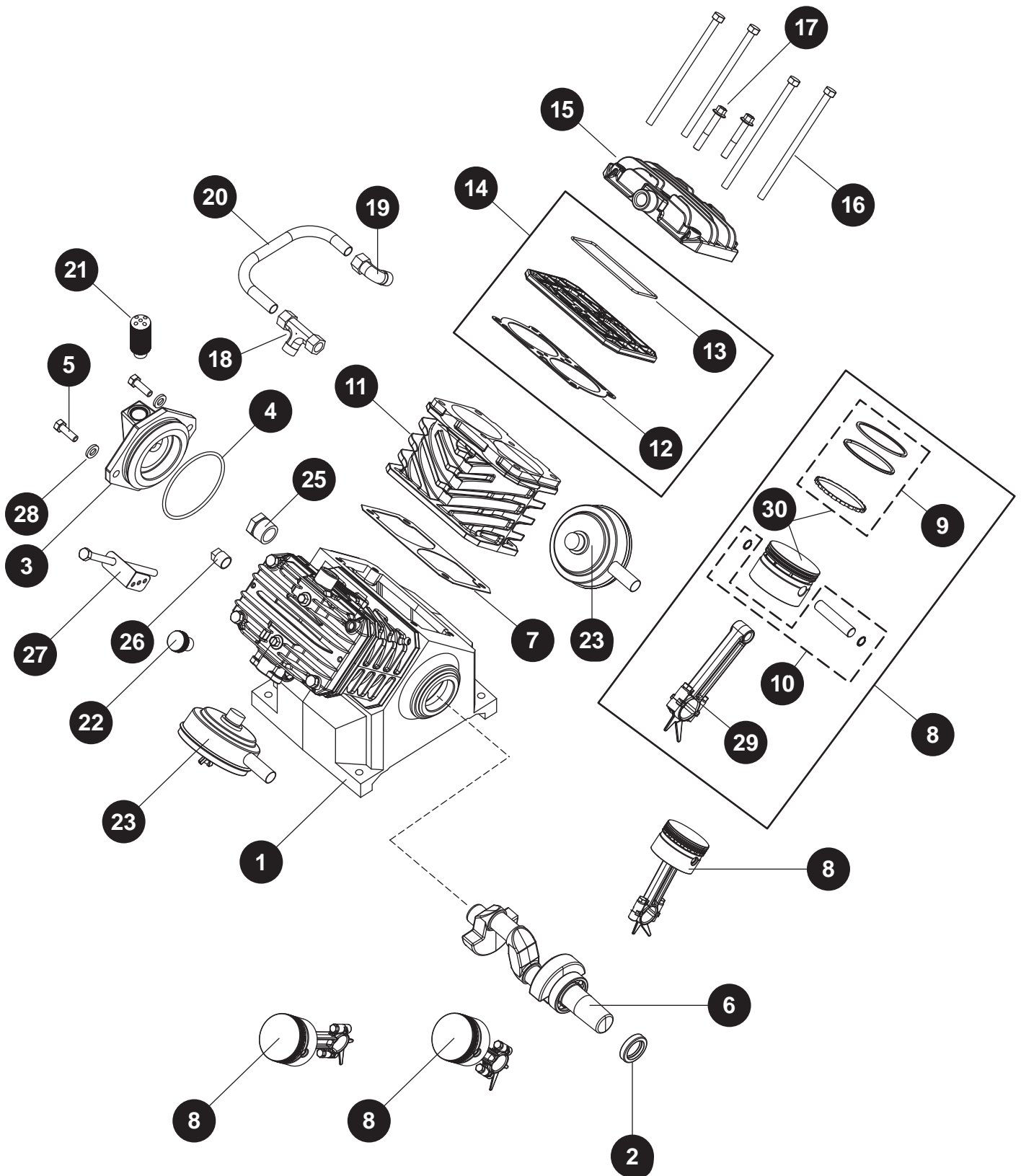

REPLACEMENT PARTS LIST

For replacement parts, call our customer service department at 1-888-3KOBALT (1-888-356-2258), 8:00 am - 8:00 pm, EST, Monday - Friday.

PART	DESCRIPTION	PART NUMBER	QTY.
1	Crankcase	--	1
2	Oil Seal	ST120000AV	1
3	Bearing Cap	TQ010201AV	1
4	O-Ring	■	1
5	Hex Head Cap Screw M8 x 25 mm	*	2
6	Crankshaft and Bearing Assembly	--	1
7	Crankcase Gasket	■	2
8	Connecting Rod / Piston Assembly Kit	TQ901500AV	4
9	Piston Ring Sets (two sets)	VT911200AV	2
10	Wrist Pin Kit [includes retaining rings]	TQ901800AV	4
11	Cylinder	VT040915AV	2
12	Cylinder Gasket	■	2
13	Molded O-Ring	■	2
14	Valve Plate Kit	VT491100AV	2
15	Cylinder Head	▲	2
16	Hex Head Cap Screw M8 x 150 mm	▲	8
17	Flange Head Screw	▲	4
18	Exhaust Tee Fitting	TQ901100AV	1
19	Exhaust Elbow Fitting	TQ901200AV	1
20	Exhaust Tube	TQ901300AV	1
21	Breather	VH901100AV	1
22	Oil Fill Plug	VH900800AV	1
23	Air Filter with Element	VH901700AV	2
24	Air Filter Element only (△)	VH901800AV	2
25	Sight Glass	VH901000AV	1
26	Pipe Plug 1/4 in. NPT	ST022500AV	1
27	Belt Guard Bracket	--	1
28	Brass Washer	ST070925AV	2
29	Connecting Rod	TQ010901AJ	4
30	Piston with Rings Kit	TQ901700AV	4

REPLACEMENT PARTS KITS

▲	Cylinder Head and Fasteners Kit	TQ900800AJ
■	Gasket Kit	TQ901001AJ
△	Not shown	
*	Standard hardware item	
--	Not available	

NOTES
