

30" DOUBLE WALL OVEN E30EW85EPS



30" Double Wall Oven Specifications

- Product Weight – 315 Lbs.
- Connected Load (kW Rating) – 240/208 Volts = 8.0/6.0 kW
- Amps @ 240/208 Volts = 33.3/28.9 Amps
- Single phase 3- or 4-wire cable, 120/240 or 120/208 Volt, 60 Hertz AC only electrical supply with ground required on separate circuit fused on both sides of line.
- Always consult local and/or national electric codes.
- Allow at least 23-1/4" clearance for oven door depth when open.
- Suggested distance from floor is 11-1/2". Minimum required distance is 4-1/2".
- Minimum 24" deep, oven cutout dimension is critical for proper installation. If oven's face profile does not fit flush against cabinet, or if noise is heard from oven's convection system, verify dimension.
- Full oven base of solid plywood or similar material required, capable of supporting 400 Lbs.
- Base must be level and cabinet front must be square.
- Wall Oven not approved for stackable or side-by-side installation.

Note: Refer to Product Installation Guide for detailed instructions on the web at www.electroluxusa.com.

Wave-Touch™ Control Panel Technology

Just a light touch anywhere on the live control panel activates the lighted controls.

Intelligent Electronic Oven Control

Our fully featured electronic oven control ensures accurate cooking time and temperature. When you are looking for quality baking and broiling results every time, this oven delivers.

Both Ovens Feature:

Smooth-Glide™ Oven Racks

Imagine oven racks that glide with unparalleled ease and extend fully for effortless access to your meal. We designed a centered easy-grip handle and a patented ball-bearing rack system for smooth-gliding performance with the touch of a finger.

Cool-Touch™ Oven Door

Introducing the coolest oven door in the industry, literally. The cool-to-the-touch all glass door design has an expansive glass front panel that allows you to clearly see what you are cooking. And because it is all glass, when it comes time for cleanup, spills and splatters wipe up with ease.

Third Element European Convection System

By adding a third cooking element and a new convection conversion option, heat is distributed faster and more evenly throughout the oven. Cooking every meal to perfection has never been easier.

Hidden Bake Element

For safe and efficient cleanup, the lower heating element is protected by a porcelain plate cover.

Halogen Oven Lighting

Carefully positioned halogen lights illuminate the oven interior, providing you with a more accurate view of the food you are preparing so you can have meals that turn out just the way you planned.

30" DOUBLE WALL OVEN

Configuration	Double
---------------	--------

OVEN FEATURES

Oven Cavity (both ovens)	4.2 Cu. Ft.
Cobalt Blue Interior	Yes
3rd Element European Convection System	Yes
Hidden Bake Element	Yes
Convection Conversion	Yes
Preheat Control	Yes
Keep Warm	Yes
Light Clean/Heavy Clean	Yes
Self-Cleaning with Auto-Safety Latch™	Yes
Self-Cleaning Cycle	Yes
Self-Cleaning Rack Removal Alert	Yes
Dual Radiant™ Baking System	Yes
Eight-Pass Bake & Broil	Yes
Smooth-Glide™ Racks	6
Standard Racks	2
Halogen Lighting	Yes
Porcelain Broiler Pan with Grill	Yes

CONTROL PANEL FEATURES

Electronic Oven Control	Yes
Electronic Clock/Timer	Yes
Electronic Temperature Display	Yes
Glass Wave-Touch™ Control with Blue LED Display	Yes
Toggle Control	Yes
Automatic Oven – Delay, Cook & Off	Yes
Child-Resistant Lockout	Yes
Automatic Oven Shutoff – 12 Hour	Yes
Auto Set™ Control – Convection	Yes
Programmable for °F or °C	Yes
Integrated Halogen Oven Light – Touch Pad	Yes

DOOR STYLE

Cool-Touch™ Door	Yes
Removable Door	Yes
Extra-Large Window	Yes
Stainless Door Handle/Towel Bar	Yes

SPECIFICATIONS

Cutout Dimensions –	
Height	51" min. 51-3/4" max.
Width	28-1/2" min. 29" max.
Depth	24"
Amps @ 240/208 Volts	33.3/28.9 Amps
Connected Load (kW Rating) - 240/208 Volts	8.0/6.0 kW
Bake Element - 240/208 Volts	3400 W
Broil Element - 240/208 Volts	4000 W
Armored Electrical Cable	Included
Product Weight	315 Lbs.
Shipping Weight	372 Lbs.
UPC (0-57112-)	08897-6

NOTE: Always consult local and/or national electric codes. Refer to Product Installation Guide for detailed installation instructions on the web at www.electroluxusa.com.

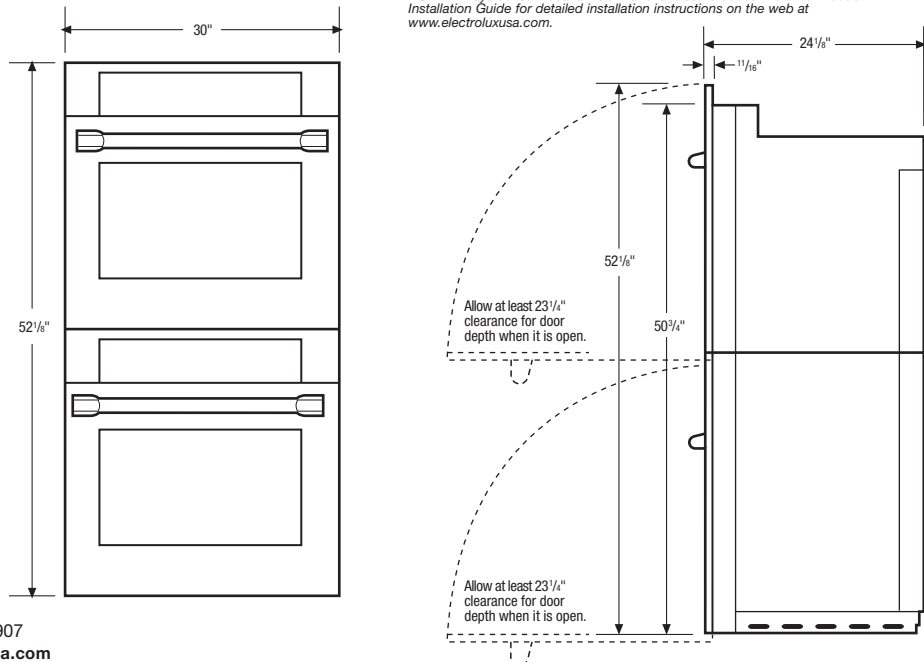

USA • 250 Bobby Jones Expressway • Augusta, GA 30907
1-877-4electrolux (1-877-435-3287) • www.electroluxusa.com

CANADA • 5855 Terry Fox Way • Mississauga, ON L5V 3E4
1-800-668-4606 • www.electroluxca.com