

SAVE THESE INSTRUCTIONS

DEALER/INSTALLER: GIVE TO HOMEOWNER

OCEAN BLUE

**“ABOVE GROUND” POOL STEPS
FOR FLAT BOTTOM POOLS**

ASSEMBLY AND INSTALLATION MANUAL



Part No. 400600 (30" STEP)



Part No. 400650 (38" STEP)



OCEAN BLUE POOL STEP

For Flat Bottom Pools -

MODEL 400600 (30") & MODEL 400650 (38") STEP

ASSEMBLY INSTRUCTIONS - PLEASE READ BEFORE ATTEMPTING ASSEMBLY

QTY	PART NUMBER	DESCRIPTION
2 -	490600	side panel
4 -	490601	30" step riser [model 400600]
4 -	490611	38" step riser [model 400650]
2 -	490602	30" step tread [model 400600]
2 -	490612	38" step tread [model 400650]
2 -	490603	30" locating tread [model 400600]
2 -	490613	38" locating tread [model 400650]
2 -	490604	short post
2 -	490605	long post
2 -	490606	handrail
4 -	490607	foot pads
2 -	490609	deck connectors
1 -	490610	step hardware/safety pack includes:
2 -		white plugs
2 -		safety labels
8 -		1/4" x 20 x 2-1/2" bolts
8 -		1/4" x 20 hex nuts
8 -		1/4" x 20 plastic acorn nuts
12 -		#10 x 1-1/4" self tapping screws

Tools Needed for Assembly

Cordless drill with Phillips head	1/4" Drill Bit
Rubber Mallet	7/16" Wrench
Phillips Screwdriver	Pliers

50 LBS. SAND REQUIRED

STEP ASSEMBLY:

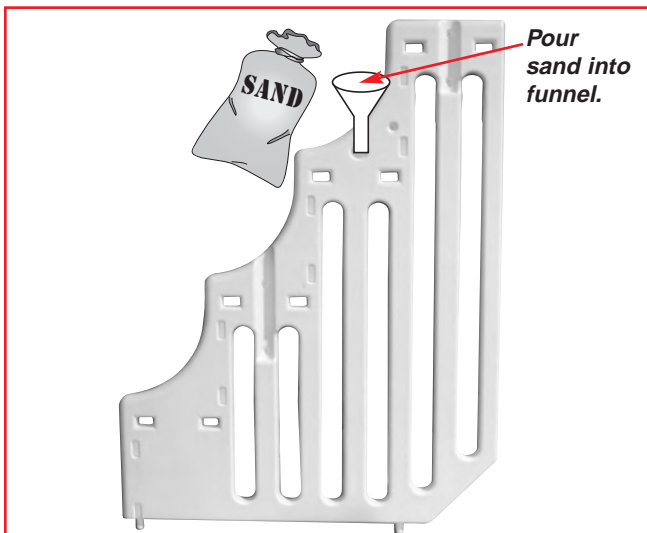

#1: Using a funnel pour 25 lbs of dry play sand into each side panel. Shake the panel to settle sand to the bottom. Cap the fill holes using two white push plugs from the hardware bag.

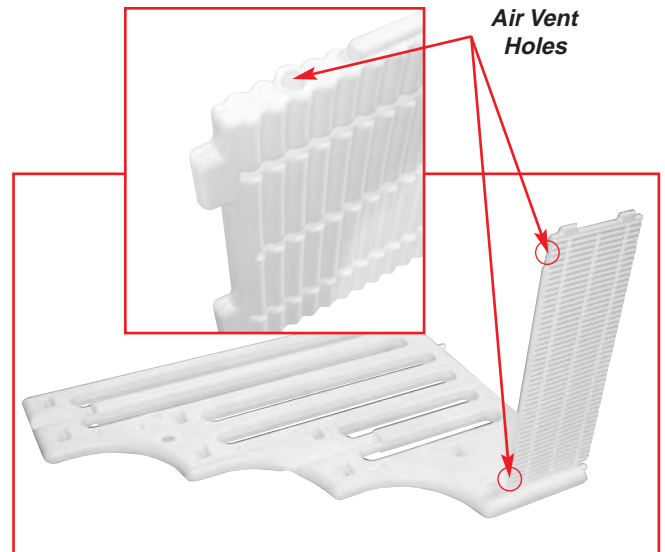

#2: Lay one of the side panels down on a clean flat surface. Starting with the bottom riser place the two tabs located on end of riser into the two slots located in the side panel and push down until seated. The air vent holes located on top edge of riser must face upwards.

STEP ASSEMBLY: (Cont'd.)

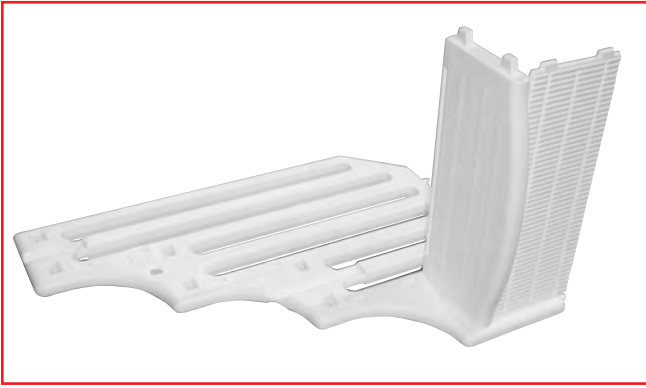

#3: Position a step tread over the riser and into the slots on the side panel. With a rubber mallet tap tread down until locked into place. It will require several hard hits with a rubber mallet.

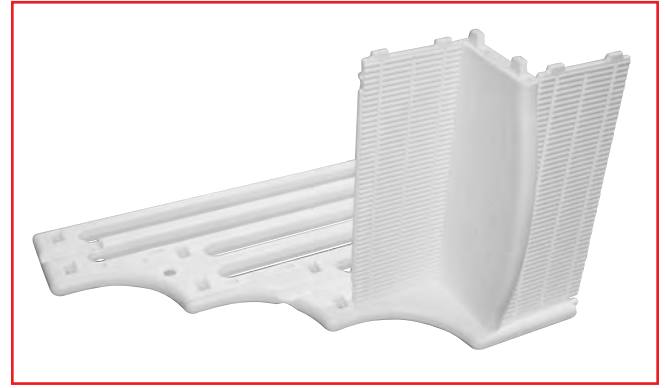

#4: Place the next riser into the slots on the side panel just above the tread and push down until seated. Air vents must be facing up.

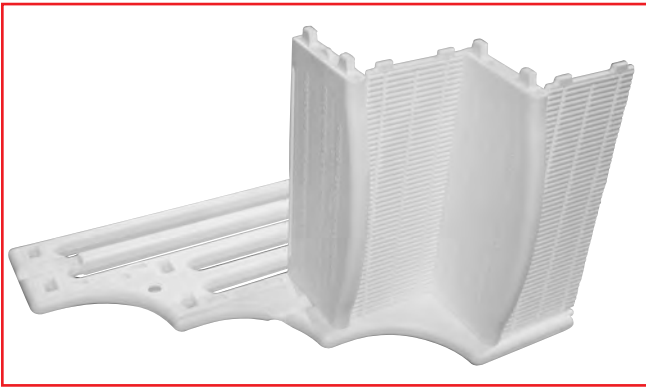

#5: Place a locating tread into the slots and over the riser. With a rubber mallet tap tread down until locked into place.

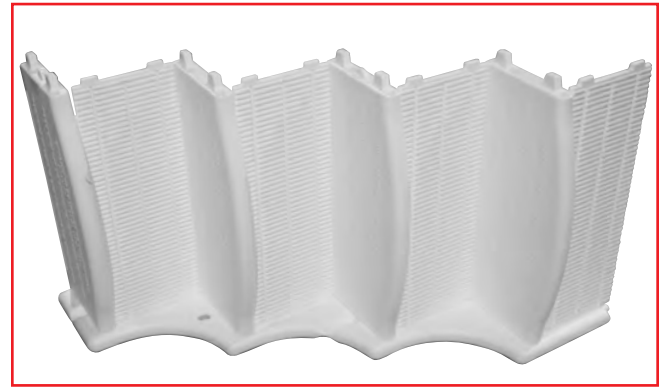

#6: Install one more locating tread, one more step tread and two risers.



#7: Place the second panel over the risers and step treads making sure to align all the tabs on the side panel. Using a rubber mallet tap down on the side panel until all treads are locked into place. It will require several hard hits with a rubber mallet.



#8: Position a foot pad over the round extension located on the bottom of side panel. It will require several hard hits with a rubber mallet to force the foot pad over the extension. Repeat to install the three remaining foot pads. Stand the step upright.

STEP ASSEMBLY: (Cont'd.)

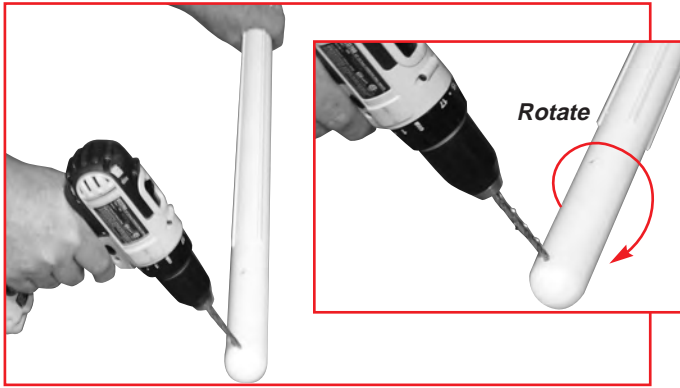

#9: Using a 1/4" drill bit drill two holes in each of the long posts and two holes in each of the short posts at the marks. To insure a straight hole do not drill all the way through. Drill one side at the mark then rotate to drill the opposite side at the mark.

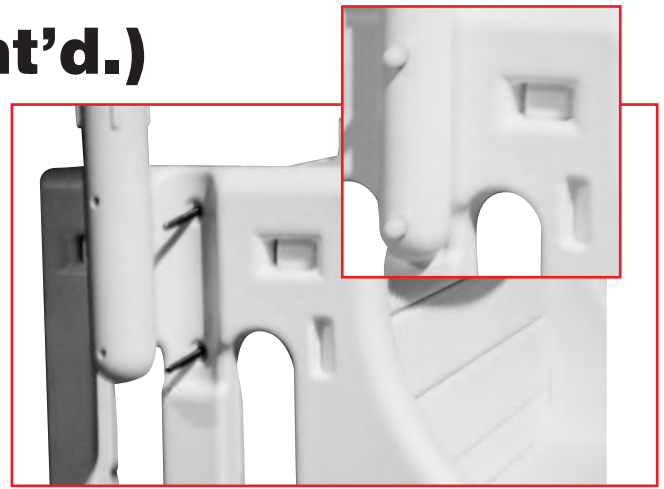

#10: Align the two holes in the short post with the two holes in the upper post location on the side panel. Push the two-2-1/2" bolts through the holes from the inside of step to the outside. Thread on two of the 1/4" x 20 hex nuts and tighten with a 7/16" wrench. Cap the end of screws using plastic acorn nuts.



#11: Repeat Step #10 to install second short post on opposite side panel.



#12: Using the same procedure as in Step #10 attach both long posts to the lower post locations on both side panels.



#13: If step is going to be attached to a deck, slide the two deck connectors over the two short posts before placing handrails on posts.

Note: if step is going to be used with outside safety ladder model # 400900 the deck connectors will not be used.



#14: Place handrails over posts and tap down into place. Attach the handrail to each post using a #10 x 1-1/4" self tapping screw.

INSTALLING STEP INTO SWIMMING POOL

YOUR POOL STEP WEIGHS 100 PLUS POUNDS WITH THE REQUIRED SAND IN THE SIDE PANELS. IT WILL REQUIRE 2-3 PEOPLE TO LIFT STEP OVER POOL SIDE WALL.

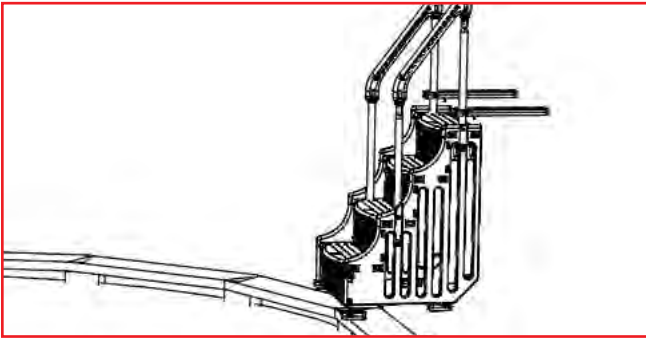

#1: Remove the two white caps from the side panel fill holes. Carefully lift pool step over pool wall being careful not to damage pool liner or pool frame.

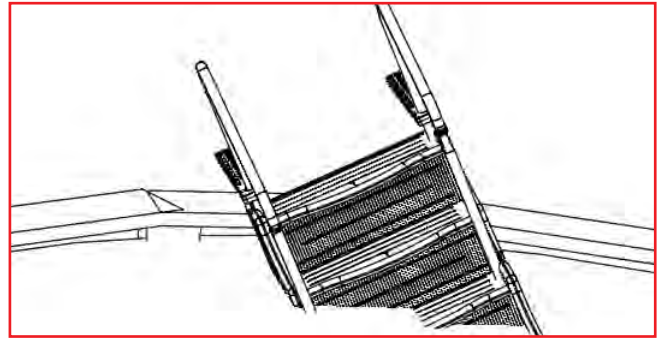

#2: Step will float until the air is out of step components. To remove the air, tilt the step to the left until the fill hole in side panel is under water. Keep tilted until all air bubbles stop then cap fill hole. Next tilt the step to the right until all air bubbles stop then cap fill hole. At this time, the step should be sitting firmly on bottom of pool. If not, air is still trapped in components and step will have to be tilted again.

IF STEP IS BEING USED WITH OUTSIDE SAFETY LADDER MODEL # 400900 REFER TO SAFETY LADDER INSTRUCTIONS FOR PROPER ATTACHMENT TO LADDER.

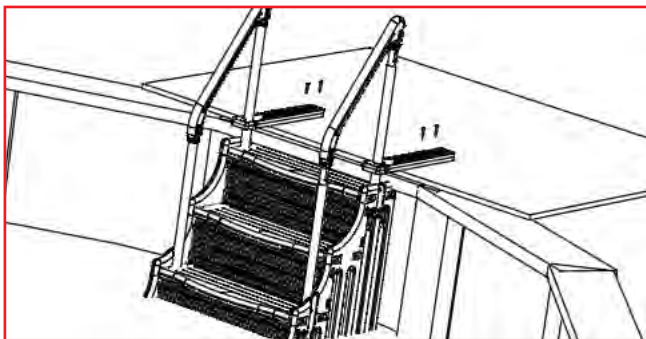

#3: If step is being used with pool deck rotate the two deck connectors to sit on pool deck and attach using two - #10 x 1-1/4" self tapping screws in each connector.

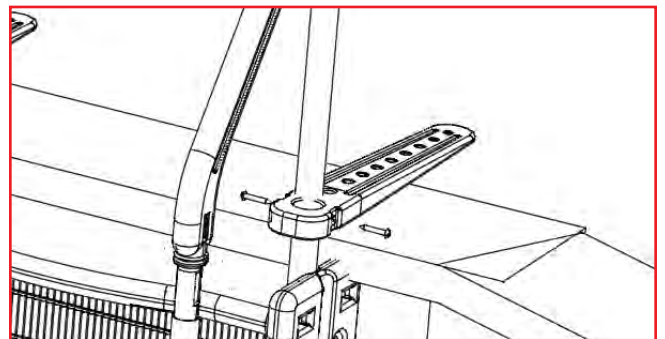

#4: Attach the deck connectors to the handrail posts using two - #10 x 1-1/4" self tapping screws.



#5: Apply the two safety labels on the upper handrail posts so they are visible when entering the swimming pool.

SAFETY RULES

- One person on the step at a time
- **DANGER:** shallow water no jumping or diving from step or pool deck
- **ALWAYS** have competent adult supervision when pool is in use
- **NEVER** leave the pool unattended
- **NO** unauthorized entry into pool
- To prevent entrapment or drowning step must be installed up to the inside of pool wall
- Weight limit **400 lbs**
- Exceeding the recommended weight limit may cause step to fail

IMPORTANT FOR YOUR SAFETY

- * Consult your local building department before installation of your pool and equipment.
- * Check the contents of the carton with the parts list for this step.
- * **DO NOT** attempt to assemble or install this step if there are **ANY** shortages of parts or hardware.
- * For proper assembly and installation follow all instructions in the sequence shown.
- * Before using the product, after assembly and installation, go over the instructions and procedures again to make sure nothing has been overlooked.
- * Be sure and safe. The manufacturer **IS NOT** responsible for improper assembly or installation.

DANGER: only use a cordless drill for assembly and installation. **NEVER** use a corded electric drill in or around swimming pool.

WINTERIZING: remove the two white caps from the side panels. Disconnect the step from deck or outside safety ladder and lift out of the water. Once out of water tip step on its side to drain water. Tip step on its other side to finish draining.

NOTE: sand remains in step — do not remove sand.

OCEAN BLUE WATER PRODUCTS WARRANTY

Ocean Blue Water Products warrants their swimming pool steps to be free from defects in workmanship for one year from date of purchase.

DO NOT RETURN DEFECTIVE PART TO DEALER

The defective part should be returned, postpaid, to:
Ocean Blue Water Products
4646 W. Lake Street
Chicago, IL 60644

Enclose proof-of-purchase (receipts, etc.) showing date purchased, your name, address, and daytime phone number. You will be notified of cost to replace part.

This warranty gives you specific legal rights, and you may also have other rights which may vary from state to state.

Made in U.S.A.



Printed in U.S.A.