

CHAMPION

POWER EQUIPMENT™

OWNER'S MANUAL



INVERTER GENERATOR PARALLEL KIT



MODEL NUMBER
100319

SAVE THESE INSTRUCTIONS
Important safety instructions
are included in this manual.

MADE IN CHINA
REV 100319-20160512

12039 Smith Ave.
Santa Fe Springs CA 90670 USA
1-877-338-0999
www.championpowerequipment.com

Have questions or need assistance?

Do not return this product to the store!

WE ARE HERE TO HELP!

Visit our website:

www.championpowerequipment.com

for more info:

- Product Info & Updates
- Tech Bulletins
- Frequently Asked Questions
- Product Registration

– or –

Call our Customer Care Team Toll-Free at:

1-877-338-0999

Parts Ordering:

Mon – Fri 8:30 AM – 5:00 PM (PST/PDT)

Toll Free: 1-877-338-0999

For residents of California:

WARNING: This product contains chemicals known to the State of California to cause cancer or birth defects and other reproductive harm.

*We are always working to improve our products. Therefore, the enclosed product may differ slightly from the image on the cover.

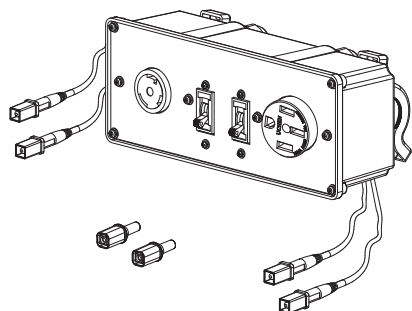

Inverter generator parallel kit

TABLE OF CONTENTS

Introduction	1
Controls and Features	2
Power Panel	2
Operation	3
Paralleling two 2800W+ inverters	3
Paralleling one 2800W+ inverter and one 2000W inverter	3
Specifications	4
Wiring Diagram	4
Parts Diagram	5
Parts List	5

INTRODUCTION

Congratulations on your purchase of a Champion Power Equipment product. Champion Power Equipment and Champion Engine Technology designs, builds, and supports all of our products to strict specifications and guidelines. With proper product knowledge, safe use, and regular maintenance, this product should bring years of satisfying service.

Every effort has been made to ensure the accuracy and completeness of the information in this manual, and we reserve the right to change, alter and/or improve the product and this document at any time without prior notice.

Since CPE/CET highly value how our products are designed, manufactured, operated and are serviced, and also highly value your safety and the safety of others, we would like you to take the time to review this product manual and other product materials thoroughly and be fully aware and knowledgeable of the assembly, operation, dangers and maintenance of the product before use. Fully familiarize yourself, and make sure others who plan on operating the product fully familiarize themselves too, with the proper safety and operation procedures before each use. Please always exercise common sense and always err on the side of caution when operating the product to ensure no accidents, property damage, or injury occurs. We want you to continue to use and be satisfied with your CPE/CET product for years to come.

Record the model and serial numbers as well as date and place of purchase for future reference. Have this information available when ordering parts and when making technical or warranty inquiries.

Champion Power Equipment Support
1-877-338-0999
Model Number
100319
Serial Number
Date of Purchase
Purchase Location

Power Panel

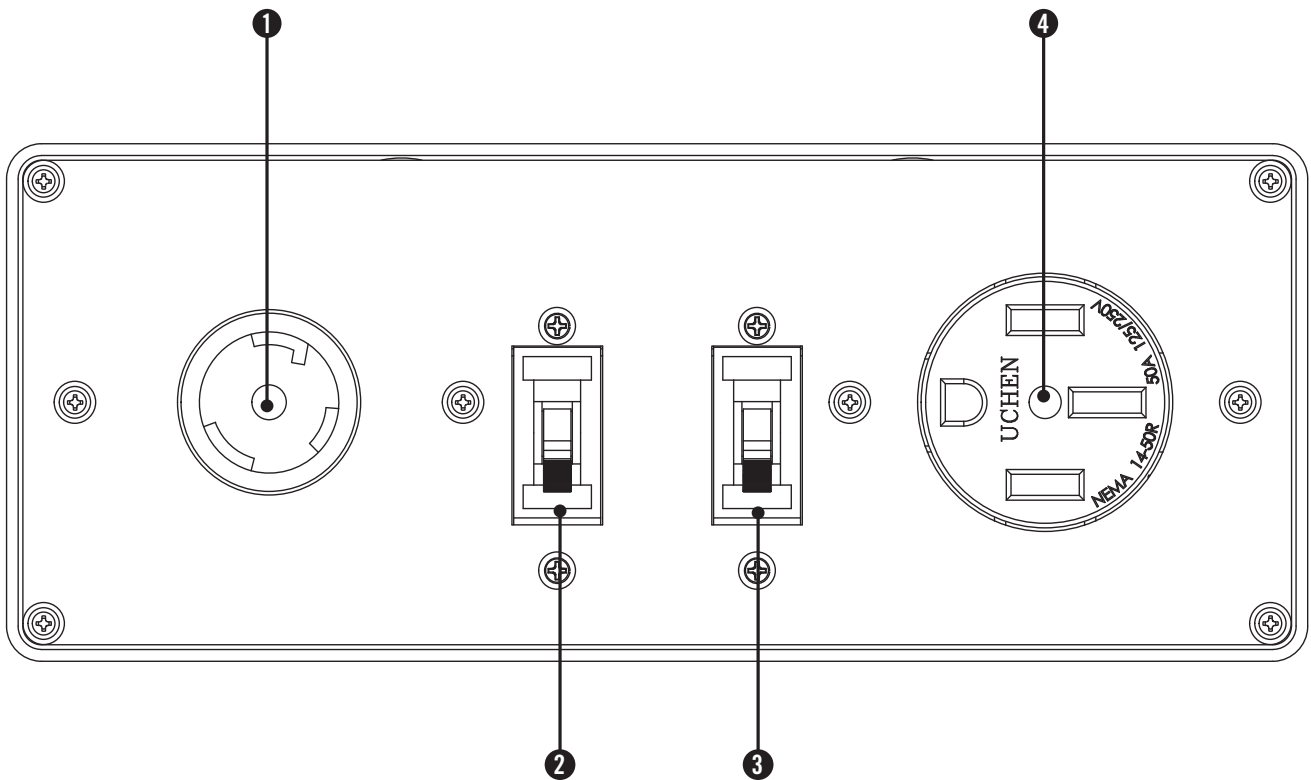

- (1) **120 Volt, 30 Amp Twist-Lock Receptacle** – (Nema L5-30R) This receptacle powers 120 Volt AC, 60 Hz, single phase loads.
- (2) **Circuit Breaker 30 Amp** – Protects against electrical overload.
- (3) **Circuit Breaker 50 Amp** – Protects against electrical overload.
- (4) **120 Volt, 50 Amp Receptacle** (14-50R) – This receptacle powers 120 Volt AC, 60 Hz, single phase loads. 240V AC not available.

 **DANGER**

Generators produces powerful voltage.

DO NOT touch bare wires or receptacles.
 DO NOT use electrical cords that are worn, damaged or frayed.
 DO NOT operate generator in wet weather.
 DO NOT allow children or unqualified persons to operate or service the generator
 Always inspect your parallel kit, outlets, wires, parts prior to use.
 DO NOT use if any part or wire is frayed, exposed, or broken.

OPERATION

This kit is intended for the use with Champion Power Equipment inverters with a least one inverter being 2800W or larger (2800+), and with the ability to parallel. Please refer to your inverter Owner's Manual for safety rules, start up, and shut down procedures, specifications, and troubleshooting.

The total output of this kit will depend on the size of the inverters connected to it. The maximum output of the parallel kit is the total amperage of the circuit breakers.

WARNING

If not spaced apart, the exhaust heat from one unit may discolor or melt the plastic on the other unit.

Paralleling two 2800W+ inverters

1. Inverters to be turned off and all electrical loads disconnected before installing parallel kit.
2. Align the inverters in the same direction in a "V" configuration at a minimum of 18 in. [45 cm] apart.
3. Clamp the parallel kit to the left handle of the inverter on the left of the "V".
4. On each inverter, remove the connector end cap and insert the RED power lead into the RED receptacle and the BLACK power lead into the BLACK receptacle.
5. On each inverter, connect the grounding wire to the grounding terminal on the inverter.
6. Start engine of both inverters according to inverter Owner's Manual. Observe the green output indicator light on both inverter panels. The light will blink during start up and will be solid when loads may be connected.
7. Connect devices to parallel or inverter panels up to the receptacles rated amperage. Never exceed the specified capacity of the receptacle.
8. Follow the instructions in the inverter Owner's Manual for turning off the inverter.

Paralleling one 2800W+ inverter and one 2000W inverter

1. Inverters to be turned off and all electrical loads disconnected before installing parallel kit.
2. Align the inverters in the same direction in a "V" configuration at a minimum of 18 in. [45 cm] apart.
3. Clamp the parallel kit to the left handle of the inverter on the left of the "V".
4. Connect the 2800W+ inverter.
5. Connect the 2000W inverter by removing the adapter connectors from the back of the parallel kit. Remove the connector end cap and insert the RED power lead into the RED adapter connector and then into the RED receptacle and the BLACK power lead into the BLACK adapter connector and then into the BLACK receptacle.
6. Start engine of both inverters according to inverter Owner's Manual. Observe the green output indicator light on both inverter panels. The light will blink during start up and will be solid when loads may be connected.
7. Connect electrical loads to parallel or inverter panels up to the receptacles rated amperage. Never exceed the specified capacity of the receptacle.
8. Follow the instructions in the inverter Owner's Manual for turning off the inverter.

Wiring Diagram

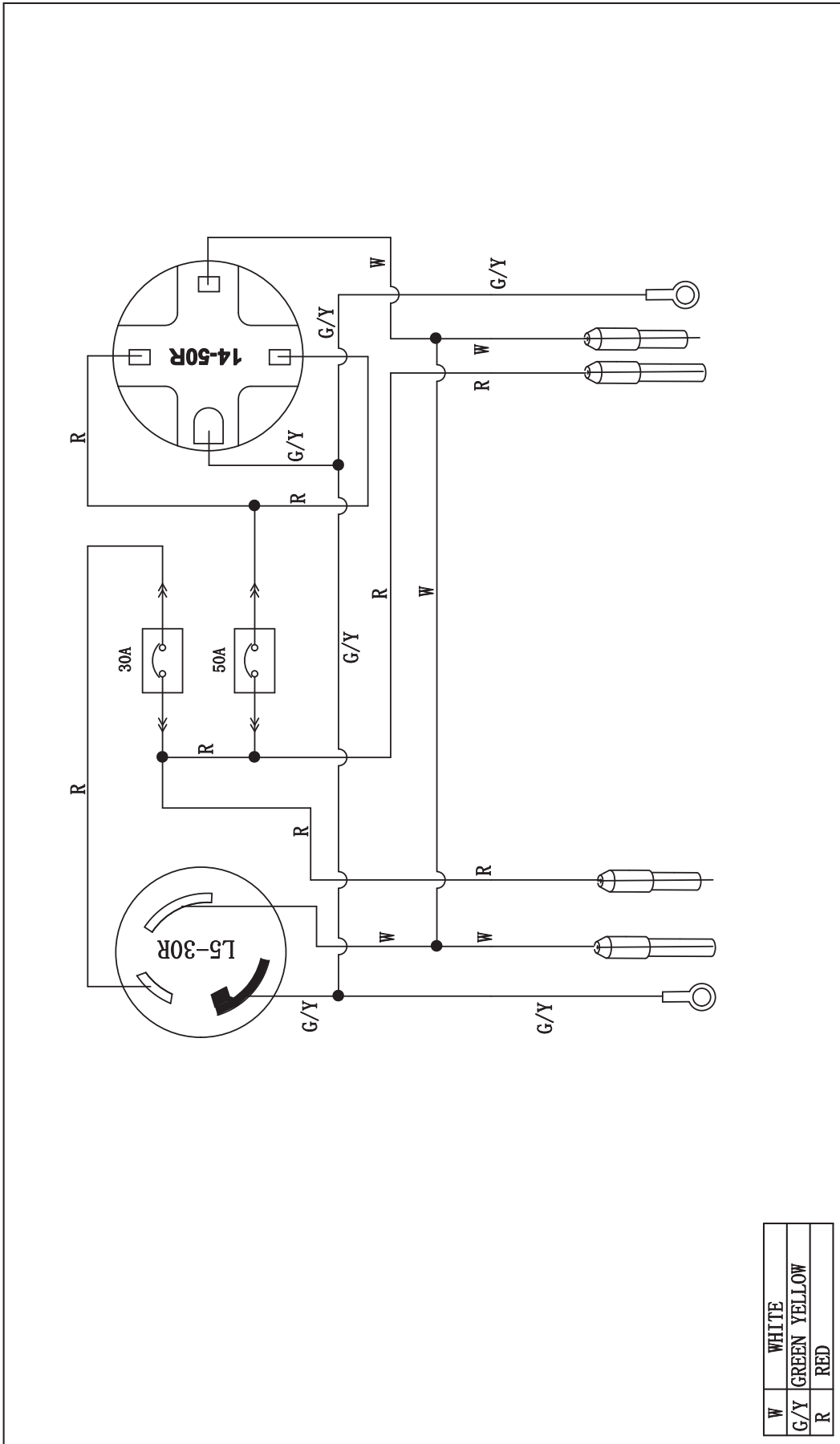

SPECIFICATIONS

Parts Diagram

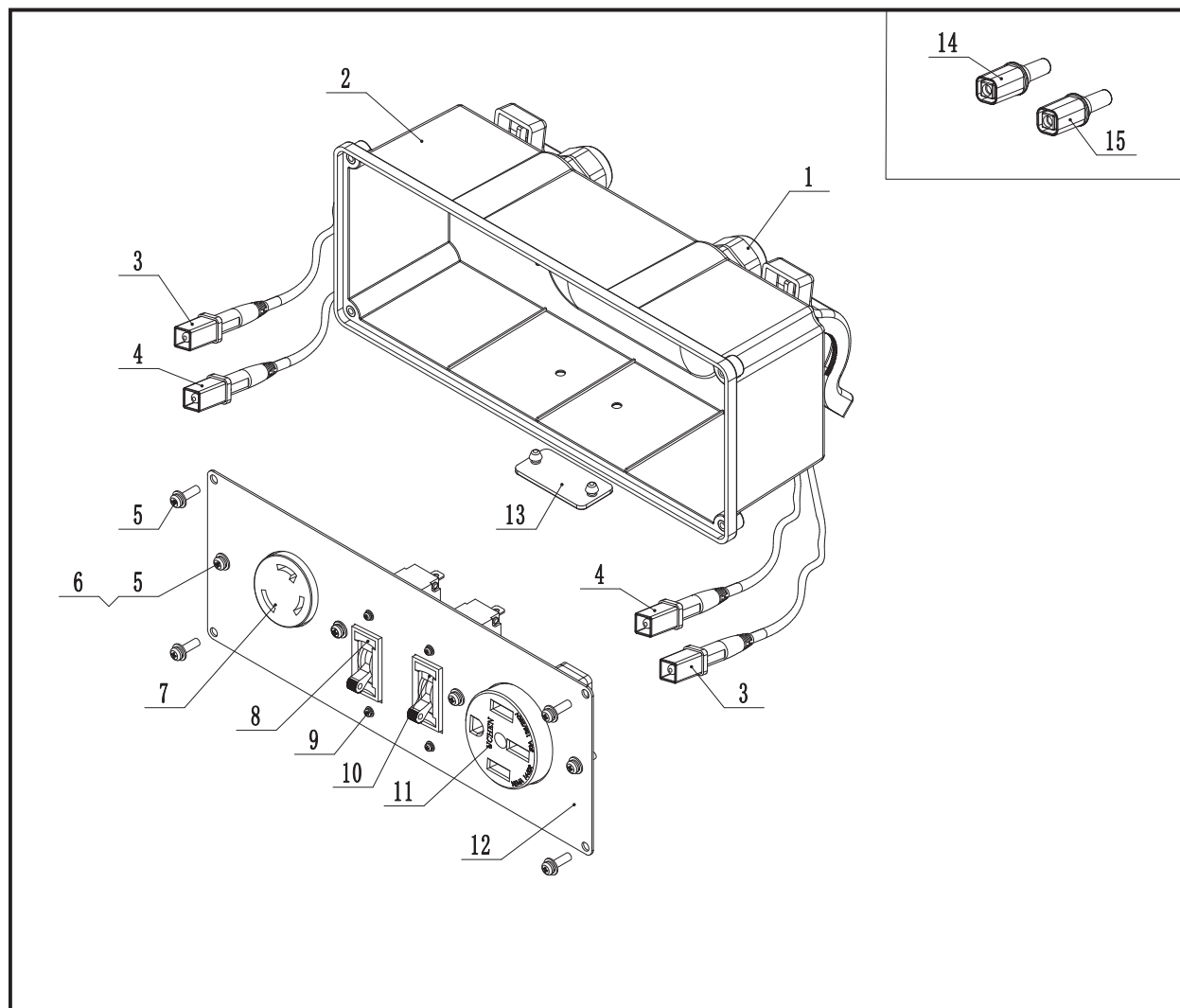

Parts List

#	Part Number	Description	Qty
1	81.210003.00	Plug, Wire	2
2	83.213001.00	Control Box	1
3	83.210006.00.3	Plug, Parallel, Wire 280 mm, Red	2
4	83.210006.01.1	Plug, Parallel, Wire 250 mm, Black	2
5	1.9074.4.0414.1	Screw/Washer Assembly M4x14	8
6	1.6177.1.04.1	Lock Nut M4, Flange	4
7	5.1120.008	Receptacle L5-30R	1
8	5.1230.300	30Amp Circuit Breaker, Flip Lever	1
9	1.9074.4.0306.1	Screw/Washer Assembly M3x6	4

#	Part Number	Description	Qty
10	5.1230.500	50Amp Circuit Breaker, Flip Lever	1
11	5.1120.039	Receptacle 14-50R, CSA	1
12	83.213100.03	Control Panel	1
13	83.213004.00	Rubber Insert	1
14	9.1700.002.1	Adaptor Plug, Parallel, Black	1
15	9.1700.002.3	Adaptor Plug, Parallel, Red	1

WARRANTY

WARRANTY

CHAMPION POWER EQUIPMENT
1 YEAR LIMITED WARRANTY

Warranty Qualifications

Champion Power Equipment (CPE) will register this warranty upon receipt of your Warranty Registration Card and a copy of your sales receipt from one of CPE's retail locations as proof of purchase. Please submit your warranty registration and your proof of purchase within ten (10) days of the date of purchase.

Repair/Replacement Warranty

CPE warrants to the original purchaser that the mechanical and electrical components will be free of defects in material and workmanship for a period of one year (parts and labor) from the original date of purchase and 90 days (parts and labor) for commercial and industrial use. Transportation charges on product submitted for repair or replacement under this warranty are the sole responsibility of the purchaser. This warranty only applies to the original purchaser and is not transferable.

Do Not Return The Unit To The Place Of Purchase

Contact CPE's Technical Service and CPE will troubleshoot any issue via phone or e-mail. If the problem is not corrected by this method, CPE will, at its option, authorize evaluation, repair or replacement of the defective part or component at a CPE Service Center. CPE will provide you with a case number for warranty service. Please keep it for future reference. Repairs or replacements without prior authorization, or at an unauthorized repair facility, will not be covered by this warranty.

Warranty Exclusions

This warranty does not cover the following repairs and equipment:

Normal Wear

Products with mechanical and electrical components need periodic parts and service to perform well. This warranty does not cover repair when normal use has exhausted the life of a part or the equipment as a whole.

Installation, Use and Maintenance

This warranty will not apply to parts and/or labor if the product is deemed to have been misused, neglected, involved in an accident, abused, loaded beyond the product's limits, modified, installed improperly or connected incorrectly to any electrical component. Normal maintenance is not covered by this warranty and is not required to be performed at a facility or by a person authorized by CPE.

Other Exclusions

This warranty excludes:

- Cosmetic defects such as paint, decals, etc.
- Wear items such as filter elements, o-rings, etc.
- Accessory parts such as starting batteries, and storage covers.
- Failures due to acts of God and other force majeure events beyond the manufacturer's control.
- Problems caused by parts that are not original Champion Power Equipment parts.

Limits of Implied Warranty and Consequential Damage

Champion Power Equipment disclaims any obligation to cover any loss of time, use of this product, freight, or any incidental or consequential claim by anyone from using this product. THIS WARRANTY IS IN LIEU OF ALL OTHER WARRANTIES, EXPRESS OR IMPLIED, INCLUDING WARRANTIES OF MERCHANTABILITY OR FITNESS FOR A PARTICULAR PURPOSE.

A unit provided as an exchange will be subject to the warranty of the original unit. The length of the warranty governing the exchanged unit will remain calculated by reference to the purchase date of the original unit.

This warranty gives you certain legal rights which may change from state to state or province to province. Your state or province may also have other rights you may be entitled to that are not listed within this warranty.

Contact Information

Address

Champion Power Equipment, Inc.
Customer Service
12039 Smith Ave.
Santa Fe Springs, CA 90670 USA
www.championpowerequipment.com

Customer Service

Mon – Fri 8:30 AM – 5:00 PM (PST/PDT)
Toll Free: 1-877-338-0999
info@championpowerequipment.com
Fax no.: 1-562-236-9429

Technical Service

Mon – Fri 8:30 AM – 5:00 PM (PST/PDT)
Toll Free: 1-877-338-0999
tech@championpowerequipment.com
24/7 Tech Support: 1-562-204-1188