

INDOOR/OUTDOOR PRODUCTS
KEROSENE PORTABLE
FORCED AIR HEATERS
“USER’S MANUAL AND
OPERATING INSTRUCTIONS”

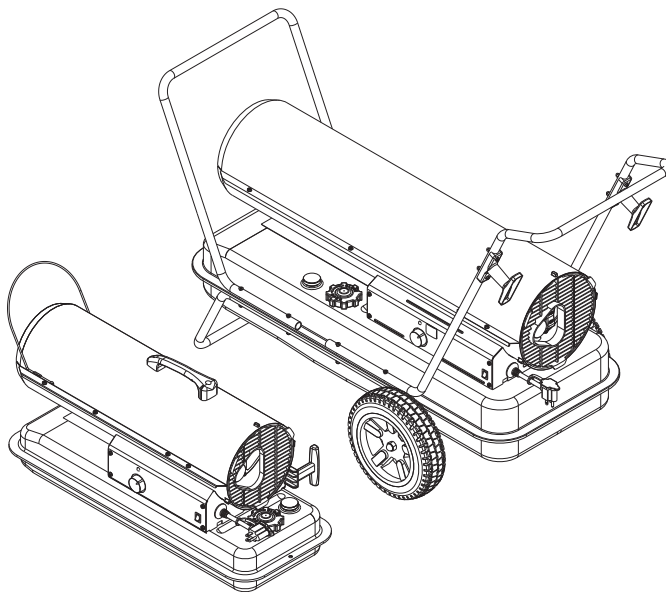

COMPLIES WITH UL733 AND
ANSI A10.10-1998
CAN/CSA/B140.0-03 AND CSA
B140.8-1967

MODEL : KFA80C, KFA135C, KFA220C

Before the first use of this heater, please read this USER’S MANUAL very carefully. This USER’S MANUAL has been designed to instruct you as to the proper manner in which to assemble, maintain, store, and most importantly, how to operate the heater in a safe and efficient manner. Please keep this manual for future reference.

CONSUMER : Retain this manual for future reference.

Questions, problems, missing parts? Before returning to your retailer, call our customer service department at 877-447-4768 8:30 a.m. - 4:30 pm CST, Monday - Friday.
or email us at customerservice@ghpgroupinc.com

**NEVER LEAVE THE HEATER
UNATTENDED WHILE BURNING!**

⚠ DANGER: IMPROPER USE OF THIS HEATER CAN RESULT IN SERIOUS INJURY OR DEATH FROM BURNS, FIRE, EXPLOSION, ELECTRICAL SHOCK AND/OR CARBON MONOXIDE POISONING.

⚠ WARNINGS:

1. RISK OF INDOOR AIR POLLUTION!

- Use this heater only in well ventilated areas. Provide at least a three-square foot (2,800 sq. cm.) opening of fresh outside air for each 100,000 BTU/hr. of heater rating.
- People with breathing problems should consult a physician before using the heater.
- **Carbon monoxide poisoning:** Early signs of carbon monoxide poisoning resemble the flu, with headaches, dizziness and/or nausea. If you have these signs, the heater may not be working properly.
Get fresh air at once! Have the heater serviced. Some people are more affected by carbon monoxide than others. These include pregnant women, persons with heart or lung disease or anemia, those under the influence of alcohol, or those at high altitudes.
- Never use this heater in living or sleeping areas.

2. RISK OF BURNS/FIRE/EXPLOSION!

- **NEVER** use any fuel other than 1-K kerosene, #1/#2 diesel/fuel oil, JET A or JP-8 fuels in this heater.
- **NEVER** use fuel such as gasoline, benzene, paint thinners or other oil compounds in this heater.
(RISK OF FIRE OR EXPLOSION)
- **NEVER** use this heater where flammable vapors may be present.
- **NEVER** refill the heaters fuel tank while heater is operating or is still hot.

⚠ CAUTION : Hot while in operation. Do not touch. Keep children, clothing and combustibles away from heater.

Minimum Clearances: Outlet: 8 feet (250cm) / Sides, top and rear: 4 feet (125cm)

- **NEVER** block air inlet (rear) or air outlet (front) of heater.
- **NEVER** use duct work in front or behind of heater.
- **NEVER** move, handle, service a hot, operating or plugged in heater.
- **NEVER** transport heater with fuel in it's tank.
- When used with an optional thermostat or if equipped with a thermostat heater may start at any time.
- **ALWAYS** locate heater on a stable and level surface.
- **ALWAYS** keep children and animals away from heater.
- Bulk fuel storage should be a minimum of 25 ft. from heaters, torches, portable generators or other sources of ignition. All fuel storage should be in accordance with federal, state or local authorities having jurisdiction.

3. RISK OF ELECTRIC SHOCK!

- Use only the electrical power (voltage and frequency) specified on the model plate of the heater.
- Use only a three-prong, grounded outlet and extension cord.
- **ALWAYS** install the heater so that it is not directly exposed to water spray, rain, dripping water or wind.
- **ALWAYS** unplug the heater when not in use.

PROPOSITION 65 WARNING: Fuels used in gas, wood-burning or oil fired appliances, and the products of combustion of such fuels, contain chemicals known to the State of California to cause cancer, birth defects and other reproductive harm.

MASSACHUSETTS RESIDENTS: Massachusetts state law prohibits the use of this heater in any building which is used in whole or in part for human habitation. Use of this heating device in Massachusetts requires local fire dept. permit (M.E.L.C. 148, Section 10A.)

CANADIAN RESIDENTS: Use of this heater shall be in accordance with authorities having jurisdiction and CSA Standard B139.

NEW YORK CITY RESIDENTS: For use only at construction sites in accordance with applicable NYC codes under NYC FD certificate of approval # 5034 and 5037.

**NEVER LEAVE THE HEATER
UNATTENDED WHILE BURNING!**

CONTENTS OF USER'S MANUAL

<u>ITEM</u>	<u>PAGE #</u>
PRECAUTIONS - SAFETY GUIDE	1
1. INTRODUCTION	2
2. FEATURES	2
3. UNPACKING AND ASSEMBLY	4
4. FUELS	6
5. OVERVIEW OF HEATER DESIGN	7
6. FUELING YOUR HEATER	8
7. OPERATION	8
8. LONG TERM STORAGE OF YOUR HEATER	9
9. MAINTENANCE	10
10. REPLACING FUSE	14
11. TROUBLE SHOOTING GUIDE	15
12. WIRING DIAGRAM	16
13. SPECIFICATIONS	17
14. EXPLODED PARTS DRAWING	18&21
15. PARTS LIST	19,20&22,23

1. INTRODUCTION

Please read this USER'S MANUAL carefully. It will show you how to assemble, maintain, and operate the heater safely and efficiently to obtain full benefits from its many built-in features.

2. FEATURES

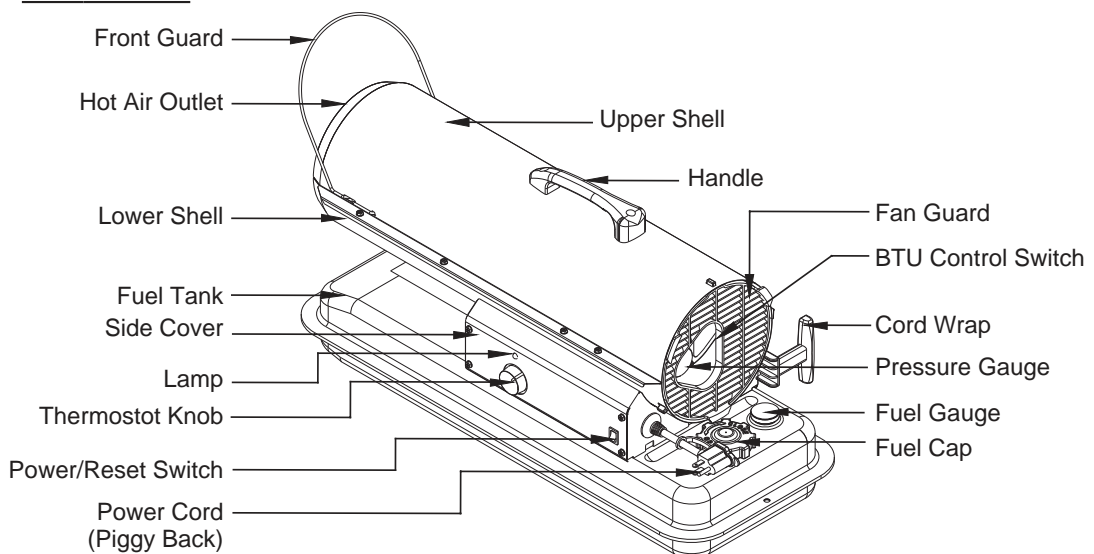

Figure 1. KFA80C MODEL

**NEVER LEAVE THE HEATER
UNATTENDED WHILE BURNING!**

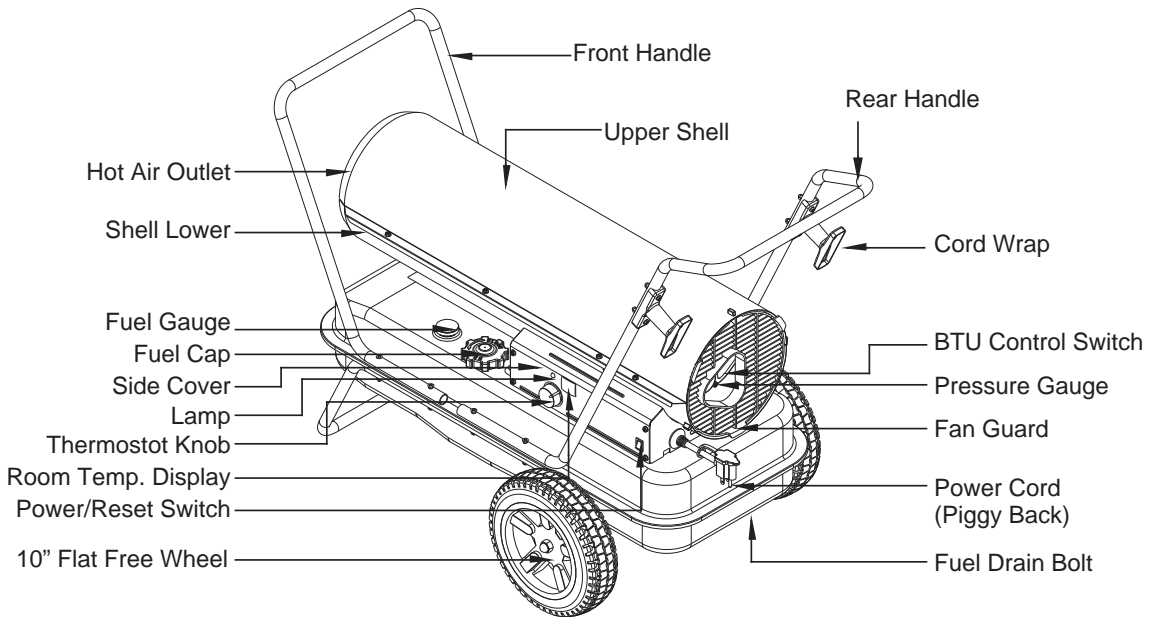

Figure 2. KFA135C MODEL

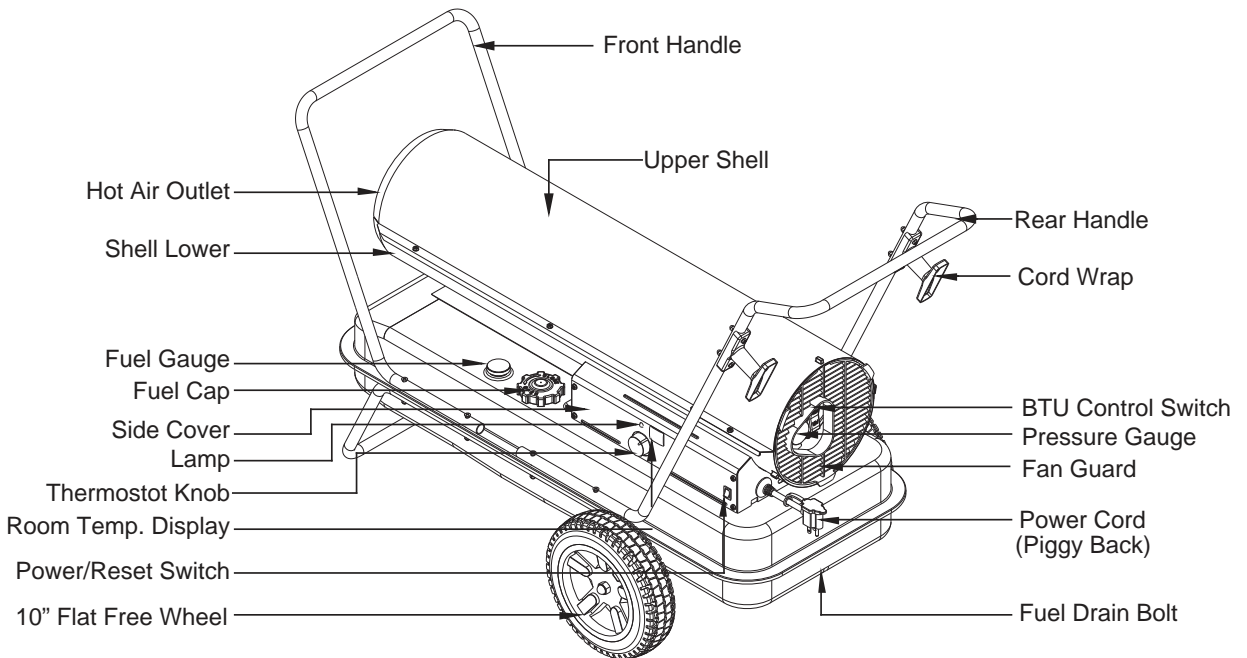

Figure 3. KFA220C MODEL

**NEVER LEAVE THE HEATER
UNATTENDED WHILE BURNING!**

3. UNPACKING AND ASSEMBLY

1. REMOVE THE HEATER AND ALL PACKING MATERIALS FROM THE BOX. (Fig. 4 and 5)

NOTE : Save the shipping carton and packing materials for future storage.

	KFA80C	KFA135C	KFA220C
Wheel Support Frame	No	Yes	Yes
Wheel	No	Yes	Yes
Threaded Axle	No	Yes	Yes
Front Handle	No	Yes	Yes
Rear Handle	No	Yes	Yes
Handle	Yes	No	No
Cord Wrap	Yes	Yes	Yes
Hardware kit : HW-KFA1016	No	Yes	Yes

Figure 4. KFA80C MODEL

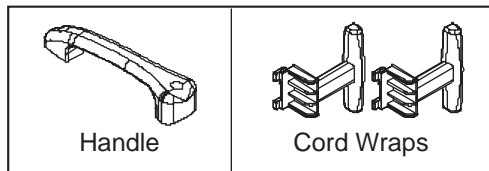
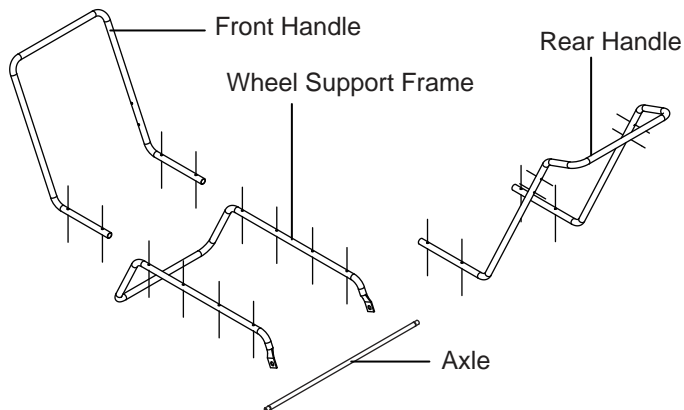
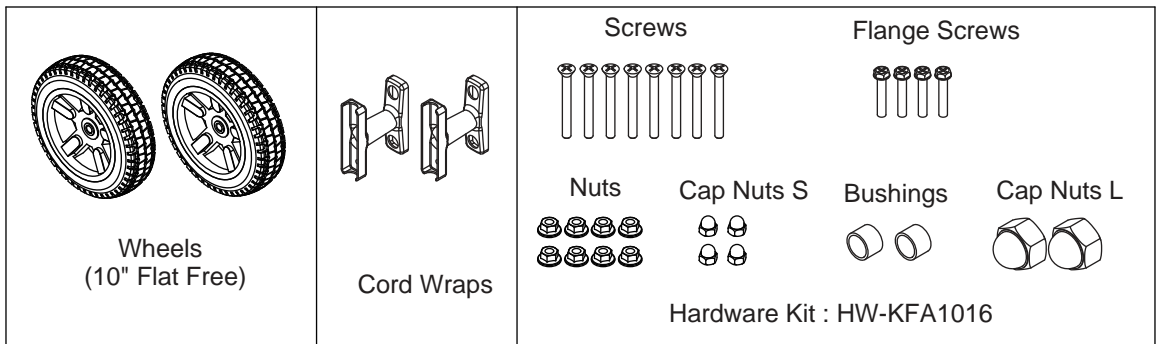

Figure 5. KFA135C/ KFA220C MODELS



**NEVER LEAVE THE HEATER
UNATTENDED WHILE BURNING!**

2. ASSEMBLY

For KFA80C Model only
(Assembly time for this product is 3 minutes)

Tools Required

- Medium Phillips Screwdriver.
- 1) Lift front guard for arrow direction and make sure that guard's wedged portion fits into the slit hole on the upper housing.
 - 2) Remove the pre-assembled screws on the shell upper and side cover.
 - 3) Align the holes in the upper housing with two mounting holes on the handle as shown in Figure 6.
 - 4) Secure handle with the screws removed.
 - 5) Insert card wrap into the rectangle holes on the supporter and align the hole on the cord wrap with the mounting hole on the side cover as shown in Figure 6.
 - 6) Secure cord wrap with the screws removed.

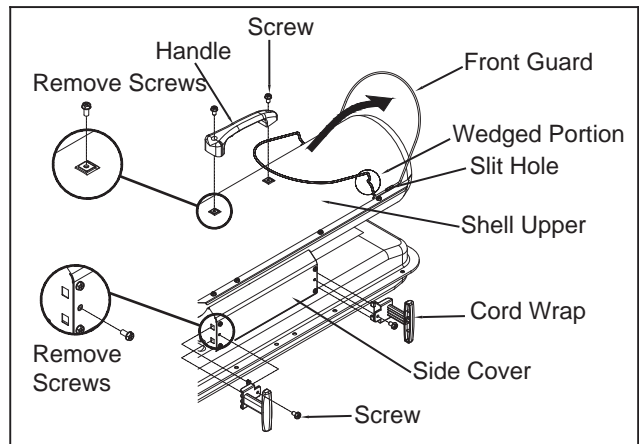

Figure 6. Assembling Handle & Cord Wrap

For KFA135C/220C Models only (Assembly time for this product is 10 minutes)

Tools Required

- Medium Phillips Screwdriver.
- 3/4 inch socket or adjustable wrench

Assembling Handle & Wheel and Cord Wrap

- 1) Slide threaded axle through the rear section of the wheel support frame.
- 2) Slide one axle bushing on to each side of the axle. Slide one wheel on to each side of the axle. Attach one cap nut on to each side of the threaded axle and tighten well.
- 3) Place heater on wheel support frame. Align the holes on fuel tank flange with holes on wheel support frame.
- 4) Position the Handles on top of fuel tank flange. Insert screws through handles, fuel tank flange and wheel support frames as shown in Figure 8 and attach nut finger tight after each screw is inserted.
- 5) Align the hole on the handles with the mounting hole on the Cord Wrap. Insert Screws through Cord Wrap, handles and attach nut finger tight after each screw is inserted.
- 6) After all screws are inserted, tighten nuts firmly.

**NEVER LEAVE THE HEATER
UNATTENDED WHILE BURNING!**

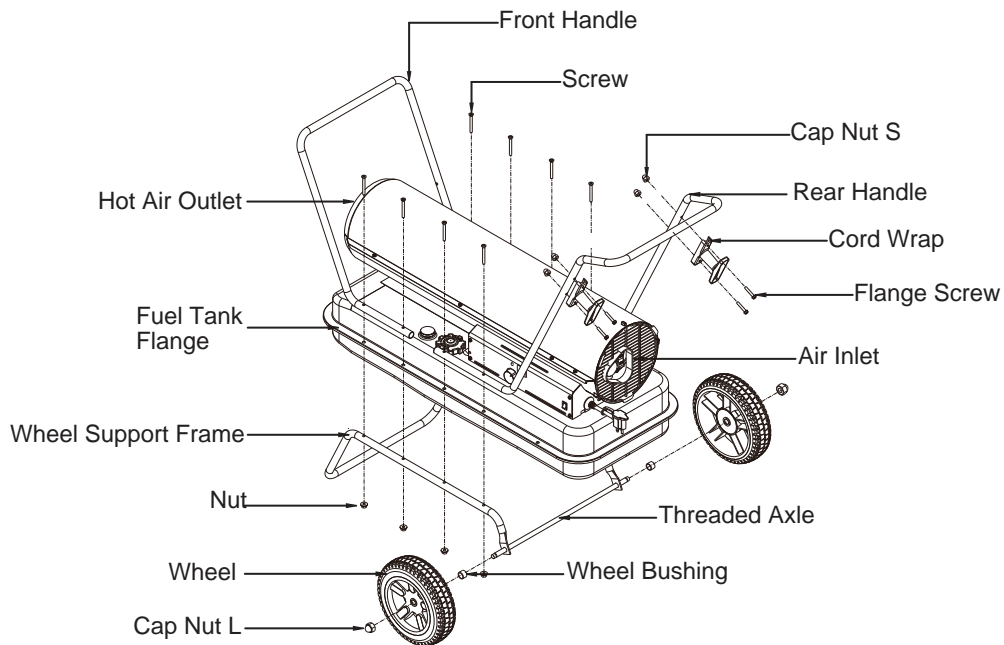

Figure 7. Assembling Handle, Wheel and Cord wrap

⚠ CAUTION : DO NOT OPERATE heater without support frame assembled to tank.

NOTE : Heater should be inspected before each use, and at least annually by a qualified service person.

4. FUELS

For optimal performance of this heater, it is strongly suggested that 1-K kerosene be used. 1-K kerosene has been refined to virtually eliminate contaminants, such as sulphur. Which can cause a rotten egg odor during the operation of the heater. However, #1/#2 diesel/fuel oil, JET A or JP-8 fuels may also be used if 1-K kerosene is not available. Be advised that these fuels do not burn as clean as 1-K kerosene, and care should be taken to provide more fresh air ventilation to accommodate any added contaminants that may be added to the heated space. #2 diesel/fuel oil heavier than 1-K kerosene in extreme cold temperatures without nontoxic anti-icer additives will not ignite properly.

KEROSENE SHOULD ONLY BE STORED IN A BLUE CONTAINER THAT IS CLEARLY MARKED “KEROSENE”. NEVER STORE KEROSENE IN A RED CONTAINER.

Red containers are associated with gasoline.

NEVER store kerosene in the living space. Kerosene should be stored in a well ventilated place outside the living area.

NEVER use any fuel other than 1-K kerosene (#1/#2 diesel/fuel oil, JET A or JP-8 fuels are acceptable substitutes)

NEVER use fuel such as gasoline, benzene, alcohol, white gas, camp stove fuel, paint thinners, or other oil compounds in this heater. These are volatile fuels that can cause an explosion or uncontrolled flames.

NEVER store kerosene in direct sunlight or near a source of heat.

NEVER use kerosene that has been stored from one season to the next. Kerosene deteriorates over time.

“OLD KEROSENE” WILL NOT BURN PROPERLY IN THIS HEATER.

**NEVER LEAVE THE HEATER
UNATTENDED WHILE BURNING!**

5. OVERVIEW OF HEATERS DESIGN

Fuel System : This heater is equipped with an electric air pump that forces air through the air line connected to the fuel intake and then through a nozzle in the burner head. When the air passes in front of the fuel intake it causes fuel to rise from the tank and into the burner nozzle. This fuel and air mixture is then sprayed into the combustion chamber in a fine mist.

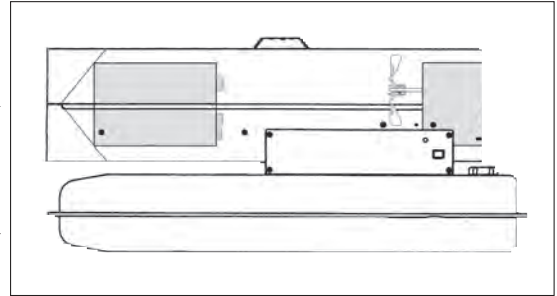

“Sure Fire Ignition” : The electronic ignitor sends voltage to a specially designed spark plug. The spark plug ignites the fuel and air mixture described above.

The Air System : The heavy duty motor turns a fan that forces air into and around the combustion chamber. Here the air is heated and then forced out the front of the heater.

The Safety System :

A. Temperature Limit Control : This heater is equipped with a Temperature Limit Control designed to turn off the heater should the internal temperature rise to an unsafe level. If this device activates and turns your heater off it may require service.

MODELS	Internal Shut-Off Temp. Plus/Minus 10 Degrees	Reset Temperature Plus/Minus 10 Degrees
KFA80C	158°F/70°C	104°F/40°C
KFA135C	158°F/70°C	104°F/40°C
KFA220C	194°F/90°C	140°F/60°C

Once the temperature falls below the reset temperature you will be able to start your heater.

B. Electrical System Protection : This heaters electrical system is protected by a fuse mounted to the PCB assembly that protects it and other electrical components from damage. If your heater fails to operate check this fuse first and replace as needed.

FUSE TYPE:	All Models	125 volt / 8 amps
-------------------	------------	-------------------

C. Flame-Out Sensor : Utilizes a photocell to monitor the flame in burn chamber during normal operation. It will cause the heater to shut-off should the burner flame extinguish.

**NEVER LEAVE THE HEATER
UNATTENDED WHILE BURNING!**

6. FUELING YOUR HEATER

**NEVER FILL THE HEATER FUEL TANK IN THE LIVING SPACE : FILL THE TANK OUTDOORS.
DO NOT OVERFILL YOUR HEATER AND BE SURE HEATER IS LEVELED.**

IMPORTANT NOTICE REGARDING FIRST IGNITION OF HEATER :

The first time you light the heater, it should be done outdoors. This allows the oils, etc. used in manufacturing the heater to burn off outside.

⚠ WARNING!! : NEVER REFILL HEATER FUEL TANK WHEN HEATER IS OPERATING OR STILL HOT.

7. OPERATION

A.) VENTILATION

RISK OF INDOOR AIR POLLUTION/USE HEATER ONLY IN WELL VENTILATED AREAS.

Provide a fresh air opening of at least three square feet (2,800 sq. cm) for each 100,000 BTU/Hr. rating. Provide extra fresh air if more heaters are being used.

Example :

A KFA220C heater requires one of the following:

- a two-car garage door raised six inches (15.24 cm)
- a single-car garage door raised nine inches (22.86 cm)
- two, thirty-inch (76.20 cm) windows raised fifteen inches (38.1 cm)

B.) OPERATION

TO START HEATER

1. Fill fuel tank with fuel.

NOTE : Kerosene is recommended when the temperature drops below 0°F(-18°C) to prevent ignition delay or failure.

2. Attach fuel cap.

3. Plug power cord of heater into three-prong, grounded extension cord. Extension cord must be at least six feet long.

Extension Cord Wire Size Requirements

- 6 to 100 feet (1.8 to 30.5 meters) long, use 16 AWG conductor.
- 101 to 200 feet (30.8 to 61 meters) long, use 14 AWG conductor.

4. Turn “THERMOSTAT CONTROL knob” to desired setting (setting range : 40°F ~ 110°F)

5. Push “BTU control Switch” to “High” level. (See Figure 8.)

6. Push Power Switch to “ON” position, Power Indicator Lamp will light and heater will start.

7. After startup, push “BTU control switch” to desired level “High or Low”

NOTE : Room Temperature display explanations are as follows: (KFA135C/220C Models only)

- **When the room temperature is less 0°F, the LED display will show “Lo”**
- **When room temp is between 0°F and 99°F, the number shown on the display is the current room temperature.**
- **When room temperature is greater than 99°F, the LED display will show “Hi”**

If heater does not start, the thermostat setting may be too low, turn “thermostat Control Knob” to higher position to start heater. If heater still does not start, turn power switch to “OFF” and then to “ON” position. If heater still does not start, see Troubleshooting Guide on page15.

NOTE : User can select to operate the heater on two different BTU levels(High or Low).

To stabilize heater and prevent ignition delay, select BTU level after turning the heater on, or while it is in operation by pushing the BTU control switch. If the heater started at low BTU level in cold weather or low fuel tank, ignition failure can occur.

NOTE : In cold weather, ignition may be improved by holding a finger over the end of the relief valve or block fanguard in half with newspaper etc. until the heater ignites.

NEVER LEAVE THE HEATER UNATTENDED WHILE BURNING!

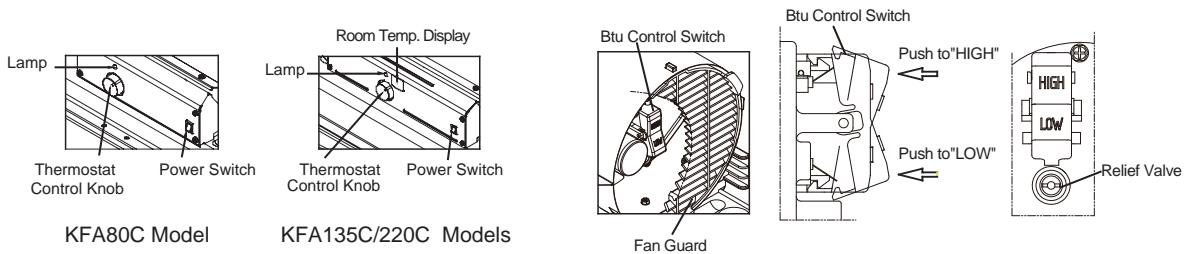

Figure 8. Controls for All Models

NOTICE : The major electrical components of this heater are protected by a safety fuse mounted to the PCBboard. If your heater fails to start, check this fuse first and replace as necessary. You should also check your power source to insure that proper voltage and frequency are being supplied to the heater.

TO STOP HEATER

1. Turn switch to “OFF” and unplug power cord.

TO RESTART HEATER

1. Wait 10 seconds after stopping heater.
2. Repeat steps under to start heater.

PIGGYBACK POWER CORD

⚠ WARNING : SHOCK HAZARD!

- Always cover electric outlet when not in use.
- Don’t plug and use a appliance more than 120V/60Hz 5A current in this outlet.

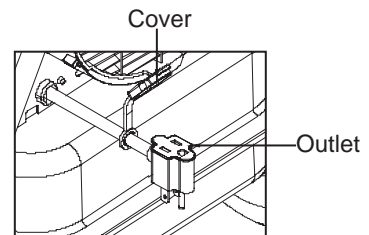

Figure 9. PiggyBack Power Cord

8. LONG TERM STORAGE OF YOUR HEATER

FUEL TANK DRAIN

1. Drain fuel tank through fuel cap opening.
(For KFA80C Model Only)
2. Remove fuel drain bolt from rear bottom side of fuel tank using 3/4” socket or adjustable wrench and drain.
(For KFA135C /220C Models Only. See Figure 10)
3. Using a small amount of kerosene, swirl and rinse the inside of the tank.
NEVER mix water with the kerosene as it will cause rust inside the tank.
Pour the kerosene out making sure that you remove it all.
IMPORTANT : Do not store kerosene over summer months for use during next heating season.

Using old fuel could damage heater.

4. Reinstall fuel cap. Properly dispose of old and dirty fuel.
(For KFA80C Models Only)
5. Reinstall fuel drain bolt to Fuel tank and tighten firmly using 3/4” socket or adjustable wrench. (For KFA135C /220C Models Only. See Figure 10)

IMPORTANT : Before reinstalling the fuel drain bolt, make sure the seal is on the bolt. If the seal is not used the bolt cannot be installed correctly and the fuel tank will leak.

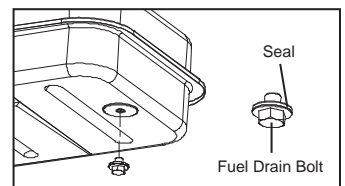

Figure 10. Fuel Drain Bolt

6. Store heater in dry well ventilated area. Make sure storage place is free of dust and corrosive fumes.
7. Store the heater in the original box with the original packing material and keep the USER’S MANUAL with the heater.

**NEVER LEAVE THE HEATER
UNATTENDED WHILE BURNING!**

9. MAINTENANCE

⚠ WARNING!! : NEVER SERVICE HEATER WHILE IT IS PLUGGED IN OR WHILE HOT!

USE ORIGINAL EQUIPMENT REPLACEMENT PARTS. Use of third party or other alternate components will void warranty and may cause unsafe operating conditions.

A.) FUEL TANK

FLUSH EVERY 200 HOURS OF OPERATION OR AS NEEDED (SEE STORAGE, PAGE 9)

B.) AIR INTAKE FILTER

WASH AND DRY WITH SOAP AND WATER EVERY 500 HOURS OF OPERATION OR AS NEEDED.

- Remove screws along each side of heater using medium phillips screwdriver.
- Lift upper shell off.
- Remove fan guard.
- Wash or replace air intake filter.
- Reinstall fan guard and upper shell.

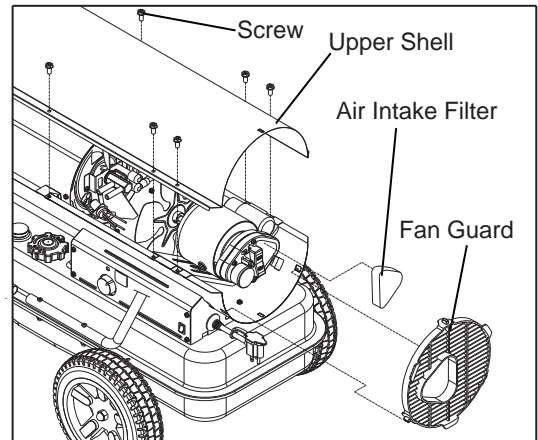

Figure 11. Air Intake Filter Access

C.) AIR OUTPUT FILTER, LINT FILTER

REPLACE EVERY 500 HOURS OF OPERATION OR ONCE A YEAR.

- Remove upper shell and fan guard (See Air Intake Filter).
- Turn Air pressure gauge counter-clock wise and remove.
- Remove end filter cover screws using medium phillips screwdriver.
- Remove end filter cover.
- Replace air output and lint filter.
- Reinstall end filter cover and air pressure gauge.
- Reinstall fan guard and upper shell.

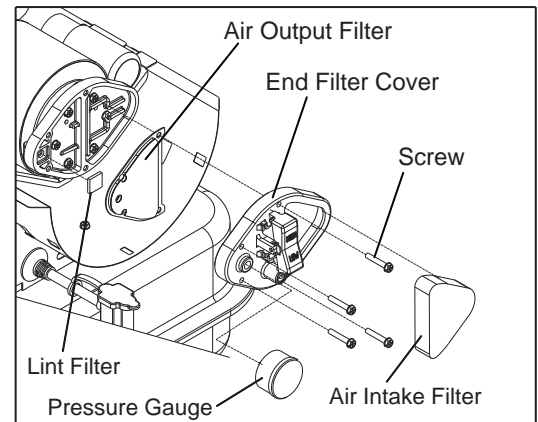

Figure 12. Air Output Filter Access

D.) FAN BLADES

CLEAN EVERY SEASON OR AS NEEDED.

- Remove upper shell (See Air Intake Filter).
- Use M6 allen wrench to loosen set screw which holds fan blade to motor shaft.
- Slip fan blade off motor shaft.
- Clean fan blade using a soft cloth moistened with kerosene or solvent.
- Dry fan blade thoroughly.
- Reinstall fan blade on motor shaft. Place fan blade hub flush with end of motor shaft.
- Place set screw on flat of shaft. Tighten set screw firmly (40-50 inch-pounds/4.5-5.6 N-m).
- Reinstall upper shell.

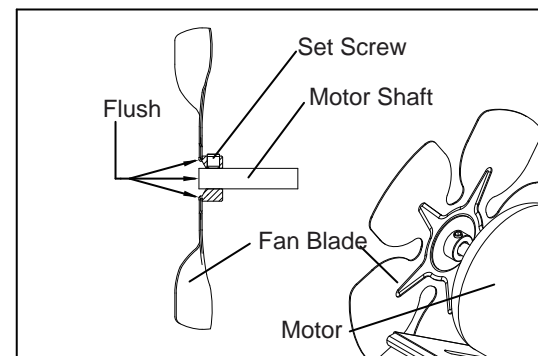

Figure 13. Fan Assembly

NEVER LEAVE THE HEATER UNATTENDED WHILE BURNING!

E.) NOZZLE

REMOVE DIRT IN NOZZLE AS NEEDED (SEE PAGE 16).

(For KFA80C/135C Models Only)

- Remove upper shell (See page 10).
- Remove fan blade (See page 10).
- Remove fuel and air line hoses from nozzle adaptor.
- Remove ignitor wire from spark plug.
- Remove spark plug from nozzle adaptor using medium phillips screwdriver.
- Turn nozzle adaptor 1/9 turn(40°) to counter clock wise and pull toward motor to remove. (See Figure 14)
- Place plastic hex-body into vise and lightly tighten.
- Carefully remove nozzle from nozzle adaptor using 5/8" socket wrench.
- Blow compressed air through face of nozzle. (this will remove any dirt in nozzle)
- Reinstall nozzle into nozzle adaptor until nozzle seats. Tighten 1/3 turn more using 5/8" socket wrench. (40~45 inch-pounds)
- Reinstall nozzle adaptor to bracket adaptor.
- Reinstall spark plug to nozzle adaptor.
- Attach ignitor wire to spark plug.
- Attach fuel and air line hoses to nozzle adaptor.
- Reinstall fan blade and upper shell.

(For KFA220C Model Only)

- Remove upper shell (See page 10).
- Remove fan (See page 10).
- Remove fuel and air line hoses from nozzle adaptor.
- Remove ignitor wire from spark plug.
- Remove spark plug from nozzle adaptor using medium phillips screwdriver.
- Turn nozzle adaptor 1/8 turn (45°) to counter clock wise and pull toward motor to remove. (See Figure 15)
- Place plastic hex-body into vise and lightly tighten.
- Carefully remove nozzle from nozzle adaptor using 5/8" socket wrench.
- Blow compressed air through face of nozzle. (this will remove any dirt in nozzle)
- Reinstall nozzle into nozzle adaptor until nozzle seats. Tighten 1/3 turn more using 5/8" socket wrench (40~45 inch-pounds)
- Reinstall nozzle adaptor to burner bracket
- Reinstall spark plug to nozzle adaptor.
- Attach ignitor wire to spark plug.
- Attach fuel and air line hoses to nozzle adaptor.
- Reinstall fan blade and upper shell.

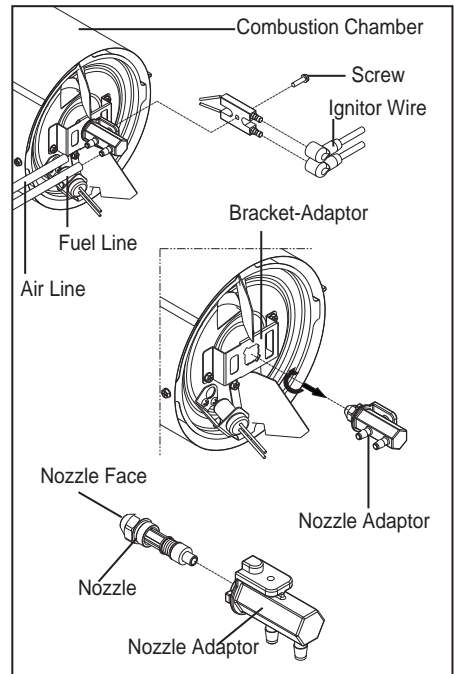

Figure 14. Nozzle Replacement

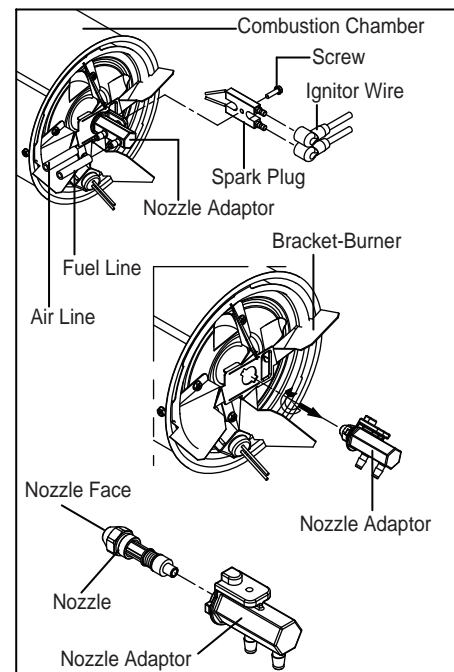

Figure 15. Nozzle Replacement

NEVER LEAVE THE HEATER UNATTENDED WHILE BURNING!

F.) SPARK PLUG

CLEAN AND REGAP EVERY 600 HOURS OPERATION OR REPLACE AS NEEDED.

(For KFA80C/135C Models Only)

- Remove upper shell (See page 10).
 - Remove fan (See page 10).
 - Remove ignitor wire from spark plug.
 - Remove spark plug from nozzle adaptor using medium phillips screwdriver.
 - Clean and regap spark plug electrodes to 3.5mm gap. (0.138")
 - Reinstall spark plug to nozzle adaptor.
 - Attach ignitor wire to spark plug.
 - Reinstall fan and upper shell.
- (For KFA220C Model Only)
- Remove upper shell (See page 10).
 - Remove fan (See page 10).
 - Remove ignitor wire from nozzle adaptor.
 - Remove spark plug from nozzle adaptor using medium phillips screwdriver.
 - Clean and regap spark plug electrodes to 3.5mm gap. (0.138")
 - ReInstall spark plug to nozzle adaptor.
 - Attach ignitor wire to spark plug.
 - Reinstall fan and upper shell.

G.) PHOTOCELL

CLEAN PHOTOCELL ANNUALLY OR AS NEEDED.

- Remove upper shell (See page 10).
- Remove fan (See page 10).
- Remove photocell from it's mounting.
- Clean photocell lens with cotton swab.

TO REPLACE:

- Remove side cover screws using medium phillips screwdriver.
- Disconnect switch wires from power switch and remove side cover.
- Disconnect wires from circuit board and remove photocell.
- Install new photocell and connect wires to circuit board.
- Replace switch wires to power switch and side cover.
- Replace fan and upper shell.

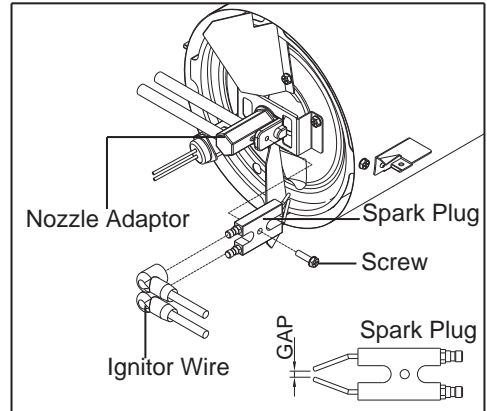

Figure 16. Spark Plug Regap

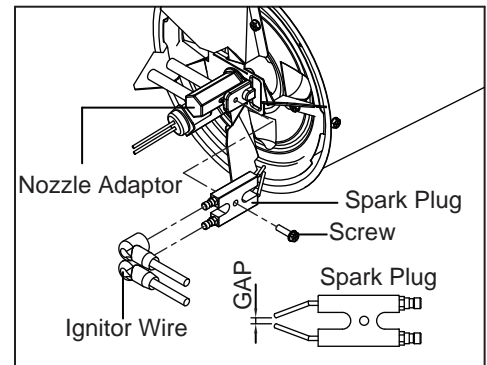

Figure 17. Spark Plug Regap

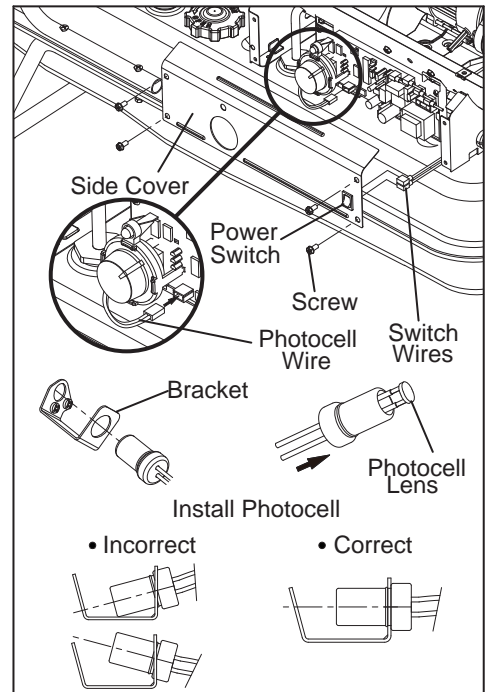

Figure 18. Photocell Replacement

NEVER LEAVE THE HEATER UNATTENDED WHILE BURNING!

H.) FUEL FILTER

CLEAN OR REPLACE TWICE A HEATING SEASON OR AS NEED.

- Remove side cover screws using medium phillips screwdriver.
- Disconnect switch wires from power switch and remove side cover.
- Pull fuel line off fuel filter neck.
- Turn fuel filter 90° to counter clockwise and pull to remove (KFA80C Model only).
- Turn fuel filter 90° to clockwise and pull to remove (KFA135C/220C Models only).
- Wash fuel filter with clean fuel and replace in tank.
- Attach fuel line to fuel filter neck.
- Replace switch wires to power switch.
- Reinstall side cover.

I.) PUMP PRESSURE ADJUSTMENT

NOTE: If the pump pressure needs to be adjusted, make sure the heater is running on the HIGH BTU setting.

- Push the BTU control switch to HIGH .
(See Operation on page 8)
- Start heater (See Operation, page 8)
Allow motor to reach full speed
- Adjust pressure (Using a flat blade screwdriver)
Turn relief valve to clockwise to increase pressure.
Turn relief valve to counter clockwise to decrease pressure.
- Stop heater (See Operation, page 8)

MODEL	Pump Pressure	
	High BTU level	Low BTU level
KFA80C	3.8 psi	2.7 psi
KFA135C	5.5 psi	3.5 psi
KFA220C	8.5 psi	6.5 psi

NOTE : USE ONLY ORIGINAL EQUIPMENT REPLACEMENT PARTS.

Use of alternate or third party components will void any warranty and may cause unsafe operating condition.

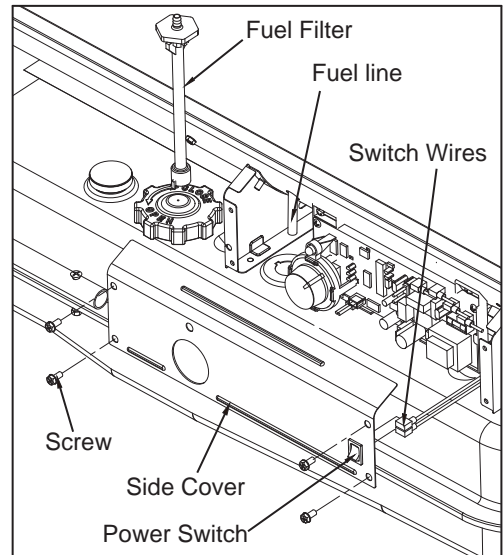

Figure 19. Fuel Filter Replacement

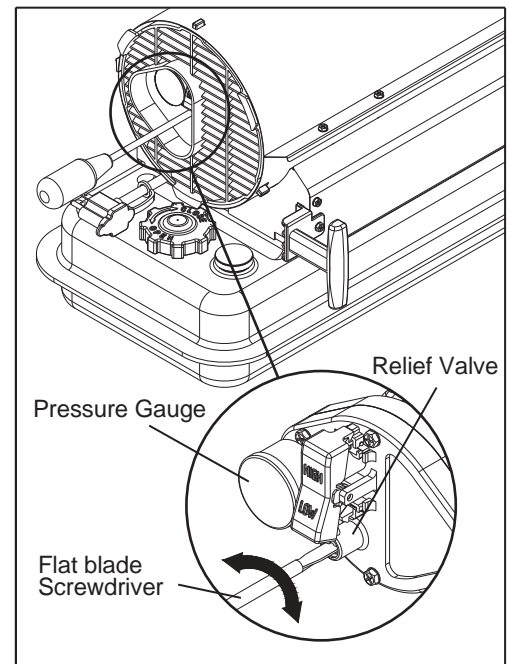

Figure 20. Adjusting Pump Pressure

**NEVER LEAVE THE HEATER
UNATTENDED WHILE BURNING!**

10. REPLACING FUSE

NOTICE : This heater is fuse protected.

If your heater fails to ignite, DO NOT RETURN YOUR HEATER TO THE STORE.

Please follow the simple instruction below to inspect and change the fuse.

PROCEDURE FOR REPLACING FUSE

⚠ WARNING : SHOCK HAZARD

To prevent personal injury, unplug the power cord before replacing fuse.

1. Unplug heater.
2. Remove side cover screws using medium phillips screw driver.
3. Disconnect switch wires from power switch.
4. Remove fuse from fuse holder.(See Figure 21.)
5. Replace fuse.

⚠ WARNING : FIRE HAZARD

To avoid fire, Do not substitute with a higher or lower current rating.

6. Replace switch wires to power switch.
7. Replace side cover.

NOTE : Specified fuse rating : AC 125/8A

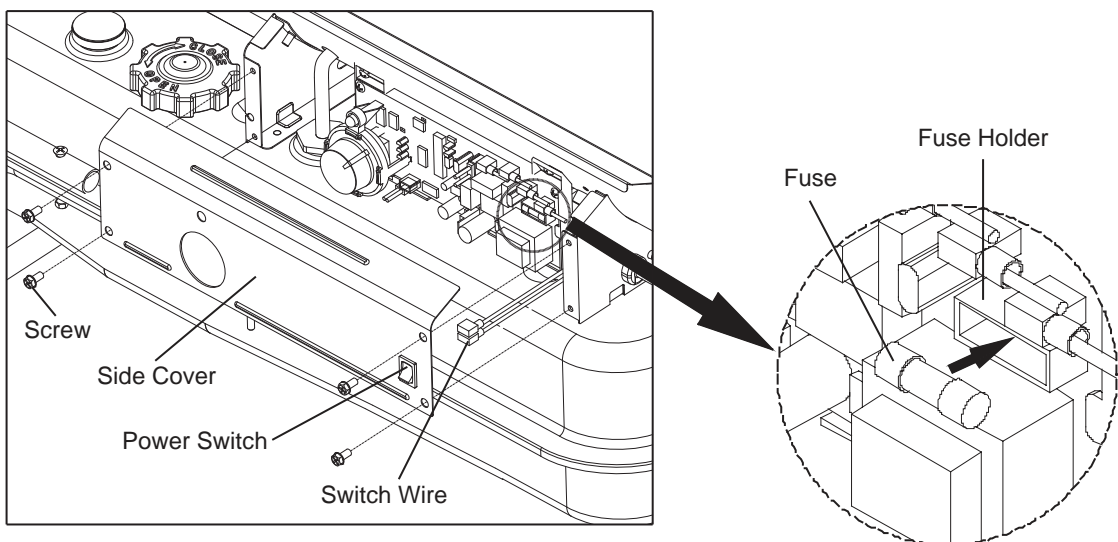

Figure 21. Replacing Fuse

**NEVER LEAVE THE HEATER
UNATTENDED WHILE BURNING!**

11. TROUBLE SHOOTING GUIDE

TROUBLE	POSSIBLE CAUSE	CORRECTIVE ACTION
Heater ignites but MAIN PCB assembly shuts heater off after a short period of time. (Indicator Lamp is flickering and room temp. display indicates " E1 ")	<ol style="list-style-type: none"> 1. Wrong pump pressure 2. Dirty Air Output,Air Intake or Lint Filter. 3. Dirty Fuel Filter. 4. Dirt in Nozzle. 5. Dirty Photocell Lens. 6. Photocell Assembly not Properly installed.(Not seeing the flame) 7. Bad electrical connection between photocell and MAIN PCB assembly. 8. Defective Photocell. 	<ol style="list-style-type: none"> 1. See Pump Pressure Adjustment, Page 13. 2. See Air Output,Air intake and Lint Filters, page 10. 3. See Fuel Filter, Page 13. 4. See Nozzle, Page 11. 5. Clean Photocell Lens, Page 12. 6. Make sure photocell boot is properly seated in bracket, Page 12. 7. Check electrical components See wiring diagram, Page 16. 8. Replace Photocell, Page 12.
Heater will not ignite but motor runs for a short period of time.(Indicator Lamp is flickering and room temp.display indicates " E1 ")	<ol style="list-style-type: none"> 1. No fuel in tank. 2. Wrong pump pressure. 3. Carbon deposits on spark plug and/or improper gap. 4. Dirty fuel filter. 5. Dirt in Nozzle. 6. Water in fuel tank. 7. Bad electrical connection between ignitor and MAIN PCB assembly. 8. Ignitor wire is not attached to spark plug. 	<ol style="list-style-type: none"> 1. Fill tank with kerosene. 2. See Pump Pressure Adjustment, Page 13. 3. See Spark Plug,Page 12. 4. See Fuel Filter,Page 13. 5. See Nozzle,Page 11. 6. Flush fuel tank with clean kerosene, Page 9. 7. Check electrical components See wiring diagram, Page 16. 8. Attach ignitor wire to spark plug. See Spark Plug, Page 12.
Fan does not turn when heater is plugged in and power switch was in the " ON " Position. (Indicator Lamp is on or flickering)	<ol style="list-style-type: none"> 1. Thermostat setting is too low. 2. Bad electrical connection between motor and MAIN PCB assembly. 	<ol style="list-style-type: none"> 1. Turn thermostat control knob to a higher setting. 2. Check electrical connections, See Wiring Diagram, Page 16.
(Indicator Lamp is flickering and room temp. display indicates "E2")	<ol style="list-style-type: none"> 1. Sensor Failure. 	<ol style="list-style-type: none"> 1. Replace sensor. See Wiring diagram, Page 16.
(Indicator Lamp is flickering and room temp. display indicates "E3")	<ol style="list-style-type: none"> 1. Thermostat switch failure. 	<ol style="list-style-type: none"> 1. Replace switch. See Wiring diagram, Page 16.
Heater will not turn-on (Indicator Lamp is off)	<ol style="list-style-type: none"> 1. Temperature limit safety device is overheated. 2. No electrical power 3. Blown fuse. 4. Bad electrical connection between temperature limit safety device and PCB board. 	<ol style="list-style-type: none"> 1. Turn power switch to "OFF" and allow to cool(about 10 min.) 2. Check to insure heater cord and extension cord are plugged in. Check power supply. 3. Replace safety fuse in PCB board. 4. Check electrical connections See Wiring Diagram, Page 16.

NEVER LEAVE THE HEATER UNATTENDED WHILE BURNING!

12. WIRING DIAGRAM

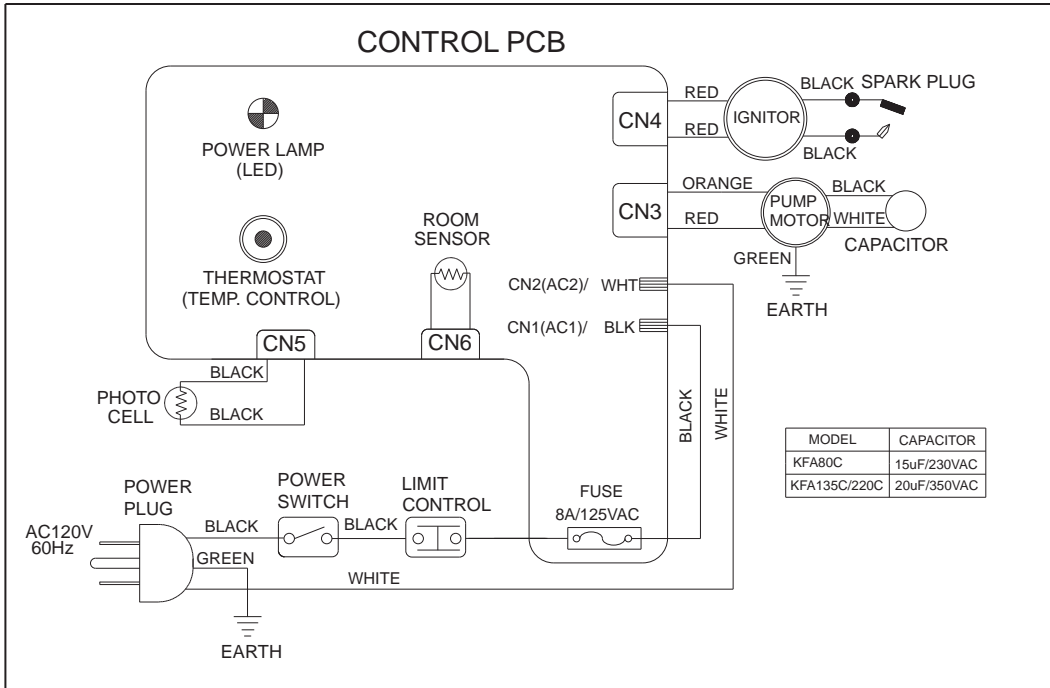

NEVER LEAVE THE HEATER UNATTENDED WHILE BURNING!

13. SPECIFICATIONS

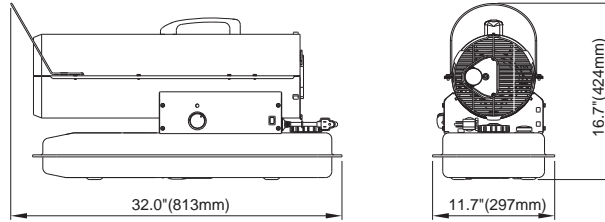

KFA80C Model

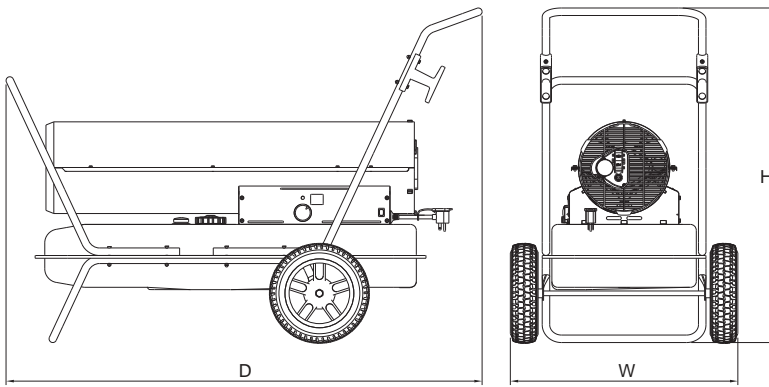

	KFA135C	KFA220C
D	41.9"(1,063 mm)	47.4"(1,205 mm)
W	21.5"(547 mm)	23.1"(587 mm)
H	32.4"(824 mm)	33.5"(850 mm)

KFA135C / KFA220C Models

MODEL		KFA80C	KFA135C	KFA220C
BTU/Hr.	HIGH	80,000	135,000	220,000
	LOW	55,000	95,000	180,000
Fuel Consumption - Gal./Hr(ℓ/Hr)	HIGH	0.60(2.27)	1.02(3.86)	1.66(6.28)
	LOW	0.42(1.59)	0.72(2.73)	1.36(5.15)
Fuel Tank Capacity - Gal.(ℓ/Hr)		5(18.9)	10(37.9)	13(49.2)
Pump Pressure PSI(kgf/cm ²)	HIGH	3.8(0.27)	5.5(0.39)	8.5(0.60)
	LOW	2.7(0.19)	3.5(0.25)	6.5(0.46)
Volt/Hz		120Vac/60Hz	120Vac/60Hz	120Vac/60Hz
Amps.		1.6	2.5	3.7
Phase		1	1	1
Size(D × W × H), Inch(mm)		32.0×11.7×16.7 (813×297×424)	41.9×21.5×32.4 (1,063×547×824)	47.4×23.1×33.5 (1,205×587×850)
Weight Lbs.(kg)		26.9(12.2)	52.2(23.7)	60.2(27.3)

**NEVER LEAVE THE HEATER
UNATTENDED WHILE BURNING!**

14. EXPLODED PARTS DRAWING (KFA80C/135C Models Only)

NOTE : SPECIFY MODEL NUMBER AND PART NUMBER WHEN ORDERING PARTS.

BURNER HEAD ASSEMBLY

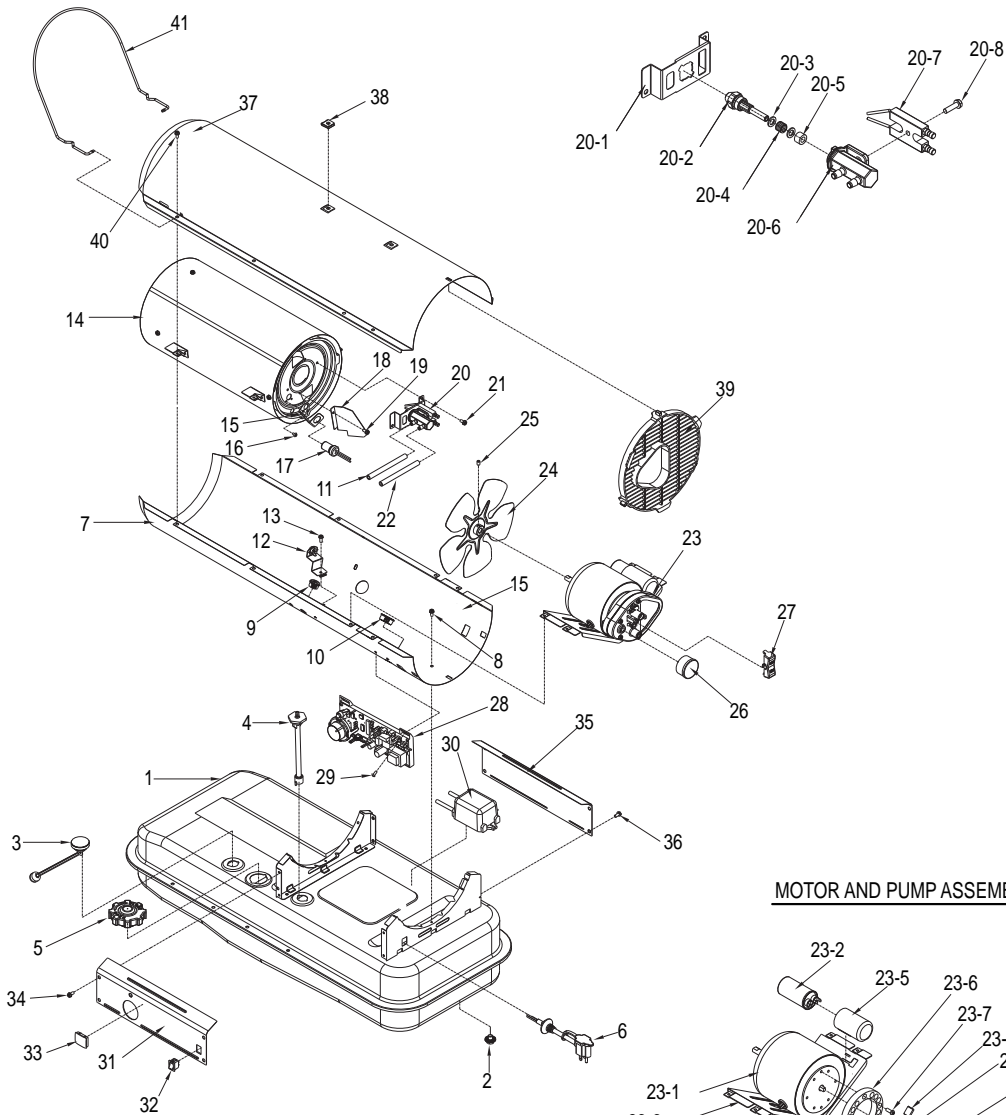

MOTOR AND PUMP ASSEMBLY

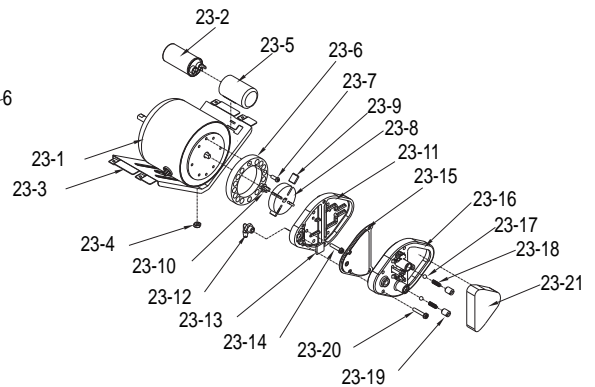

**NEVER LEAVE THE HEATER
UNATTENDED WHILE BURNING!**

15. PARTS LIST (KFA80C/135C Models Only)

KEY NO.	DESCRIPTION	PART NO.		Quantity
		KFA80C	KFA135C	
1	Fuel Tank Assembly	2151-0047-01	2151-0048-01	1
2	Fuel Drain-Bolt	-	4329-0072-00	1
3	Fuel Gauge	2156-0049-00	2156-0051-00	1
4	Fuel Filter Assembly	2155-0005-00	2155-0001-00	1
5	Fuel Cap	2151-0041-00	2151-0041-00	1
6	Power Cord	3980-0275-00	3980-0275-00	1
7	Shell Lower	3111-0501-03	3111-0506-03	1
8	Flange Screw	4319-0015-00	4319-0015-00	4
9	Bushing-Grommet(S)	3231-0120-00	3231-0120-00	1
10	Bushing-Grommet(L)	3231-0121-00	3231-0121-00	2
11	Air-Line	3341-0035-00	3341-0036-00	1
12	Temperature Limit Assembly	2153-0013-00	2153-0013-00	1
13	Flange-Screw	4319-0015-00	4319-0015-00	1
14	Chamber Assembly	2152-0227-00	2152-0230-00	1
15	Bracket Photocell	3131-0159-00	3131-0159-00	1
16	Screw-BH1	4311-0068-00	4311-0068-00	2
17	Photocell Assembly	*SP-KFA1007	*SP-KFA1007	1
18	Air Deflector	3131-0574-00	3131-0575-00	2
19	Flange Screw	4319-0015-00	4319-0015-00	2
20	Bumer Head Assembly	2152-0228-00	2152-0193-00	1
20-1	Bracket Adaptor	3131-0576-00	3131-0576-00	1
20-2	Nozzle	*SP-KFA1027	*SP-KFA1003	1
20-3	Washer-Nozzle Seal	4349-0016-00	4349-0016-00	2
20-4	Spring-Nozzle Seal	3431-0010-00	3431-0010-00	1
20-5	O-Ring	3311-0002-00	3311-0002-00	1
20-6	Nozzle adaptor	3231-0180-00	3231-0180-00	1
20-7	Spark Plug	*SP-KFA1021	*SP-KFA1021	1
20-8	Bolt-Flange	4329-0079-00	4329-0079-00	1
21	Flange Screw	4319-0015-00	4319-0015-00	2
22	Fuel Line	3341-0034-00	3341-0032-00	1
23	Motor and Pump Assembly	2154-0140-00	2154-0141-00	1
23-1	Motor	3970-0210-00	3970-0211-00	1
23-2	Capacitor	3820-0257-00	3820-0258-00	1
23-3	Motor Support	3111-0440-00	3111-0439-00	1
23-4	Nut-Hex	4331-0022-00	4331-0022-00	2
23-5	Capacitor Holder	-	3231-0182-00	1
23-6	Pump Body	3541-0022-00	3541-0022-00	1
23-7	Bolt-BH Special	4321-0198-00	4321-0198-00	2
23-8	Rotor	See SP-KFA1000 ¹	See SP-KFA1000 ¹	1
23-9	Blade	See SP-KFA1000 ¹	See SP-KFA1000 ¹	4

**NEVER LEAVE THE HEATER
UNATTENDED WHILE BURNING!**

15. PARTS LIST (KFA80C/135C Models Only)

KEY NO.	DESCRIPTION	PART NO.		Quantity
		KFA80C	KFA135C	
23-10	Insert	See SP-KFA1000 ¹	See SP-KFA1000 ¹	1
23-11	End Pump Cover	3531-0027-00	3531-0027-00	1
23-12	Elbow	3231-0181-00	3231-0181-00	1
23-13	Lint Filter	See SP-KFA1005 ²	See SP-KFA1005 ²	1
23-14	Bolt Flange	4329-0016-00	4329-0016-00	6
23-15	Output Filter	See SP-KFA1005 ²	See SP-KFA1005 ²	1
23-16	End Filter Cover	3221-0076-00	3221-0076-00	1
23-17	Ball	See SP-KFA1010 ³	See SP-KFA1010 ³	2
23-18	Spring	See SP-KFA1010 ³	See SP-KFA1010 ³	2
23-19	Adjusting Screw	See SP-KFA1010 ³	See SP-KFA1010 ³	2
23-20	Bolt Flange	4329-0016-00	4329-0016-00	4
23-21	Intake Filter	See SP-KFA1005 ²	See SP-KFA1005 ²	1
24	Fan Assembly	2154-0009-00	2154-0004-00	1
25	Bolt Headless Hex Socket	4323-0004-00	4323-0004-00	1
26	Pressure Gauge	3740-0049-00	3740-0049-00	1
27	BTU Control Switch	2154-0070-00	2154-0070-00	1
28	Main P.C.B Assembly	215A-0073-00	215A-0074-00	1
29	Screw-TH2S	4312-0046-00	4312-0046-00	2
30	Ignitor	39E0-0071-00	39E0-0071-00	1
31	Side Cover-Right	3121-0497-27	3121-0498-19	1
32	Power Switch	39A0-0191-00	39A0-0191-00	1
33	Window Display	-	3231-0113-00	1
34	Flange Screw	4319-0015-00	4319-0015-00	4
35	Side Cover-Left	3121-0350-00	3121-0352-00	1
36	Flange Screw	4319-0015-00	4319-0015-00	4
37	Shell Upper	3111-0502-03	3111-0507-03	1
38	Clip Nut	3131-0182-00	-	2
39	Fan Guard	3221-0074-00	3221-0075-00	1
40	Flange Screw	4319-0015-00	4319-0015-00	8
41	Front Guard	3561-0066-00	-	1

KEY NO.	DESCRIPTION	KFA80C	KFA135C	Quantity
1	Rotor kit	SP-KFA1000	SP-KFA1000	1
2	Filter kit	SP-KFA1005	SP-KFA1005	1
3	Plug/Pump adjuster kit	SP-KFA1010	SP-KFA1010	2

**FOR TECHNICAL ASSISTANCE SEE YOUR LOCAL RETAILER OR
CONTACT US AT:**

Phone : 1-877-447-4768

NEVER LEAVE THE HEATER UNATTENDED WHILE BURNING!

14. EXPLODED PARTS DRAWING (KFA220C Model Only)

NOTE : SPECIFY MODEL NUMBER AND PART NUMBER WHEN ORDERING PARTS.

BURNER HEAD ASSEMBLY

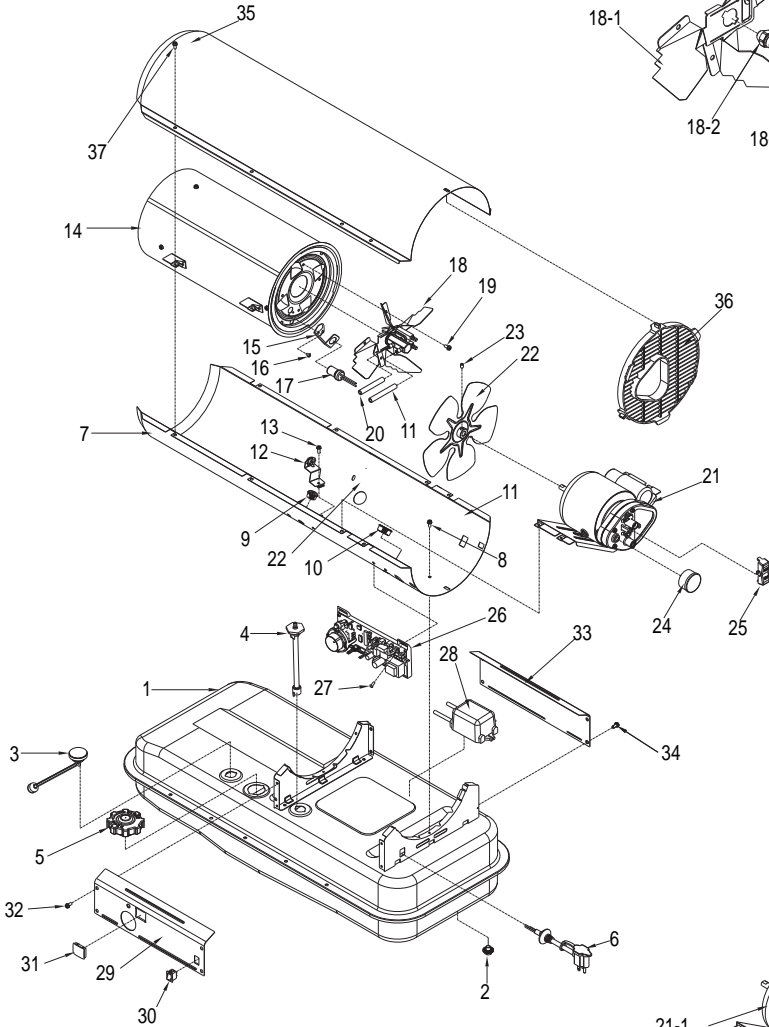
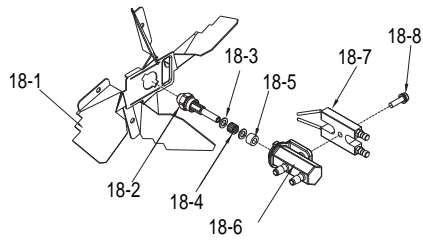

MOTOR AND PUMP ASSEMBLY

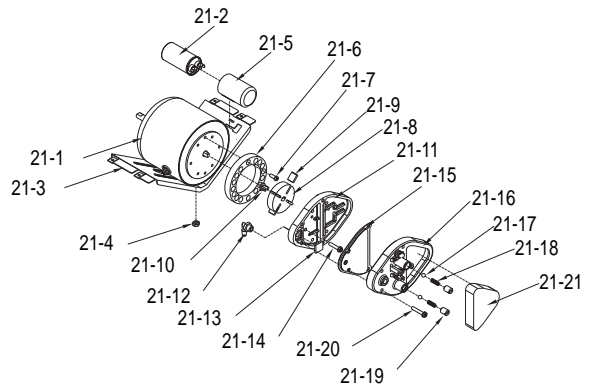

**NEVER LEAVE THE HEATER
UNATTENDED WHILE BURNING!**

15. PARTS LIST (KFA220C Model Only)

KEY NO.	DESCRIPTION	PART NO.	Quantity
		KFA220C	
1	Fuel Tank Assmebly	2151-0049-01	1
2	Fuel Drain-Bolt	4329-0072-00	1
3	Fuel Gauge	2156-0052-00	1
4	Fuel Filter Assmby	2155-0001-00	1
5	Fuel Cap	2151-0041-00	1
6	Power Cord	3980-0275-00	1
7	Shell Lower	3111-0504-03	1
8	Flange Screw	4319-0015-00	4
9	Bushing-Grommet(S)	3231-0120-00	1
10	Bushing-Grommet(L)	3231-0121-00	2
11	Air-Line	3341-0036-00	1
12	Temperature Limit Assembly	2153-0005-00	1
13	Flange-Screw	4319-0015-00	1
14	Chamber Assembly	2152-0050-00	1
15	Bracket Photocell	3131-0159-00	1
16	Screw-BH1	4311-0068-00	2
17	Photocell Assembly	*SP-KFA1007	1
18	Burner Head Assembly	2152-0124-00	1
18-1	Bracket Burner	3121-0477-00	1
18-2	Nozzle	*SP-KFA1011	1
18-3	Washer-Nozzle Seal	4349-0016-00	1
18-4	Spring-Nozzle Seal	3431-0010-00	1
18-5	O-Ring	3311-0002-00	1
18-6	Nozzle Adaptor	3231-0180-00	1
18-7	Spark Plug	*SP-KFA1021	1
18-8	Bolt-Flange	4329-0079-00	1
19	Flange Screw	4319-0015-00	4
20	Fuel Line	3341-0039-00	1
21	Motor and Pump Assembly	2154-0137-00	1
21-1	Motor	3970-0213-00	1
21-2	Capacitor	3820-0258-00	1
21-3	Supportor Motor	3111-0439-00	1
21-4	Nut-Hex	4331-0022-00	2
21-5	Holder Capacitor	3231-0182-00	1
21-6	Pump Body	3541-0050-00	1
21-7	Bolt-BH Special	4321-0198-00	2
21-8	Rotor	See SP-KFA1022 ¹	1
21-9	Blade	See SP-KFA1022 ¹	4
21-10	Insert	See SP-KFA1022 ¹	1
21-11	End Pump Cover	3531-0027-00	1

**NEVER LEAVE THE HEATER
UNATTENDED WHILE BURNING!**

15. PARTS LIST (KFA220C Model Only)

KEY NO.	DESCRIPTION	PART NO.	Quantity
		KFA220C	
21-12	Elbow	3231-0181-00	1
21-13	Lint Filter	See SP-KFA1005 ²	1
21-14	Bolt Flange	4329-0016-00	6
21-15	Output Filter	See SP-KFA1005 ²	1
21-16	End Filter Cover	3221-0076-00	1
21-17	Ball	See SP-KFA1010 ³	2
21-18	Spring	See SP-KFA1010 ³	2
21-19	Adjusting Screw	See SP-KFA1010 ³	2
21-20	Bolt Flange	4329-0016-00	4
21-21	Intake Filter	See SP-KFA1005 ²	1
22	Fan Assembly	2154-0007-00	1
23	Bolt Headless Hex Socket	4323-0004-00	1
24	Pressure Gauge	3740-0049-00	1
25	BTU Control Switch	2154-0070-00	1
26	Main P.C.B Assembly	215A-0074-00	1
27	Screw-TH2S	4312-0046-00	2
28	Ignitor	39E0-0071-00	1
29	Side Cover-Right	3121-0499-44	1
30	Power Switch	39A0-0191-00	1
31	Window Display	3231-0113-00	1
32	Flange Screw	4319-0015-00	4
33	Side Cover-Left	3121-0354-00	1
34	Flange Screw	4319-0015-00	4
35	Shell Upper	3111-0505-03	1
36	Fan Guard	3221-0075-00	1
37	Flange Screw	4319-0015-00	8

KEY NO.	DESCRIPTION	KFA220C	Quantity
1	Rotor kit	SP-KFA1022	1
2	Filter kit	SP-KFA1005	1
3	Plug/Pump adjuster kit	SP-KFA1010	2

**FOR TECHNICAL ASSISTANCE SEE YOUR LOCAL RETAILER OR
CONTACT US AT:**

Phone : 1-877-447-4768

**NEVER LEAVE THE HEATER
UNATTENDED WHILE BURNING!**

15. PARTS LIST (WHEELS AND HANDLE)

1) KFA80C MODEL

KEY NO.	DESCRIPTION	PART NO.	Quantity
		KFA80C	
1	Handle	3231-0073-00	1
2	Cord Wrap	3221-0041-00	2

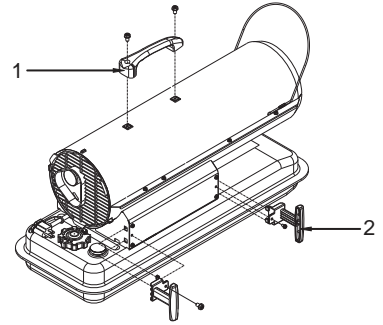

2) KFA135C/220C MODELS

KEY NO.	DESCRIPTION	PART NO.		Quantity
		KFA135C	KFA220C	
1	Front Handle	3551-0023-00	3551-0022-00	1
2	Rear Handle	3551-0096-00	3551-0097-00	1
3	Wheel Support Frame	3551-0082-00	3551-0084-00	1
4	Wheel	3720-0017-00	3720-0017-00	2
5	Threaded Axle	3551-0088-00	3551-0089-00	1
6	Cord Wrap	3221-0042-00	3221-0042-00	2
7	Hardware Kit	HW-KFA1016	HW-KFA1016	1
7-1	Screw	INCLUDED IN HARDWARE KIT	INCLUDED IN HARDWARE KIT	8
7-2	Flange Screw	INCLUDED IN HARDWARE KIT	INCLUDED IN HARDWARE KIT	4
7-3	Cap Nut S	INCLUDED IN HARDWARE KIT	INCLUDED IN HARDWARE KIT	4
7-4	Nut	INCLUDED IN HARDWARE KIT	INCLUDED IN HARDWARE KIT	8
7-5	Bushing	INCLUDED IN HARDWARE KIT	INCLUDED IN HARDWARE KIT	2
7-6	Cap Nut L	INCLUDED IN HARDWARE KIT	INCLUDED IN HARDWARE KIT	2

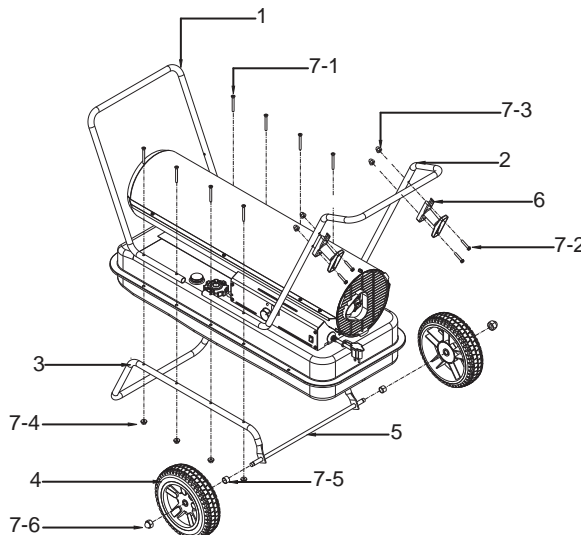

Warranty

LIMITED WARRANTY:

This limited warranty is extended to the original retail purchaser of this Forced Air/Convection/Radiant Heater and warrants against any defect in materials and workmanship for a period of one (1) year from the date of retail sale. GHP Group, Inc., at its option, will either provide replacement parts or replace or repair the unit, when properly returned to the retailer where purchased or one of our service centers as directed by GHP Group, Inc., within one (1) year of retail purchase. (Shipping costs, labour costs, etc. are the responsibility of the purchaser.)

DUTIES OF THE OWNER:

This heating appliance must be operated in accordance with the written instructions furnished with this heater. This warranty shall not excuse the owner from properly maintaining this heater in accordance with the written instructions furnished with this heater. A bill of sale, canceled check or payment record must be kept to verify purchase data and establish warranty period. Original carton should be kept in case of warranty return of unit.

WHAT IS NOT COVERED:

1. Damage resulting from use of improper fuel.
2. Damage caused by misuse or use contrary to the owners manual and safety guidelines.
3. Damage caused by a lack of normal maintenance.
4. Fuses
5. Use of non-standard parts or accessories.
6. Damage caused in transit. Freight charges on warranty parts or heaters to and from the factory shall be the responsibility of the owner.

This warranty does not imply or assume any responsibility for consequential damages that may result from the use, misuse, or the lack of routine maintenance of this heating appliance. A cleaning fee and the cost of parts may be charged for appliance failures resulting from lack of maintenance. This warranty does not cover claims which do not involve defective workmanship or materials. **FAILURE TO PERFORM GENERAL MAINTENANCE (INCLUDING CLEANING) WILL VOID THIS WARRANTY.**

THIS LIMITED WARRANTY IS GIVEN TO THE PURCHASER IN LIEU OF ALL OTHER WARRANTIES, EXPRESSED OR IMPLIED, INCLUDING BUT NOT LIMITED TO THE WARRANTIES OF MERCHANTABILITY OF FITNESS FOR A PARTICULAR PURPOSE. THE REMEDY PROVIDED IN THIS WARRANTY IS EXCLUSIVE AND IS GRANTED IN LIEU OF ALL OTHER REMEDIES. IN NO EVENT WILL GHP GROUP, INC. BE LIABLE FOR INCIDENTAL OR CONSEQUENTIAL DAMAGES.

Some states do not allow limitations on how long an implied warranty lasts, so the above limitation may not apply to you. Some states do not allow the exclusion or limitation of incidental or consequential damages so the above limitation or exclusion may not apply to you.

CLAIMS HANDLED AS FOLLOWS:

1. Contact your retailer and explain the problem.
2. If the retailer is unable to resolve the problem, contact our Customer Service Dept. detailing the heater model, the problem, and proof of date of purchase.
3. A representative will contact you. **DO NOT RETURN THE HEATER TO GHP GROUP, INC.** unless instructed by our Representative. This warranty gives you specific legal rights and you may also have other rights which vary from state to state.

TO REGISTER THE WARRANTY ON YOUR HEATER, PLEASE FILL OUT THIS CARD COMPLETELY
AND MAIL WITHIN 14 DAYS FROM DATE OF PURCHASE OR REGISTER ON-LINE AT www.ghpgroupinc.com

NAME: _____ PHONE: () _____ EMAIL: _____
ADDRESS: _____ CITY: _____ STATE: _____ ZIP: _____
MODEL: _____ SERIAL#: _____ DATE PURCHASED: _____
DEALER PURCHASED FROM: _____ TYPE OF STORE: _____
CITY & STATE WHERE PURCHASED: _____ PRICE PAID: _____

**Please Take 1 Minute To Give Us Your Answers To The Following Questions.
All Responses Used Solely For Market Research And Are Held In Strict Confidence.**

Who primarily decided this purchase? Male Female 18-24 25-39 40-59 60 and over of age?
Do you own any other portable heaters? Yes No If yes, type _____ brand _____
How do you intend to use your new heater? Construction Site Farm Warehouse/Commercial Garage/Outbuilding Other
How did you become aware of this heater? In-Store Display Newspaper Ad Magazine Ad Friend/Relative
 TV Commercial Store Salesperson Other _____
What made you select this heater? Style Size/Portability Price Package Brand Other _____
Do you: Own Rent Would you recommend this heater to a friend? Yes No
Please give us your comments _____

THANK YOU FOR COMPLETING THIS FORM!
Information will be held confidential.

WARRANTY REGISTRATION

IMPORTANT: We urge you to fill out your warranty registration card within fourteen (14) days of date of purchase. You can also register your warranty on the internet at www.ghpgroupinc.com. Complete the entire serial number. Retain this portion of the card for your records.



GHP Group, Inc.
6440 W Howard St
Niles, IL 60714-3302

Tel: (877) 447-4768
www.ghpgroupinc.com

SAVE THIS CARD!

Place
Postage
Stamp
Here

GHP Group, Inc.
6440 W Howard St
Niles, IL 60714-3302