

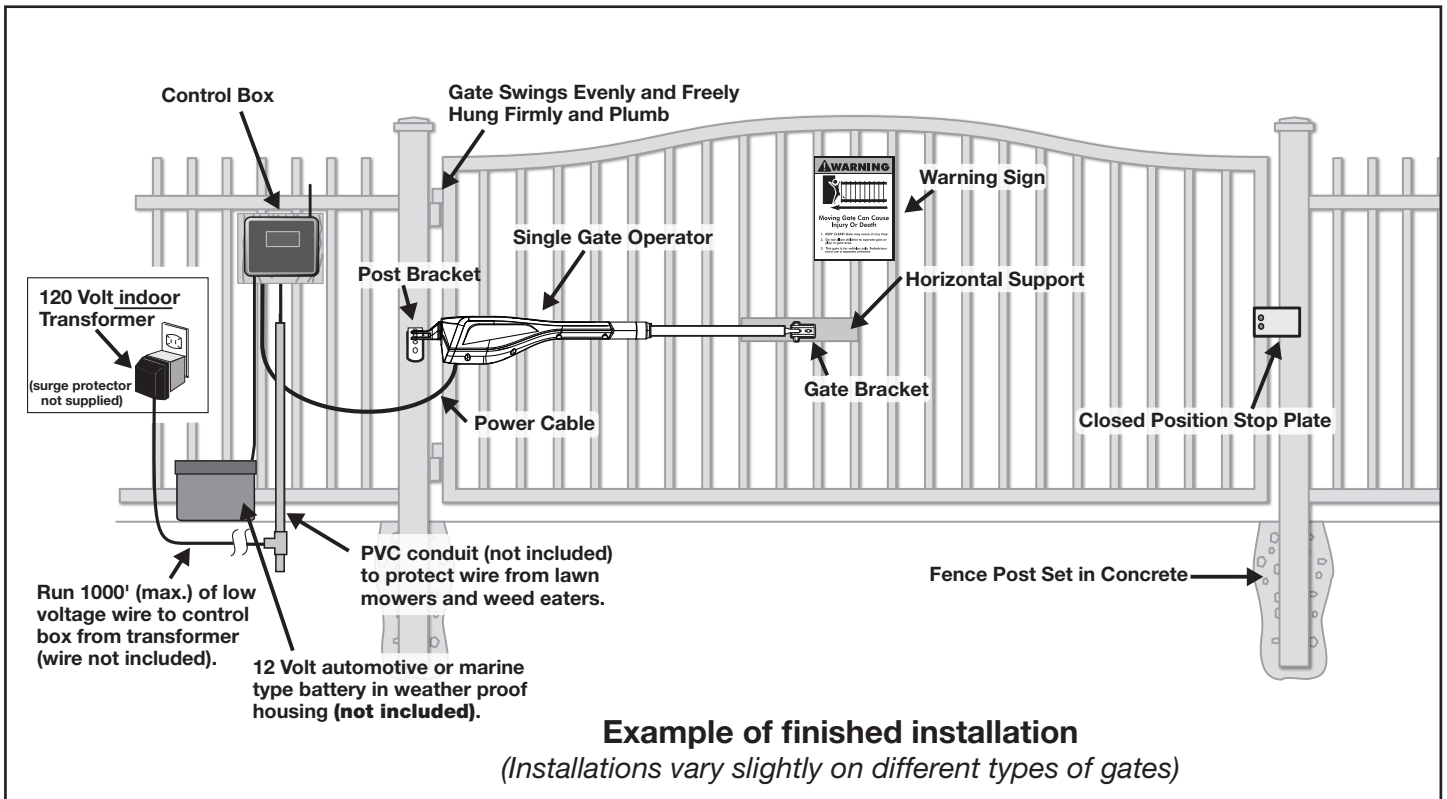

# MM271

## Installation Manual



This product meets the requirements of UL325, the standard for gate operator safety.

# **WARNING**

**DO NOT SPLICE ANY  
POWER WIRES!**

**DO NOT MODIFY THE  
BATTERY HARNESS!**

**THIS WILL VOID YOUR  
MANUFACTURER'S  
WARRANTY.**

Low voltage wire for transformer not included.



# WARNING

This equipment meets Underwriters Laboratory Standard 325 (UL 325). However, gate equipment has hazards associated with its use and therefore by installing this product the installer and user accept full responsibility for following and noting the installation and safety instructions. Failure to follow installation and safety instructions can result in hazards developing due to improper assembly. You agree to properly install this product and that if you fail to do so Nortek Security & Control, LLC, shall in no event be liable for direct, indirect, incidental, special or consequential damages or loss of profits whether based in contract tort or any other legal theory during the course of the warranty or at any time thereafter. The installer and/or user agree to assume responsibility for all liability and use of this product releasing Nortek Security & Control, LLC, from any and all liability. If you are not in agreement with this disclaimer or do not feel capable of properly following all installation and safety instructions you may return this product for full replacement value.

**READ ALL INSTRUCTIONS CAREFULLY AND COMPLETELY** before attempting to install and use this automatic gate operator. This gate operator produces a high level of force. Stay clear of the unit while it is operating and exercise caution at all times.

**ALL AUTOMATIC GATE OPERATORS ARE INTENDED FOR USE ON VEHICULAR GATES ONLY.**

## Product Usage

The Mighty Mule Gate Operator meets all of the safety requirements of a **Class I** Residential Vehicular Gate Operator and is intended for use solely with vehicular swing gates in single-family residential applications that meet the Class I category listed in the table below.

## **Vehicular Gate Operator Class Categories**

### **Residential Vehicular Gate Operator-Class I:**

A vehicular gate operator (or system) intended for use in garages or parking areas associated with a residence of one-to-four single families.

### **Commercial/General Access Vehicular Gate Operator-Class II:**

A vehicular gate operator (or system) intended for use in a commercial location or building such as a multi-family housing unit (five or more single family units), hotel, garages, retail store, or other buildings accessible by or servicing the general public.

### **Industrial/Limited Access Vehicular Gate Operator–Class III:**

A vehicular gate operator (or system) intended for use in an industrial location or building such as a factory or loading dock area or other locations not accessible by or intended to service the general public.

### **Restricted Access Vehicular Gate Operator – Class IV:**

A vehicular gate operator (or system) intended for use in an industrial location or building such as a factory or loading dock area or other locations not accessible by or intended to service the general public.

# Table of Contents

<b>Please Read This First!</b> .....	<b>2</b>
<b>Important Safety Information</b> .....	<b>3</b>
Manually Opening and Closing Gate .....	3
For the Installer and End User.....	4
Installing Warning Signs and Pedestrian Gates .....	8
Required Safety Precautions for Gates.....	9
<b>Technical Specifications</b> .....	<b>10</b>
Mighty Mule 271 Gate Opener.....	10
<b>Before You Begin</b> .....	<b>11</b>
Powering Options .....	11
Solar Panel and Gate Activity Chart.....	11
Check Existing Gate Size and Material.....	12
IMPORTANT: Check for Proper Gate Installation .....	12
Items Included .....	13
Tools Needed .....	14
Items Not Included .....	14
<b>Installation</b> .....	<b>15</b>
Closed Position Stop Plate Installation .....	17
Control Box & Battery Installation .....	18
Transformer Wiring Installation .....	19
Solar Panel Installation.....	20
Transmitter Programming.....	21
Setting Closed Limit Position .....	23
Setting Dual Sense Detection & Auto Close Timer .....	24
Connecting Additional Devices .....	25
Control Board Connections.....	26
Connecting Accessories .....	27
<b>Maintenance</b> .....	<b>28</b>
<b>Troubleshooting Guide</b> .....	<b>29</b>
Audible Feedback.....	29
Visual Feedback.....	30
<b>Accessories</b> .....	<b>32</b>
<b>Gate Operator Installation Checklist</b> .....	<b>34</b>

# Please Read This First!

Thank you for purchasing a Mighty Mule Gate Operator—Nortek Security & Control's "do-it-yourself" automatic gate operator! When correctly installed and properly used, your Mighty Mule Gate Operator will give you many years of reliable service. Please read the following information to ensure you have the correct system for your particular needs. If so, this manual will enable you to properly install your Mighty Mule Gate Operator.

The Mighty Mule Gate Operator is designed for installation on a pull-to-open single leaf gate (gates that open into the property). The gate must not exceed 12 feet in length or weigh more than 300 pounds (please see **Technical Specifications** on [page 10](#)). The Mighty Mule Gate Operator can be used on vinyl, aluminum, chain link, farm tube, and wrought iron gates.

 Not rated for use on solid surface gates due to the potential to damage the operator and/or injure someone.

The Mighty Mule Gate Operator accommodates extra transmitters, digital keypads, solar panels, push buttons, automatic gate locks, and other access control products. These optional accessories (see the Mighty Mule Accessory Catalog) are available at most stores. Your store should be able to special order any accessory not in stock. If your store cannot special order accessories, please call the Mighty Mule Sales Department (800-543-4283).

The Mighty Mule Gate Operator features Dual Sense Technology™. This feature makes the gate stop and reverse direction when it comes in contact with an obstruction. This is factory set to the most sensitive setting and must be adjusted during installation.

The Mighty Mule Gate Operator also has an adjustable auto-close feature. After the gate reaches the fully open position, it can be set to remain open up to 120 seconds before automatically closing. Pressing the transmitter button at any time after the gate opens fully will cause it to close immediately. OFF is the factory setting; meaning the gate will stay open until you press the transmitter (or keypad, etc.) again.

Go to [www.mightymule.com](http://www.mightymule.com) for a dealer or retailer near you or call (800) 543-4283 for information about our Linear professional line of gate operators and accessories. Our Sales Department will be glad to give you the name and phone number of a Linear dealer near you.

## **BEFORE YOU BEGIN TO INSTALL YOUR AUTOMATIC GATE OPERATOR:**

**Read these instructions carefully to become familiar with all parts and installation steps.**

**The video is only designed as an overview of the installation procedure.**

**You must read the installation manual for detailed instructions on gate operator safety and proper use of the gate operator.**



NOT FOR THE CONTAINMENT OF ANIMALS.

# Important Safety Information

Because automatic gate operators produce high levels of force, consumers need to know the potential hazards associated with improperly designed, installed, and maintained automated gate operator systems. **Keep in mind that the gate operator is just one component of the total gate operating system.** Each component must work in unison to provide the end user with convenience, security, and safety.

This manual contains various safety precautions and warnings for the installer and end user. Because there are many possible applications of the gate operator, the safety precautions and warnings contained in

this manual cannot be completely exhaustive in nature. It does, however, provide an overview of the safe design, installation, and use of this product. **CAREFULLY READ AND FOLLOW ALL SAFETY PRECAUTIONS, WARNINGS, AND INSTALLATION INSTRUCTIONS TO ENSURE THE SAFE SYSTEM DESIGN, INSTALLATION, AND USE OF THIS PRODUCT.**

 Warnings in this manual are identified with this warning symbol. The symbol identifies conditions that can result in damage to the operator or its components, serious injury, or death.

**Because Mighty Mule automatic gate operators are only part of the total gate operating system, it is the responsibility of the installer and end user to ensure that the total system is safe for its intended use.**

## MANUALLY OPENING AND CLOSING GATE

### CAUTION

The gate will move freely and uncontrolled when the gate operator is removed from the gate. **ONLY disconnect the operator when the control box power switch is OFF and the gate is NOT moving.**

#### Disconnecting the Operator

1. Turn control box power switch OFF.
2. Remove the hairpin clip and clevis pin.
3. Remove the operator's front mount from the gate bracket.

The gate can be opened and closed manually when the operator is disconnected.

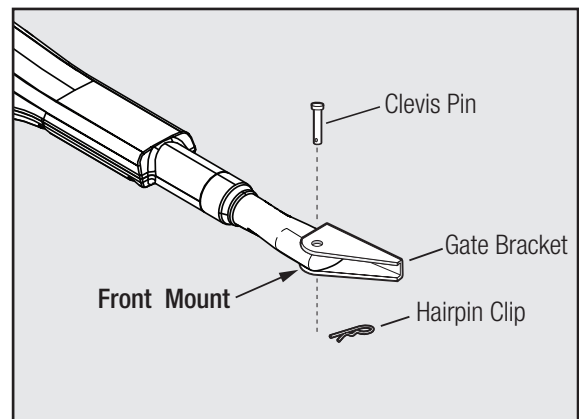

**NOTE:** Substitute a **Pin Lock** for the clevis pin on the front mount of the gate operator to prevent theft of the operator from the gate (see accessory pages in back of this book).

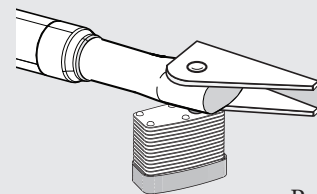

Part #: FM133

# Important Safety Information

## FOR THE INSTALLER AND END USER

### **⚠ WARNING**

#### **To reduce the risk of injury or death:**

- 1. READ AND FOLLOW ALL INSTRUCTIONS.**
- Never let children operate or play with gate controls. Keep the remote control away from children.
- Always keep people and objects away from the gate. **NO ONE SHOULD CROSS THE PATH OF THE MOVING GATE.**
- Test the gate operator monthly. The gate **MUST** reverse on contact with a rigid object or stop when an object activates the non-contact sensors. After adjusting the force or the limit of travel, retest the gate operator. Failure to adjust and retest the gate operator properly can increase the risk of injury or death.
- Use the manual/emergency release only when the gate is not moving.
- 6. KEEP GATES PROPERLY MAINTAINED.** Read the user's manual. Have a qualified service person make repairs to gate hardware.
- The entrance is for vehicles only. Pedestrians must use separate entrance.
- The gate must be installed in a location that provides adequate clearance between it and adjacent structures when opening and closing to reduce the risk of entrapment. Swinging gates must not open into public access areas.
- 9. SAVE THESE INSTRUCTIONS.**

#### **I. Before Installation**

- Verify this operator is proper for the type and size of gate, frequency of use and class of the gate system.
- Make sure the gate has been properly installed and swings freely in both directions. Repair or replace all worn or damaged gate hardware prior to installation. A freely moving gate will require less force to operate and will enhance the performance of the entrapment protection devices used with the system (see [page 12](#)).
- Review the operation of the system to become familiar with its safety features. Understand how to disconnect the operator for manual gate operation (see [page 3](#)).
- The gate and operator installation must comply with any applicable local codes.
- This gate operator is intended for vehicular gates only. A separate entrance or gate must be installed for pedestrian use (see [page 8](#)).
- Always keep people and objects away from the gate and its area of travel. No one should cross the path of a moving gate.
- Identify all of the entrapment zones for the type of installation. An entrapment zone is an area around the automatic gate system where a person or object could be caught that increase the risk of injury. Entrapment zones must be eliminated, guarded or protected.
- When designing a system that will be entered from a highway or main thoroughfare, make sure the gate system is placed far enough from the road to prevent traffic congestion.

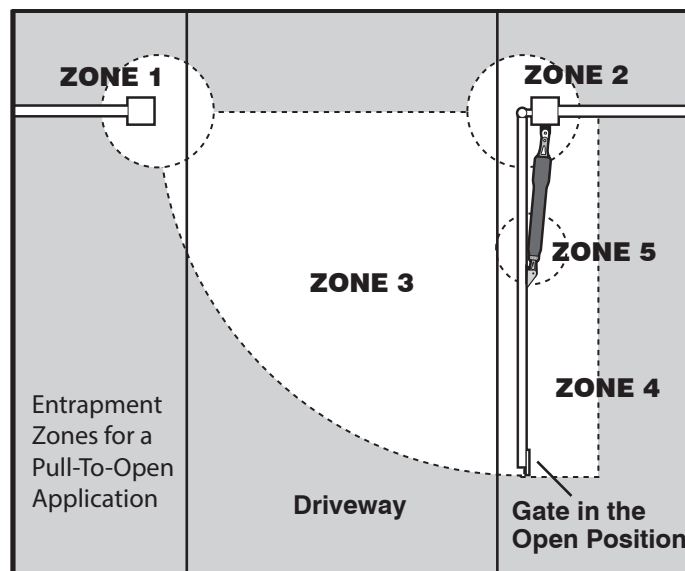



# Important Safety Information

## FOR THE INSTALLER AND END USER

Typical Entrapment Zones are shown in the diagrams on [page 4](#):

**Zone 1** – leading edge of the gate and the fence post.

**Zone 2** – between the gate and the gate post.

**Zone 3** – the path of the gate.

**Zone 4** – the space between the gate in the open position and any object such as a wall, fence, tree, etc.

**Zone 5** – pinch points between the operator and gate.

## II. During Installation

1. Install the gate operator on the inside of the property and fence line. **DO NOT** install an operator on the outside of the gate where the public has access to it.
2. Be careful with moving parts and avoid close proximity to areas where fingers or hands could be pinched.
3. Devices such as contact sensors (sensing edges) and non contact sensors (photo beams) provide additional protection against vehicular damage.
4. If push buttons or key switches are installed, they should be within sight of the gate, located at least 10 feet from any moving part of the gate (see diagram below). **Never install any control device where a user will be tempted to reach through the gate to activate the gate operator.**
5. Do not activate your gate operator unless you can see it and can determine that its area of travel is clear of people, pets, or other obstructions. Watch the gate through its entire movement.
6. Secure outdoor or easily accessed gate operator controls in order to prohibit unauthorized use of the gate.

**NEVER install any control device within gray area**

### Pull-To-Open Application

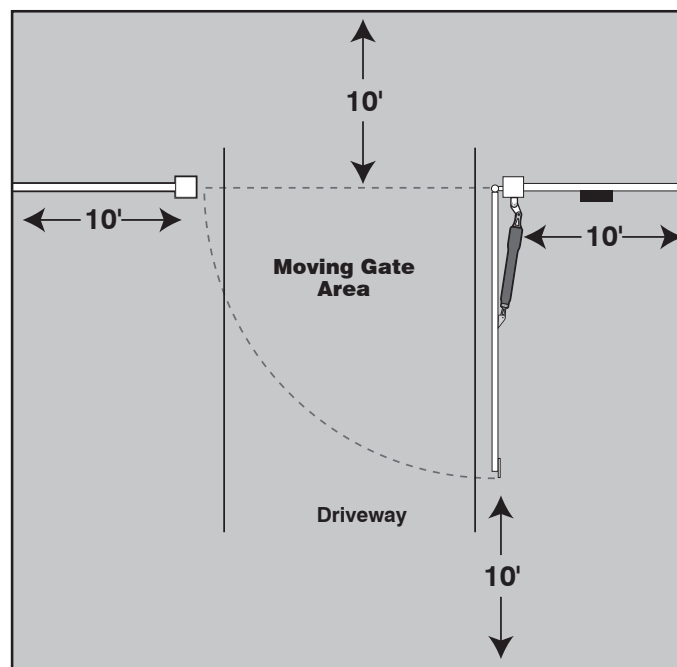

# Important Safety Information

## FOR THE INSTALLER AND END USER

### III. After Installation

1. Attach the **warning signs** (included) to each side of the gate to alert the public of automatic gate operation. It is your responsibility to post warning signs on both sides of your gate. If any of these signs or warning decals becomes damaged, illegible, or missing, replace them immediately. Contact Nortek Security & Control for free replacements.
  2. The gate is automatic and could move at any time, posing serious risk of entrapment. No one should be in contact with the gate when it is moving or stationary.
  3. Do not attempt to drive into the gate area while the gate is moving; wait until the gate comes to a complete stop.
  4. Do not attempt to “beat the gate” while the gate is closing. This is extremely dangerous.
  5. Do not allow children or pets near your gate. **Never let children operate or play with gate controls.** Keep the remote control away from children and unauthorized users; store controls where children and unauthorized users do not have access to them.
  6. **KEEP GATE SYSTEMS MAINTAINED.** Always turn power to operator OFF before performing any maintenance. See [page 28](#) for maintenance procedures.
  7. To operate this equipment safely, YOU must know how to disconnect the operator for manual gate operation (see [page 3](#)). If you have read the instructions and still do not understand how to disconnect the operator, contact the Mighty Mule Service Department.
  8. Disconnect the operator **ONLY** when the power is **TURNED OFF** and the gate is **NOT** moving.
  9. Make arrangements with local fire and law enforcement for emergency access.
  10. Distribute and discuss copies of the **IMPORTANT SAFETY INFORMATION** section of this manual with all persons authorized to use your gate.
  11. **IMPORTANT: Save these safety instructions. Make sure everyone who is using or will be around the gate and gate operator are aware of the dangers associated with automated gate systems. In the event you sell the property with the gate operator or sell the gate operator, provide a copy of these safety instructions to the new owner.**
- Should you need a replacement manual, a copy can be obtained by downloading one from the **Mighty Mule** web site ([www.mightymule.com](http://www.mightymule.com)), by contacting Nortek Security & Control, at 5919 Sea Otter Place, Carlsbad, CA 92010 or by calling 1-800-543-1236 and requesting a duplicate copy.

# Important Safety Information

## FOR THE INSTALLER AND END USER

Mighty Mule gate operators utilize Dual Sense Technology™ entrapment protection. Dual Sense Technology™ is built into every Mighty Mule and provides redundant methods of entrapment protection for open and close gate directions.

In addition to Dual Sense Technology, every Mighty Mule gate controller has provisions for the connection of additional obstruction detection devices such as sensing edges and photo beams.

These devices may be located where there is an increased risk of obstruction. Refer to the diagram below.

One or more edge sensors may be located at the leading edge, bottom edge, and post edge, both inside and outside of a vehicular swing gate system.

Wiring to sensors must be located and arranged so the wiring between the sensor and the gate operator is not subjected to mechanical damage.

A wireless sensor such as one that transmits radio frequency (RF) signals that promote safety shall be located where the transmission of the signals is not obstructed or impeded by building structures, natural landscaping or similar objects.

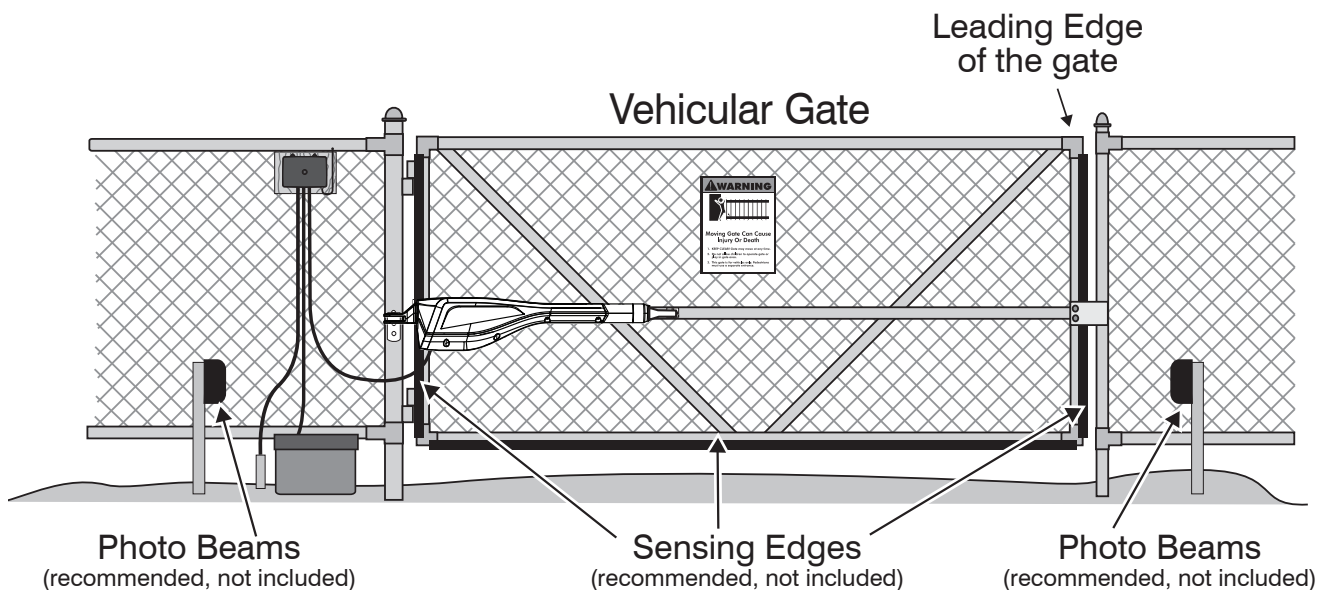

**NOTE:** Photo beams should always be located on the non-travel side of the gate.

## Entrapment and Obstruction Protection

Mighty Mules's Dual Sense Technology™ provides entrapment protection, when properly adjusted. Since all installations are different, you may need to add photo beams or sensing edges to help prevent damage to vehicle or other items that could be hit by a moving gate.

## Entrapment Alarm

The Mighty Mule Automatic Gate Operator is designed to stop and reverse the gate when the gate comes in contact with an obstruction. Additionally, these operators are equipped with an audio entrapment alarm which will activate if the unit obstructs twice while opening or closing. This alarm will sound for a period of 5 minutes, or until the operator receives an intended signal from a hard wired entry/exit source (e.g. push button control or keypad). Turning the power switch on the control box OFF and back ON will also deactivate the alarm. Wireless controls such as transmitters and wireless keypads will not deactivate the alarm.

# Important Safety Information

## INSTALLING WARNING SIGNS AND PEDESTRIAN GATES

Warning signs alert people of automatic gate operation and are required when installing Mighty Mule Automatic Gate Operators. A minimum of two WARNING SIGNS must be installed in the area of the gate. Each sign is to be visible by persons located on the side of the gate on which the placard is installed.

The operator is intended for installation only on gates used for vehicles. Pedestrians must be supplied with a separate access opening. The pedestrian access opening shall be designed to promote pedestrian usage. Locate the gate such that persons will not come in contact with the vehicular gate during the entire path of travel of the vehicular gate.

We recommend using the Bulldog Pedestrian Gate Lock (Call the Nortek Security & Control Sales Department at 800-543-4283) for controlled access.

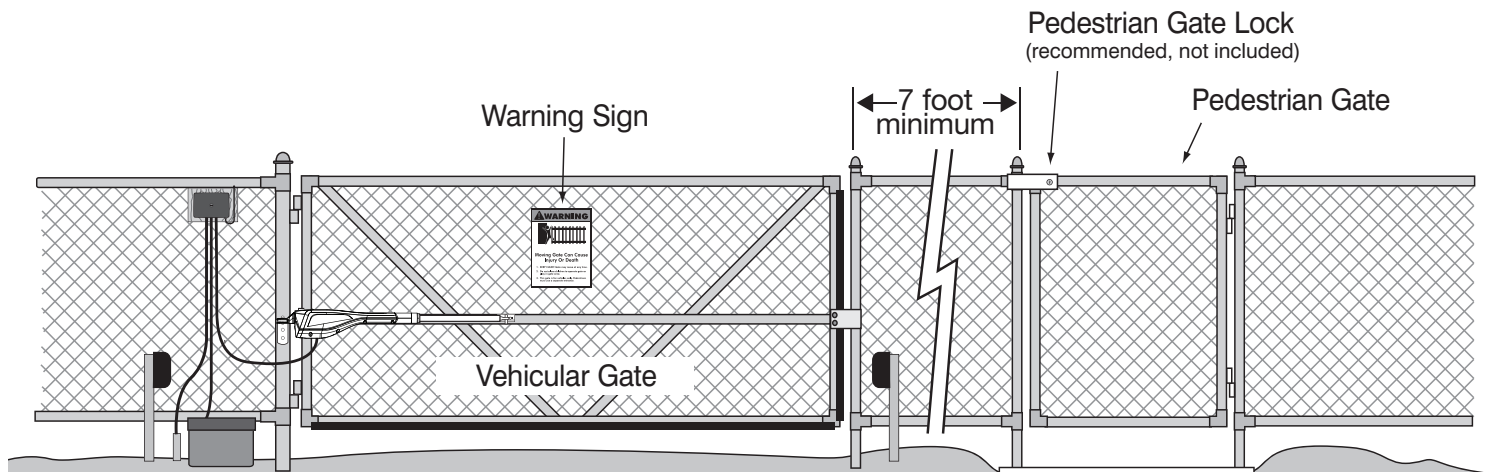

### Warning Signs

The gate operator is provided with 2 safety warning signs. The signs **MUST** be installed on the front and back of the gate where they will be visible in the area of the gate.

Permanently secure each warning sign to the gate.

Immediately replace a damaged, eligible or missing warning sign.

Call Technical Support at 800-543-1236 for a free replacement.



# Important Safety Information

## REQUIRED SAFETY PRECAUTIONS FOR GATES

These warning labels should be found at the locations specified below. If any of them are missing, immediately contact Nortek Security & Control for replacements.

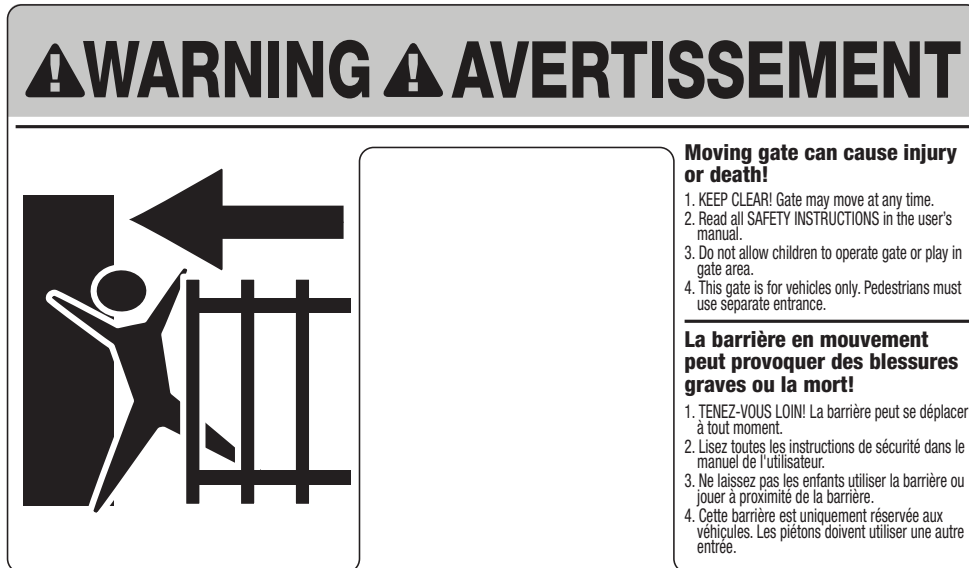

*Labels (1) installed on the front of control box*

# Technical Specifications

## MIGHTY MULE 271 GATE OPENER

### DRIVE

- Low friction screw drive (linear actuator) rated for -5 °F to +160 °F (-20 °C to +71 °C).
- Powered by a 12 V motor with integral gear reducer. Motor speed reduced to 280 rpm.
- Maximum opening arc of 110°. Approximate opening time (90°): 18 seconds, depending on weight of gate.

### POWER

- The system is powered by a 12 Vdc automotive, lawn tractor or marine battery (required but not included).
- Battery charger is on the control board and is maintained by a Mighty Mule 19 VDC output transformer or optional Mighty Mule Solar Panels (10-30 watts).
- **IMPORTANT:** Never use both transformer and solar panel - this will damage the battery and control board.
- One (1) Mini blade-style fuse is rated for 15 A.

**NOTE:** The transformer should not be directly connected to any battery. Do not replace fuses with higher ampere rated fuses; doing so will void your warranty and may damage your control board.

### CONTROL

- Microprocessor-based control board for single leaf, pull-to-open gate installations.
- Learn based digital transmitter technology provides millions of codes for enhanced security.
- RF receiver tuned to 318 MHz.
- Opener length with push-pull tube fully retracted is 26<sup>3</sup>/<sub>8</sub>" , mounting point to mounting point. Maximum stroke is 13".
- Adjustable auto-close timer (OFF, 3 to 120 seconds), and Dual Sense Technology™ Stall Force.
- Power terminal block accommodates an (included) transformer or optional solar panels.
- Accessory terminal block fully compatible with all Mighty Mule access controls.
- Control board allows connection of edge sensors and photoelectric sensors.
- Audio entrapment alarm sounds if unit encounters an obstruction twice while opening or closing.

### OPERATIONAL CAPACITY

- Maximum gate size: 300 lbs., 12' long.

**NOTE:** BALL BEARING HINGES SHOULD BE USED ON ALL GATES WEIGHING OVER 250 LB.

# Before You Begin

## POWERING OPTIONS

### 1. Determine Charging Option for Battery: Transformer OR Solar

**NEVER USE TRANSFORMER AND SOLAR PANEL(S) AT THE SAME TIME. It will damage the control board.**

#### IMPORTANT:

- The Mighty Mule gate operator is designed and intended for use with a 12 Volt automotive or marine type battery. The battery must be placed inside a weatherproof case and located within 6 feet from the Control Box. The 8 foot harness supplied connects the battery to the Control Box.
- The transformer is designed for indoor use. If the transformer can be plugged only into an outside electrical outlet, a weatherproof cover/housing (available at local electrical supply stores) must be used.
- If your gate is more than 1000 ft. from an AC power source, you will need to use at least 10 watt solar charging power to charge the battery [FM123]. Refer to the Solar Panel and Gate Activity chart below.
- All low voltage wire used with the Mighty Mule gate operator must be 16 gauge dual conductor, stranded, direct burial wire [RB509]. Do not run more than 1000 ft. of wire.

## SOLAR PANEL AND GATE ACTIVITY CHART

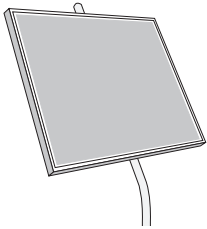

The table and map illustrate the maximum number of gate cycles to expect per day in a particular area when using from 10 to 30 watts of solar charging

power prior to the battery depleting to a state where the unit will not function. The figures shown are for winter (minimum sunlight). Accessories connected to your system will draw additional power from the battery.

**NOTE:** UP to 250 ft. of dual conductor, 16 gauge, multi-stranded wire may be used to allow installation of solar panels in direct sunlight.

10 Watt Solar Panel [FM123]

Deep cycle marine battery is recommended for solar and/or high traffic applications.

Single Gate Winter Ratings	Zone 1	Zone 2	Zone 3
12 v single gate (10 watts) solar charger	8	16	26
12 v single gate (20 watts) solar charger	14	28	38
12 v single gate (30 watts) solar charger	20	44	54

\* Power increments are for reference only.

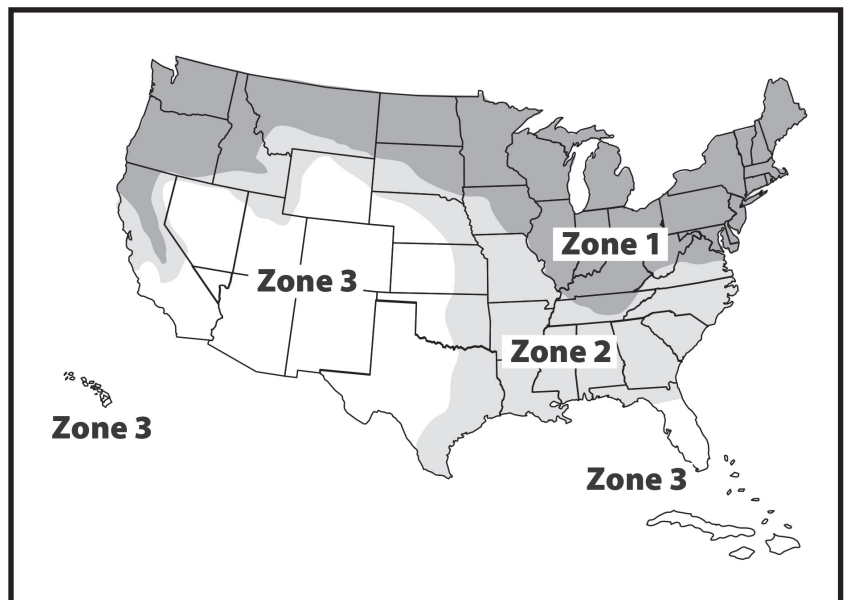

## CHECK EXISTING GATE SIZE AND MATERIAL

- Gate size: Up to 12 feet and up to 300 lbs
- Type of gate material: Vinyl, aluminum, chain link, farm tube, wrought iron, wood.
- ⚠ Not rated for use on solid surface gates.

## IMPORTANT: CHECK FOR PROPER GATE INSTALLATION

- The gate must be plumb, level, and swing freely on its hinges.
- The gate must move throughout its arc without binding or dragging on the ground.
- Wheels must NOT be attached to the gate.
- Gates over 250 lb. should have ball bearing hinges with grease fittings.
- Post must be secured in the ground with concrete (minimizes twist/flex when the operator is activated).
- Make sure there is a stable area for mounting the gate bracket (this may require the addition of a horizontal or vertical cross member).
- We recommend you position the operator near the center-line of the gate to keep the gate from twisting and flexing, and to avoid back-splash from rain.

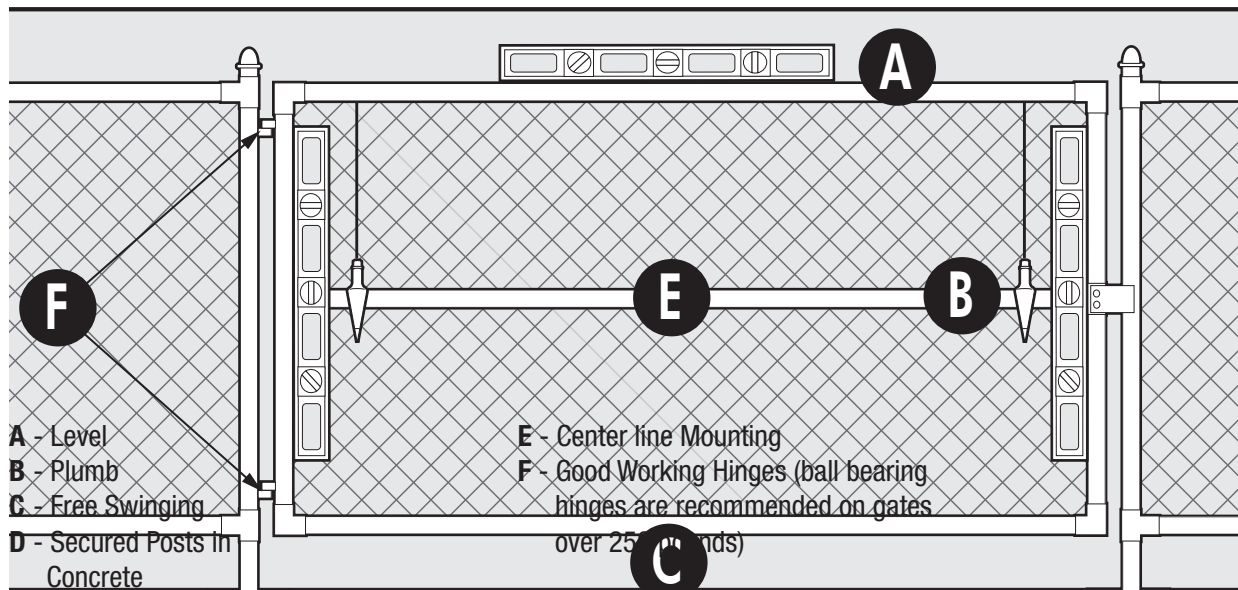

## Gate Grounding

- For reference only.

### Cooper Clad Ground Rod (not included)

Use an 8 foot, 5/8 inch ground rod, positioned two feet or less from the post and 2 inches or less above the ground. Available at local home center or hardware stores.

**NOTE:** No grounding system absolutely protects against lightning strikes. If installed correctly, a grounding system will help minimize damage to your gate operator.

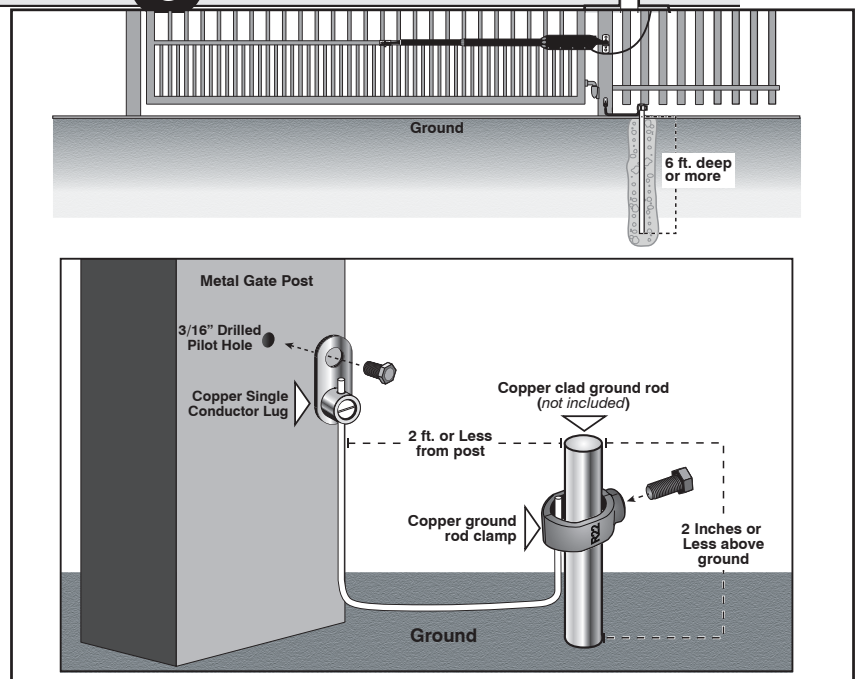



# ITEMS INCLUDED

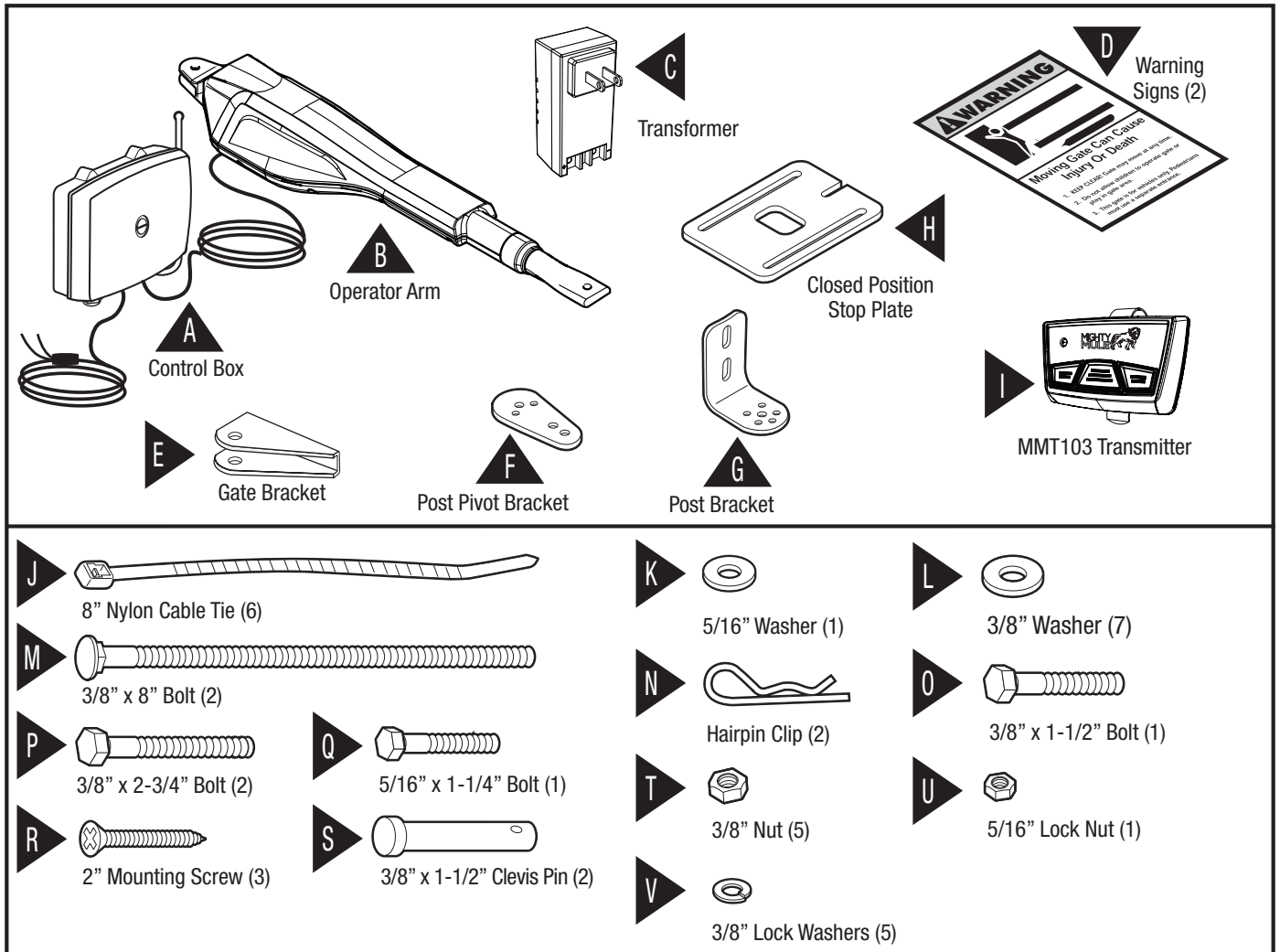

## TOOLS NEEDED

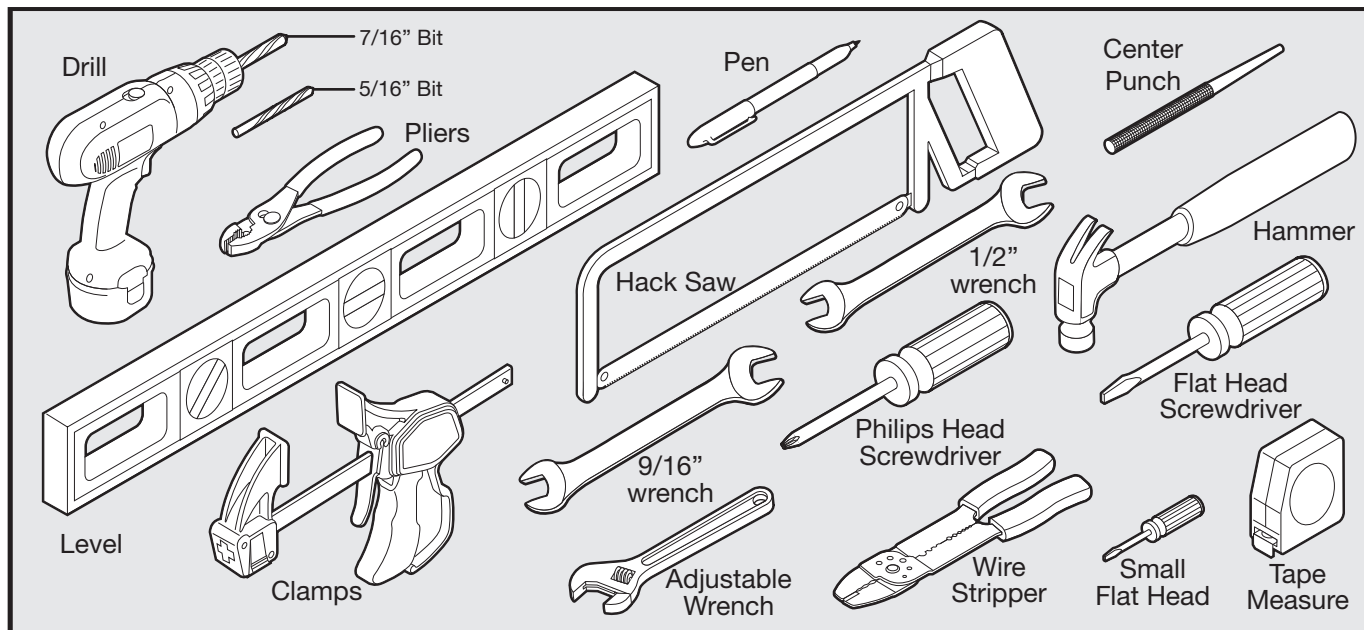

## ITEMS NOT INCLUDED

- 12 Volt automotive or marine battery and a weather proof case.
- Low voltage wire will be needed to run from the transformer to the control box; length depends upon the distance between the transformer power supply and the control box. See **Transformer Wiring Installation** on page [19](#), and the accessory catalog.
- PVC conduit.
- If your gate is more than 1000' away from an AC power source you will need to use at least one Mighty Mule solar panel to trickle charge the battery. See the accessory catalog (Do not use both transformer and solar).
- If you have thin-walled tube or panel gates, see Recommended Reinforcement Examples after Step 3 of "Mounting Operator to Gate".
- Depending on the type of gate, a horizontal cross member or mounting plate may be needed to mount the front of the operator and gate bracket to the gate. See Gate Bracket Mounting Examples after Step 3 of "Gate Operator Installation."
- Surge protection for transformer.
- Some types of installations require u-bolts.
- Additional washers or a metal plate may be needed for wooden post.
- Weatherproof cover for outdoor outlet and transformer.
- If the post is larger than 6", bolts longer than 8" are needed.

# Installation

## GATE OPERATOR INSTALLATION

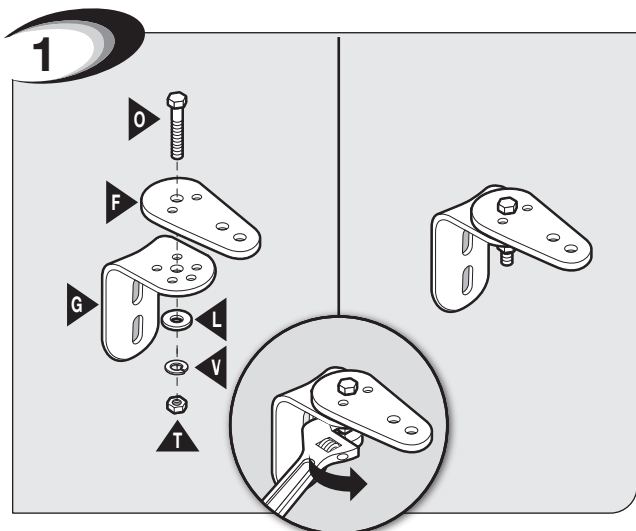

Assemble post bracket parts. Do not completely tighten during this step.

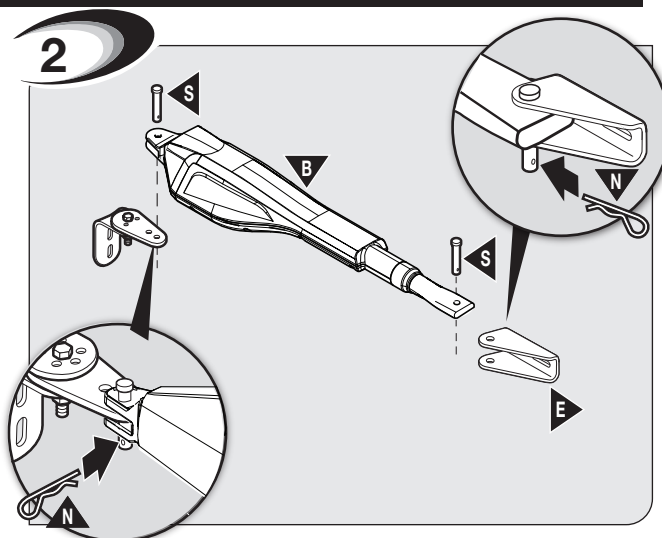

Attach operator (in fully retracted position) to gate and post bracket and secure with required hardware.

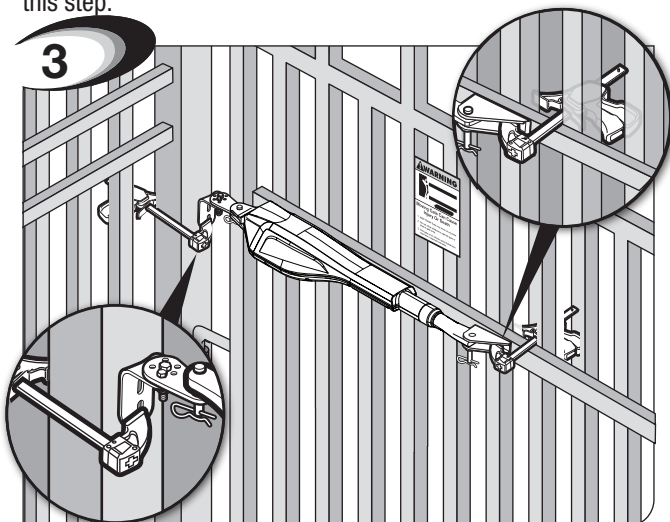

With Gate in OPEN position, using clamps, secure operator to gate post and center cross member of gate.

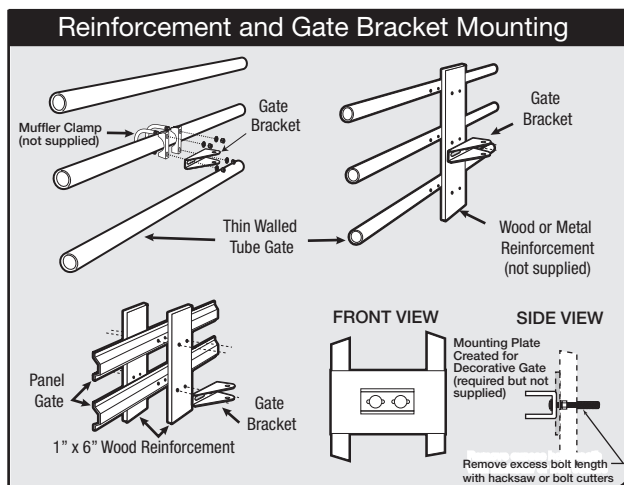

Recommended reinforcement and gate bracket mounting examples.

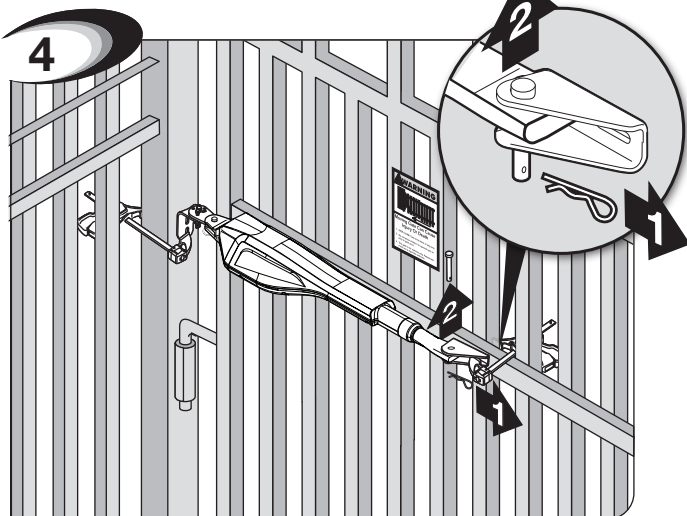

Remove clevis pin from the gate bracket and support loose operator.

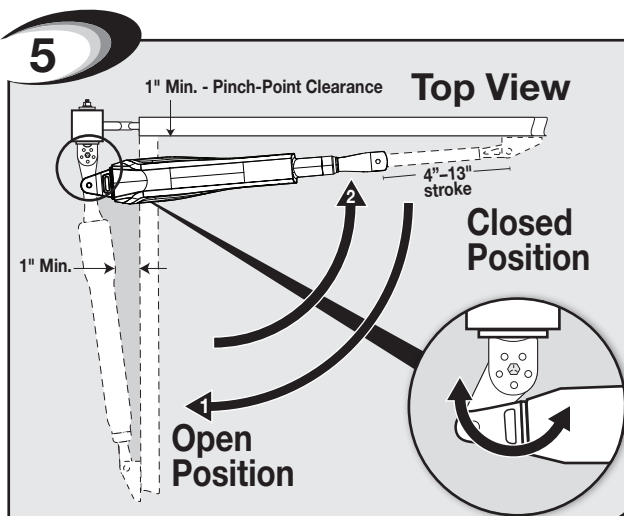

Swing gate and operator arm to the CLOSED position-check clearance/binding by inspecting alignment. Arm stroke should be a maximum of 13". *TIP: Turning the pivot bracket over gives more hole alignment options for the post pivot bracket assembly.*

# GATE OPERATOR INSTALLATION

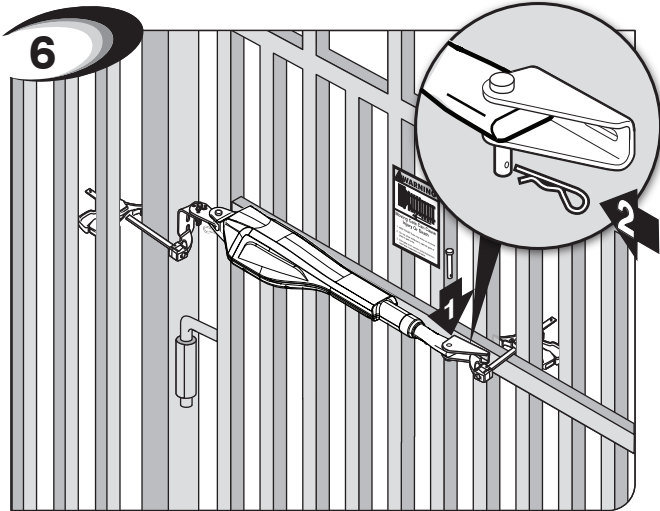

6  
OPEN gate and reattach operator with clevis pin. Check to ensure the operator is level.

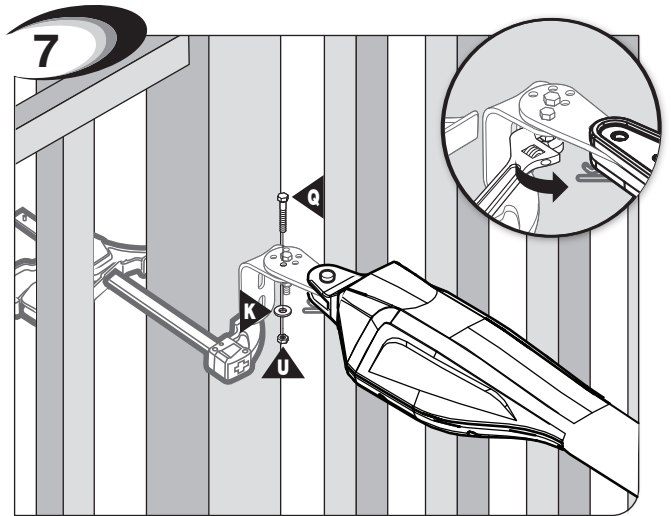

7  
Secure post pivot bracket to post bracket with the hardware provided (Q,K,U) when you have achieved the 1" clearance shown in Step 5 in both open and closed positions.

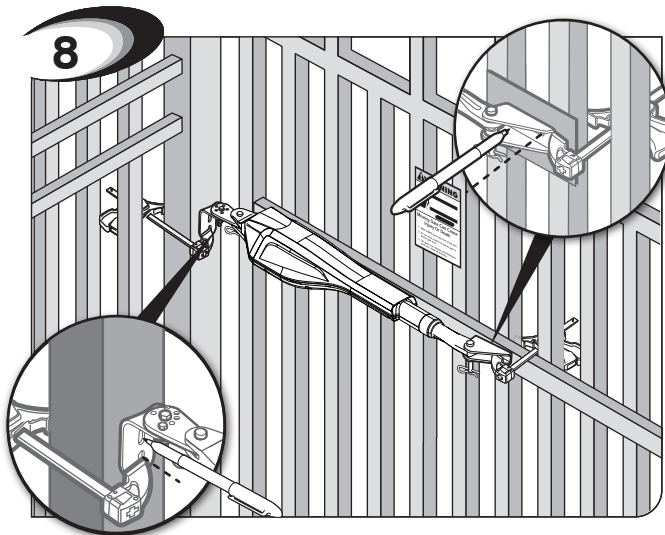

8  
Mark middle of post bracket slots on fence post. Mark middle of gate bracket slots on gate cross support.

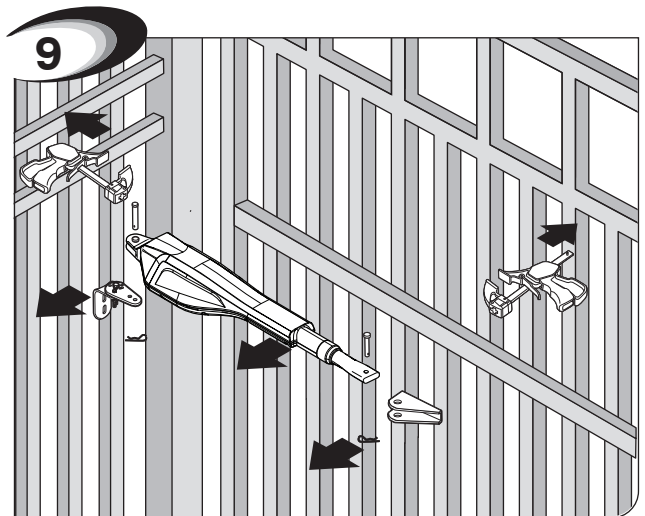

9  
Remove clamps, post bracket, gate bracket, and operator. Then use a hammer and center punch to mark hole positions.

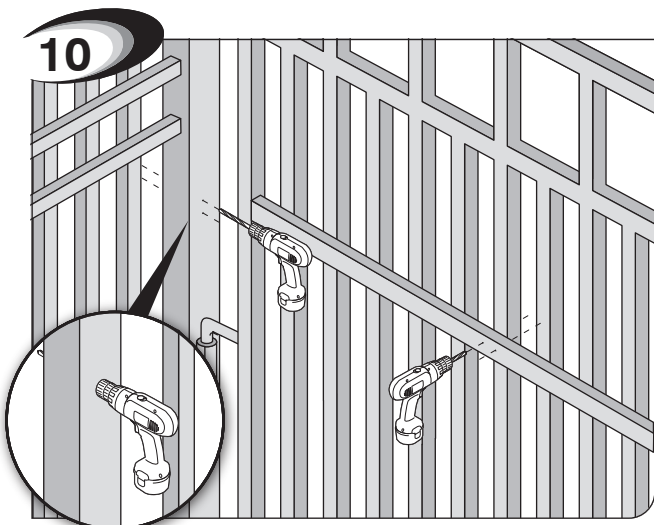

10  
Drill holes completely through gate post and gate cross support.

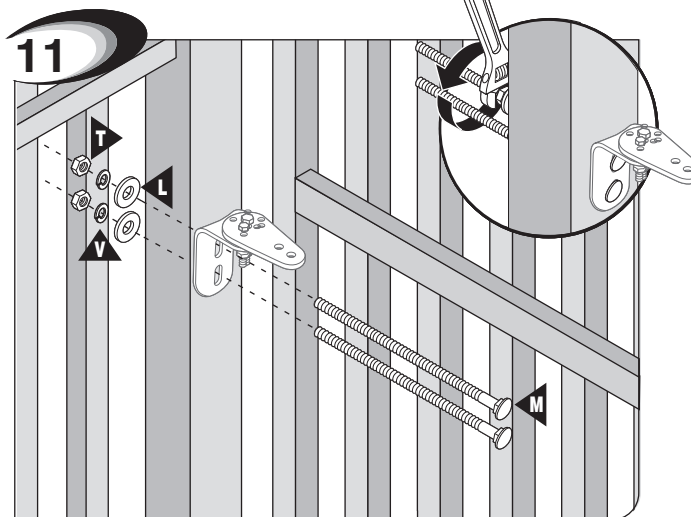

11  
Attach post bracket assembly to gate post. NOTE: Must be through bolted.

## GATE OPERATOR INSTALLATION

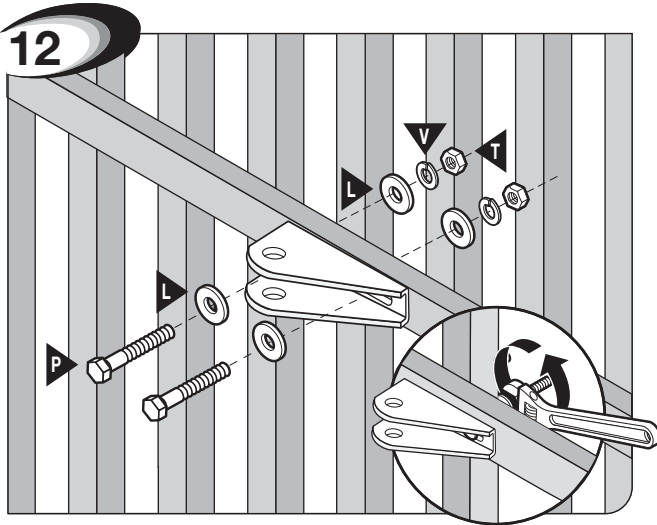

Attach gate bracket assembly to gate cross support.

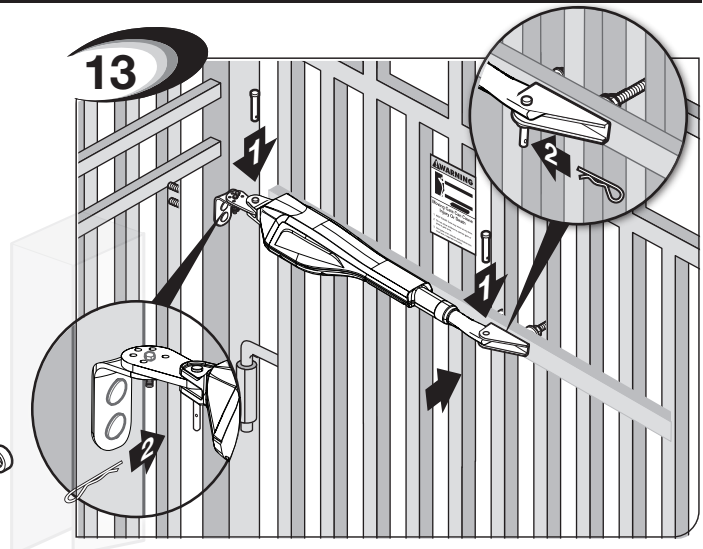

Attach and secure operator assembly to brackets.

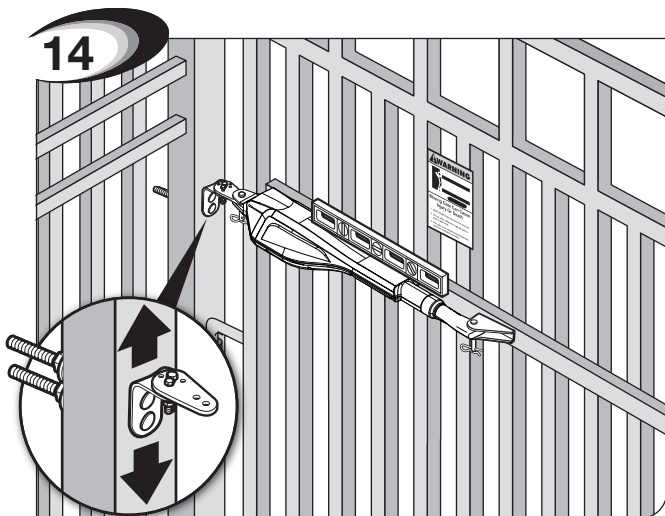

Check for level. Adjust post bracket if necessary.

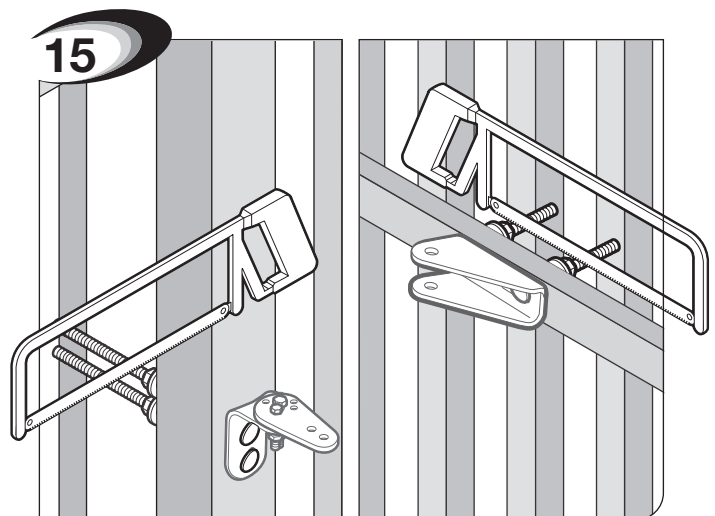

Tighten all bolts and remove excess length on post and gate bracket bolts with hacksaw.

## CLOSED POSITION STOP PLATE INSTALLATION

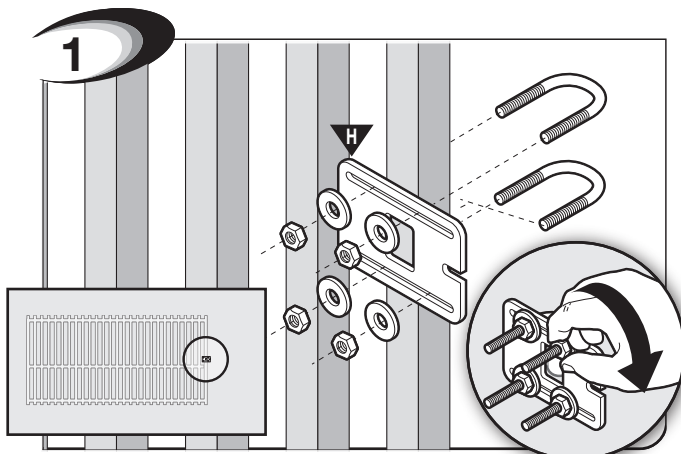

Remove the arm from the front bracket then attach closed position stop plate to the leading edge of the gate with one of the following:

- U-bolts—tube and chain link gates (Not included)
- Wood/lag screws—flat aluminum/wood supports (Not included).

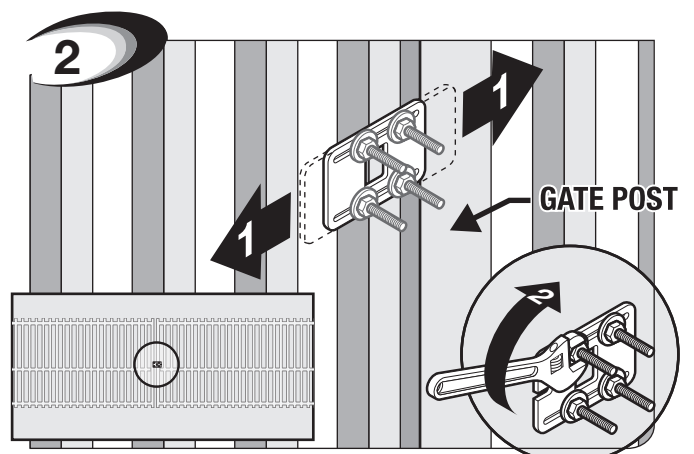

Position gate stop with gate CLOSED to fence post. Tighten fasteners. Cut off excess bolt length.

# CONTROL BOX & BATTERY INSTALLATION

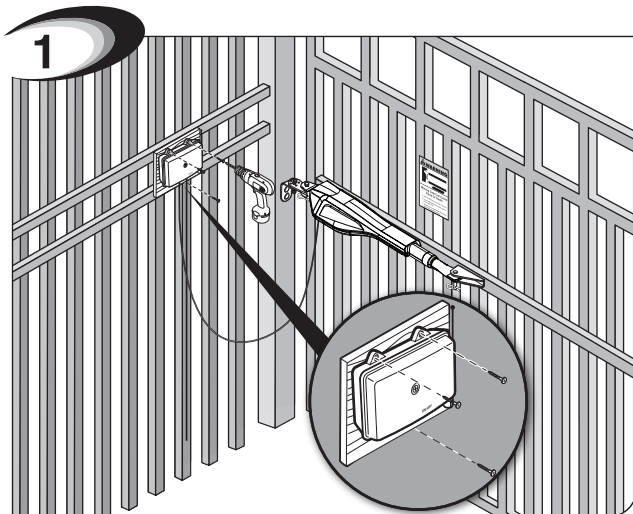

1 Mount control box on piece of treated plywood then attach it to post or fence using screws.

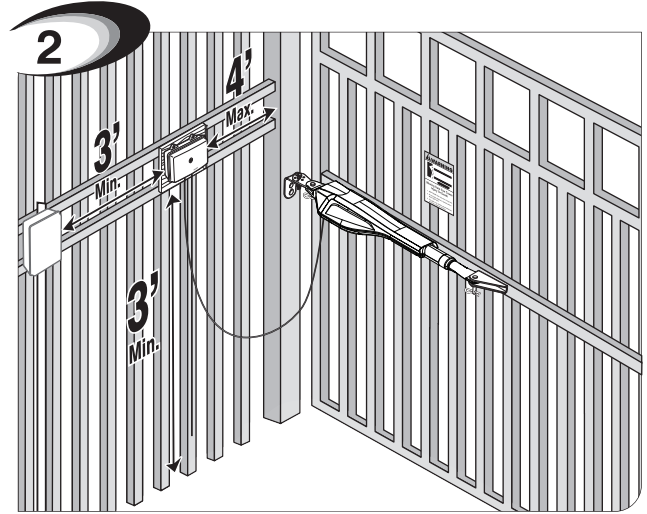

2 Locate control box mounting area. **IMPORTANT:** Be sure to mount box at least 3 feet from AC power and 3 feet off the ground.

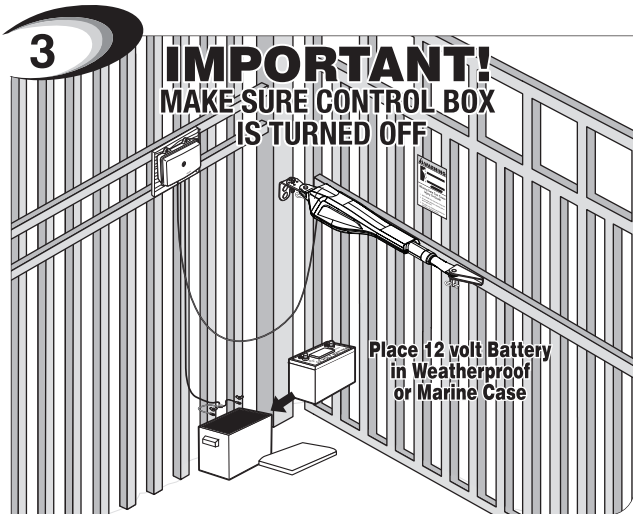

3 **IMPORTANT! MAKE SURE CONTROL BOX IS TURNED OFF**. Place 12 volt battery and weatherproof battery box within 6 feet of the control box Attach the battery harness wires from the control box to the battery terminals.

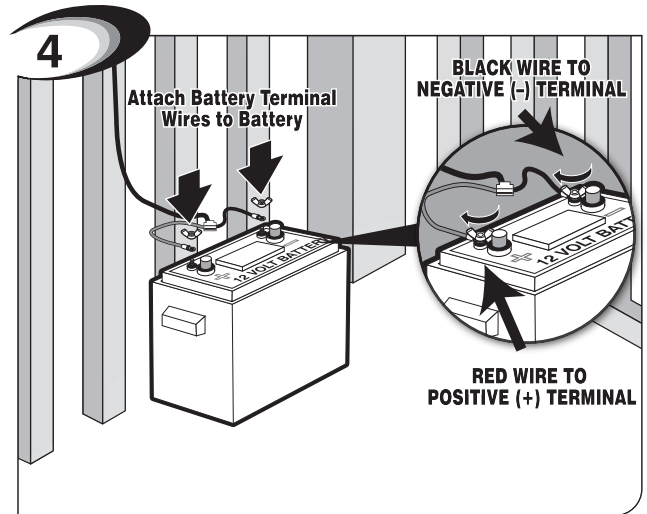

4 Tighten the bolts, washers, and nuts and place the cover on the weatherproof box. **IMPORTANT:** Do not connect the transformer or solar panel directly to the battery.

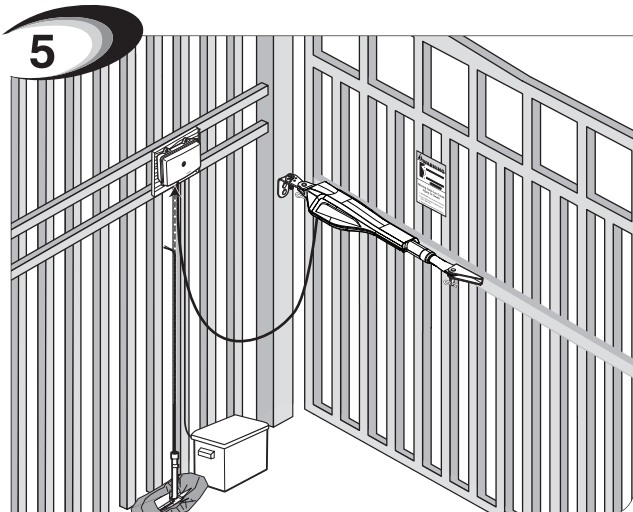

5 Use PVC conduit from ground up to control box.

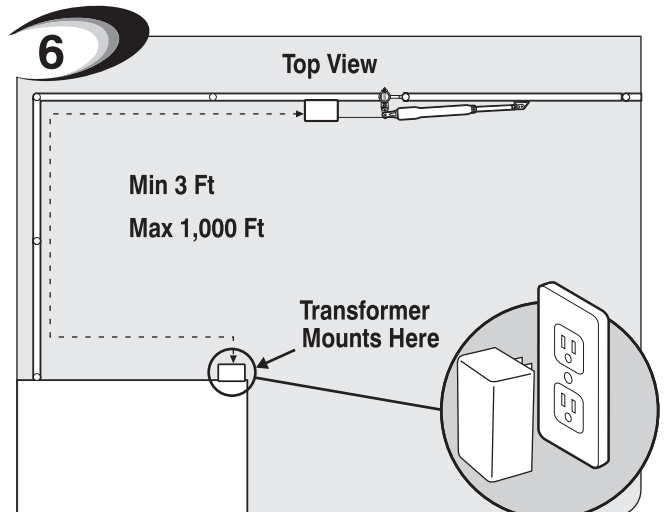

6 Locate power outlet and identify wire path to control box. **NOTE:** If OUTLET is OUTSIDE use weatherproof cover. Inspect the wire to insure the prevention of damage.

# TRANSFORMER WIRING INSTALLATION

NOTE: If using a solar panel charging kit, go to [page 20](#).

## ⚠ WARNING

Before digging contact local authorities to locate underground utilities such as electric and gas service.

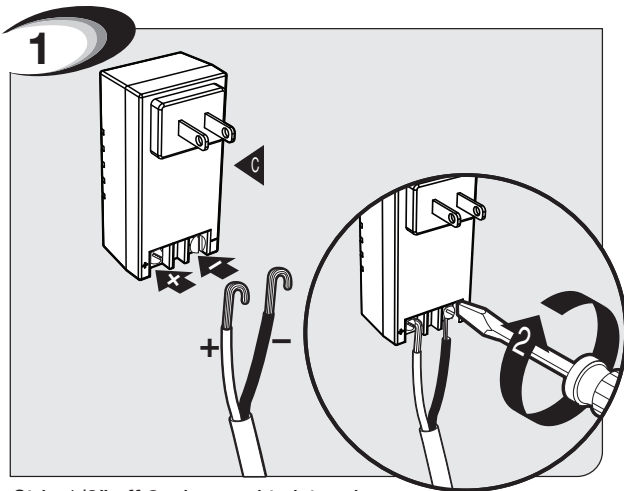

Strip 1/2" off 2 wires and twist ends.  
**IMPORTANT:** Attach red wire to left (+) screw terminal. Attach black wire to right (-) screw terminal.

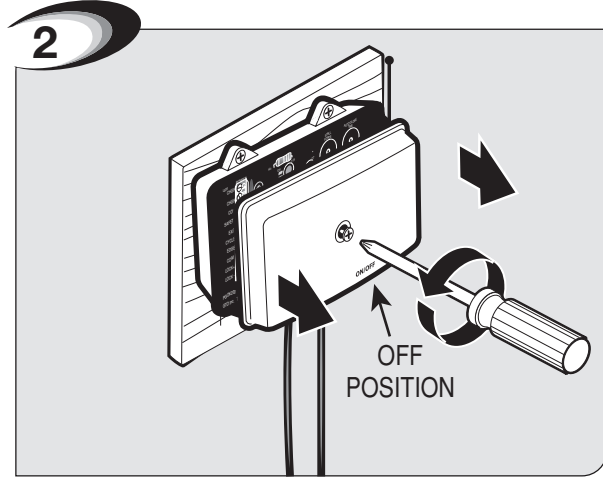

With the Control Panel OFF, remove control panel cover by unscrewing center cover fastener.

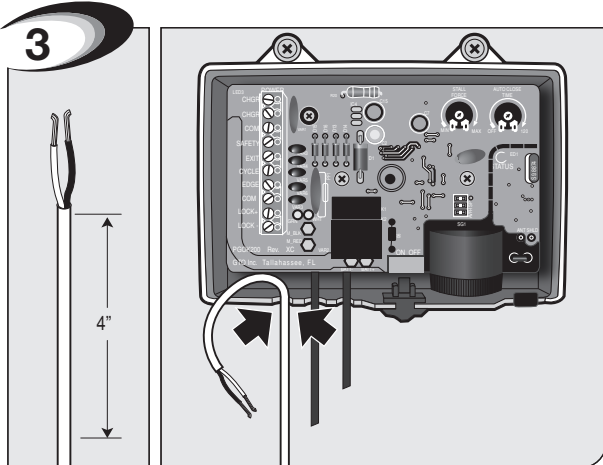

Feed 4" of low voltage wire through strain relief into box with battery wire harness. **IMPORTANT:** Antenna must point straight up.

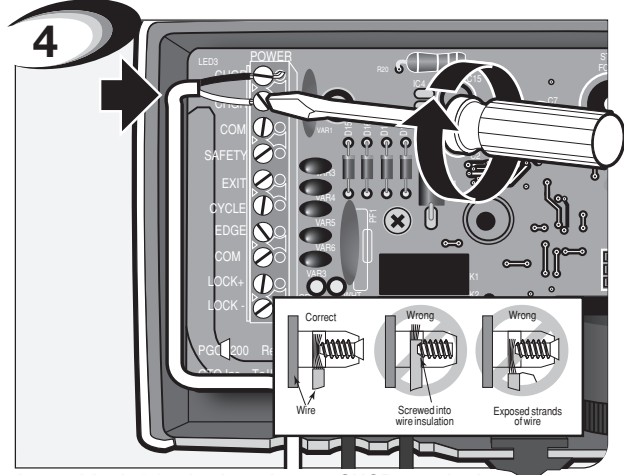

Insert black (-) wire into the top CHGR terminal.  
Insert the red (+) wire into the 2ND CHGR terminal.

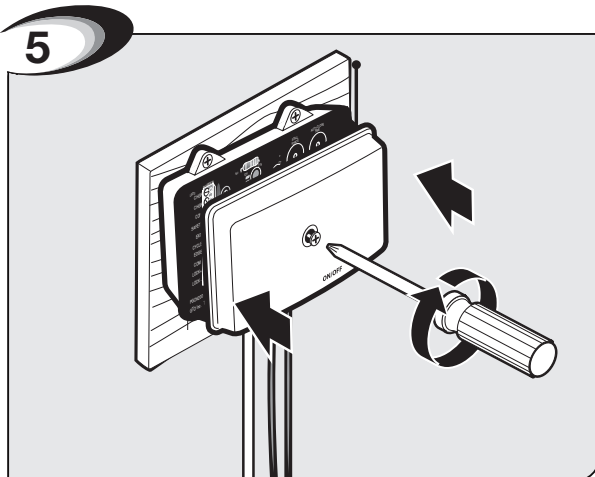

Attach cover back onto the control box.

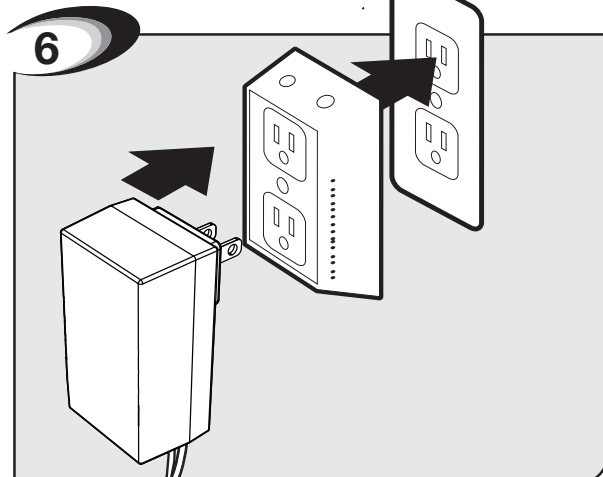

Plug in transformer to power outlet. (Use of a surge protector is highly recommended. If outdoors use weatherproof box.)

# SOLAR PANEL INSTALLATION

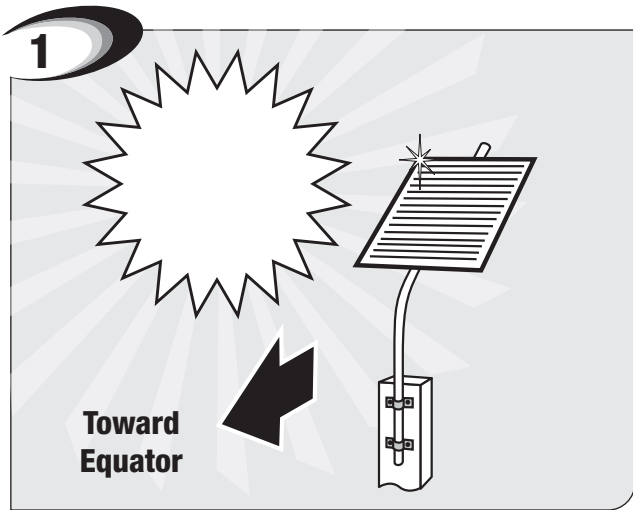

Position solar panel facing sun and in a non-shaded open area that allows 8 hours of direct sunlight for a full charge.

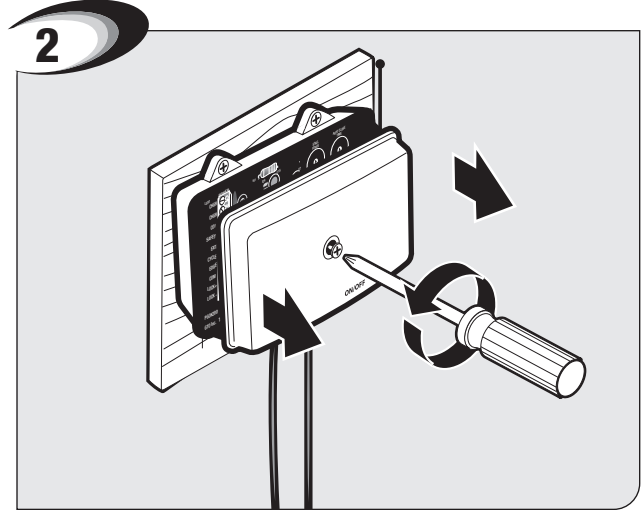

With the Control Panel OFF, remove control panel cover by unscrewing center cover fastener.

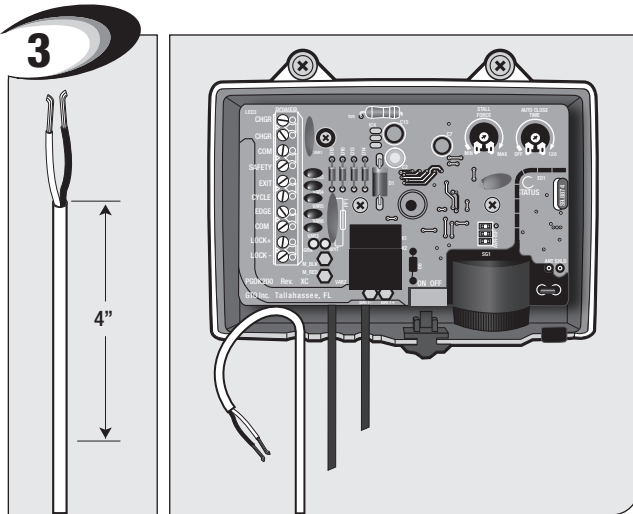

Feed 4" of the solar panel wire through strain relief into control box.

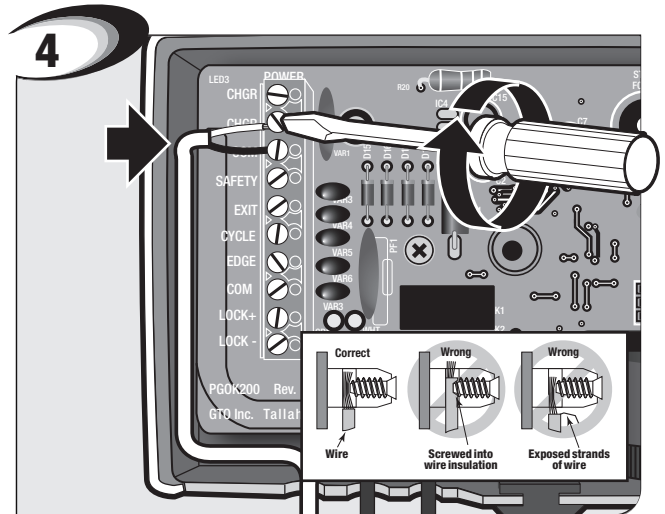

**IMPORTANT:** Insert red (+) wire into the top CHGR terminal and the black (-) wire into the COM terminal.

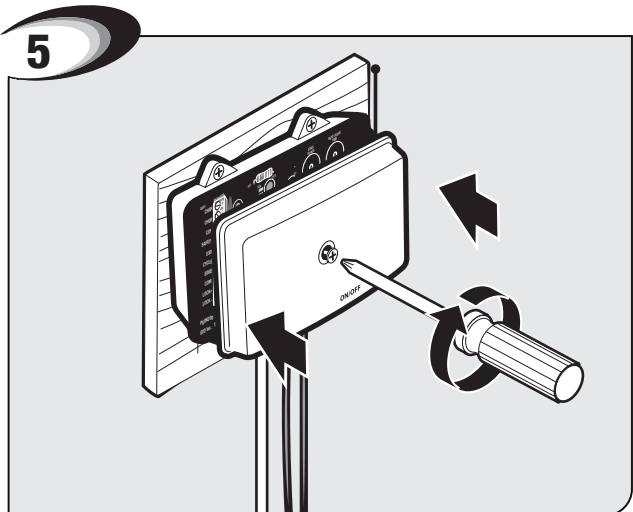

Reattach cover. Turn power on.

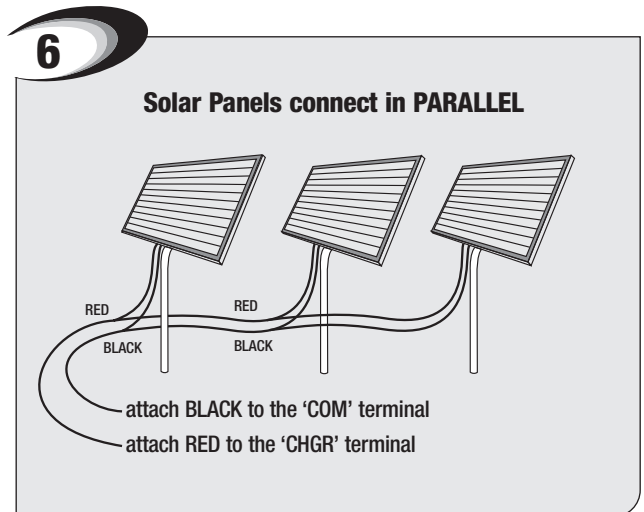

For multiple solar panels, wire the panels in parallel as shown.



# TRANSMITTER PROGRAMMING

## Programming a MMT103 Transmitter.

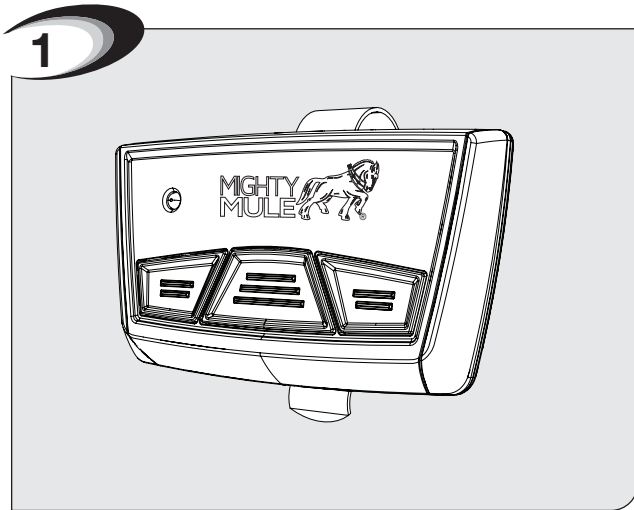

Take hold of your transmitter.

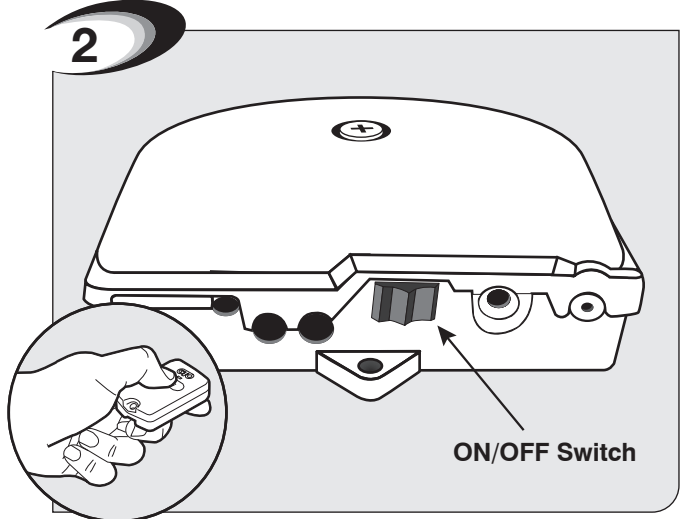

Turn off control box. Press and hold a preferred transmitter button while sliding the ON/OFF switch to the ON position. Continue to hold transmitter button for 8 - 10 seconds. You will hear a single or a series of beeps, followed by a pause then a single beep. Release transmitter's button. Your personal code is now programmed. **NOTE:** The button you chose will be the button used to operate your system.

1. **Adding additional MMT103 transmitters** - Repeat the above process for up to a total of 20 transmitters.
2. **Erasing an individual MMT103 transmitter** - Repeat the above programming process to erase/delete a transmitter. **NOTE:** This will only happen if the arm is NOT fully retracted.
3. **Erase all** - this process will erase all transmitters.
  - a. Press and hold down the button on a programmed transmitter.
  - b. Turn the unit off while holding down the button on the transmitter.
  - c. Continue to hold down the button for at least 10 seconds. The status LED will flash and then illuminate solid. This indicates the Erase All procedure has completed.
4. **Program the FM135 type transmitter** (see **Programming an FM135/134 Dip Switch Style Transmitter**, next page).

## IMPORTANT

The process for programming any wireless accessory in the same process as erasing that accessory. There is no indication that the accessory has been programmed or erased. Make sure to test the accessory before programming, because you may unintentionally erase it.

# TRANSMITTER PROGRAMMING

## Programming an FM135 Transmitter

All Mighty Mule transmitters are set to a standard code at the factory. However, for your safety and security, we **strongly recommend** that you replace the factory setting with your own personal code. Follow the directions below:

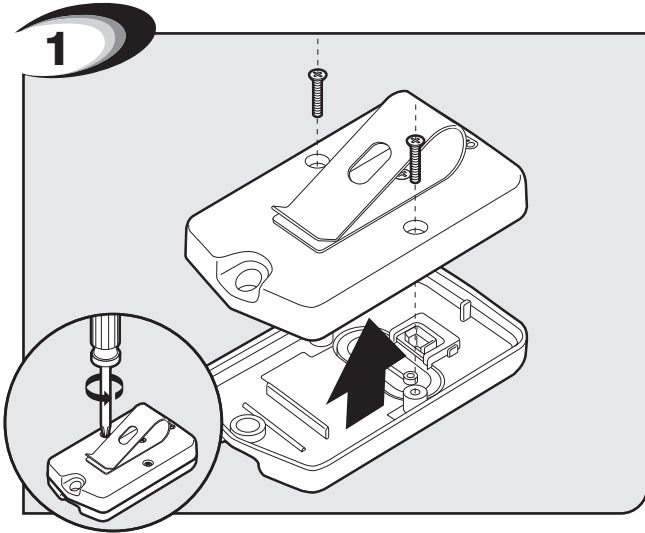

Remove back cover of the opener remote.

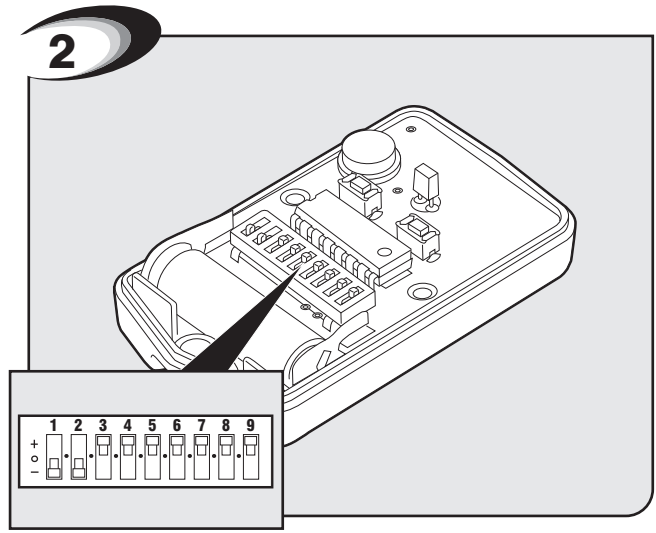

Flip opener remote over. Use small screwdriver to move switches to random positions. If you have more than one transmitter, now is a good time to set them all with the same code.

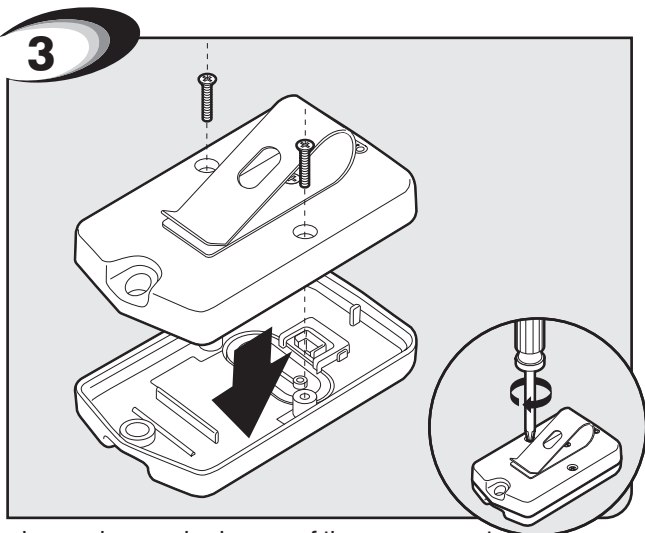

Replace and secure back cover of the opener remote.

**NOTE:** The process for programming any wireless accessory in the same process as erasing that accessory. There is no indication that the accessory has been programmed or erased. Make sure to test the accessory before programing, because you may unintentionally erase it.

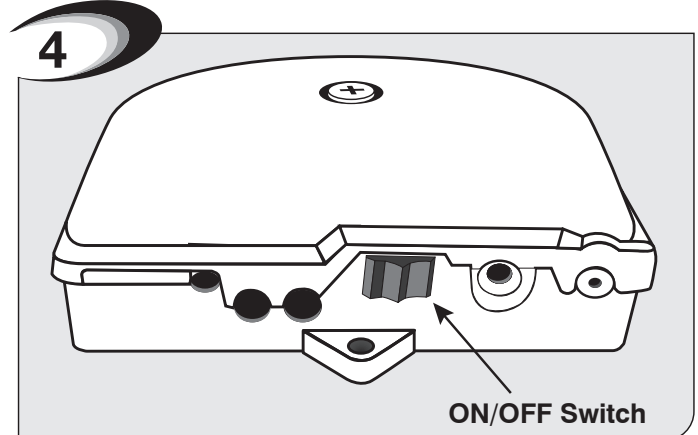

Turn off control box. Press and hold a transmitter button while sliding the ON/OFF switch to the ON position. Continue to hold transmitter button for 8 - 10 seconds. You will hear a single or a series of beeps, followed by a pause then a single beep. Release transmitter's button. Your personal code is now programmed. **NOTE:** The button you chose will be the button used to operate your system.

- An infinite number of the transmitters can be used, provided that the dip switches are set to match one another.

**WARNING:** Changes, modifications or adjustments not expressly approved by Nortek Security & Control, LLC could void the user's authority to operate this equipment. There Are No User Serviceable Parts.

**NOTICE:** This equipment has been tested and found to comply with the limits for a Class B digital device, pursuant to part 15 the FCC. These limits are designed to provide reasonable protection against harmful interference in a residential installation. This equipment generates, uses and can radiate radio frequency energy and, if not installed and used in accordance with the instructions, may cause harmful interference to radio communications. However, there is no guarantee that interference will not occur in a particular installation. If this equipment does cause harmful interference to radio or television reception, which can be determined by turning the equipment off and on, the user is encouraged to try to correct the interference by one or more of the following measures:

- Reorient or relocate the receiving antenna.
- Increase the separation between the equipment and receiver.
- Connect the equipment into an outlet on a circuit different from that to which the receiver is connected.
- Consult the dealer or an experienced radio/TV technician for help.

This device complies with Part 15 of the FCC Rules. Operation is subject to the following two conditions: (1) This device may not cause harmful interference, and (2) this device must accept any interference received, including interference that may cause undesired operation.

## SETTING CLOSED LIMIT POSITION

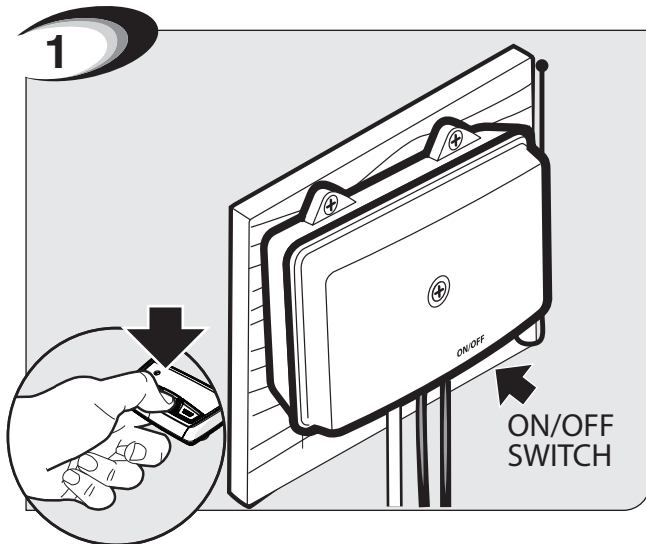

With gate in the open position, (arm retracted) turn the control box ON/OFF switch to the off position. Press and hold the transmitter while sliding the ON/OFF switch to the ON position and you will hear a single or a series of beeps followed by a pause then a single beep. At that point release the transmitter button. This process may take 8 - 10 seconds.

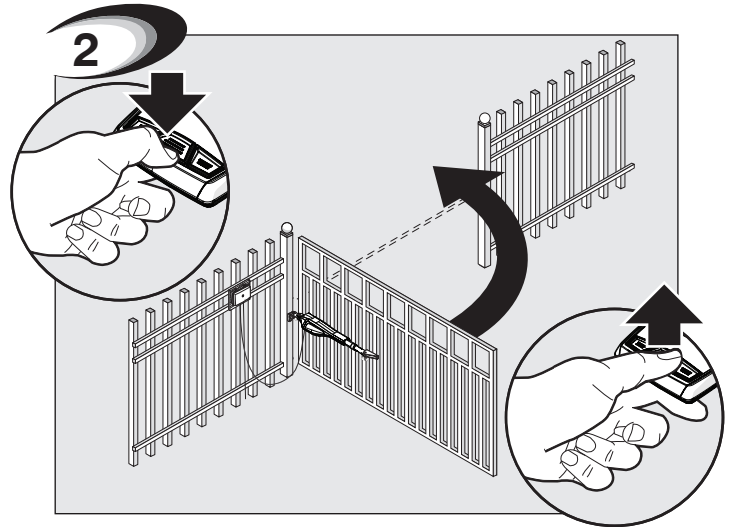

Press and release the learned transmitter button; gate should start closing. When the gate reaches the desired CLOSED position, press and release the transmitter button again.

**NOTE:** If your gate stops and reverses before it fully closes, you may need to increase the stall force (see page 24). If you make changes to stall force, you'll need to Step 1 and repeat the process.

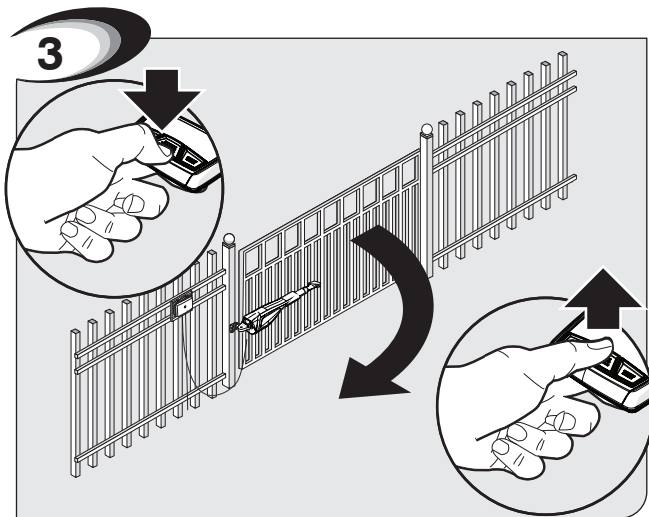

Press and release the transmitter button again; gate should start opening. Once the gate reaches the OPEN position, a single audible alarm will sound to indicate the limit is set.

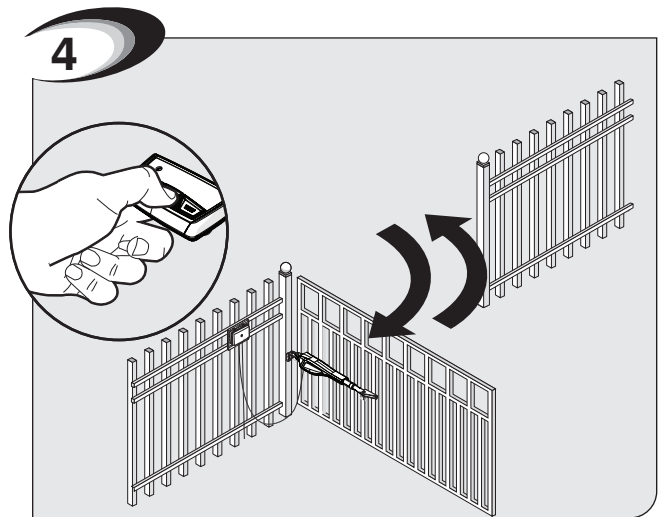

Gate operator's closed position is now set. Press and release transmitter to close gate for normal operation.

# SETTING DUAL SENSE DETECTION & AUTO CLOSE TIMER

1

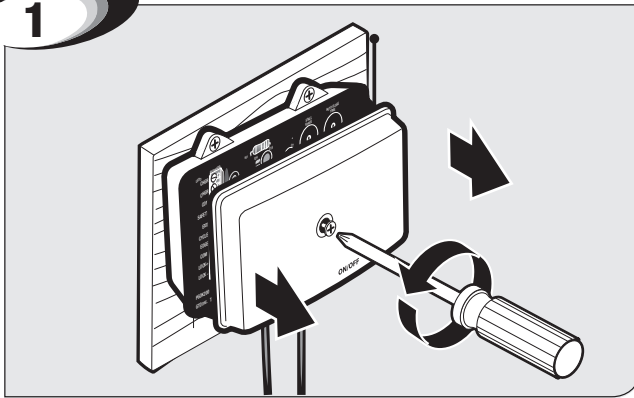

With the Control Panel OFF, remove control panel cover by unscrewing center cover fastener.

2

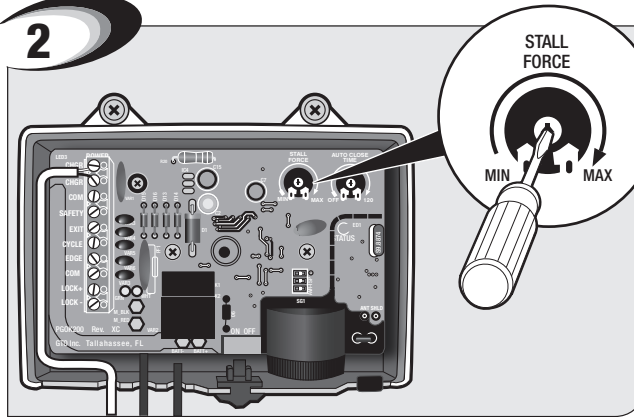

Do not use the Dual Sense Stall Force adjustment to compensate for a gate that is sticking or binding.

**!** Excessive Stall Force may cause damage to the gate operator, gate system, Bodily Injury or Death.

The Stall Force adjustment controls the amount of force the operator will apply against an obstruction before it stops and reverses direction. The adjustment on the control board operates like a volume control on a radio. It controls the amount of force the operator will apply to an obstruction before it automatically reverses direction.

The Stall Force adjustment is located on the control board. Turn the "STALL FORCE" arrow in the center of the potentiometer with small flat head screwdriver. Adjust the sensitivity to the point where the gate operates without obstructing from its own weight or the wind conditions in your area.

## CAUTION

For safety reason the Dual Sense Stall Force setting on the Mighty Mule control board comes from the factory set at set at the 10 o'clock position. This setting may need adjustment depending on the size and weight of the gate.  
**ALWAYS KEEP SAFETY AT THE TOP OF YOUR LIST WHEN ADJUSTING OR SERVICING YOUR GATE SYSTEM.**

You may need to increase the stall force in cold weather due to increased resistance from gate hinges. However, the adjustment must remain as near to minimum as possible and when the weather improves decrease the setting to the appropriate position.

**NOTE:** The stall force setting must at the lowest (minimum) possible position.

3

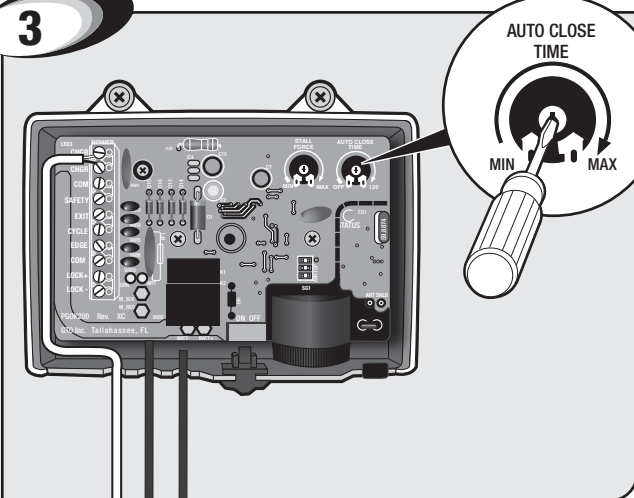

Turn the "AUTO CLOSE TIME" arrow in the center of the potentiometer with small flat head screwdriver to determine how long the gate will remain open before it automatically closes. The limits are OFF and 3 - 120 seconds. The factory setting is OFF.

4

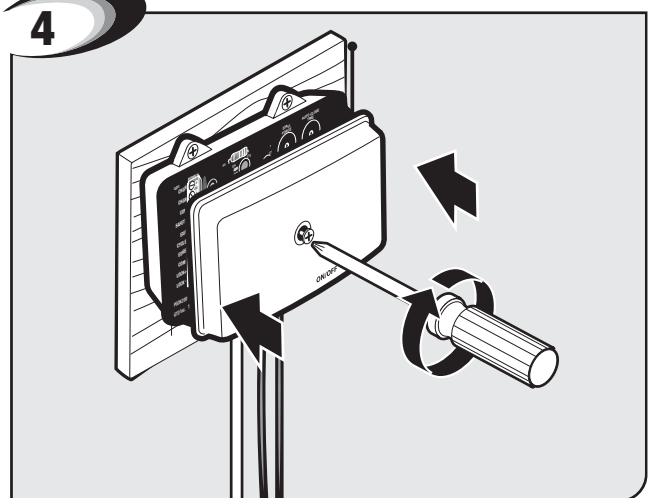

Close control box, unless you are adding additional accessories. If adding additional accessories, see next page.

## CONNECTING ADDITIONAL DEVICES

Mighty Mule strongly recommends the use of additional obstruction detection devices. However, we do not endorse any specific brand names. Only use products that are listed to be in compliance with any applicable UL safety standards and national and regional codes.

**PLEASE NOTE: Contact sensors, non-contact sensors, shadow loops, etc. are not included with the Mighty Mule. Refer to the sensor manufacturer's instructions for information about installing accessory devices.**

The Mighty Mule ONLY accepts accessory devices with normally open dry contact outputs.

### **⚠ WARNING**

Make sure the operator power switch is turned OFF before connecting ANY device wiring to the terminals of the controller. Unplugging the transformer does not turn power to the operator off.

### Wiring Accessories through Control Board Wiring Knockout

Remove control box cover.

Carefully remove wiring knockout (on cover) to insert accessory wires.

Insert accessory wires through the knockout and route to the accessory input terminals on the control board.  
(See pg. 26)

Reattach control box cover.

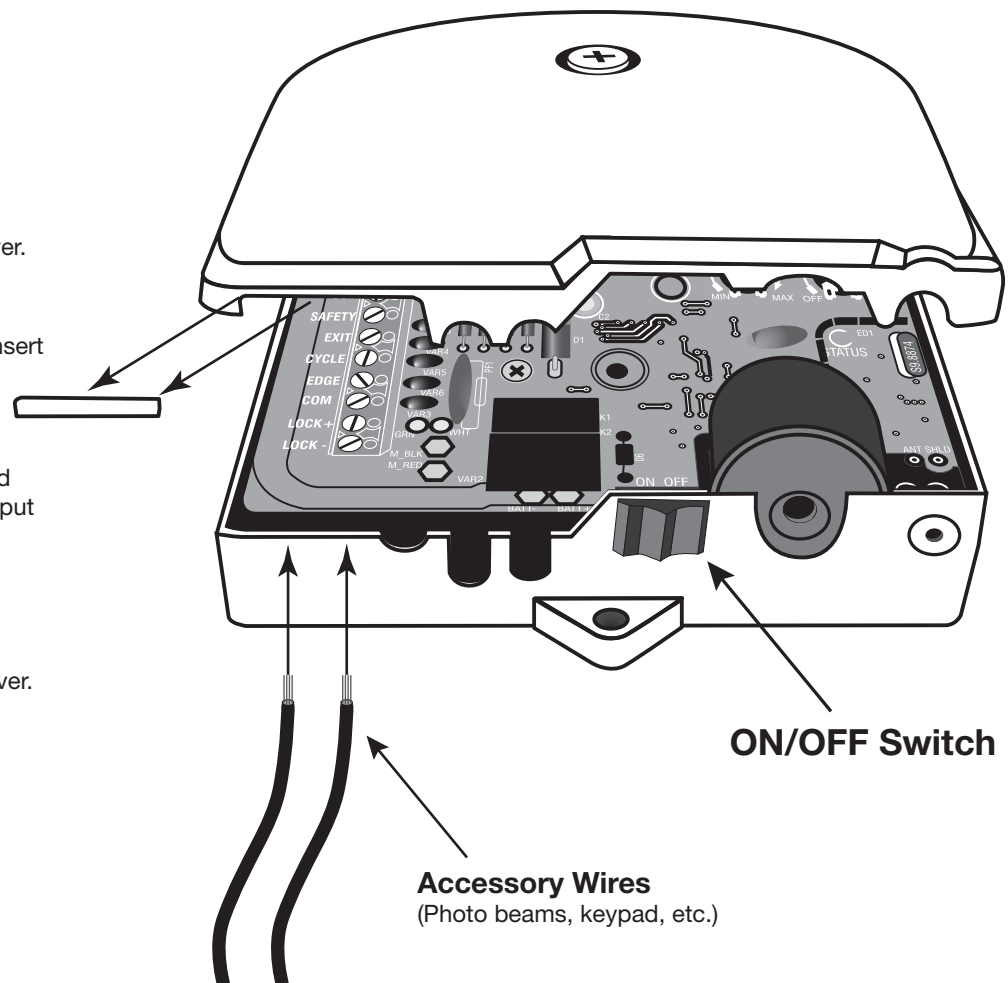

# CONTROL BOARD CONNECTIONS

## NOTES:

- All accessory inputs are dry-contact, normally open, inputs. **DO NOT** apply external voltage sources to these inputs.
- All accessory inputs are connected with respect to **COMMON** terminal.

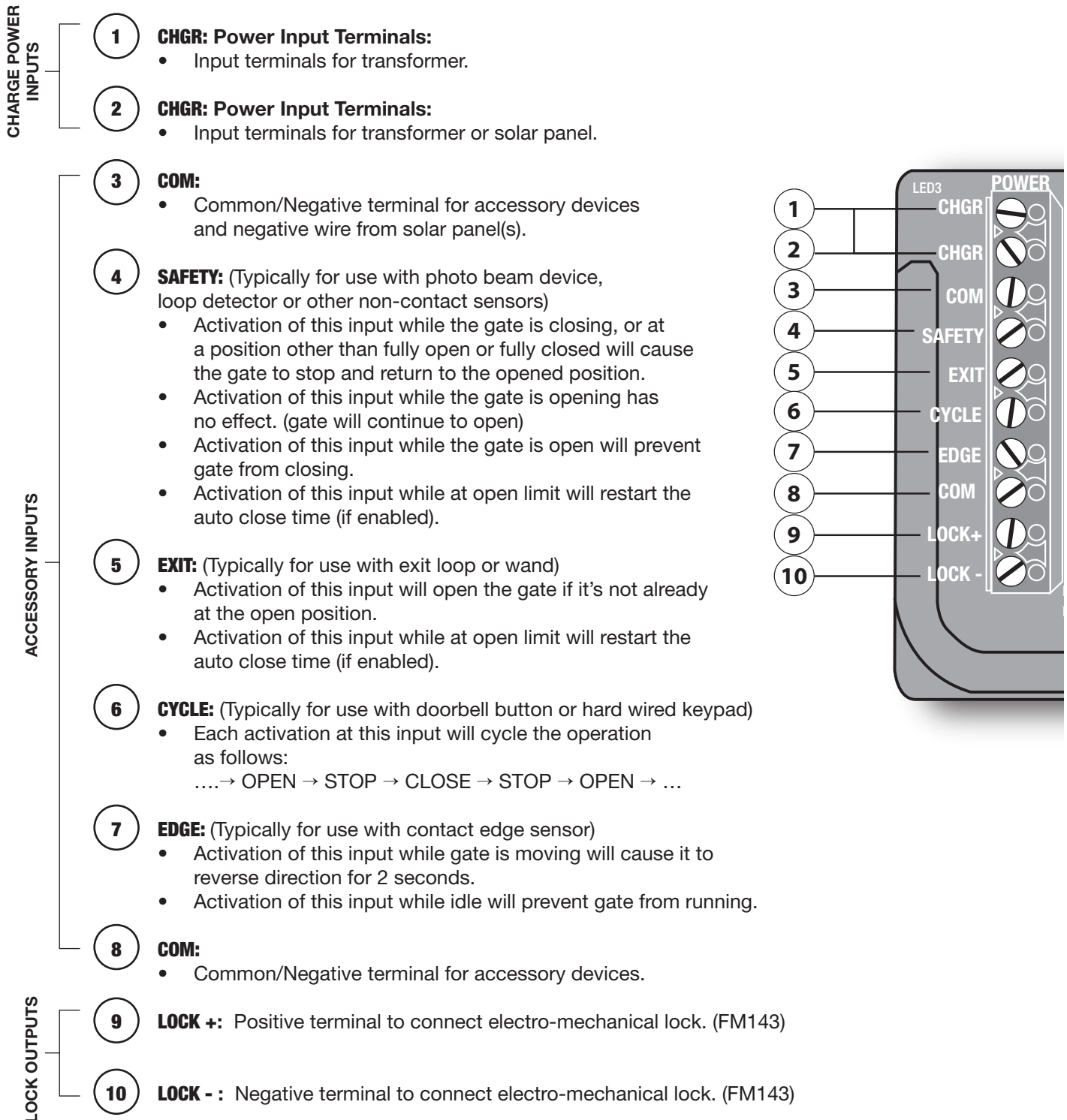

# CONNECTING ACCESSORIES

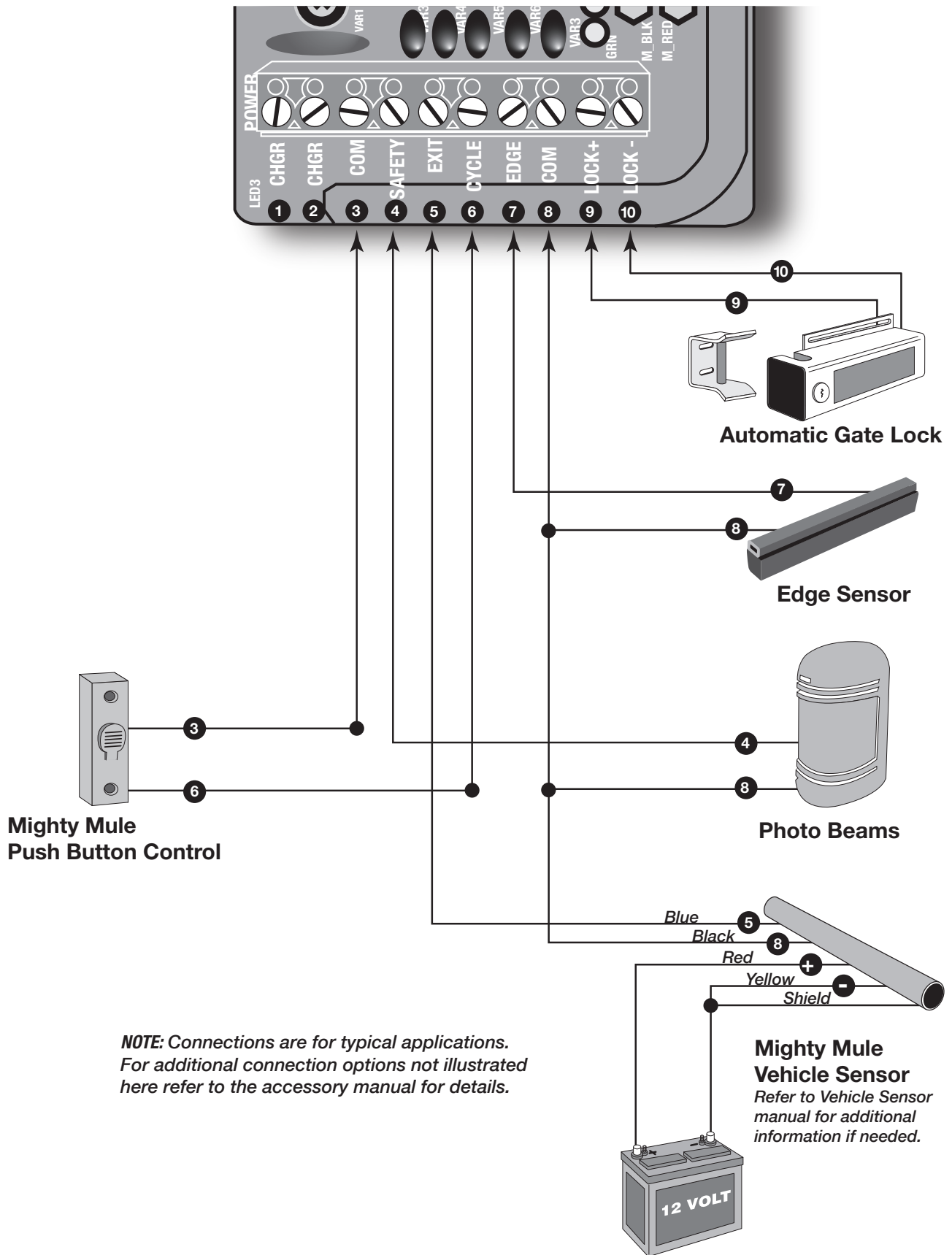

# Maintenance

- Monthly, test the obstruction and entrapment protection systems.
- Monthly, service the gate operator (make sure the power switch is OFF). Clean extended operator arm with a soft, dry clean cloth.
- On all gates weighing 250 lb. or more, routinely grease the ball bearing hinges at least 4 times a year; more frequently if the gates are near a coastal area.
- Monthly, turn off the power switch and disconnect the Mighty Mule and move the gate to make sure the gate is moving freely without sticking or binding. Lubricate the hinges or repair the gate as required before reattaching the Mighty Mule.
- Monthly, check the gate system for potential entrapments from new landscaping or construction. Eliminate or guard as required.
- Monthly, check that the warning signs are mounted on each side of the gate and clearly visible. Replace the signs if they are missing or damaged.
- Replace batteries every 2-3 years and properly recycle old batteries.



# Troubleshooting Guide

If your gate operator does not function properly after it is installed, use this guide before calling the Nortek Security & Control Service Department.

<b>AUDIBLE FEEDBACK</b>		
<b>Symptom</b>	<b>Diagnosis</b>	<b>Check</b>
1 or more short beeps upon power up	Circuit board powered up and ready	<ul style="list-style-type: none"> <li>➤ Normal operation</li> </ul>
Rapid beeping	<ul style="list-style-type: none"> <li>➤ No battery preset</li> <li>➤ Circuit board senses an obstruction</li> <li>➤ Blown fuse in battery harness cable</li> </ul>	<ul style="list-style-type: none"> <li>➤ Gate for adequate maintenance, free swinging, level and plumb</li> <li>➤ Stall Force adjustment</li> <li>➤ Disconnect obstruction detection devices</li> <li>➤ Battery connections</li> <li>➤ Check fuse</li> </ul>
1 beep every 20 seconds	Low battery	<ul style="list-style-type: none"> <li>➤ Check fuse</li> <li>➤ Battery harness connections</li> <li>➤ Battery under load or inadequate charge</li> <li>➤ AC output at 120 Vac, transformer output at 19 Vdc</li> <li>➤ Solar panel(s) output based on weather conditions</li> <li>➤ Wiring from charge source to control board, verify correct polarity</li> </ul>
2 beeps every 2 seconds	Position sensor is short circuit.	<ul style="list-style-type: none"> <li>➤ Arm power cable for damage</li> </ul>
1 beep every 2 seconds	Position sensor is open circuit.	<ul style="list-style-type: none"> <li>➤ Arm power cable for damage</li> </ul>
1 beep when attempting to run the gate	Blown fuse Battery is low or damaged Loose connection	<ul style="list-style-type: none"> <li>➤ Check fuses</li> <li>➤ Battery harness connections</li> <li>➤ Battery under load or inadequate charge</li> </ul>

Additional information can be found by contacting Nortek Security & Control.

# Troubleshooting Guide

<b>VISUAL FEEDBACK</b>		
<b>Symptom</b>	<b>Diagnosis</b>	<b>Check</b>
Power (green) ON	AC or solar power present	Normal Operation
Power (green) OFF	No AC or solar power	<p><b>Transformer:</b></p> <ul style="list-style-type: none"> <li>➤ Breaker or GFI</li> <li>➤ Power at AC outlet</li> <li>➤ Output of transformer at 19 Vdc</li> <li>➤ Voltage on wire from transformer at control board input at 19 Vdc</li> </ul> <p><b>Solar:</b></p> <ul style="list-style-type: none"> <li>➤ Wiring for solar panel(s) using correct polarity</li> <li>➤ Weather conditions, amount of sunlight</li> <li>➤ Placement of solar panel(s) is in direct sunlight</li> <li>➤ Output of solar panel(s) based on weather conditions</li> <li>➤ Voltage on wire from solar panel(s) at control board input</li> </ul>
Status (amber)	Receiving RF Signal	<ul style="list-style-type: none"> <li>➤ Check for a stuck transmitter</li> <li>➤ Receiving RF interference</li> </ul>

# Warranty Repair

If your Mighty Mule Gate Opener is not operating properly, please follow the steps below:

1. First use the procedures found in the Visual and Audible Diagnostic Indicators section ([page 29](#)).
2. Use the 24/7 Troubleshooting "Wizard" located at [www.mightymule.com](http://www.mightymule.com).
3. If you are unable to solve the problem, call the NSC Service Department at (800) 543-1236, or (850) 575-4144. Refer to the serial number (located on the back of opener arm) and date of purchase when calling for assistance.
4. If replacement of your gate opener is necessary, the Service Department will assign a **Return Authorization (RA) number** to you for all warranty repairs.
5. Securely pack the component(s) authorized for return to the factory. Write the RA number issued to you on the outside of the package in LARGE BOLD PRINT and include a copy of the proof of purchase. Ship the package(s) freight prepaid to the address supplied during the RA process:

**NOTE: Products returned to NSC without a Return Authorization (RA) number in LARGE BOLD PRINT on the outside of the package WILL NOT be accepted. Also, items returned to NSC freight collect WILL NOT be accepted.**

After the 12 month warranty expires, NSC, or one of its authorized service centers will perform necessary repairs for a nominal fee. Call NSC's Technical Service Department.



For 24 hour 7 days a week trouble shooting and support online go to our online TECH WIZARD  
[www.mightymule.com](http://www.mightymule.com)

The Mighty Mule Technical Service Department is open  
Monday – Friday 8:00 A.M. – 7:00 P.M. (Eastern Time)

**Telephone (800) 543-1236**

Web site: [www.mightymule.com](http://www.mightymule.com)



## Accessories

Accessories are Available From Your Retail Store

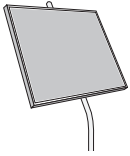

### Solar Panel (FM123)

The Solar Panel is a 10 watt solar powered battery charger for use with the Mighty Mule 271 gate operator systems. Particularly suited for remote installations, each Solar Panel comes with tubular steel support, mounting clips, wire connectors, and 10 ft. of low voltage wire (see Low Voltage Wire for additional wire). The Mighty Mule control board has clearly labeled terminal connections for easy installation of the Solar Panel. Installation in some regions of the world will require multiple solar panels for adequate charging power.



### Push Button Control (FM132)

Unlit doorbell button for remote entry or exit control. Wires directly to the control board and uses 16 gauge stranded, dual conductor low voltage wire (sold separately).

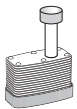

### Pin Lock (FM133)

The Pin Lock substitutes for the clevis pin at the front end of the Mighty Mule gate operators. Helps prevent theft of the operator from the gate, while allowing quick release of the operator.



### Key Chain Two Button Transmitter (FM134)

The Key Chain Transmitter is a dual button version of the Mighty Mule single button entry transmitter and has the same adjustable code settings. Used for 2 gates or 1 gate and garage door (when used with in conjunction with a garage door receiver – RB709U-NB). (Battery is included.)



### Single Button Transmitter (FM135)

The Mighty Mule entry transmitter, with adjustable code settings, is standard equipment with all Mighty Mule systems. (Battery is included.)



### MMK200 Keypad

The Mighty Mule Wireless Keypad is designed to control access to all Mighty Mule Garage Door Openers. This keypad features a LED back light that allows you to see numeric keys throughout dark or unfavorable weather conditions.



### Mounting Post (FM100) - In Ground

This black powder coated pedestal is designed to provide convenient access to your keypad, wireless intercom, or other access control device from your vehicle. With its break down design it is easy to install and works well in most standard applications. Surface Mount Flanges (F102) and Extensions (F103) for added height are available.

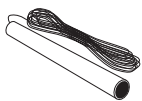

### Mighty Mule Vehicle Sensor (FM138)

The Gate Opening Sensor is designed for residential and agricultural applications and is compatible with most Mighty Mule automatic gate operator models. The Sensor is an electromagnetic sensor, which offers 'hands free' operation of the Mighty Mule Gate Operator with a 12 ft. radius of detection of vehicles in motion.



### Automatic Gate Lock Pull-to-Open (FM143)

A MUST for added security. Solenoid driven, with a steel housing. Used with Mighty Mule DC swing gate operating systems for maximum stability and security. Comes with a keyed manual release.

### MMT103

The MMT103 Code Safe digital transmitter is a wireless radio control designed for use with Mighty Mule garage door openers and can also be programmed to your Mighty Mule gate openers. One remote for two or three devices.



### Wireless Entry Intercom / Keypad (MM136)

Allows owner to screen guest at the gate before allowing access to the property. Keypad also allows owner to give up to 25 programmable entry codes to family, friends or approved delivery personnel. Codes can be permanent or temporary. Up to 500 feet reception.

Additional base stations available (MM136B).



### Low Voltage Wire (RB509)

The 16 gauge, stranded, dual conductor Low Voltage Wire is for connecting the AC powered transformer, or the Solar Panel to the control board. Also used for the connection of accessories, such as locks, keypads, push buttons and other wired control devices. This specially designed wire is UV treated, PVC coated and ready for direct burial. Available in 1000' rolls or special lengths.



### Replacement Transformer (RP1010)

Standard 19V 2A, DC power supply for maintaining the battery with the Mighty Mule gate operator.

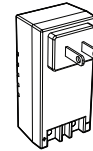

### Garage Door Receiver (RB709U-NB)

The Garage Door Receiver allows you to use the same 2 button Mighty Mule entry transmitter to operate your gate operator and your garage door operator. Compatible with most garage door operators.

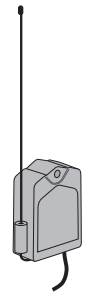

### Driveway Alarm (FM231)

This device alerts you of vehicles entering your driveway (with or without an automated gate). The indoor base station signals you with a door chime when a vehicle passes the driveway sensor.

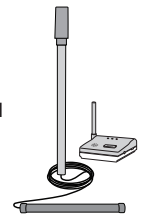

### Wireless Driveway Vehicle Sensor (FM130)

Automatically activates gate operator "Hands-Free" when a vehicle exits the property. 100 ft. range between transmitter and receiver. Easy installation.

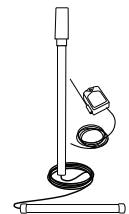

### If you have a question about any special order item, call 1-800-543-4283

The contents of all material available on this installation manual are copyrighted by Nortek Security & Control, LLC ("Nortek Security & Control"), unless otherwise indicated. All rights are reserved by Nortek Security & Control, and content may not be reproduced, downloaded, disseminated, published, or transferred in any form or by any means, except with the prior, written permission of Nortek Security & Control. Any reprinting of Nortek Security & Control publications is by permission only. Copyright infringement is a violation of federal law.

Mighty Mule®, E-Z Gate®, Nortek Security and Control®, "Dual Sense Technology" are registered trademarks of Nortek Security & Control, LLC, America's DIY Automatic Gate Openers is a trademark of Nortek Security & Control, LLC and are the exclusive property of Nortek Security & Control, LLC ("Nortek Security & Control").

All rights are reserved by Nortek Security & Control, and these marks may not be used, in any for without the prior, written permission of Nortek Security & Control.

# Gate Operator Installation Checklist

- 1. The gate has been checked to make sure it is level and moves freely in both directions.

---

- 2. Potential pinch areas have been guarded so as to be inaccessible OR have sensing edges and/or photo beam obstruction detection devices installed.

---

- 3. The installer has installed one or more contact or non-contact obstruction sensing devices, if required for this installation.

---

- 4. If pedestrian traffic is expected, a separate pedestrian gate has been installed, a minimum of seven feet from the gate system. All pedestrian traffic must use the pedestrian gate.

---

- 5. Warning signs have been installed on each side of the gate in highly visible locations. These signs must remain at all times.

---

- 6. There are no controls installed on the gate operator, or within 10 feet of the gate.

---

- 7. The Dual Sense Technology™ feature has been properly adjusted to the minimum operational setting for your application..

---

- 8. Reviewed and understand all of the operational functions, obstruction sensing devices, warning beeper and reset, etc.

---

- 9. Review and understand the proper use of the operator's manual disconnect feature. The manual disconnect must never be used while the gate is in motion. The power switch must be turned off before using the manual disconnect and disengaging the operator.

---

- 10. Reviewed all safety instructions, and keep the safety instructions and owner's information sheets for reference.

---

- 11. Review and understand the maintenance schedule for both the gate and the gate operator.



Telephone Mighty Mule Sales: (800) 543-4283  
or Mighty Mule Technical Service: (800) 543-1236  
[www.mightymule.com](http://www.mightymule.com)



The contents of all material available on this installation manual are copyrighted by Nortek Security & Control, LLC ("Nortek Security & Control"), unless otherwise indicated. All rights are reserved by Nortek Security & Control, and content may not be reproduced, downloaded, disseminated, published, or transferred in any form or by any means, except with the prior, written permission of Nortek Security & Control. Any reprinting of Nortek Security & Control publications is by permission only. Copyright infringement is a violation of federal law.

Mighty Mule®, E-Z Gate®, NSC®, "Dual Sense Technology" are registered trademarks of Nortek Security & Control, LLC. America's DIY Automatic Gate Openers is a trademark of Nortek Security & Control, LLC and are the exclusive property of Nortek Security & Control, LLC ("Nortek Security & Control").

Copyright© 2021 Nortek Security & Control, LLC. All rights are reserved by Nortek Security & Control, and these marks may not be used, in any for without the prior, written permission of Nortek Security & Control.

