

The Simple Solutions 4-in-1 multifunctional molding with universal track system uses integrated shims that can be cut off or folded under allowing this molding transition to work with vinyl floors ranging from 2mm to 8mm in height.

Refer to the installation instructions provided by the flooring manufacturer for required expansion spaces.

## STEP 1 • CHOOSE YOUR TRANSITION TYPE

Kit allows assembly of four different molding options from one single product

- A. T-Molding  
Transitions between hard surface floors of equal height
- B. Carpet Transition  
Finishes a hard surface floor where it meets carpet
- C. Hard Surface Reducer  
Transitions between hard surface floors of different heights
- D. End Molding  
Finishes a hard surface floor at sliding doors, fireplaces and other fixed edges

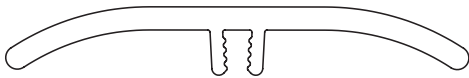

Part #1



Part #2

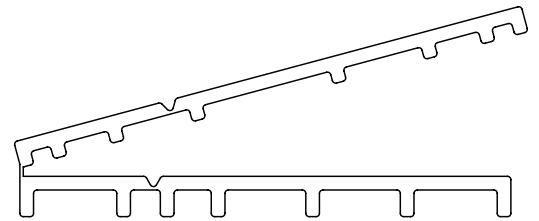

Part #3

## STEP 2 • INSTALL YOUR MOLDINGS

Each individual package includes the following:

1. Measure and trim to fit.
2. The universal shim is provided in one single piece. Follow the specific diagrams for shim usage with your specific flooring height. The shim can be separated in three places to create the 4 individual shims using a utility knife.
3. Staple, nail or glue track to subfloor.
4. Line up cover with track and use rubber mallet to tap the track and cover together.

A. T-MOLDING

Remove carpet/end molding transition support with utility knife.

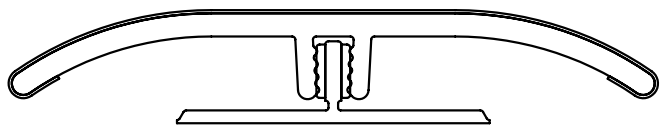
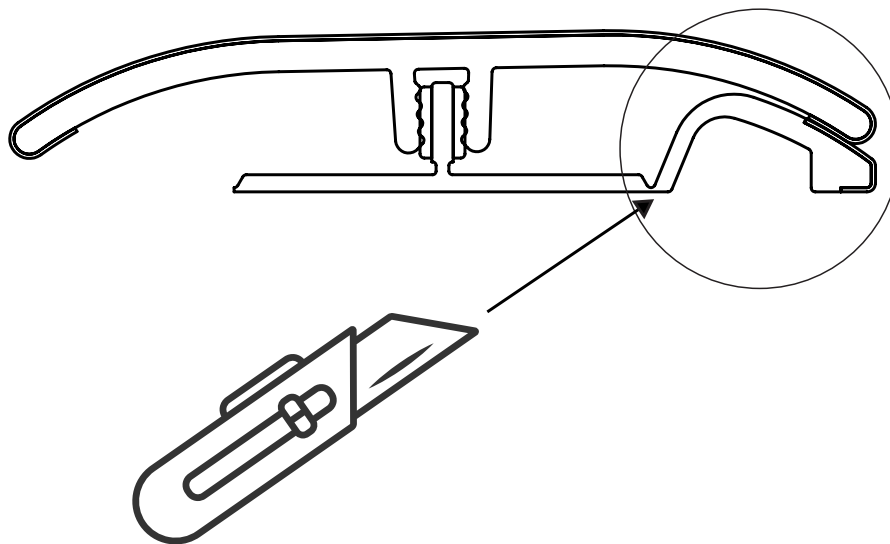

Flooring thickness = 2mm - 3mm

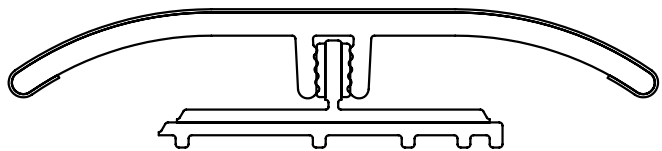

Flooring thickness = 4mm - 5mm

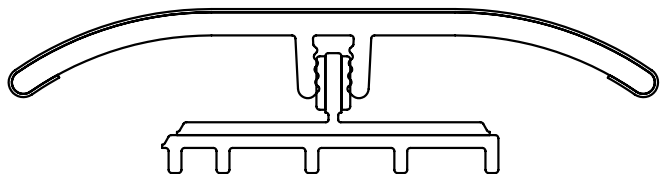

Flooring thickness = 6mm

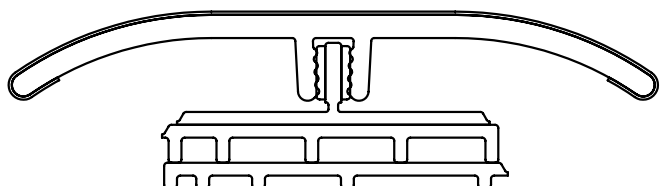

Flooring thickness = 7mm - 8mm

B. CARPET TRANSITION

Remove carpet/end molding transition support with utility knife

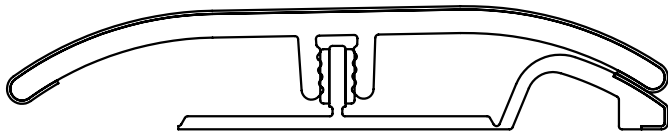

Flooring thickness = 2-3mm

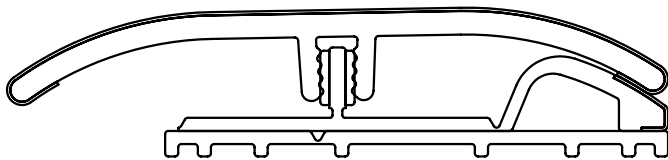

Flooring thickness = 4mm

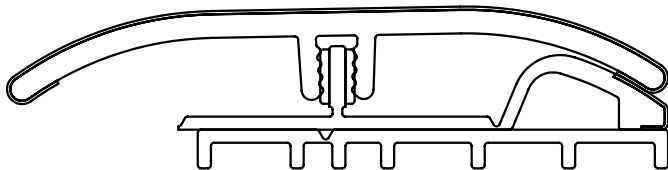

Flooring thickness = 5mm

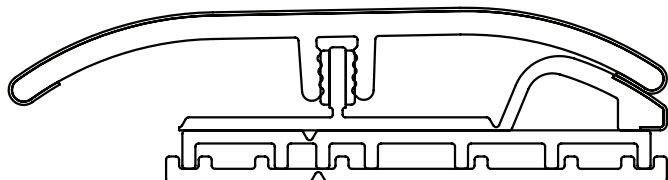

Flooring thickness = 6mm

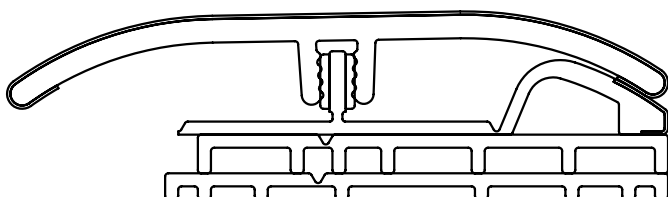

Flooring thickness = 7mm - 8mm

C. HARD SURFACE REDUCER

Remove carpet/end molding transition support with utility knife

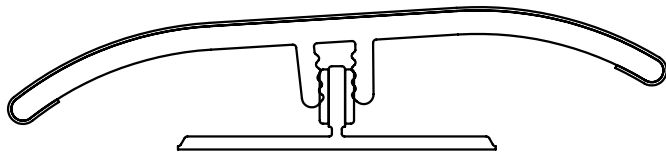
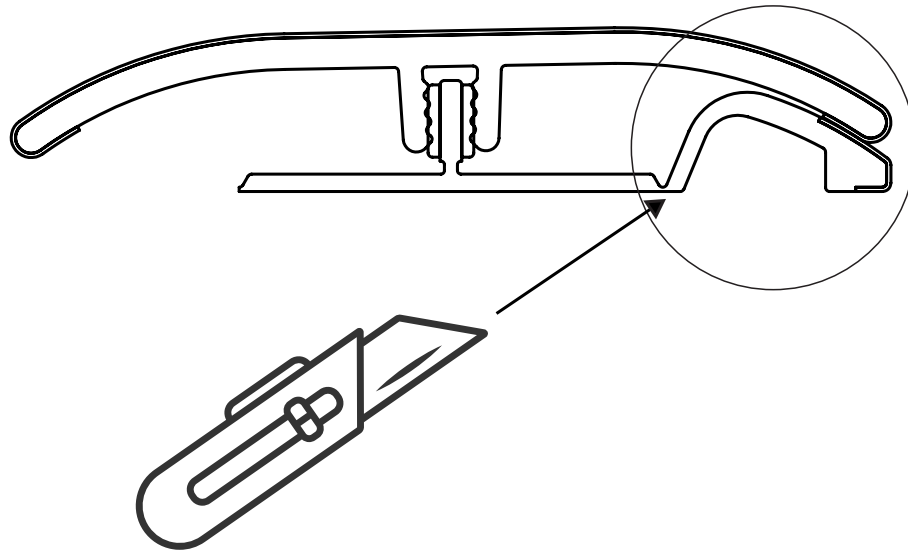

Flooring thickness = 3mm - 5mm

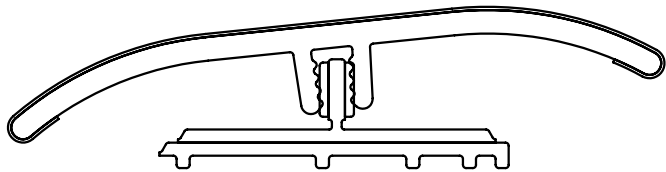

Flooring thickness = 6mm - 7mm

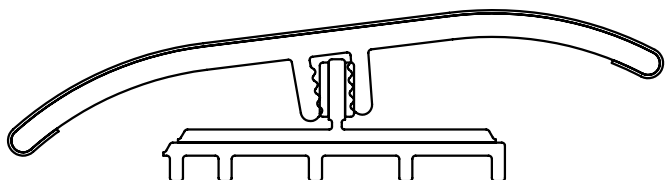

Flooring thickness = 8mm

D. END MOLDING

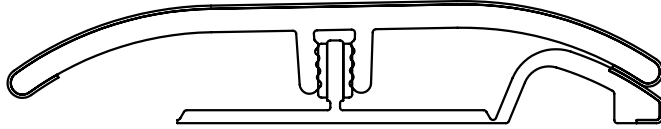

Flooring thickness = 2-3mm

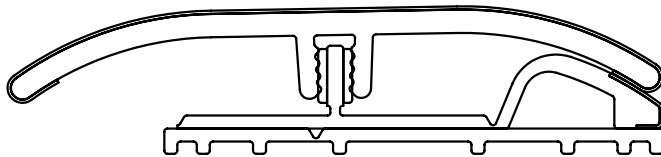

Flooring thickness = 4mm

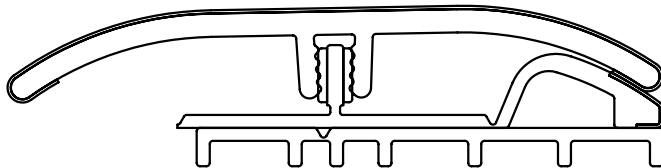

Flooring thickness = 5mm

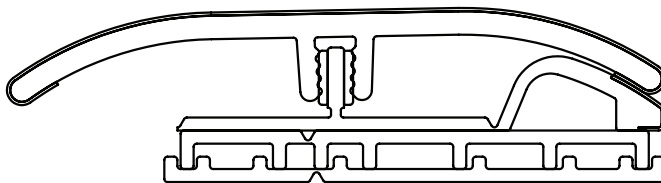

Flooring thickness = 6mm

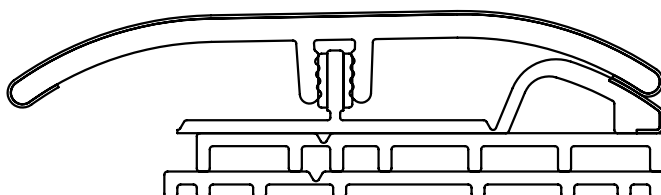

Flooring thickness = 7mm - 8mm