



**LG**

Life's Good

ENGLISH

# OWNER'S MANUAL DISHWASHER

Please read this owner's manual thoroughly before operating and keep it handy for reference at all times.

LDS5540ST/WW/BB



P/No. : MFL66281421

[www.lg.com](http://www.lg.com)

# TABLE OF CONTENTS

## **3 IMPORTANT SAFETY INFORMATION**

---

- 3 Basic Safety Precautions
- 4 Electrical Safety
- 4 Before Using the Dishwasher

## **5 PARTS AND FEATURES**

---

- 5 Features
- 6 Parts
- 6 Specifications
- 7 Control Panel
- 9 Cycle Option Chart
- 9 Cycle Selection Chart

## **10 OPERATING INSTRUCTIONS**

---

- 10 Quick Start
- 11 Loading the Lower Rack
- 12 Folding Down the Lower Tines
- 13 Loading the Silverware Basket
- 13 Height adjustable upper rack
- 14 Loading the Upper Rack
- 14 Folding Down the Upper Tines
- 15 Adding Detergent to the Dispenser
- 16 Adding Rinse Aid to the Dispenser

## **17 CARE AND CLEANING**

---

- 17 Keeping the dishwasher
- 17 Cleaning the Metallic Parts
- 17 Cleaning the Upper Spray Arm
- 18 Cleaning the Top Spray Arm
- 18 Seasonal Maintenance and Storage

## **19 FAQs**

---

## **21 TROUBLESHOOTING**

---

- 21 Before Calling for Service
- 23 Smart Diagnosis System

## **24 WARRANTY**

---

- 24 Product Registration Information

# IMPORTANT SAFETY INSTRUCTIONS

## READ ALL INSTRUCTIONS BEFORE USE

Your safety and the safety of others is very important. This owner's manual contains many important safety messages; as well as on your appliance. Always read and follow all safety messages.



This is the safety alert symbol. This symbol alerts you to potential hazards that can result in property damage or serious bodily harm, even death.

The safety alert symbol will be followed by either the word "WARNING" or "CAUTION" then an important safety message. These words mean:

**⚠ WARNING** Indicates the possibility of serious bodily harm or death.

**⚠ CAUTION** Indicates the possibility of injury or damage to property.

This manual contains very important information regarding the installation, use, and maintenance of your dishwasher. The manufacturer cannot be responsible for injuries or damage caused by failure to follow these safety and caution instructions.

## BASIC SAFETY PRECAUTIONS

**⚠ WARNING** To reduce the risk of fire, electric shock, or injury to persons when using this appliance, follow basic precautions, including the following:

- Read all instructions carefully before using the dishwasher.
- Use the dishwasher only for its intended function.
- Only use detergents or rinse agents recommended for use in a dishwasher. Keep all dishwasher detergents and additives out of the reach of children.
- This appliance is not intended for use by young children.
- When loading items to be washed:
  - 1) Load sharp items so that they are not likely to damage the door seal.
  - 2) Load sharp knives with the handles up to reduce the risk of injury when reaching into the dishwasher.
- Do not wash plastic items in the dishwasher unless they are labeled "dishwasher safe" or the equivalent. For plastic items that are not so labeled, check the manufacturer's recommendations.
- Do not operate the dishwasher unless all enclosure panels are properly in place.
- Do not tamper with the controls.
- Do not abuse, sit on, or stand on the door or dish racks of the dishwasher.
- To reduce the risk of injury, do not allow children to play in or around the dishwasher.
- Under certain conditions, hydrogen gas may be produced in a hot water system that has not been used for two weeks or more. HYDROGEN GAS IS EXPLOSIVE. If the hot water system has not been used for such a period of time, turn on all hot water faucets and let the water flow for several minutes. This will release any accumulated hydrogen gas. Since hydrogen gas is flammable, do not smoke or use an open flame during this time.
- Remove the door to the wash compartment when disposing of an old dishwasher.
- The installer must ensure that the dishwasher is completely enclosed at the time of installation.

**WARNING:** This product contains chemicals known to the State of California to cause cancer and birth defects or other reproductive harm. **Wash hands after handling.**

## BASIC SAFETY PRECAUTIONS

**⚠ WARNING** To reduce the risk of fire, electric shock, or injury to persons when using this appliance, follow basic precautions, including the following:

### For a permanently connected dishwasher:

This appliance must be connected to a grounded metal, permanent wiring system, or an equipment grounding conductor must be run with the circuit conductors and connected to the equipment grounding terminal or lead on the appliance. Consult with a qualified electrician.

### Tip Hazard

Do not put excessive downward force on the open dishwasher door prior to installation, as this could cause damage to the unit or cause it to tip over. Do not use the dishwasher before installation has been completed in accordance with the Installation Instructions.

## ELECTRICAL SAFETY

### ⚠ WARNING

#### Electrical Shock Hazard

Failure to follow these instructions can result in death, fire, or electrical shock.

- The dishwasher **MUST** be grounded. Connect the ground wire to the green ground connector in the terminal box.
- Do not use an extension cord with this appliance.
- The dishwasher is designed to be used with standard household current (120 Volts AC, 60Hz.). Before connecting the dishwasher, ensure that the outlet or cable is properly grounded and polarized by circuit breakers or fuses. Failure to provide adequate grounding of this appliance may cause electrical shock or malfunction of the appliance. Consult with a qualified electrician.
- Do not install or store the dishwasher where it will be exposed to weather conditions. Failure to observe this precaution may result in electrical shock, fire, malfunction, and/or deformation of the dishwasher.
- Do not damage or place heavy items on the power cord of the appliance. Do not use the dishwasher if it has a damaged power cord. Power cord damage may cause fire and electrical shock. Consult with a qualified electrician.
- Do not grasp the power cord or touch the dishwasher controls with wet hands. Do not use the dishwasher if it has a damaged power cord or plug, and do not plug the dishwasher into a damaged outlet. Failure to observe these instructions may result in electrical shock.
- Disassembly or repair must be performed by experienced service persons. Improper disassembly or repair could lead to product failure or electrical shock.

## BEFORE USING THE DISHWASHER

Before using the dishwasher, please read the Important Safety Instructions.

Water supply temperature should be a minimum of 120°F (49°C) for better washing and reasonable cycle time.

For this reason, use the hot water supply only. It is also important that the dishwasher is loaded according to instructions for effective cleaning. When loading the dishwasher, make sure that insoluble items such as bones, toothpicks, and pieces of paper have been removed.

When loading the dishwasher, observe the following general guidelines:

1. Place items with deep dish bottoms at an angle to help water run off and speed the drying process.
2. Remove solid, burned-on scraps from dishes prior to loading in the dishwasher.
3. Only load items that are dishwasher-safe.

### ⓘ NOTE

Do not load utensils that are not heat-resistant, have decorative metal trim, etc.

## SAVE THESE INSTRUCTIONS

# PARTS AND FEATURES

## FEATURES

### LARGE CAPACITY

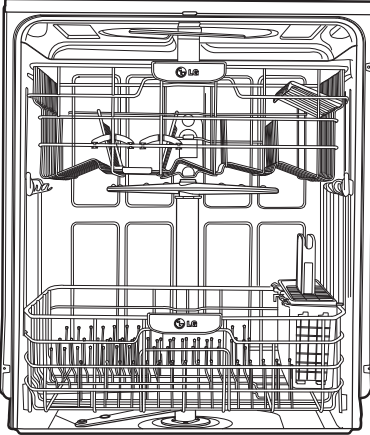

LG dishwashers allow you to load very large items in both the upper and lower racks. The tall tub provides extra overall capacity and the clearance to accommodate large dishes. Extra large items (max. 14 in.) may be loaded in the lower rack by raising the upper rack.

### SLIM DIRECT MOTOR™

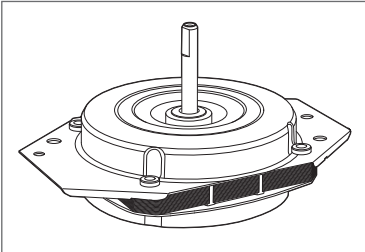

The new Slim Direct Motor™ is inverter-controlled. Wash power is controlled based on cycle selection. It also offers high energy efficiency to minimize energy use.

### HYBRID DRYING SYSTEM

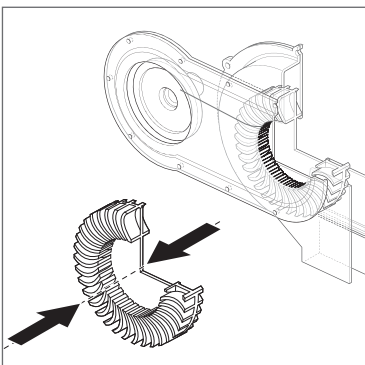

This system effectively dries dishes without the use of a heating element that would increase energy consumption.

### VARIO SPRAY SYSTEM

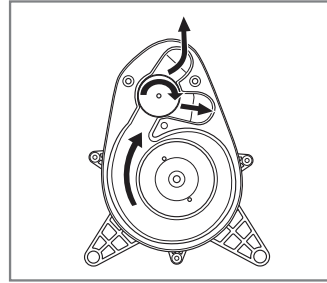

The water spray alternates between the upper and lower racks, so all of the power from the motor is directed to one rack at a time. This concentrates all of the cleaning power of the motor on each rack in turn.

### SOFT FOOD GRINDER AND SELF-CLEANING FILTER

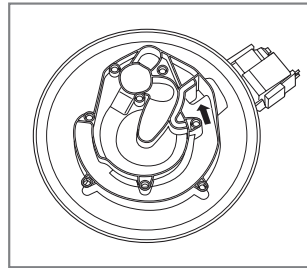

For best wash results, your LG dishwasher has a built-in soft food grinder and a selfcleaning filter. The grinder grinds up soft food and residue into small particles that can be caught in the filter and washed down the drain. The self-cleaning filter system continuously cleans the wash water as

it circulates to separate any residue from the wash water. All dirt and residue easily washes down the drain.

## PARTS

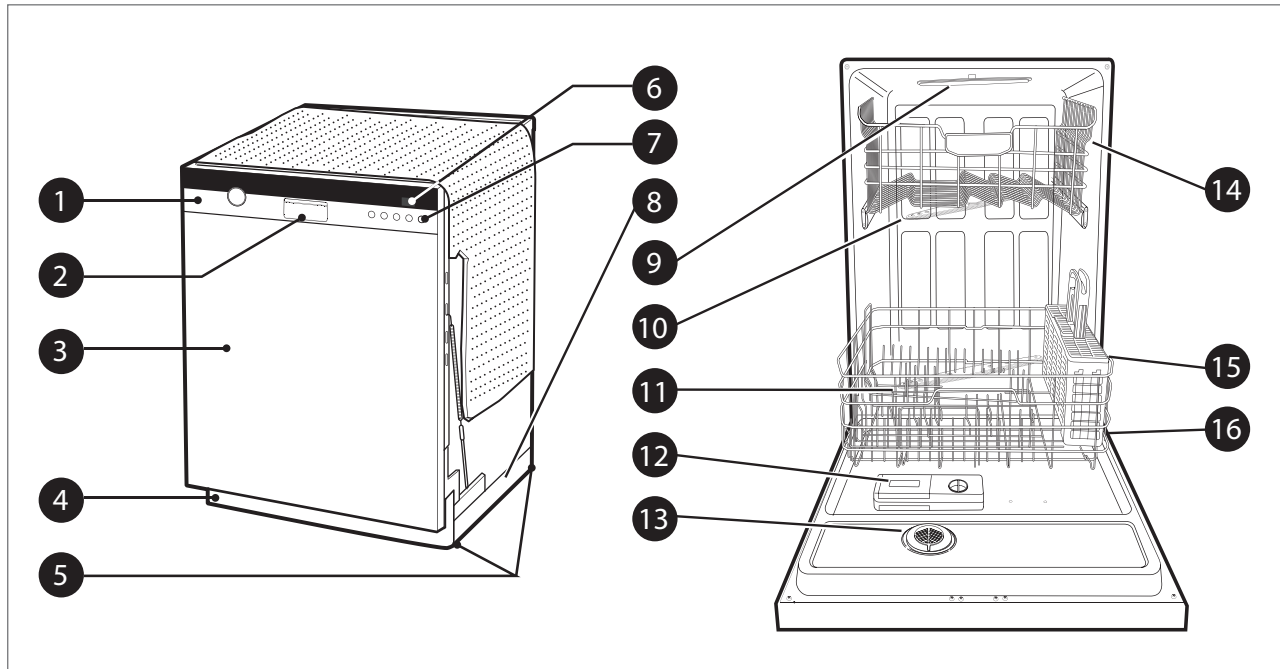

- |                   |                                       |
|-------------------|---------------------------------------|
| 1. CONTROL PANEL  | 10. UPPER SPRAY ARM                   |
| 2. DOOR HANDLE    | 11. LOWER SPRAY ARM                   |
| 3. FRONT COVER    | 12. DETERGENT AND RINSE AID DISPENSER |
| 4. LOWER COVER    | 13. DRYING VENT COVER                 |
| 5. LEVELING FEET  | 14. UPPER RACK                        |
| 6. DISPLAY WINDOW | 15. SILVERWARE BASKET                 |
| 7. POWER BUTTON   | 16. LOWER RACK                        |
| 8. BASE           |                                       |
| 9. TOP SPRAY ARM  |                                       |

## SPECIFICATIONS

Model: LDS5540ST/WW/BB	
Power Supply	120V, 60 Hz AC only, minimum 15A circuit breaker
Water Pressure	20–120 psi (140–830 kPa)
Size (WxDxH)	23 3/4" x 24 5/8" x 33 1/2" (603 mm x 625 mm x 851 mm)
Inlet Water Temperature	120°F (49°C) minimum
Product Weight	90.8 lbs. (41.2 kg)

The appearance and specifications are subject to change without notice.

## CONTROL PANEL

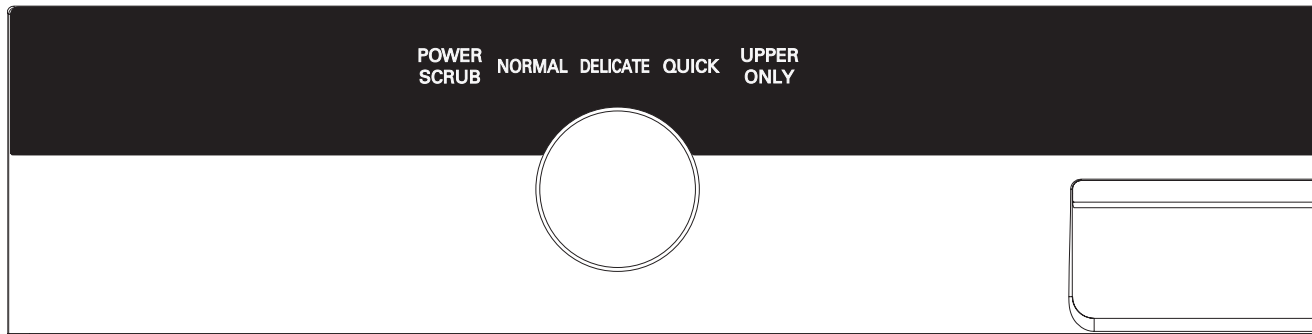

### Cycles

Select your desired cycle.

#### POWER SCRUB

This cycle is for heavily and hard soiled dishes. Power Scrub can also help reduce hard water spotting on dishes.

#### NORMAL

This cycle is for normally soiled, everyday loads.

#### DELICATE

The cycle is intended for effectively cleaning delicate items such as fine china and stemware.

#### QUICK

This is a shortened cycle that is intended for washing and drying recently used dishes or lightly soiled loads.

#### UPPER ONLY

This cycle is only for washing items placed on the upper rack.

#### CHIME ON/OFF

To enable or disable the chime, first, turn on the dishwasher. Press and hold the Extra Dry and Delay Start buttons simultaneously for approximately three seconds.

#### TO CANCEL A CYCLE

To cancel a cycle, open the door and then press and hold the Extra Dry and Extra Rinse buttons simultaneously for approximately three seconds. The drain pump will activate and the cycle will cancel. The display will show "dr" and the dishwasher will drain the water. After the dishwasher is drained, the power will turn off.

If power is turned on and no cycle has been selected, the dishwasher will power off within four minutes.

## CONTROL PANEL



### Cycle Options

Press the desired cycle and then select the options for that cycle.

#### SANITARY

This high-temperature rinse sanitizes dishes and glassware in accordance with NSF/ANSI Standard 184 for residential dishwashers. Certified dishwashers are not intended for licensed food establishments.

#### EXTRA DRY

Select the EXTRA DRY option for better drying performance. This option adds 60 minutes of extra drying time to the cycle.

#### EXTRA RINSE

The Extra Rinse symbol indicates that an extra rinse has been added to the cycle.

#### DELAY START

The Delay Start feature allows you to delay the start of a selected cycle. Each time the Delay Start button is pressed, the delay time will increase an hour. The delay start time can be set from 1 to 19 hours, in one-hour increments.

#### CHILD LOCK

The Child Lock feature helps prevent your settings from being changed during a cycle. Selecting this feature locks all of the buttons, except for the Power button, on the control panel. This feature does not lock the door.

#### To activate the Child Lock:

1. Press the Power button.
2. Select the cycle (and desired options).
3. Press and hold the Extra Rinse and Delay Start buttons for three seconds. The Child Lock indicator will illuminate in the display once the Child Lock is activated.

### DIGITAL DISPLAY

The Digital Display on the control panel shows the ESTIMATED cycle time. When the dishwasher is powered up, the display will be blank. When the cycle and options are selected, the display will show the total estimated time to complete those selections. During operation, the display shows the remaining estimated operating time.

### NOTE

- The estimated time shown in the display does not include delay times for heating water, etc.
- If Delay Wash is selected, the display shows the delay time in hours.
- Time may vary depending on the soil level of your load.
- The RINSE AID symbol  indicates that the rinse aid needs to be refilled.

### POWER

- Press the Power button to turn on the control panel. If no cycle is selected within four minutes, the dishwasher will power off.
- After the cycle is complete, the power automatically turns off for safety and to reduce energy consumption."
- If there is a power surge, power outage, or disruption of any kind, the PF indicator will display and power will be automatically turned off for safety. The cycle will need to be restarted.

### SMART DIAGNOSIS

Should you experience any problems with your dishwasher, it has the capability of transmitting data to your Smart Phone using the LG Smart Laundry & DW Application or via you telephone to the LG call center.

### NOTE

Smart Diagnosis is a troubleshooting feature designed to assist, not replace, the traditional method of troubleshooting through service calls. The effectiveness of this feature depends upon various factors, including, but not limited to, the reception of the cellular phone being used for transmission, any external noise that may be present during the transmission, and the acoustics of the room where the machine is located. Accordingly, LG does not guarantee that Smart Diagnosis would accurately troubleshoot any given issue.



## CYCLE OPTION CHART

The cycle guide below shows the available options for each cycle.

Cycle	Sanitary	Extra Dry	Extra Rinse	Sanitary Extra Dry	Sanitary Extra Rinse	Extra Dry Extra Rinse	Sanitary Extra Dry Extra Rinse	Delay Start
Power Scrub	●	●	●	●	●	●	●	●
Normal	●	●	●	●	●	●	●	●
Delicate	●	●	●	●	●	●	●	●
Quick		●						●
Upper Only								●

## CYCLE SELECTION CHART

The cycle guide below shows the default settings for each cycle.

Cycle	Wash			Rinse			Dry	*Water Usage	**Cycle Time
	Pre 1	Pre 2	Main Wash	Rinse 1	Rinse 2	Heated Rinse			
Power Scrub	●	●	145°F 63°C ●	●	●	154°F 68°C ●	●	7.7 gal. 29 L	166 min.
Normal	●	●	140°F 60°C ●	●		149°F 65°C ●	●	6.3 gal. 24 L	141 min.
Delicate	●	●	122°F 50°C ●	●		154°F 68°C ●	●	6.1 gal. 23 L	130 min.
Quick	●		115°F 46°C ●	●		140°F 60°C ●	●	5 gal. 19 L	84 min.
Upper Only	●	●	140°F 60°C ●	●		149°F 65°C ●	●	6.1 gal. 23 L	107 min.

\* Actual water consumption will vary depending on soil level and water hardness.

\*\* Actual cycle times may vary depending on soil level, water temperature and hardness

# OPERATING INSTRUCTIONS

## QUICK START

### 1. LOAD THE DISHES

Scrape the dishes free of excess food, bones, and any other hard, non-soluble residue. Pull each rack out and load the dishes as described in this manual.

### 2. MEASURE THE DETERGENT

Using the guidelines in this manual, fill the detergent cup with the recommended amount of detergent and close the lid. If a prewash is desired, the recess on top of the lid should also be filled with detergent.

### 3. TURN ON THE DISHWASHER

To turn on the display panel, press the Power button.

### 4. CHECK THE RINSE AID

The Rinse Aid indicator light will illuminate if the level of rinse aid in the dishwasher is low. Add rinse aid if the level is low to maintain the effectiveness of the dry cycle.

### 5. SELECT THE CYCLE AND OPTIONS

Select the cycle and options that best fit the load by referring to the Cycle Selection Chart. The display will show the estimated time for the cycle and options selected.

### 6. CLOSE THE DOOR

The dishwasher will start automatically, after a slight delay, when the door is closed and latched. During the cycle, the display will indicate the estimated time remaining for the cycle and options selected. If the door is opened during the cycle, the dishwasher will stop. When the door is closed, the cycle will resume from the point where it was stopped.

### 7. END OF CYCLE

When the cycle is complete, a chime will sound and the display will show "END." After a short time, the display and controls will shut off for safety and energy conservation.

## CAUTION

Empty the lower rack first and then the upper rack. This will avoid water from dripping from the upper rack onto dishes in the lower rack.

## WARNING

In general, it is not advisable to open the door while the dishwasher is in operation. If the door is opened, a safety device stops the dishwasher. Care should be taken when opening the door immediately following the cycle, as steam may escape.

## AUTO-OFF

The dishwasher will automatically turn off if a cycle is not selected or if the door is not closed within four minutes.

## LOADING THE LOWER RACK

### ⚠ CAUTION

#### NON-DISHWASHER SAFE ITEMS

The combination of high water temperature and dishwasher detergents may damage certain items. LG does not recommend washing the following items in the dishwasher:

- Hand painted silver or gold leaf dishes
- Wood or bone handled utensils
- Iron or other rust prone utensils
- Plastic items that are not dishwasher safe

When in doubt, check the manufacturers' recommendations.

The extra tall tub allows loading of dishes, pans, or other utensils up to 14 inches high.

The lower rack is recommended for dinner plates, soup bowls, dishes, pots, pans, lids, and grill trays. Plates should be positioned vertically and facing the center of the rack. Pots, pans, and large bowls must be turned so that the inside faces downward. The silverware basket may be used in either the lower or upper rack.

### RACK LOADING TIPS

#### LOADING 10 PLACE SETTINGS



- Load plates, soup bowls etc. between the tines.
- Load cookie sheets, cake pans and other large items on the sides or back of the rack. Loading these items in the front of the dishwasher can prevent the water spray from reaching the detergent dispenser.
- Make sure that pot handles and other large items do not stop the rotation of the spray arms.

The lower rack should not be used for small items such as cups, wine glasses, or small plates. These items should be loaded in the upper rack.

#### LOADING 12 PLACE SETTINGS

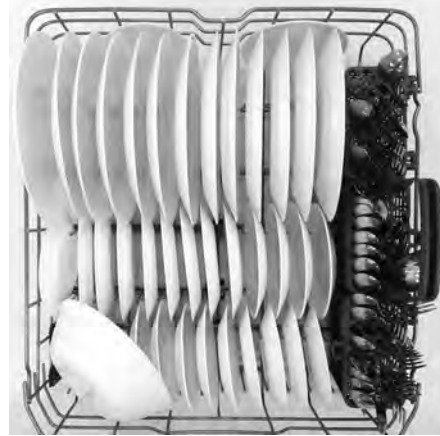

### ! NOTE

Make sure that large items do not interfere with the rotation of the spray arms, and do not prevent the detergent dispenser from opening.

## FOLDING DOWN THE LOWER TINES

The tines are adjustable to fit dishes of various sizes.

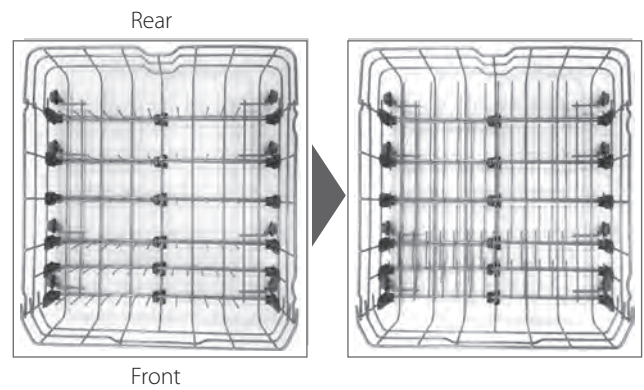
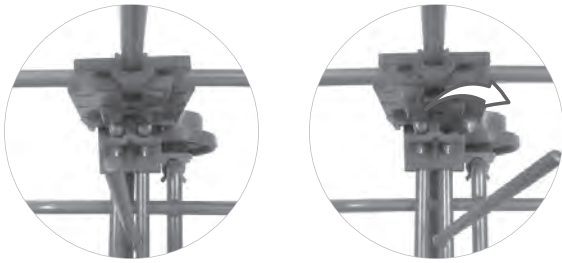

## LOADING DISHES & POTS

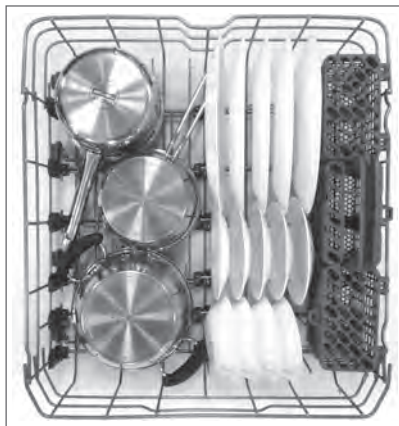

## LOADING POTS & BOWLS



## LOADING THE SILVERWARE BASKET

The silverware basket has separators to avoid scratching and tarnishing of delicate silverware. The basket can be separated into three separate baskets that can be used individually in both the upper and lower racks. Unlock the tabs above the left and right side to separate.



### ⚠ WARNING

Be careful when loading and unloading sharp items. Load sharp knives with the handles up to reduce the risk of personal injury.

#### SILVERWARE LOADING TIPS:

- For best cleaning results, use the top separators in the basket when loading silverware. The separators will prevent nesting of silverware.
- Load sharp items, such as knives, pointing down.
- When unloading the dishwasher, it is best to start with the silverware basket. Doing so will prevent water droplets from falling on your silverware from the upper rack.

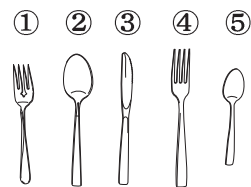
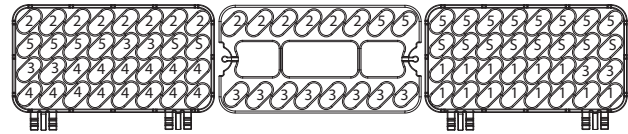

## HEIGHT ADJUSTABLE UPPER RACK

The upper rack adjusts up and down. Adjust the upper rack up to allow tall and oversized items of up to 14 inches high in the lower rack. Adjust the upper rack down to allow placement of large dishes of up to 12 inches high in the upper rack. The upper rack comes in the upper position.

### ! NOTE

After adjusting, make sure that dishes in the upper and lower racks do not interfere with the rotation of the spray arm. Do not adjust the rack while it is loaded with dishes.

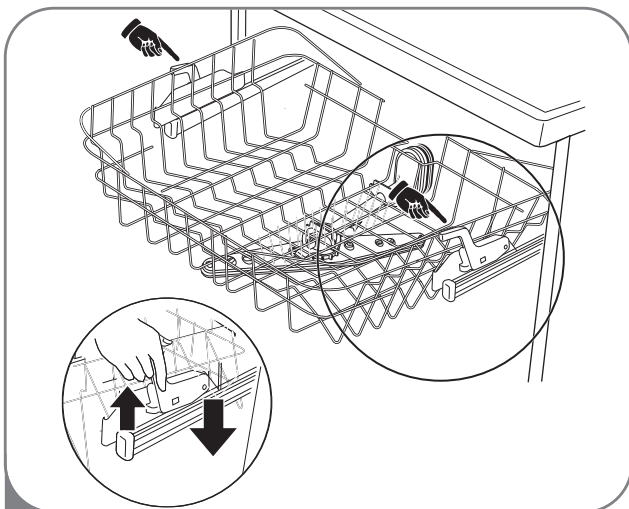

- 1 To lower the rack:  
Hold the rack at the center of each side to support its weight. Then, lift the lever on each side to release the rack and lower it to the lower position.

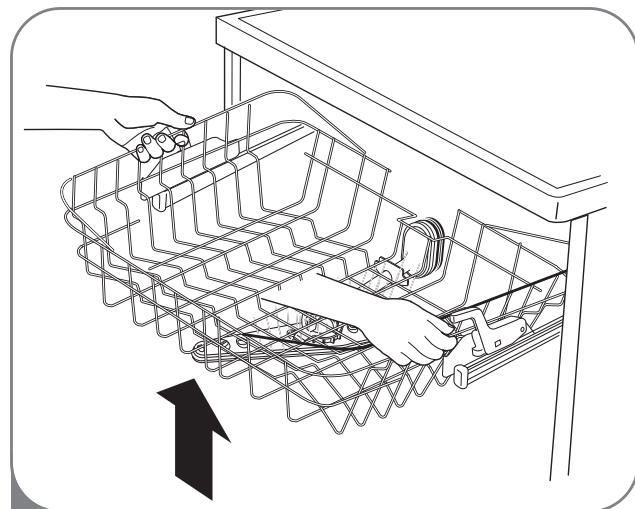

- 2 To raise the rack:  
Simply lift the rack at the center of each side (see illustration) until the rack locks into place in the upper position. It is not necessary to lift the lock levers to raise the rack.

## LOADING THE UPPER RACK

Use the upper rack for small or delicate items such as small plates, cups, saucers, glasses, and dishwasher-safe plastic items. Cups, glasses, and bowls must be positioned upside down. Extra cups or cooking utensils can be laid on the fold down cup racks, which may also provide support for long stemmed glasses. Make sure items do not interfere with the rotation of the spray arms above and below the upper rack.

### LOADING 10 PLACE SETTINGS



### LOADING 12 PLACE SETTINGS



### UPPER RACK LOADING TIPS:

- Place cups and glasses in the rows between the rack tines. Placing them over the rack tines can lead to breakage and water spots.
- To avoid chipping, do not let stem ware touch other items.
- Place items so that the open end faces down for cleaning and drying.
- Do not stack items on top of each other.

## FOLDING DOWN THE UPPER TINES

Pull up the tine



Rotate the tine

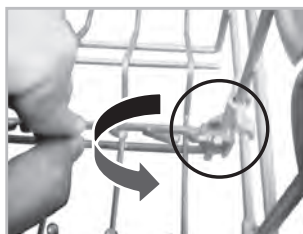

The tines can be adjusted up or down. The right side tines have handles for wider or small dishes.

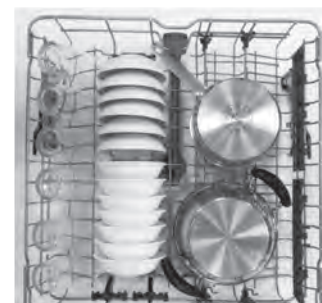

## ADDING DETERGENT TO THE DISPENSER

- Only use detergent intended for automatic dishwashers.
- Detergent must be put into the detergent compartment before starting any cycle.
- Use less detergent if the dishes are only lightly soiled. Using excess detergent can leave a film on dishes and in the dishwasher resulting in poor wash performance.
- The amount of detergent needed depends on the cycle, load size, and soil level of dishes.

### ! NOTE

Remove the label on the dispenser prior to running the dishwasher.

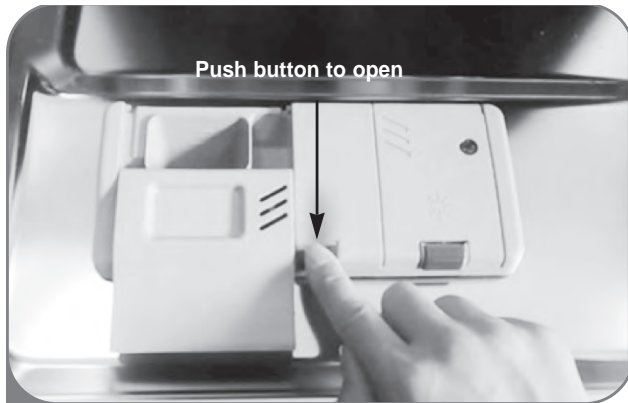

- 1 If the lid is closed, press the lever on the bottom side of the lid to open the dispenser.

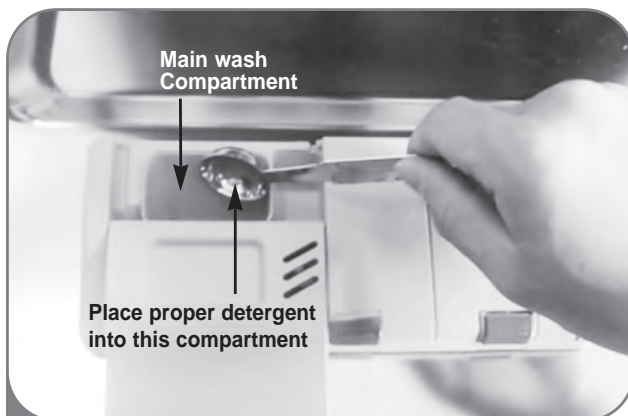

- 2 Add dish washing detergent to the main wash compartment until the level is between the lines marked 20 and 30. Fill to the 30 line for hard water or heavily soiled loads. Fill to the 20 line for soft water or lightly soiled loads.

Close the lid firmly until it clicks.



- 3 If a prewash is desired, fill the recessed prewash compartment area in the lid with detergent.

### ! NOTE

Too much detergent can leave a film on dishes and in the dishwasher, resulting in poor wash performance. Do not use detergent tablets for shorter wash cycles. The tablet may not dissolve completely, causing detergent residue on dishes and inefficient cleaning.

### ! CAUTION

#### DETERGENT INFORMATION

Use only detergent intended for automatic dishwashers. Incorrect detergent may cause the dishwasher to fill with suds during operation. Excess sudsing may reduce wash performance and may cause the dishwasher to leak. **DO NOT** use hand dish washing detergent in this dishwasher.

## ADDING RINSE AID TO THE DISPENSER

 The Low Rinse Aid indicator will appear in the display when more rinse aid is needed.

The use of rinse aid is recommended to prevent water droplet spots on dishes and to enhance the drying performance.

### ! NOTE

Only use liquid rinse aid in the dishwasher.



1 Push button to open lid.

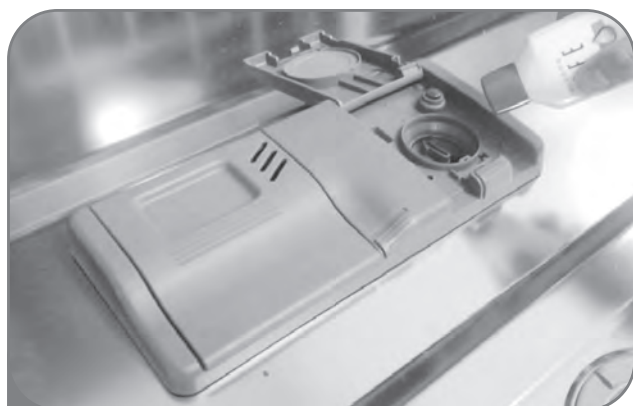

2 Add a liquid rinse aid to the maximum fill level. When filling the rinse aid dispenser, aim the rinse aid at the arrow. Make sure that the rinse aid is settled in the dispenser while filling.



3 Close the lid to lock the dispenser. Rinse aid will be dispensed automatically during the final rinse cycle.

### RINSE AID DISPENSER ADJUSTMENT

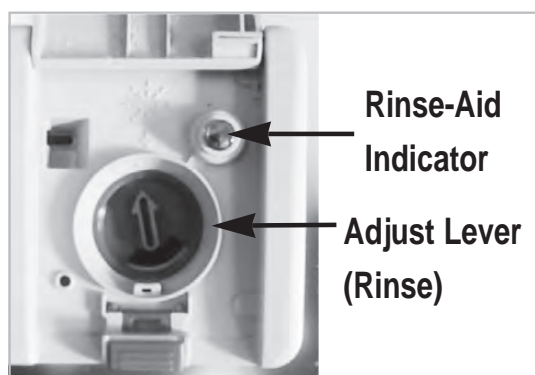

The rinse aid dispenser is set to level 3, which should provide the best performance under most conditions. Adjust the setting higher if you have hard water and notice calcium buildup on your dishes.

If you notice film on your dishes, use a lower setting. Setting the rinse aid control too low will contribute to spotting and streaking of dishes and poor drying performance. Setting the control too high can cause foaming, which will cause poor wash performance.

To adjust the rinse aid dispenser setting, remove the cap and adjust the rinse aid lever to the desired setting. Point the arrow to the left for a lower setting, right for a higher setting.

### REFILLING THE RINSE AID

The regularity of the dispenser needing to be refilled depends on how often dishes are washed and the rinse aid setting used. If the rinse aid level is low, the Rinse Aid light on the control panel will illuminate.

### RINSE AID FILLING TIPS:

-  The Low Rinse Aid indicator will appear in the display when more rinse aid is needed.
- Do not overfill the rinse aid dispenser.
- Clean up any spilled rinse aid to prevent sudsing.



## CARE & CLEANING

For best results, it is important to periodically check and care for the spray arms.

### ⚠ WARNING

To prevent injury during care and maintenance/cleaning, wear gloves and/or protective clothing.

### KEEPING THE DISHWASHER

If you will not be using the dishwasher for a long period time, run the Quick cycle without detergent. When the cycle is finished, clean the dishwasher according to the CARE & CLEANING instructions to remove the food debris at the bottom of the dishwasher and close the door.

### CLEANING THE METALLIC PARTS

Some exterior and interior parts can be cleaned with a damp cloth or sponge. A cloudy film may form on the surface of the stainless steel tub, especially with hard water.

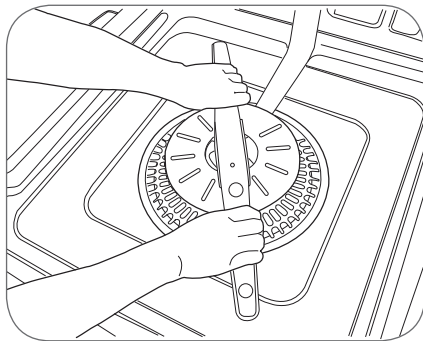

- Make sure that the water jet holes are not blocked by food particles.
- When cleaning is necessary, remove the lower spray arm by pulling up.
- After cleaning the lower spray arm, replace it by pushing down until it clips into place. Be sure that the spray arm is able to turn freely.

### CLEANING THE UPPER SPRAY ARM

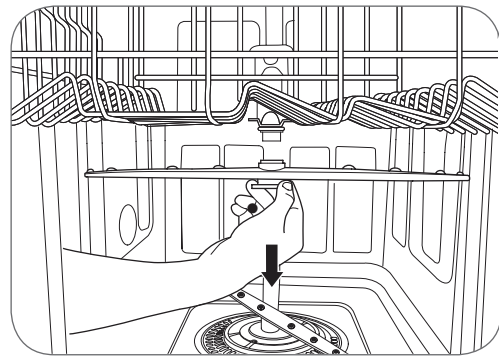

- Pull the upper rack forward. Make sure that the water jet holes are not blocked by food particles.
- When cleaning is necessary, remove the upper spray arm by turning the nut on the bottom of the spray arm 1/8 turn counterclockwise and pulling down.

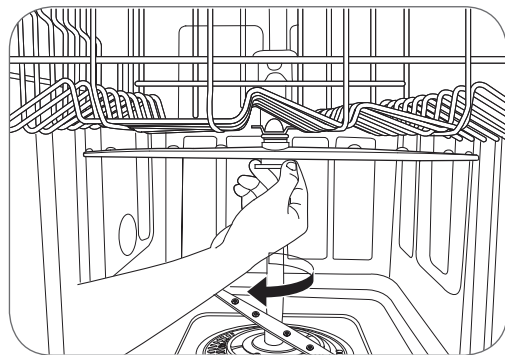

- After cleaning the upper spray arm, press it up into place. Turn the nut 1/8 turn clockwise to make sure that the nut locks back into place.

## CLEANING THE TOP SPRAY ARM

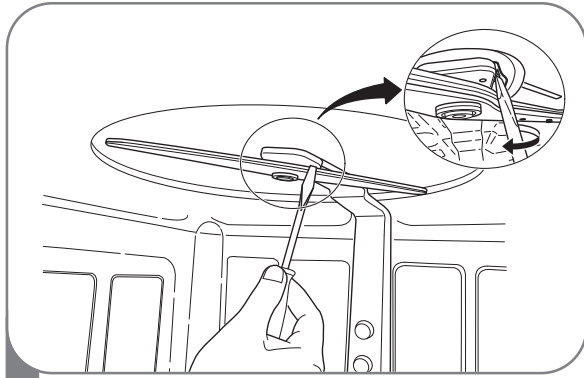

- 1 Make sure that the water jet holes are not blocked by food particles. When cleaning is necessary, use a screwdriver to release the retainer clip from the bracket that holds the top spray arm assembly to the tub.

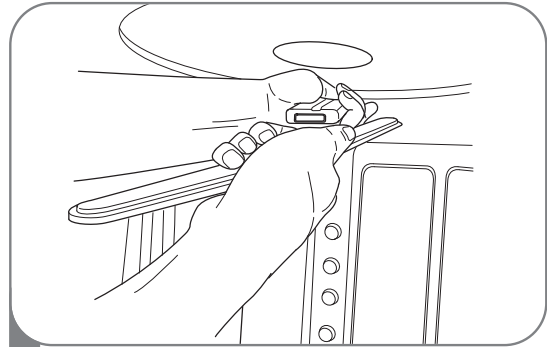

- 3 After cleaning the top spray arm, replace it. Slide it back into place and make sure the retainer clip engages.

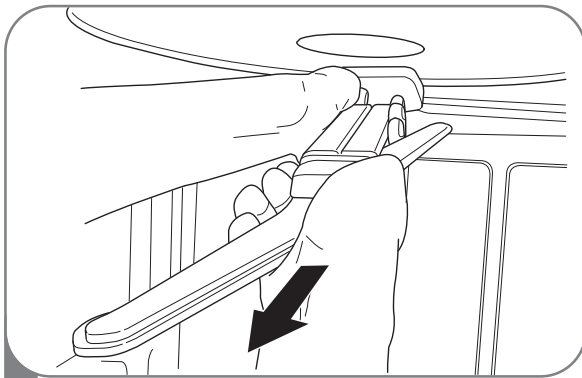

- 2 Pull the spray arm out.

## SEASONAL MAINTENANCE AND STORAGE

- If you will be absent for an extended period of time during warmer months, it is recommended that you close the water valve and unplug the power cord, or turn off the circuit breaker.
- If you will be absent for an extended period of time during colder months, and there is a possibility of freezing temperatures, it is recommended that you winterize the water supply lines and the dishwasher itself. Winterization must be performed by experienced service personnel.

## FAQs

### COMMON PRODUCT QUESTIONS

#### Is a rinse aid required to be used?

Rinse aid is strongly recommended to enhance the drying performance of the dishwasher. In order to be more energy efficient, the hybrid drying system does not utilize a heating element in order to assist in drying, so a rinse aid plays an integral role in the dry process. If a rinse aid is not used, water may remain on the dishes and the tub. Rinse aid will help to ensure that the majority of the water has been sheeted off of the dishes at the end of the rinse and that the load is ready for the dry cycle.

#### What can be done if my dishes have a cloudy, white film on them after a wash?

The cloudy film is usually caused by minerals in the water reacting with the dishwasher detergent. First, be certain not to use too much detergent. Refer to the owner's manual for recommended detergent amounts by cycle. Add an Extra Rinse or run the Power Scrub cycle. LG Dishwashers use less water than traditional dishwashers, so adding an Extra Rinse will aid in rinsing the film away. If the water supply is hard, it may be necessary to add a performance booster that addresses the hard water condition.

#### What is the Sanitary Rinse and how is it activated?

Sanitary Rinse will increase the heated rinse to approximately 161°F (72°C). The normal heated rinse temperature will vary from cycle to cycle.

#### What steps can I take to improve drying results?

Dry performance is directly affected by the amount of heat that remains in the tub after the heated rinse is performed. If your dishwasher is far away from your home's hot water heater, it may be necessary to run the hot water tap in the sink before starting a wash cycle, to ensure that cool water is purged from the hot water lines. This will ensure your dishwasher has a consistent supply of hot water from start to finish. Using the Sanitary Rinse setting will also aid in keeping the inner drum temperature and dishes hotter before drying begins.

LG dishwashers are designed to be used in conjunction with a rinse aid. Using a rinse aid will maximize the amount of water that has already been sheeted away from the dishes before the dry cycle begins. If a rinse aid is used and the performance still needs a boost, adjust the amount of rinse aid used by the indicator on the rinse aid cap. 3 is the default setting, but if necessary, set the level to 4 so more rinse aid will be used.

Allow the dishwasher to completely finish the dry cycle before opening the door. If the door is opened mid dry cycle, the heat that is necessary for the hybrid dry system to work will escape out. This will cause all of the dishes inside to remain wet once the cycle finishes.

#### What is the hybrid drying system?

The dishwasher does not rely on a heating element for the drying process; instead, it relies on the heat that is retained by the dishes and the tub during the wash and rinse cycles to turn the moisture in the tub into humidity. Warm, moist air in the dishwasher is then pulled into a condensing duct in the door by a fan. The air then cools, which causes the humidity to condense. Room temperature air is also drawn into the duct to help the air cool down faster. When this moisture condenses into a liquid, it is drained out.

#### ! NOTE

Rinse aid is required to enhance the drying performance. If no rinse aid is used, water may remain on the dishes and the tub.

#### Why is there a whistling sound?

It is important to determine how long the noise occurs and when it happens (what part of the cycle). When water is drawn into the dishwasher, a whistling noise can be heard. This is normal. If the water pressure is too high, it will be louder so it may be necessary to adjust the water valve to lower the pressure if the noise is too loud.

#### What kind of dishes can be placed in the dishwasher?

Ensure that the dishes you place in the dishwasher are dishwasher safe. Plastic dishware will not dry as effectively as glass and metal dishware. Plastic items do not retain heat as well as glass and metal dishware. Plastic cups and dishes may require some hand drying before being put away at the end of the cycle.

#### Can I perform a drain only cycle?

The dishwasher does not have a drain only function; however, the dishwasher will drain on its own for the first 45 seconds of a new cycle. To drain standing water, select a wash cycle and let it run for only 45 seconds. Then, turn the unit off and let it reset. Repeat as necessary.

#### Why does my dishwasher continuously beep if I open the door during a cycle or right after the cycle has finished?

This is normal. The dishwasher is letting you know that the interior temperatures of the unit are hot and to use caution when placing your hands inside. Once the unit has cooled down, the beeping will stop.

## PRODUCT FEATURES AND OPERATION

### **What is Child Lock and how is it activated?**

Child Lock is a feature that will prevent the controls from being changed during the cycle. It does not prevent the door from being opened or the unit from being powered off. To activate or deactivate, press the Extra Rinse and Delay Start buttons simultaneously for 3 seconds.

### **Why is "PF" showing up on the display?**

PF is not an error code indicating a malfunction. PF indicates that there was a power failure. This function protects the dishwasher in the event that the power goes out or the power to the unit is disrupted. When power is returned and a button is pushed, this will display for 10 seconds and then go away.

## INSTALLATION

### **What size is the 90° elbow?**

The 90° elbow should have a 3/8" NPT on the end that connects to the dishwasher.

### **Can I add an extension to the drain hose?**

No, an extension cannot be added.

## BEFORE CALLING FOR SERVICE

Problem	Possible Causes	Solutions
Dishwasher will not operate	Door is not completely closed.	Make sure that the door is completely closed and latched.
	Power supply or power cord is not connected.	Connect the power supply or cord properly.
	Fuse is blown or circuit breaker tripped.	Replace the fuse or reset the circuit breaker.
Dishwasher operates too long	Dishwasher is connected to cold water.	Check the water supply connection or water heater setting. (Heating cold water takes longer.)
Odor	Previous cycle was stopped before completion.	Operate the Quick cycle with detergent without loading any dishes.
	The dishwasher is not used daily.	If the dishwasher is not used daily, it is recommend to run the Quick cycle once or twice a day until you have a full load. In case odor still persists, run a vinegar rinse through a Quick cycle by putting 2 cup(500ml) of white vinegar in an upright measuring cup in the lower rack, without detergent. It is recommended to maintain according to the CARE & CLEANING section.
Water remains in tub after completion of cycle	Drain hose is kinked or clogged.	Adjust hose or clear blockage.
Spots and filming on dishes	Low water temperature.	Water supply should be at least 120°F for best wash performance.
	Wrong amount of detergent used.	Use the recommended amount of detergent.
	Overloading.	Do not overload the dishwasher.
	Improper loading.	See the Using Your Dishwasher section.
	Insufficient water pressure.	Water pressure should be between 20 and 120 psi.
	Insufficient detergent.	Add the recommended amount of detergent. See the Using Your Dishwasher section.
Rinse aid dispenser is empty.	Refill rinse aid dispenser.	
<p><b>Extremely hard water</b></p> <p>The best way to eliminate spots on your dishes is to install a whole house water softener in your home. If a water softener is already installed or you do not plan on installing one, run a Power Scrub cycle to help minimize this condition. To add an extra rinse to the cycle, select the wash cycle and then press the Extra Rinse button.</p> <p><b>To remove hard water build up in the tub</b></p> <p>Remove all dishes, silverware and the silverware holder from the dishwasher. Only the racks should remain in the tub.</p> <p>Fill a measuring cup with white vinegar, approximately 14~17 ounces (400~500mL), and place the measuring cup in the lower rack.</p> <p>Run a <b>Normal</b> cycle and select <b>Extra Rinse</b> and <b>Sanitary</b> then close the door.</p> <p>DO NOT USE DETERGENT</p> <p><b>NOTE:</b> Make sure to let the dishwasher complete the entire cycle. This cleaning method should only be done as needed.</p>		

If you have followed this troubleshooting guide and the problem persists, or if the problem you are experiencing is not listed here, please call LGE Customer Service at 1-800-243-0000(US), 1-888-542-2623(Canada).

## BEFORE CALLING FOR SERVICE

Food soil remains on dishes.	<p>Improper cycle selection.</p> <p>Water temperature too low.</p> <p>Dish washing detergent was not used.</p> <p>Low inlet water pressure.</p> <p>Water jet holes on spray arms blocked.</p> <p>Improper loading of dishes</p> <p>Filters are clogged.</p>	<p>Select correct cycle based on soil level and type of dishware being washed.</p> <p>Check water supply connection or water heater setting.</p> <p>Use recommended detergent.</p> <p>Water pressure should be between 20 and 120 psi.</p> <p>Clean the spray arms.</p> <p>Make sure dishes do not block spray arm rotation or interfere with detergent dispenser.</p> <p>Clean filters.</p>
Noise	<p>Some level of noise is normal during operation.</p> <p>The dishwasher is not level.</p> <p>Nozzle arm knocking against dishes.</p>	<p>Detergent cover opening.</p> <p>Drain pump at the beginning of drain cycle.</p> <p>Adjust leveling feet.</p> <p>Reposition the dishes.</p>
Cloudiness on glassware.	Combination of excessive detergent and hard water.	Use less detergent and use a rinse aid to minimize the problem.
Black or gray marks on dishes.	Aluminum items rubbing dishes during cycle.	Reposition the dishes.
Yellow or brown film on inside of surfaces of dishwasher.	Coffee or tea stains.	Eliminate the stain by using a stain removal product.
Dishes don't dry.	Rinse agent dispenser empty.	Check and refill the rinse agent dispenser if empty.
Lamps do not illuminate.	Power is not connected.	Connect power supply.
Sprays arms do not rotate smoothly.	Holes of spray arms are blocked by food particles.	Clean the holes of spray arms.
Upper rack is crooked.	Rack is poorly adjusted.	See the Height Adjustable Upper Rack section.
Dishwasher continuously beeps when the door is opened, during or right after a cycle has completed.	The contents of the dishwasher are hot and care should be used when placing your hands inside the dishwasher.	Close the door until the dishwasher and dishes have cooled down. The beeping will go away if the door is closed or the interior temperature has been cooled.
IE Error	Water inlet problem.	<p>Check for a clogged, kinked or frozen water inlet hose.</p> <p>Check water supply.</p>
OE Error	Drainage Problem.	Check for a clogged, kinked or frozen drain hose.
FE Error	Excessive Water supplied.	Please call an Authorized Service Center or LGE Customer Service at 1-800-243-0000 (US) 1-888-542-2623 (Canada)
HE Error	Heater circuit failure.	
tE Error	Thermistor failure or very high inlet water temperature (over 194°F)	

If you have followed this troubleshooting guide and the problem persists, or if the problem you are experiencing is not listed here, please call LGE Customer Service at 1-800-243-0000(US), 1-888-542-2623(Canada).

## SMART DIAGNOSIS™ SYSTEM

Should you experience any problems with your dishwasher, it has the capability of transmitting data to your Smart Phone using the LG Smart Laundry & DW Application or via your telephone to the LG call center.

Smart Diagnosis cannot be activated unless your dishwasher is turned on by touching the POWER button. If your dishwasher is unable to turn on, then troubleshooting must be done without using Smart Diagnosis.

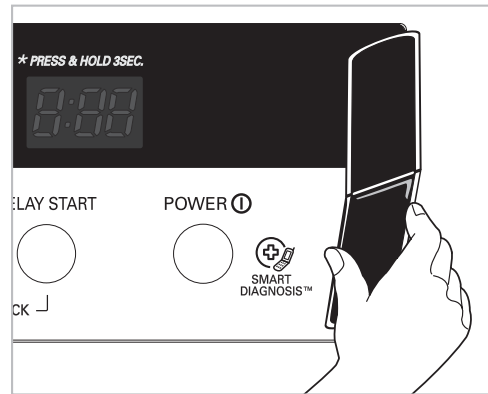

### Smart Diagnosis Using Your Smart Phone

1. Download the LG Smart Laundry & DW application on your smart phone.
2. Open the LG Smart Laundry & DW application on your smart phone.
3. Press the **Smart Diagnosis** button on your smart phone.
4. Press the **Diagnose** button on your smart phone.
5. Press the **Dishwasher** button on your smart phone.
6. Press the **RECORD** button on the smart phone and then hold the mouth piece of the smart phone near the speaker located on the panel. Hold the phone no more than one inch (but not touching) the machine.
7. Press and hold the **Sanitary** button on the dishwasher display for three seconds.

#### ! NOTE

After three seconds, the display will change from - : -- to 17 and then start counting down the remaining time.

8. With the phone held in place, press the **Smart Diagnosis** button on the phone.

#### ! NOTE

Do not touch any other buttons or icons on the display screen.

9. Keep the phone in place until the tone transmission has finished. This takes about 17 seconds and the display will count down the time.
10. When the recording is complete, view the diagnosis by pressing the **Next** button on the phone.

### Smart Diagnosis Through the Call Center

1. Call the LG call center at: (LG U.S.) 1-800-243-0000  
(LG Canada) 1-888-542-2623.
2. When instructed to do so by the call center agent, hold the mouthpiece of your phone near the speaker located on the panel. Hold the phone no more than one inch (but not touching) the machine.

#### ! NOTE

Do not touch any other buttons or icons on the display screen.

3. Press and hold the Sanitary button on the display screen for three seconds.
4. Keep the phone in place until the tone transmission has finished. This takes about 17 seconds and the display will count down the time.
5. Once the countdown is over and the tones have stopped, resume your conversation with the call center agent, who will then be able to assist you in using the information transmitted for analysis.

#### ! NOTE

Smart Diagnosis is a troubleshooting feature designed to assist, not replace, the traditional method of troubleshooting through service calls. The effectiveness of this feature depends upon various factors, including, but not limited to, the reception of the cellular phone being used for transmission, any external noise that may be present during the transmission, and the acoustics of the room where the machine is located. Accordingly, LG does not guarantee that Smart Diagnosis would accurately troubleshoot any given issue.

## DISHWASHER LIMITED WARRANTY (USA)

Should your LG Dishwasher prove to be defective in material or workmanship under normal use during the warranty period listed below, effective from the date of original consumer purchase of the product, LG Electronics will replace the defective part(s). Replacement parts will meet intended fit and function of the original part. Replacement parts are warranted for the unexpired portion of the original warranty period. This limited warranty is good only to the original purchaser of the product and effective only when used in the United States of America.

WARRANTY PERIOD	
For the Period of:	LG Will Replace:
<b>One year</b> from date of original purchase	<b>Any part</b> of the Dishwasher which fails due to a defect in materials or workmanship. During this <b>full one-year</b> of original purchase warranty, LGE will also provide, <b>free of charge</b> , all labor and on-site service to replace the defective part.
<b>Two year</b> from date of original purchase	<b>Any part of the dishwasher</b> (except as listed below) which fails due to a defect in materials or workmanship. During this <b>two-year parts warranty</b> , you will be responsible for any labor or on-site service costs.
<b>Five year</b> from date of original purchase	<b>Electronic control board and dishwasher rack</b> which fails due to a defect in materials or workmanship. During this <b>five-year parts warranty</b> , you will be responsible for any labor or on-site service costs.
<b>Ten year</b> from date of original purchase	<b>Direct Drive motor</b> which fails due to a defect in materials or workmanship. During this <b>ten-year warranty</b> , you will be responsible for any labor or on-site service costs.
<b>Limited Lifetime</b>	<b>Stainless steel door liner and tub</b> (as long as owned by the original purchaser) which fails due to a defect in materials or workmanship. During this <b>limited lifetime parts warranty</b> , you will be responsible for any labor or on-site service costs
Replacement units and repair parts may be new or factory remanufactured. Replacement units and repair parts are warranted for the remaining portion of the original unit's warranty period	

No other warranty is applicable to this product. THIS WARRANTY IS IN LIEU OF ANY OTHER WARRANTY, EXPRESS OR IMPLIED, INCLUDING WITHOUT LIMITATION, ANY WARRANTY OF MERCHANTABILITY OR FITNESS FOR A PARTICULAR PURPOSE. TO THE EXTENT ANY IMPLIED WARRANTY IS REQUIRED BY LAW, IT IS LIMITED IN DURATION TO THE EXPRESS WARRANTY PERIOD ABOVE. NEITHER THE MANUFACTURER NOR ITS U.S. DISTRIBUTOR SHALL BE LIABLE FOR ANY INCIDENTAL, CONSEQUENTIAL, INDIRECT, SPECIAL, OR PUNITIVE DAMAGES OF ANY NATURE, INCLUDING WITHOUT LIMITATION, LOST REVENUES OR PROFITS, OR ANY OTHER DAMAGE WHETHER BASED IN CONTRACT, TORT, OR OTHERWISE. Some states and/or territories do not allow the exclusion or limitation of incidental or consequential damages or limitations on how long an implied warranty lasts, so the above exclusion or limitation may not apply to you. This warranty gives you, the original purchaser, specific legal rights and you may also have other rights that vary from state to state or territory to territory.

### THIS LIMITED WARRANTY DOES NOT COVER:

1. Service calls to your home for delivery or pick-up, installation, instruction, replacement of house fuses, connection of house wiring or plumbing, or to correct unauthorized repairs.
2. Failure of product to perform during power failures and interruptions or inadequate electrical service.
3. Damage caused by transportation or handling.
4. Damage caused to the product by accident, vermin, lightning, winds, fire, floods, or acts of God.
5. Damages caused by leaky or broken water pipes, frozen water pipes, restricted drain lines, or inadequate or interrupted water supply.
6. Damages caused by inadequate supply of air.
7. Damages caused by operating the product in a corrosive atmosphere.
8. Repairs when your LG product is used in other than normal, singlefamily household use or contrary to the instructions described in the product User's Guide.
9. Damage resulting from accident, alteration, misuse, abuse, or improper installation, repair, or maintenance. Improper repair includes the use of parts not approved or specified by LG.
10. Normal maintenance as described in the User's Guide, such as cleaning or replacing filters, cleaning coils, etc.
11. Use of accessories or components that are not compatible with this product.
12. Products with altered or removed serial numbers.
13. Changes in the appearance of the product that do not affect product performance.
14. Increases in utility costs and additional utility expenses. The cost of repair or replacement under these excluded circumstances shall be borne by the consumer.

**The cost of repair or replacement under these excluded circumstances shall be borne by the consumer.**

#### For complete warranty details and customer assistance, please call or visit our website:

Call 1-800-243-0000 (24 hours a day, 365 days a year) and select the appropriate option from the menu, or visit our website at <http://us.lgservice.com>

Or by mail: LG Customer Information Center:  
P. O. Box 240007  
201 James Record Road  
Huntsville, Alabama 35813  
ATTN: CIC

#### Product Registration Information:

Model: \_\_\_\_\_

Serial Number: \_\_\_\_\_

Date of Purchase: \_\_\_\_\_

Dealer Name: \_\_\_\_\_



# DISHWASHER LIMITED WARRANTY (CANADA)

**WARRANTY:** Should your LG Dishwasher ("Product") fail due to a defect in material or workmanship under normal home use during the warranty period set forth below, LG Canada will at its option repair or replace the Product upon receipt of proof of original retail purchase. This warranty is valid only to the original retail purchaser of the product and applies only to a Product distributed in Canada by LG Canada or an authorized Canadian distributor thereof. The warranty only applies to Products located and used within Canada.

<b>WARRANTY PERIOD:</b> (Note: If the original date of purchase can not be verified, the warranty will begin sixty (60) days from the date of manufacture)			
Dishwasher		Extended Component Warranty (Parts Only) (Consumer will be charged for Labor <b>after</b> One (1) year from the date of purchase)	
Two (2) year from the date of original retail purchase	One (1) year from the date of original retail purchase	Five (5) year from the date of original retail purchase	Ten (10) years from the date of original retail purchase
Parts (internal/functional parts only)	Labor	PCB, Rack, Stainless Steel Door Liner, Tub	DD Motor

- ▶ Replacement products and parts are warranted for the remaining portion of the original warranty period or ninety (90) days, whichever is greater.
- ▶ Replacement products and parts may be new or remanufactured.
- ▶ LG Authorized Service Center warranties their repair work for thirty (30) days.

**LG CANADA'S SOLE LIABILITY IS LIMITED TO THE WARRANTY SET OUT ABOVE. EXCEPT AS EXPRESSLY PROVIDED ABOVE, LG CANADA MAKES NO AND HEREBY DISCLAIMS ALL OTHER WARRANTIES AND CONDITIONS RESPECTING THE PRODUCT, WHETHER EXPRESS OR IMPLIED, INCLUDING, BUT NOT LIMITED TO, ANY IMPLIED WARRANTY OR CONDITION OF MERCHANTABILITY OR FITNESS FOR A PARTICULAR PURPOSE, AND NO REPRESENTATIONS SHALL BE BINDING ON LG CANADA. LG CANADA DOES NOT AUTHORIZE ANY PERSON TO CREATE OR ASSUME FOR IT ANY OTHER WARRANTY OBLIGATION OR LIABILITY IN CONNECTION WITH THE PRODUCT. TO THE EXTENT THAT ANY WARRANTY OR CONDITION IS IMPLIED BY LAW, IT IS LIMITED TO THE EXPRESS WARRANTY PERIOD ABOVE. LG CANADA, THE MANUFACTURER OR DISTRIBUTOR SHALL NOT BE LIABLE FOR ANY INCIDENTAL, CONSEQUENTIAL, SPECIAL, DIRECT OR INDIRECT DAMAGES, LOSS OF GOODWILL, LOST PROFITS, PUNITIVE OR EXEMPLARY DAMAGES OR ANY OTHER DAMAGE, WHETHER ARISING DIRECTLY OR INDIRECTLY FROM ANY CONTRACTUAL BREACH, FUNDAMENTAL OR OTHERWISE, OR FROM ANY ACTS OR OMISSIONS, TORT, OR OTHERWISE.** This warranty gives you specific legal rights. You may have other rights which may vary from province to province depending on applicable provincial laws. Any term of this warranty that negates or varies any implied condition or warranty under provincial law is severable where it conflicts with provincial law without affecting the remainder of this warranty's terms.

## **THIS LIMITED WARRANTY DOES NOT COVER:**

1. Service trips to deliver, pick up, or install the product; instructing a customer on operation of the product; repair or replacement of fuses or correction of wiring or plumbing, or correction of unauthorized repairs/installation.
2. Failure of the product to perform during power failures and interruptions or inadequate electrical service.
3. Damage caused by leaky or broken water pipes, frozen water pipes, restricted drain lines, inadequate or interrupted water supply or inadequate supply of air.
4. Damage resulting from operating the Product in a corrosive atmosphere or contrary to the instructions outlined in the Product owner's manual.
5. Damage to the Product caused by accidents, pests and vermin, lightning, wind, fire, floods, or acts of God.
6. Damage resulting from the misuse, abuse, improper installation, repair, or maintenance of the Product. Improper repair includes use of parts not approved or specified by LG Canada.
7. Damage or product failure caused by unauthorized modification or alteration, or use for other than its intended purpose, or resulting from any water leakage due to improper installation.
8. Damage or Product failure caused by incorrect electrical current, voltage, or plumbing codes, commercial or industrial use, or use of accessories, components, or cleaning products that are not approved by LG Canada.
9. Damage caused by transportation and handling, including scratches, dents, chips, and/or other damage to the finish of your product, unless such damage results from defects in materials or workmanship and is reported within one (1) week of delivery.
10. Damage or missing items to any display, open box, discounted, or refurbished Product.
11. Products with original serial numbers that have been removed, altered, or cannot be readily determined. Model and Serial numbers, along with original retail sales receipt, are required for warranty validation.
12. Increases in utility costs and additional utility expenses.
13. Replacement of light bulbs, filters, or any consumable parts.
14. Repairs when your Product is used in other than normal and usual household use (including, without limitation, commercial use, in offices or recreational facilities) or contrary to the instructions outlined in the Product owner's manual.
15. Costs associated with removal of the Product from your home for repairs.
16. The removal and reinstallation of the Product if it is installed in an inaccessible location or is not installed in accordance with published installation instructions, including the Product owner's and installation manuals.
17. Accessories to the Product such as door bins, drawers, handles, shelves, etc.. Also excluded are parts besides those that were originally included with the Product.

**All costs associated with the above excluded circumstances shall be borne by the consumer.**

**For complete warranty details and customer assistance, please call or visit our website:**

Call 1-888-542-2623 (24 hours a day, 365 days a year) and select the appropriate option from the menu, or visit our website at <http://www.lg.ca>

**Write your warranty information below:**

**Product Registration Information:** \_\_\_\_\_

**Model:** \_\_\_\_\_

**Serial Number:** \_\_\_\_\_

**Date of Purchase:** \_\_\_\_\_





**LG Customer Information Center**

For inquires or comments, visit [www.lg.com](http://www.lg.com) or call;

**1-800-243-0000** USA, Consumer User

**1-888-542-2623** CANADA

**Register your product Online!**

**[www.lg.com](http://www.lg.com)**