



ITEM #0402070

SWIVEL ROCKER (SET OF 2)

MODEL #AAQ03001

Français p. 06

Español p. 11

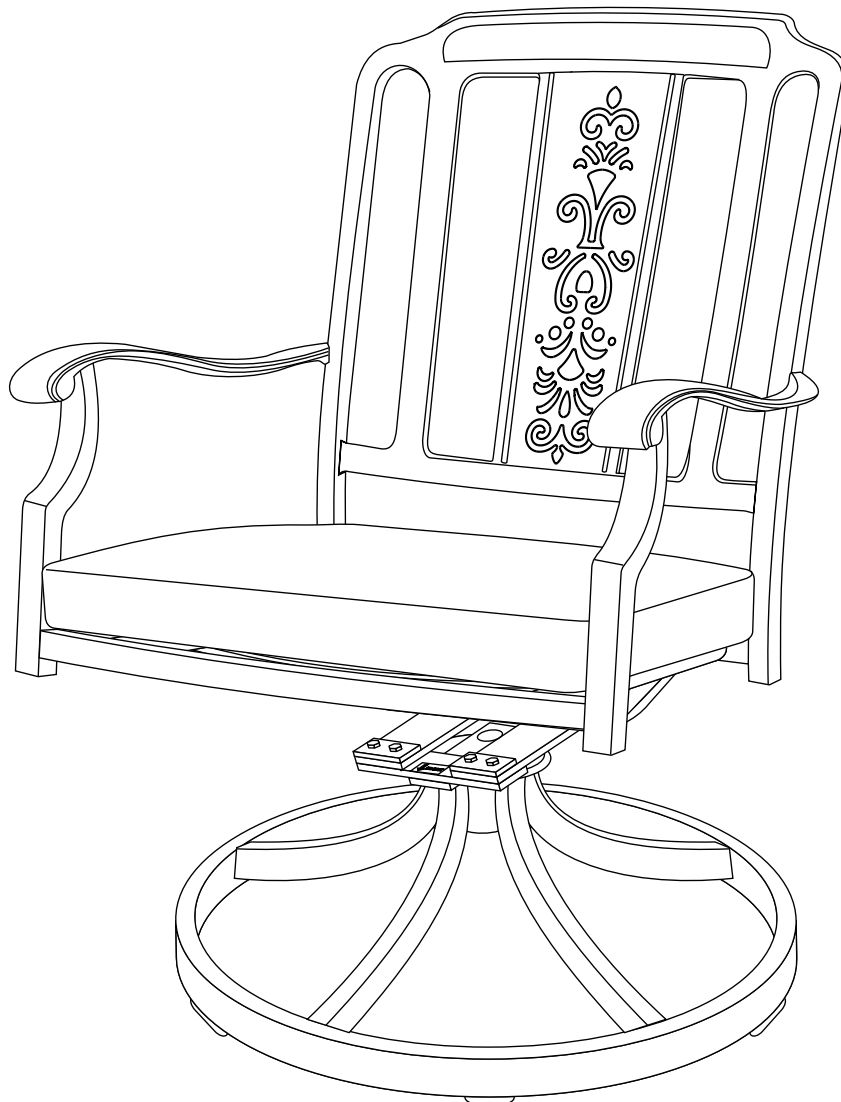

ATTACH YOUR RECEIPT HERE

Serial Number _____ Purchase Date _____



Questions, problems, missing parts? Before returning to your retailer, call our customer service department at 1-800-643-0067, 8 a.m. - 8 p.m., EST, Monday - Friday.

XXXXXX

Lowes.com/gardentreasures



PACKAGE CONTENTS

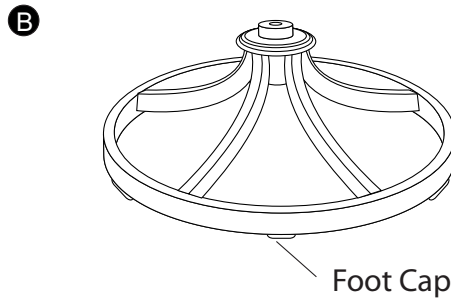
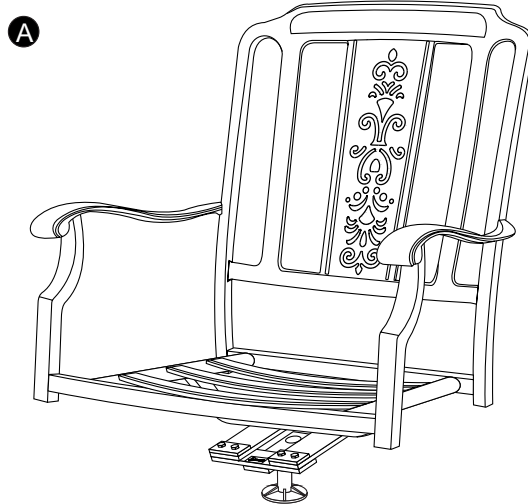

PART	DESCRIPTION	QUANTITY
A	Chair	2
B	Base	2

! SAFETY INFORMATION

WARNING

- Assemble the item on a soft, non-abrasive surface, such as carpeting, to avoid damage.

CAUTION

- This item is heavy.
- Use care when handling.
- Two adults may be required for assembly.
- 300 lb weight capacity per chair.

PREPARATION

Before beginning assembly of product, make sure all parts are present. Compare parts with package contents list. If any part is missing or damaged, do not attempt to assemble, install or operate the product.

Estimated Assembly Time: 15 minutes

No tools are required for assembly

ASSEMBLY INSTRUCTIONS

1. Remove and discard the protective cover from the shaft of the chair (A).

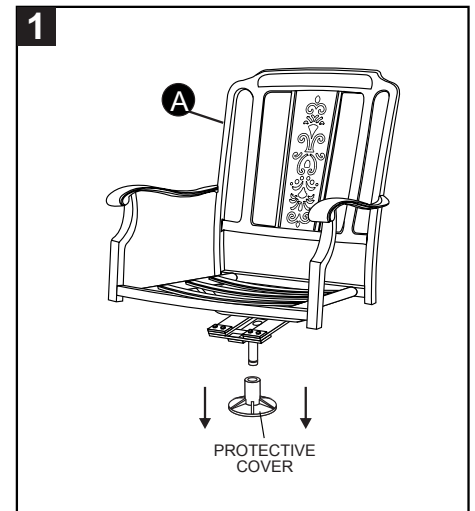

2. Attach the chair (A) to the base (B) by inserting the shaft of the chair (A) directly into the bushing portion of the base (B).

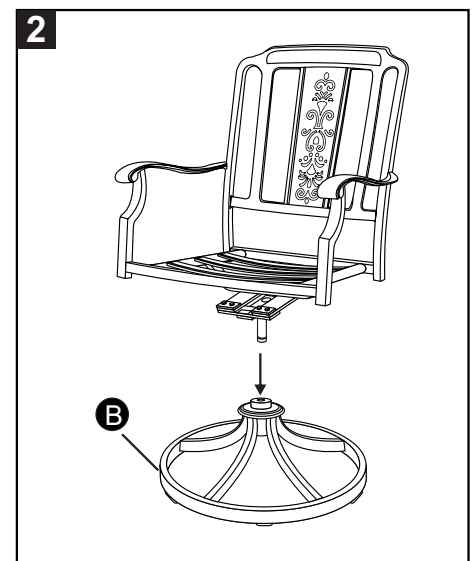

3. Make sure the chair (A) is inserted all the way into the base (B) and the base (B) is locked onto the shaft. If you experience difficulty, twist the shaft into the bushing as you insert.

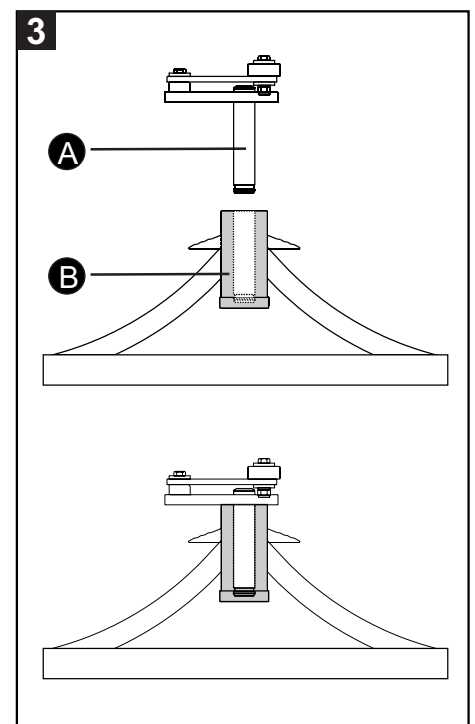

CARE AND MAINTENANCE

FRAMES

Cleaning — Use mild soap and warm water. Do not use abrasive materials, cleansers or bleach products. Rinse with clean water and dry thoroughly.

Warning: Water allowed to accumulate inside the frames could freeze and damage the frame tubing. Such damage is not covered under the warranty.

FABRIC (CUSHIONS AND SLINGS)

Cleaning — Wipe minor spills immediately. Clean fabric with mild soap, warm water and a soft cloth. Although the fabric has been treated to resist stains, over time it may be necessary to use commercially available cleaners. Always follow the manufacturer's instructions.

Maintenance — The best way to maintain the beauty of your cushions or slings is to store them in a dry area out of the elements or cover them with furniture covers (sold separately) when not in use. If your furniture is being used in areas where birds and trees are plentiful, covering your furniture is especially recommended.

LIMITED WARRANTY

This warranty is extended to the original purchaser and applies to defects in materials and workmanship of your patio furniture, provided your furniture is maintained with care and used only for personal, residential purposes.

Frames and Welds: Frames and welds are warranted to be free from defects in material or workmanship for a period of five years. One year limited fabric warranty.

Obtaining Warranty Service: To obtain warranty service, contact the manufacturer's customer service center within the relevant warranty period, and provide a copy of your dated register receipt as proof of the purchase. The manufacturer reserves the right to request photographs and/or return of the defective item for verification and quality control purposes. Contact the manufacturer's customer service center at 1-800-643-0067 for additional warranty claim details and procedures.

Limitations: This warranty is made by the manufacturer to the original purchaser only and is effective only when the item is purchased from an authorized dealer. This warranty is not transferable. Should any item fail to be as warranted, the manufacturer will, at its discretion, replace either the defective part of the item or the entire item. For discontinued models, the manufacturer reserves the right to substitute an item of its choice that is of similar style and quality. For warranty replacements based on warranty claims submitted within the first year of purchase, the manufacturer will pay all shipping and handling charges within continental North America. After the first year, shipping and handling charges are the responsibility of the claimant. Neither the manufacturer nor the dealer shall be responsible for charges associated with shipments outside continental North America at any time for any reason.

Exclusions: This warranty coverage excludes the following: any items used for commercial, contract or other non-residential purposes; clearance items, display models or items purchased "as is;" freight damage; items subject to misuse, abuse or lack of proper care and maintenance; normal wear and tear; damage caused by acts of nature, force majeure, vandalism, fire or other casualty; damage caused by improper assembly; hardware against corrosion or rusting; plastic parts.

Also excluded is loss of use or time, inconvenience, money, travel, packaging, incidental, special or consequential damages of any kind. Replacement of the defective item or part shall constitute sole and exclusive remedy for any item that is not as warranted. In no event shall the manufacturer's responsibility exceed the cost of the purchase price of the item found to be other than as warranted.

This warranty is the exclusive statement of your rights with respect to the defects in the items you have purchased and supersedes any other expressed warranty or statement, written or oral, made in connection with the purchase and sale of such item. When used herein, the term "item" when used in the singular refers to the specific item found to be defective and not the entire set of which it is a part. Some states do not allow exclusion or limitation of incidental or consequential damages, so the exclusions and limitations above may not apply to you. This warranty gives you specific legal rights, and you may also have other rights that vary from state to state.

Printed in China

Garden Treasures® is a registered trademark of LF, LLC. All rights reserved.

Lowes.com/gardentreasures 