

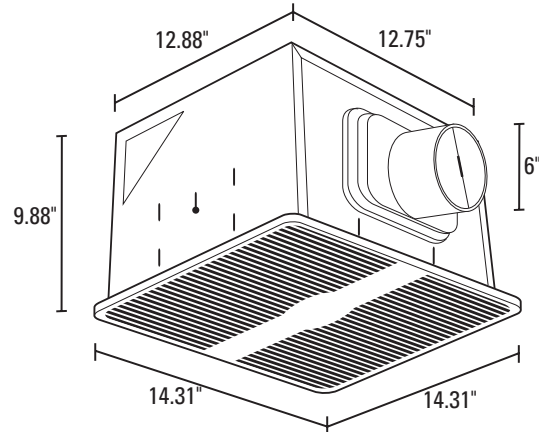

SPECIFICATIONS
ES80D
 EXHAUST FAN

80 CFM/<0.3 SONES, 30 CFM/<0.3 SONES @ 0.10 STATIC PRESSURE
HVI CERTIFIED. 120 Volts, 60 Hz, 0.3 Amps

- **Grill**
 White, polymeric grill secured in place with torsion springs; easily removed if necessary, dimensions - 14.31" x 14.31".
- **Blower Wheel**
 Balanced polymeric dual inlet blower wheel secured in place using a hex nut.
- **Motor**
 Enclosed 4 pole high efficiency, permanently split capacitor motor (PSC); life time lubrication, suitable for continuous operation. Motor bearings - sleeve. Rated 115/120 volts, 60 Hz, 0.3 amps.
- **Fan Housing**
 23 gauge galvanized steel housing. Overall dimensions: 12.88"x 12.75"x 9.88".
- **Duct Collar**
 6" round, zinc plated metal collar adapter. 6" spring loaded aluminum backdraft damper.
- **Electrical Connections**
 5" electrical knockouts provided. Easy wiring access via either internal or external wiring compartment cover.
- **Single Pack Shipping Info**
 Box Dim: 20" x 15.94" x 11.38"
 Shipping Weight: 17 lbs.



- **Unit Mounting**
 The housing will mount through drywall thickness up to .75", with a rough-in opening of 13.13" x 13". Rated for ceilings insulated to R-40. The housing will mount either between 16" or 24" on center joists, using the 2 supplied housing mounting brackets. The housing mounting brackets can be adapted for overhead mounting (hardware not provided). The unit is provided with an optionally installed ceiling flange to ensure proper building infiltration rates are maintained and that no air leaks occur between the fan housing and ceiling cutout.

PERFORMANCE										
	Static Pressure (inches of w.g.)							HVI Sones @ .1 SP	Fan Speed RPM	Power Watts
	0	0.1	0.15	0.2	0.25	0.3	0.35			
Air Flow - CFM (High Speed)	94	80	70	60	48	31	13	<0.3	743	29.4
Air Flow - CFM (Low Speed)	49	30	20	9	0	0	0	<0.3	406	21.4

PROJECT					ARCHITECT				
LOCATION					ENGINEER				
CONTRACTOR					SUBMITTED BY				DATE
FAN NUMBER	MODEL NUMBER	CFM	IN W.G.	RPM	WATTS	AMPS	SONES	QTY	OPTIONAL EQUIPMENT & REMARKS



U.S.: 820 Lincoln Drive
 West Chester, Pennsylvania 19380-4466
 Tel: (610) 692-7400 • 877-304-3785
 Fax: (610) 696-8048

Canada: 8 Edvac Road
 Brampton, Ontario L6S 5P2
 Tel: (905) 456-2033
 Fax: (905) 456-1015