

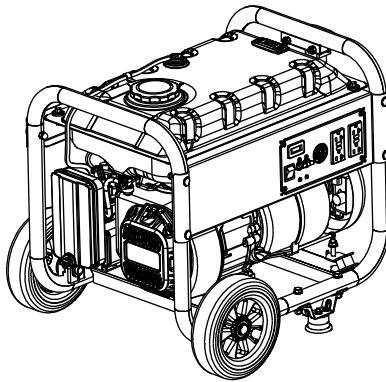

GP Series Portable Generator

Owner's Manual



MODEL: _____

SERIAL: _____

DATE PURCHASED: _____



WARNING

This product is not intended to be used in a critical life support application. Failure to adhere to this warning could result in death or serious injury. (000209a)

Register your Generac product at:
WWW.GENERAC.COM
1-888-GENERAC
(1-888-436-3722)

SAVE THIS MANUAL FOR FUTURE REFERENCE

Table of Contents

Section 1 Introduction and Safety 1

Introduction	1
Safety Rules	1
Safety Symbols and Meanings	1
Exhaust and Location Hazards	2
Electrical Hazards	2
Fire Hazards	3
Standards Index	3

Section 2 General Information and Setup 4

Know Your Generator	4
Emissions	5
Hour Meter	6
Connection Plugs	6
Remove Contents from Carton	7
Assembly	7
Add Engine Oil	8
Fuel	8

Section 3 Operation 9

Operation and Use Questions	9
Before Starting Engine	9
Prepare Generator for Use	9
Grounding the Generator When Used as a Portable	9
Know Generator Limits	9
Transporting/Tipping of the Unit	10
Starting Pull Start Engines	10
Low Oil Level Shutdown System ...	11

Section 4 Maintenance and

Troubleshooting	12
Maintenance	12
Maintenance Schedule	12
Preventive Maintenance	12
Engine Maintenance	12
Inspect Muffler and Spark Arrestor	14
Valve Clearance	14
Storage	15
Troubleshooting	16

WARNING

California Proposition 65. Engine exhaust and some of its constituents are known to the state of California to cause cancer, birth defects, and other reproductive harm. (000004)

WARNING

California Proposition 65. This product contains or emits chemicals known to the state of California to cause cancer, birth defects, and other reproductive harm. (000005)

Section 1 Introduction and Safety

Introduction

Thank you for purchasing a Generac Power Systems Inc. product. This unit has been designed to provide high-performance, efficient operation, and years of use when maintained properly.



WARNING

Consult Manual. Read and understand manual completely before using product. Failure to completely understand manual and product could result in death or serious injury. (000100a)

If any section of the manual is not understood, contact your nearest Independent Authorized Service Dealer (IASD), or contact Generac Customer Service at 1-888-GENERAC (1-888-436-3722), or www.generac.com with any questions or concerns.

The owner is responsible for proper maintenance and safe use of the equipment. Before operating, servicing or storing this generator:

- Study all warnings in this manual and on the product carefully.
- Become familiar with this manual and the unit before use.
- Refer to the Assembly section of the manual for instructions on final assembly procedures. Follow the instructions completely.

Save these instructions for future reference. ALWAYS supply this manual to any individual that will use this machine.

THE INFORMATION CONTAINED HEREIN WAS BASED ON MACHINES IN PRODUCTION AT THE TIME OF PUBLICATION. GENERAC RESERVES THE RIGHT TO MODIFY THIS MANUAL AT ANY TIME.

Safety Rules

The manufacturer cannot anticipate every possible circumstance that might involve a hazard. The warnings in this manual, and on tags and decals affixed to the unit are, therefore, not all inclusive. If using a procedure, work method or operating technique that the manufacturer does not specifically recommend, verify that it is safe for others. Also make sure the procedure, work method or operating technique utilized does not render the equipment unsafe.

Throughout this publication, and on tags and decals affixed to the generator, DANGER, WARNING, CAUTION and NOTE blocks are used to alert personnel to special instructions about a particular operation that may be hazardous if performed incorrectly or carelessly. Observe them carefully. Their definitions are as follows:

DANGER

Indicates a hazardous situation which, if not avoided, will result in death or serious injury.

(000001)

WARNING

Indicates a hazardous situation which, if not avoided, could result in death or serious injury.

(000002)

CAUTION

Indicates a hazardous situation which, if not avoided, could result in minor or moderate injury.

(000003)

NOTE: Notes contain additional information important to a procedure and will be found within the regular text of this manual.

These safety warnings cannot eliminate the hazards that they indicate. Common sense and strict compliance with the special instructions while performing the action or service are essential to preventing accidents.

Safety Symbols and Meanings

DANGER	
Using a generator indoors CAN KILL YOU IN MINUTES. Generator exhaust contains carbon monoxide. This is a poison you cannot see or smell.	
 NEVER use inside a home or garage, EVEN IF doors and windows are open.	 Only use OUTSIDE and far away from windows, doors, and vents.

000657

- Adequate, unobstructed flow of cooling and ventilating air is critical to correct generator operation. Do not alter the installation or permit even partial blockage of ventilation provisions, as this can seriously affect safe operation of the generator. The generator MUST be operated outdoors.



DANGER

Asphyxiation. Running engines produce carbon monoxide, a colorless, odorless, poisonous gas. Carbon monoxide, if not avoided, will result in death or serious injury. (000103)



⚠ DANGER

Electrocution. Water contact with a power source, if not avoided, will result in death or serious injury.

(000104)



⚠ DANGER

Electrocution. Turn utility and emergency power supplies to OFF before connecting power source and load lines. Failure to do so will result in death or serious injury.

(000116)

- It is recommended to obtain parts and service from your local IASD to keep this unit in safe working order.
- Do not operate unit on uneven surfaces, or in areas where it can be exposed to excessive moisture, dirt, dust, or corrosive vapors.



⚠ WARNING

Moving Parts. Keep clothing, hair, and appendages away from moving parts. Failure to do so could result in death or serious injury.

(000111)



⚠ WARNING

Hot Surfaces. When operating machine, do not touch hot surfaces. Keep machine away from combustibles during use. Hot surfaces could result in severe burns or fire.

(000108)

⚠ WARNING

Equipment and property damage. Do not alter construction of, installation, or block ventilation for generator. Failure to do so could result in unsafe operation or damage to the generator.

(000146)

⚠ WARNING

Do not insert any object through the air cooling slots. Generator can start at any time and could result in death, serious injury, and unit damage.

(000142)

- When working on this equipment, remain alert at all times.
- Never work on the equipment when physically or mentally fatigued.
- Never use the generator or any of its parts as a step. Stepping on the unit can stress and break parts, and may result in dangerous operating conditions from leaking exhaust gases, fuel leakage, oil leakage, etc.

	⚠ CAUTION
	Hearing protection recommended.
	PRECAUCIÓN
	Se recomienda protección auditiva.
	MISE EN GARDE
	Protection auditive recommandée.

000406

Exhaust and Location Hazards



⚠ DANGER

Asphyxiation. Running engines produce carbon monoxide, a colorless, odorless, poisonous gas. Carbon monoxide, if not avoided, will result in death or serious injury.

(000103)



⚠ DANGER

The exhaust system must be properly maintained. Do not alter or modify the exhaust system as to render it unsafe or make it noncompliant with local codes and/or standards. Failure to do so will result in death or serious injury.

(000179a)



⚠ WARNING

Asphyxiation. Always use a battery operated carbon monoxide alarm indoors and installed according to the manufacturer's instructions. Failure to do so could result in death or serious injury.

(000178a)

⚠ WARNING

Equipment and property damage. Do not alter construction of, installation, or block ventilation for generator. Failure to do so could result in unsafe operation or damage to the generator.

(000146)

- If you start to feel sick, dizzy, or weak after the generator has been running, move to fresh air IMMEDIATELY. See a doctor, as you could have carbon monoxide poisoning.

Electrical Hazards



⚠ DANGER

Electrocution. Contact with bare wires, terminals, and connections while generator is running will result in death or serious injury.

(000144)



⚠ DANGER

Electrocution. Water contact with a power source, if not avoided, will result in death or serious injury.

(000104)

- National Electric Code (NEC) requires the frame and external electrically conductive parts of the generator be properly connected to an approved earth ground. Local electrical codes may also require proper grounding of the generator. Consult with a local electrician for grounding requirements in the area.
- Use a ground fault circuit interrupter (GFCI) in any damp or highly conductive area (such as metal decking or steel work).



▲ DANGER

Electrocution. In the event of electrical accident, immediately shut power OFF. Use non-conductive implements to free victim from live conductor. Apply first aid and get medical help. Failure to do so will result in death or serious injury. (000145)

▲ WARNING

Accidental Start-up. Disconnect the negative battery cable, then the positive battery cable when working on unit. Failure to do so could result in death or serious injury. (000130)

Fire Hazards



▲ DANGER

Explosion and Fire. Fuel and vapors are extremely flammable and explosive. Add fuel in a well ventilated area. Keep fire and spark away. Failure to do so will result in death or serious injury. (000105)



▲ DANGER

Do not overfill fuel tank. Fill to 1/2 in. of top of tank to allow for fuel expansion. Overfilling may cause fuel to spill onto engine causing fire or explosion, which will result in death or serious injury. (000166)



▲ DANGER

Risk of fire. Allow fuel spills to completely dry before starting engine. Failure to do so will result in death or serious injury. (000174)

▲ WARNING

Do not insert any object through the air cooling slots. Generator can start at any time and could result in death, serious injury, and unit damage. (000142)

- Do not operate the generator if connected electrical devices overheat, if electrical output is lost, if engine or generator sparks or if flames or smoke are observed while unit is running.
- Keep a fire extinguisher near the generator at all times.

Standards Index

1. National Fire Protection Association (NFPA) 70: The NATIONAL ELECTRIC CODE (NEC) available from www.nfpa.org
2. National Fire Protection Association (NFPA) 5000: BUILDING CONSTRUCTION AND SAFETY CODE available from www.nfpa.org
3. International Building Code available from www.iccsafe.org
4. Agricultural Wiring Handbook available from www.rerc.org, Rural Electricity Resource Council P.O. Box 309 Wilmington, OH 45177-0309
5. ASAE EP-364.2 Installation and Maintenance of Farm Standby Electric Power available from www.asabe.org, American Society of Agricultural & Biological Engineers 2950 Niles Road, St. Joseph, MI 49085

IMPORTANT NOTE: This list is not all inclusive. Check with the Authority Having Jurisdiction (AHJ) for any local codes or standards which may be applicable to your jurisdiction.

Section 2 General Information and Setup

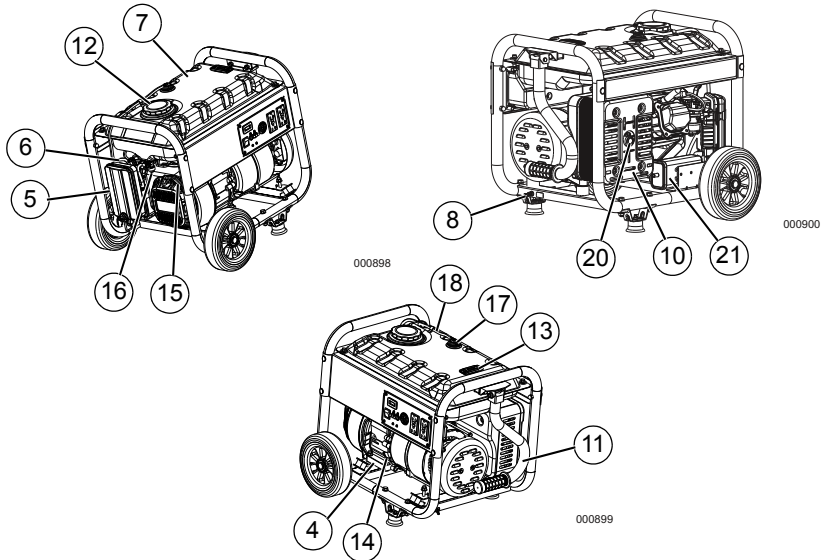

Figure 2-1. Features and Controls

TABLE 1. Generator Components

1	120 Volt AC, 20 Amp, GFCI Duplex Receptacle	21	Carbon Canister (CARB models only)
2	120/240 Volt AC, 20 Amp Locking Receptacle		
3	Circuit Breakers (AC)		
4	Oil Drain		
5	Air Filter		
6	CHOKE Knob		
7	Fuel Tank		
8	Grounding Lug		
9	RUN/STOP Switch		
10	Muffler		
11	Handle		
12	Gas Cap		
13	Fuel Gauge		
14	Oil Fill		
15	Recoil Starter		
16	Fuel Shut Off		
17	Roll Over Valve		
18	Recovery Hose		
19	Hour Meter		
20	Spark Arrestor		

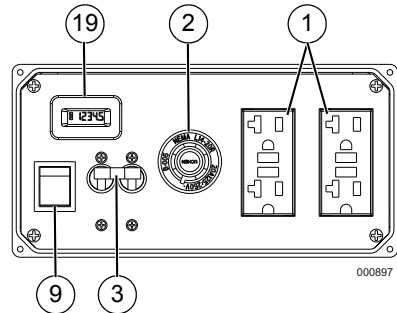

Figure 2-2. Control Panel

Know Your Generator



WARNING

Consult Manual. Read and understand manual completely before using product. Failure to completely understand manual and product could result in death or serious injury. (000100a)

Replacement owner's manuals are available at www.generac.com.

Emissions

The United States Environmental Protection Agency (US EPA) (and California Air Resources Board (CARB), for engines/equipment certified to California standards) requires that this engine/equipment complies with exhaust and evaporative emissions standards. Locate the emissions compliance decal on the engine to determine applicable standards. For emissions warranty information, please reference the included emissions warranty. It is important to follow the maintenance specifications in the manual to ensure that the engine complies with the applicable emissions standards for the duration of the product's life.

TABLE 2. Product Specifications

Generator Specifications	
Rated Power	3.3 kW**
Surge Power	3.75 kW
Rated AC Voltage	120/240
Rated AC Load Current @ 240V Current @ 120V	13.75 Amps** 27.5 Amps**
Rated Frequency	60 Hz @ 3600 RPM
Phase	Single Phase
Generator Dry Weight (assembled)	111.4 lbs. (50.5 kg)
** Operating Temperature Range: -18 deg. C (0 deg. F) to 40 Deg. C (104 Deg. F). When operated above 25 deg. C (77 deg. F) there may be a decrease in power.	
** Maximum wattage and current are subject to, and limited by, such factors as fuel Btu content, ambient temperature, altitude, engine condition, etc.. Maximum power decreases about 3.5% for each 1,000 feet above sea level; and will also decrease about 1% for each 6° C (10° F) above 16° C (60° F) ambient temperature.	
Engine Specifications	
Displacement	208 cc
Spark Plug Part No.	0H33750169
Spark Plug Type	F6TC, NGK BP6IS or Champion RN11YC
Spark Plug Gap	0.030 inch (0.76 mm)
Gasoline Capacity	3.35 gal (12.7 L)
Oil Type	See Chart in the Add Engine Oil Section
Oil Capacity	0.634 qt (0.6 L)
Run Time at 50% Load	10.2 Hours
* Go to Generac.com or contact an IASD for replacement parts.	

Hour Meter

The Hour Meter tracks hours of operation for scheduled maintenance. See [Figure 2-3](#).

- The CHG OIL display will illuminate every 100 hours. The message will flash one hour before and one hour after each 100 hour interval, providing a two hour window to perform service.
- The SVC display will illuminate every 100 hours. The message will flash one hour before and one hour after each 200 hour interval providing a two hour window to perform service.

When the hour meter is in flash alert mode, the maintenance message will alternate with elapsed time in hours and tenths. The hours will flash four times, then alternate with the maintenance message four times until the meter automatically resets.

- 100 hours - CHG OIL — Oil Change Interval (Every 100 hrs)
- 200 hours - SVC — Service Air Filter (Every 200 hrs)

NOTE: The hour glass icon will flash when the engine is running. This signifies the meter is recording hours of operation.

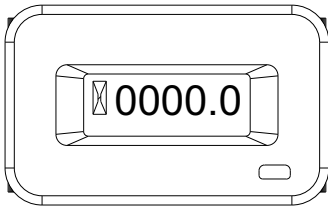

000205

Figure 2-3. Hour Meter

Connection Plugs

120 VAC, 20 Amp, GFCI Duplex Receptacle

The 120 Volt outlet is overload protected by a 14 Amp, 2-pole push-to-reset circuit breaker. See [Figure 2-4](#). Each receptacle will power 120 Volt AC, single phase, 60 Hz electrical loads requiring up to 1680 watts (1.68 kW) or 14 Amps of current. Use only high quality, well-insulated, 3-wire grounded cord sets rated for 125 Volts at 20 Amps (or greater). It also provides protection with a Ground Fault Circuit Interrupter with a press to TEST and RESET button.

NOTE: Limit length of extension cords to fifteen feet, or less, to prevent voltage drop and overheating of wires.

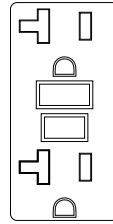

000203

Figure 2-4. 120 VAC, 20 Amp, GFCI Duplex Receptacle NEMA 5-20R

120/240 VAC, 20 Amp Twistlock Receptacle

This is a 120/240 Volt outlet protected against overload by a 14 Amp, 2-pole circuit breaker (Figure 3-6). Connect a suitable 4-wire grounded cord set to the plug and to the desired load. The cord set should be rated for 250 volts at 20 amps (or greater) if the 120/240 receptacle is used along with 120 volt receptacle. The total load drawn must not exceed the data label ratings.

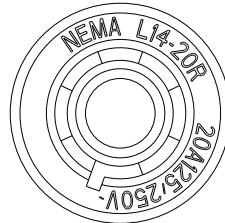

000625

Figure 2-5. 120/240 VAC, 20 Amp Receptacle

Remove Contents from Carton

1. Open carton completely by cutting each corner from top to bottom.
2. Remove and verify carton contents prior to assembly. Carton contents should contain the following:

TABLE 3. Accessories

Item	Qty.
Main Unit	1
Owner's Manual	1
Liter Oil SAE 30 with Funnel	1
Handle Assembly (A)	1
Never-flat Wheel (B)	2
Frame Foot Assembly (C)	2
Axle Pin (D)	2
Product Registration Card	3
Service Warranty	1
Emissions Warranty	1
Hardware Bag	
Hardware Bag	Qty.
Handle Bracket (E)	1
Cotter Pin (F)	2
M8-1.25 Hex Flange Nut (G)	5
M8-1.25 x 40 Hex Head Bolt (H)	2
M8-1.25 x 45 Bolt (J)	4
M8-1.25 x 55 Bolt (K)	1
Flat Washer (L)	2

3. Call Generac Customer Service 1-888-GENERAC (1-888-436-3722) with the unit model and serial number for any missing carton contents.
4. Record model, serial number, and date of purchase on front cover of this manual.

Assembly



WARNING

Consult Manual. Read and understand manual completely before using product. Failure to completely understand manual and product could result in death or serious injury. (000100a)

Call Generac Customer Service at 1-888-GENERAC (1-888-436-3722) for any assembly issues or concerns. Please have model and serial number available.

The following tools are required to install the accessory kit.

- Needle nose pliers
- Ratchet
- 12mm socket
- 12mm wrench

NOTE: The wheels are not intended for over-the-road use.

Install wheels as follows. See [Figure 2-6](#).

1. Slide axle pin (D) through the wheel (B), wheel bracket on frame, and flat washer (L).
2. Insert cotter pin (F). Bend tabs (of cotter pins) outward to lock into place.

Install frame foot as shown in [Figure 2-6](#).

1. Place frame foot assembly (C) under frame. Secure with M8-1.25 x 45 bolts (J) and M8-1.25 hex flange nut (G).

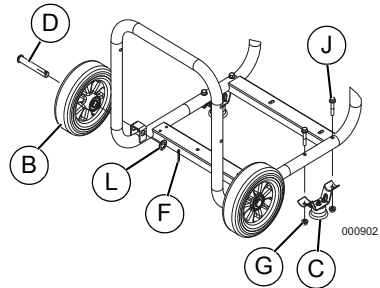

Figure 2-6. Wheel & Frame Foot Assembly

Install handle as shown in [Figure 2-7](#).

1. Install handle bracket (E) to frame with M8-1.25 x 40 bolts (H).
2. Slide M8-1.25 x 55 bolts (K) through handle bracket and handle (A). Install M8-1.25 hex flange nut (G).

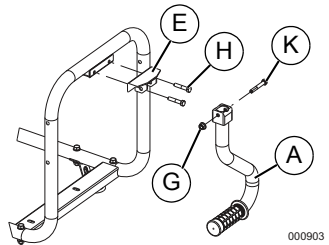

Figure 2-7. Handle Assembly

Add Engine Oil

CAUTION

Engine damage. Verify proper type and quantity of engine oil prior to starting engine. Failure to do so could result in engine damage.

(000135)

1. Place generator on a level surface.
2. Verify oil fill area is clean.
3. Remove oil fill cap and wipe dipstick clean. See [Figure 2-8](#).

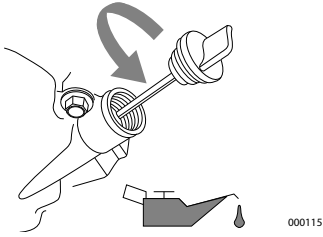

000115

Figure 2-8. Remove Dipstick

4. Add recommended engine oil as shown in the following chart.

NOTE: Use petroleum based oil (supplied) for engine break-in before using synthetic oil.

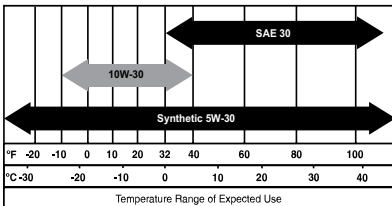

000399

NOTE: Some units have more than one oil fill location. It is only necessary to use one oil fill point.

5. Thread dipstick into oil filler neck. Oil level is checked with dipstick fully installed.
6. See [Figure 2-9](#). Remove dipstick and verify oil level is within safe operating range.

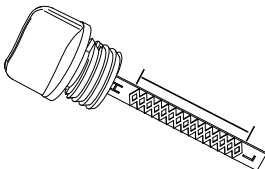

000116

Figure 2-9. Safe Operating Range

7. Install oil fill cap/dipstick and hand-tighten.

Fuel

DANGER



Explosion and Fire. Fuel and vapors are extremely flammable and explosive. Add fuel in a well ventilated area. Keep fire and spark away. Failure to do so will result in death or serious injury.

(000105)

DANGER



Do not overfill fuel tank. Fill to 1/2 in. of top of tank to allow for fuel expansion. Overfilling may cause fuel to spill onto engine causing fire or explosion, which will result in death or serious injury.

(000166)

Fuel requirements are as follows:

- Clean, fresh, unleaded gasoline.
 - Minimum rating of 87 octane/87 AKI (91 RON).
 - Up to 10% ethanol (gasohol) is acceptable (where available; non-ethanol-premium fuel is recommended).
 - DO NOT use E85.
 - DO NOT use a gas oil mix.
 - DO NOT modify engine to run on alternate fuels. Stabilize fuel prior to storage.
1. Verify unit is OFF and cooled for a minimum of two minutes prior to fueling.
 2. Place unit on level ground in a well ventilated area.
 3. Clean area around fuel cap and remove cap slowly.
 4. Slowly add recommended fuel (A). Do not overfill (B). See [Figure 2-10](#).
 5. Install fuel cap.

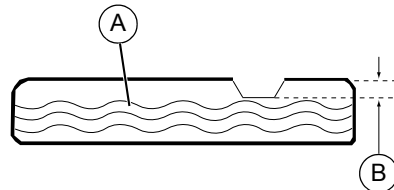

000400

Figure 2-10. Add Recommended Fuel

NOTE: Allow spilled fuel to evaporate before starting unit.

IMPORTANT NOTE: It is important to prevent gum deposits from forming in fuel system parts such as the carburetor, fuel hose or tank during storage. Alcohol-blended fuels (called gasohol, ethanol or methanol) can attract moisture, which leads to separation and formation of acids during storage. Acidic gas can damage the fuel system of an engine while in storage. To avoid engine problems, the fuel system should be emptied before storage of 30 days or longer. See the [Storage](#) section. Never use engine or carburetor cleaner products in the fuel tank as permanent damage may occur.

Section 3 Operation

Operation and Use Questions

Call Generac customer service at 1-888-GENERAC (1-888-436-3722) with questions or concerns about equipment operation and maintenance.

Before Starting Engine

1. Verify engine oil level is correct.
2. Verify fuel level is correct.
3. Verify unit is secure on level ground, with proper clearance and is in a well ventilated area.

Prepare Generator for Use



DANGER

Asphyxiation. Running engines produce carbon monoxide, a colorless, odorless, poisonous gas. Carbon monoxide, if not avoided, will result in death or serious injury. (000103)



DANGER

The exhaust system must be properly maintained. Do not alter or modify the exhaust system as to render it unsafe or make it noncompliant with local codes and/or standards. Failure to do so will result in death or serious injury. (000179a)



DANGER

Risk of fire. Do not use generator without spark arrestor installed. Failure to do so could result in death or serious injury. (000118)



WARNING

Asphyxiation. Always use a battery operated carbon monoxide alarm indoors and installed according to the manufacturer's instructions. Failure to do so could result in death or serious injury. (000178a)



WARNING

Risk of Fire. Hot surfaces could ignite combustibles, resulting in fire. Fire could result in death or serious injury. (000110)



WARNING

Hot Surfaces. When operating machine, do not touch hot surfaces. Keep machine away from combustibles during use. Hot surfaces could result in severe burns or fire. (000108)

CAUTION

Equipment and property damage. Disconnect electrical loads prior to starting or stopping unit. Failure to do so could result in equipment and property damage. (000136)

Grounding the Generator When Used as a Portable

The generator is equipped with an equipment ground connecting the generator frame and the ground terminals on the AC output receptacles (see NEC 250.34 (A)). This allows the generator to be used as a portable without grounding the frame of the generator as specified in NEC 250.34. See [Figure 3-1](#).

- Neutral bonded to frame.

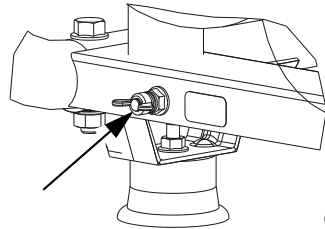

000904

Figure 3-1. Grounding the Generator

Special Requirements

Review all Federal or State Occupational Safety and Health Administration (OSHA) regulations, local codes, or ordinances that apply to the intended use of the generator.

Consult a qualified electrician, electrical inspector, or the local agency having jurisdiction:

- In some areas, generators are required to be registered with local utility companies.
- If the generator is used at a construction site, there may be additional regulations which must be observed.

Connecting the Generator to a Building Electrical System

When connecting directly to a building electrical system, it is recommended that a manual transfer switch be used. Connections for a portable generator to a building electrical system must be made by a qualified electrician and in strict compliance with all national and local electrical codes and laws.

Know Generator Limits

Overloading a generator can result in damage to the generator and connected electrical devices. Observe the following to prevent overload:

- Add up the total wattage of all electrical devices to be connected at one time. This total should NOT be greater than the generator's wattage capacity.

- The rated wattage of lights can be taken from light bulbs. The rated wattage of tools, appliances, and motors can be found on a data label or decal affixed to the device.
 - If the appliance, tool, or motor does not give wattage, multiply volts times ampere rating to determine watts (volts x amps = watts).
 - Some electric motors, such as induction types, require about three times more watts of power for starting than for running. This surge of power lasts only a few seconds when starting such motors. Make sure to allow for high starting wattage when selecting electrical devices to connect to the generator.
1. Figure the watts needed to start the largest motor.
 2. Add to that figure the running watts of all other connected loads.

The Wattage Reference Guide is provided to assist in determining how many items the generator can operate at one time.

NOTE: All figures are approximate. See data label on appliance for wattage requirements.

Table 3. Wattage Reference Guide

Device	Running Watts
*Air Conditioner (12,000 Btu)	1700
*Air Conditioner (24,000 Btu)	3800
*Air Conditioner (40,000 Btu)	6000
Battery Charger (20 Amp)	500
Belt Sander (3")	1000
Chain Saw	1200
Circular Saw (6-1/2")	800 to 1000
*Clothes Dryer (Electric)	5750
*Clothes Dryer (Gas)	700
*Clothes Washer	1150
Coffee Maker	1750
*Compressor (1 HP)	2000
*Compressor (3/4 HP)	1800
*Compressor (1/2 HP)	1400
Curling Iron	700
*Dehumidifier	650
Disc Sander (9")	1200
Edge Trimmer	500
Electric Blanket	400
Electric Nail Gun	1200
Electric Range (per element)	1500
Electric Skillet	1250
*Freezer	700
*Furnace Fan (3/5 HP)	875

*Garage Door Opener	500 to 750
Hair Dryer	1200
Hand Drill	250 to 1100
Hedge Trimmer	450
Impact Wrench	500
Iron	1200
*Jet Pump	800
Lawn Mower	1200
Light Bulb	100
Microwave Oven	700 to 1000
*Milk Cooler	1100
Oil Burner on Furnace	300
Oil Fired Space Heater (140,000 Btu)	400
Oil Fired Space Heater (85,000 Btu)	225
Oil Fired Space Heater (30,000 Btu)	150
*Paint Sprayer, Airless (1/3 HP)	600
Paint Sprayer, Airless (hand-held)	150
Radio	50 to 200
*Refrigerator	700
Slow Cooker	200
*Submersible Pump (1-1/2 HP)	2800
*Submersible Pump (1 HP)	2000
*Submersible Pump (1/2 HP)	1500
*Sump Pump	800 to 1050
*Table Saw (10")	1750 to 2000
Television	200 to 500
Toaster	1000 to 1650
Weed Trimmer	500
* Allow 3 times the listed watts for starting these devices.	

Transporting/Tipping of the Unit

Do not operate, store or transport the unit at an angle greater than 15 degrees.

Starting Pull Start Engines



WARNING

Recoil Hazard. Recoil could retract unexpectedly. Kickback could result in death or serious injury.

(000183)

CAUTION

Equipment and property damage. Disconnect electrical loads prior to starting or stopping unit. Failure to do so could result in equipment and property damage.

(000136)

1. Unplug all electrical loads from the unit's receptacles before starting engine.
2. Place generator on a level surface.
3. See [Figure 3-2](#). Open the fuel shut-off valve (A).
4. Turn engine RUN/STOP switch (B) to RUN. See [Figure 3-2](#).

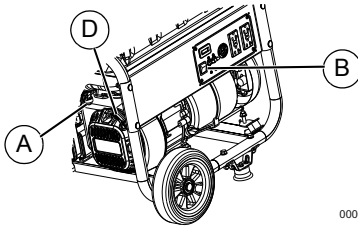

Figure 3-2. Engine Controls

5. Slide engine choke (C) to Full CHOKE position (left). See [Figure 3-3](#).

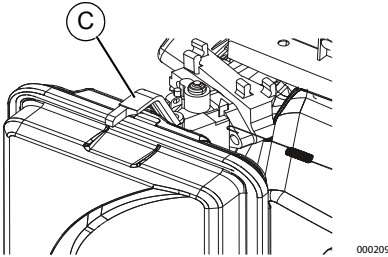

Figure 3-3. Choke Position

6. See [Figure 3-2](#). Firmly grasp recoil handle (D) and pull slowly until increased resistance is felt. Pull rapidly up and away.
7. When engine starts, move choke knob to 1/2 CHOKE position until engine runs smoothly, then fully into RUN position. If engine falters, move choke back to 1/2-CHOKE position until engine runs smoothly, then to RUN position.

NOTE: If engine fires, but does not continue to run, move choke lever to Full CHOKE and repeat starting instructions.

IMPORTANT NOTE: Do not overload generator or individual panel receptacles. These outlets are overload protected with push-to-reset circuit breakers. If amperage rating of any circuit breaker is exceeded, that breaker opens and electrical output to that receptacle is lost. Read [Know Generator Limits](#) carefully.

Generator Shut Down

CAUTION

Equipment and property damage. Disconnect electrical loads prior to starting or stopping unit. Failure to do so could result in equipment and property damage.

(000136)

1. Shut off all loads and unplug electrical loads from generator panel receptacles.
2. Let engine run at no-load for several minutes to stabilize internal temperatures of engine and generator.
3. Move RUN/STOP switch to STOP.
4. Close fuel valve.

NOTE: Under normal conditions, close fuel valve and allow generator to run carburetor bowl out of fuel. For emergencies, switch to STOP.

Low Oil Level Shutdown System

The engine is equipped with a low oil level sensor that shuts down the engine automatically when the oil level drops below a specified level. The engine will not run until the oil has been filled to the proper level.

If the engine shuts down and there is sufficient fuel, check engine oil level.

Section 4 Maintenance and Troubleshooting

Maintenance

Regular maintenance will improve performance and extend engine/equipment life. Generac Power Systems, Inc. recommends that all maintenance work be performed by an Independent Authorized Service Dealer (IASD). Regular maintenance, replacement or repair of the emissions control devices and systems may be performed by any repair shop or person of the owner's choosing. However, to obtain emissions control warranty service free of charge, the work must be performed by an IASD. See the emissions warranty.

NOTE: Call 1-888-GENERAC (1-888-436-3722) with questions about component replacement.

Maintenance Schedule

Follow maintenance schedule intervals, whichever occurs first according to use.

NOTE: Adverse conditions will require more frequent service.

NOTE: All required service and adjustments should be each season as detailed in the following chart.

At Each Use
Check engine oil level
Every 25 Hours
Clean Air Filter**
Every 100 Hours or Every Season*
Change Oil ‡
Clean/Gap Spark Plug
Every 200 Hours or Every Season
Replace Air Filter
Replace Spark Plug
Check/Adjust Valve Clearance***
‡ Change oil after first 30 hours of operation, then every season. * Change oil and oil filter every month when operating under heavy load or in high temperatures. ** Clean more often under dirty or dusty operating conditions. Replace air filter parts if they cannot be adequately cleaned. *** Check valve clearance and adjust if necessary after first 50 hours of operation and every 300 hours thereafter.

Preventive Maintenance

Dirt or debris can cause improper operation and equipment damage. Clean generator daily or before each use. Keep area around and behind muffler free from combustible debris. Inspect all cooling air openings on generator.

WARNING

Do not insert any object through the air cooling slots. Generator can start at any time and could result in death, serious injury, and unit damage.

(000142)

- Use a damp cloth to wipe exterior surfaces clean.
- Use a soft bristle brush to loosen caked on dirt, oil, etc.
- Use a vacuum to pick up loose dirt and debris.
- Low pressure air (not to exceed 25 psi) may be used to blow away dirt. Inspect cooling air slots and openings on generator. These openings must be kept clean and unobstructed.

NOTE: DO NOT use a garden hose to clean generator. Water can enter engine fuel system and cause problems. If water enters generator through cooling air slots, some water will be retained in voids and crevices of rotor and stator winding insulation. Water and dirt buildup on generator internal windings will decrease insulation resistance of windings.

Engine Maintenance

WARNING

Accidental start-up. Disconnect spark plug wires when working on unit. Failure to do so could result in death or serious injury.

(000141)

Engine Oil Recommendations

To maintain the product warranty, the engine oil should be serviced in accordance with the recommendations of this manual. For your convenience, Generac Maintenance Kits are available that include engine oil, oil filter, air filter, spark plug(s), a shop towel and funnel. These kits can be obtained from an Independent Authorized Service Dealer (IASD).

Only high-quality detergent oils classified for service SF, SG, SH, SJ or higher are recommended. DO NOT use special additives. Climate determines proper engine oil viscosity. See chart to select correct viscosity.

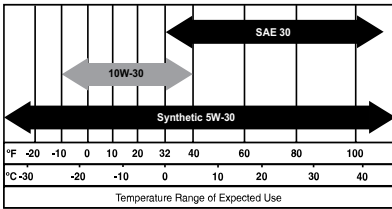

000399

Inspect Engine Oil Level



WARNING

Risk of burns. Allow engine to cool before draining oil or coolant. Failure to do so could result in death or serious injury.

(000139)

Inspect engine oil level prior to each use, or every 8 hours of operation.

1. Place generator on a level surface.
2. Clean area around oil fill.
3. See Figure 4-1. Remove oil fill cap and wipe dipstick clean.

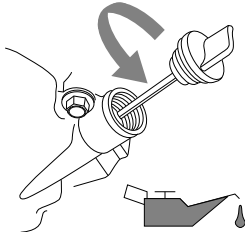

000115

Figure 4-1. Engine Oil Fill

4. Screw dipstick into filler neck. Remove dipstick and verify oil level is within safe operating range. See Figure 4-2.

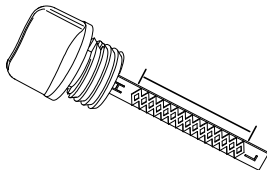

000116

Figure 4-2. Safe Operating Range

5. Add recommended engine oil as necessary.
 6. Replace oil fill cap and hand-tighten.
- NOTE:** Some units have more than one oil fill location. It is only necessary to use one oil fill point.

Change Engine Oil

WARNING

Accidental start-up. Disconnect spark plug wires when working on unit. Failure to do so could result in death or serious injury.

(000141)

When using generator under extreme, dirty, dusty conditions, or in extremely hot weather, change oil more frequently.

NOTE: Don't pollute. Conserve resources. Return used oil to collection centers.

Change oil while engine is still warm from running, as follows:

1. Place generator on a level surface.
2. Disconnect the spark plug wire from the spark plug and place the wire where it cannot contact spark plug.
3. Clean area around oil fill, and oil drain plug.
4. Remove oil fill cap.
5. Remove oil drain plug and drain oil completely into a suitable container.
6. Install oil drain plug and tighten securely.
7. Slowly pour oil into oil fill opening until oil level is between L and H marks on dipstick. DO NOT overfill.
8. Install oil fill cap, and finger tighten.
9. Wipe up any spilled oil.
10. Properly dispose of oil in accordance with all applicable regulations.

Air Filter

Engine will not run properly and may be damaged if run with a dirty air filter. Service air filter more frequently in dirty or dusty conditions. To service air filter:

1. See Figure 4-3. Turn knob (A) and remove air filter cover (B).
2. Wash in soapy water. Squeeze filter (C) dry in clean cloth (DO NOT TWIST).
3. Clean air filter cover before re-installing it.

NOTE: To order a new air filter, contact the nearest authorized service center at 1-888-GENERAC (1-888-436-3722).

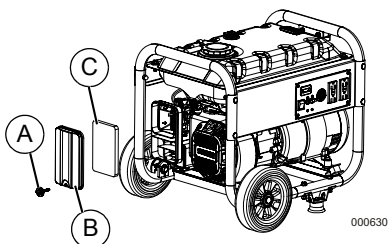

Figure 4-3. Air Filter Assembly

Service Spark Plug

To service spark plug:

1. Clean area around spark plug.
2. Remove and inspect spark plug.
3. Inspect electrode gap with wire feeler gauge and reset spark plug gap to 0.028 - 0.031 in (0.70 - 0.80 mm). See [Figure 4-4](#).

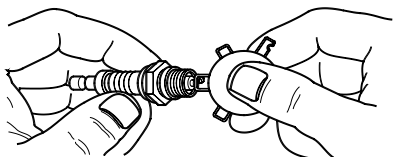

Figure 4-4. Spark Plug

NOTE: Replace spark plug if electrodes are pitted, burned or porcelain is cracked. Use ONLY recommended replacement plug. See Specifications.

4. Install spark plug finger tight, and tighten an additional 3/8 to 1/2 turn using spark plug wrench.

Inspect Muffler and Spark Arrestor

NOTE: It is a violation of California Public Resource Code, Section 4442, to use or operate the engine on any forest-covered, brush-covered, or grass-covered land unless the exhaust system is equipped with a spark arrestor, as defined in Section 4442, maintained in effective working order. Other states or federal jurisdictions may have similar laws.

Contact original equipment manufacturer, retailer, or dealer to obtain a spark arrestor designed for exhaust system installed on this engine.

NOTE: Use ONLY original equipment replacement parts.

Inspect muffler for cracks, corrosion, or other damage. Remove spark arrestor, if equipped, inspect for damage or carbon blockage. Replace parts as required.

Inspect Spark Arrestor Screen



WARNING

Hot Surfaces. When operating machine, do not touch hot surfaces. Keep machine away from combustibles during use. Hot surfaces could result in severe burns or fire. (000108)

1. Loosen clamp (A) and remove screw. See [Figure 4-5](#).
2. Inspect screen (B) and replace if torn, perforated or otherwise damaged. If screen is not damaged, clean with commercial solvent.
3. Replace spark arrestor cone (C) and screen (B). Secure with clamp (A) and screw.

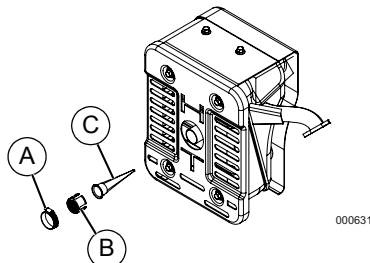

Figure 4-5. Spark Arrestor Screen

Valve Clearance

IMPORTANT NOTE: If uncomfortable about doing this procedure, or the proper tools are not available, take generator to the nearest service center to have valve clearance adjusted.

Check valve clearance after the first fifty-hours of operation. Adjust as necessary.

- Intake — $0.15 \pm 0.02\text{mm}$ (cold), (0.006 ± 0.0008 in)
- Exhaust — $0.20 \pm 0.02\text{mm}$ (cold) (0.008 ± 0.0008 in)

Storage

General

**▲ DANGER**

Explosion and Fire. Fuel and vapors are extremely flammable and explosive. Store fuel in a well ventilated area. Keep fire and spark away. Failure to do so will result in death or serious injury.
(000143)

**▲ WARNING**

Risk of Fire. Verify machine has properly cooled before installing cover and storing machine. Hot surfaces could result in fire.
(000109)

It is recommended to start and run the generator for 30 minutes, every 30 days. If this is not possible, refer to the following list to prepare unit for storage.

- DO NOT place a storage cover on a hot generator. Allow unit to cool to room temperature before storage.
- DO NOT store fuel from one season to another unless properly treated.
- Replace fuel container if rust is present. Rust in fuel will cause fuel system problems.
- Cover unit with a suitable protective, moisture resistant cover.
- Store unit in a clean and dry area.
- Always store generator and fuel away from heat and ignition sources.

Prepare Fuel System for Storage

Fuel stored over 30 days can go bad and damage fuel system components. Keep fuel fresh, use fuel stabilizer.

If fuel stabilizer is added to fuel system, prepare and run engine for long term storage. Run engine for 10-15 minutes to circulate stabilizer throughout fuel system. Adequately prepared fuel can be stored up to 24 months.

NOTE: If fuel has not been treated with fuel stabilizer, it must be drained into an approved container. Run engine until it stops from lack of fuel. Use of fuel stabilizer in fuel storage container is recommended to keep fuel fresh.

1. Change engine oil.
2. Remove spark plug.
3. Pour tablespoon (5-10cc) of clean engine oil or spray a suitable fogging agent into cylinder.

**▲ WARNING**

Vision Loss. Eye protection is required to avoid spray from spark plug hole when cranking engine. Failure to do so could result in vision loss.
(000181)

4. Pull starter recoil several times to distribute oil in cylinder.
5. Install spark plug.
6. Pull recoil slowly until resistance is felt. This will close valves so moisture cannot enter engine cylinder. Gently release recoil.

Change Oil

Change engine oil before storage. See [Change Engine Oil](#).

Troubleshooting

PROBLEM	CAUSE	CORRECTION
Engine is running, but AC output is not available.	<ol style="list-style-type: none"> 1. Circuit breaker OPEN. 2. Poor connection or defective cord set. 3. Connected device is bad. 4. Fault in generator. 5. GFCI receptacle is OPEN (if equipped). 	<ol style="list-style-type: none"> 1. Reset circuit breaker. 2. Check and repair. 3. Connect another device that is in good condition. 4. Contact IASD. 5. Correct ground fault and press reset button on GFCI receptacle (if equipped).
Engine runs well at no-load, but bogs when load is applied.	<ol style="list-style-type: none"> 1. Short circuit in a connected load. 2. Generator is overloaded. 3. Engine speed is too slow. 4. Shorted generator circuit. 	<ol style="list-style-type: none"> 1. Disconnect shorted electrical load. 2. See Know Generator Limits. 3. Contact IASD. 4. Contact IASD.
Engine will not start; or starts and runs rough.	<ol style="list-style-type: none"> 1. Fuel shut-off is OFF. 2. Dirty air filter. 3. Out of fuel. 4. Stale fuel. 5. Spark plug wire not connected to spark plug. 6. Bad spark plug. 7. Water in fuel. 8. Overchoking. 9. Low oil level. 10. Excessive rich fuel mixture. 11. Intake valve stuck open or closed. 12. Engine lost compression. 	<ol style="list-style-type: none"> 1. Turn fuel shut-off ON. 2. Clean or replace air filter. 3. Fill fuel tank. 4. Drain fuel tank and fill with fresh fuel. 5. Connect wire to spark plug. 6. Replace spark plug. 7. Drain fuel tank; fill with fresh fuel. 8. Set choke to no choke position. 9. Fill crankcase to correct level. 10. Contact IASD. 11. Contact IASD. 12. Contact IASD.
Engine shuts down during operation.	<ol style="list-style-type: none"> 1. Out of fuel. 2. Low oil level. 3. Fault in engine. 	<ol style="list-style-type: none"> 1. Fill fuel tank. 2. Fill crankcase to correct level. 3. Contact IASD.
Engine lacks power.	<ol style="list-style-type: none"> 1. Load is too high. 2. Dirty air filter. 3. Engine needs to be serviced. 	<ol style="list-style-type: none"> 1. Reduce load (see Know Generator Limits). 2. Clean or replace air filter. 3. Contact IASD.
Engine surges or stumbles.	<ol style="list-style-type: none"> 1. Choke is opened too soon. 2. Carburetor is running too rich or too lean. 	<ol style="list-style-type: none"> 1. Set choke to 1/2 CHOKE until engine runs smoothly. 2. Contact IASD.

Part No. 0K9830 Rev. C 02/02/16
©2016 Generac Power Systems, Inc. All rights reserved
Specifications are subject to change without notice.
No reproduction allowed in any form without prior written consent from Generac Power Systems, Inc.



Generac Power Systems, Inc.
S45 W29290 Hwy. 59
Waukesha, WI 53189
1-888-GENERAC (1-888-436-3722)
generac.com