

Use & Care Manual and Installation Instructions

Electric Range

Table of Contents

Important Safety Instructions - Inside Front Cover

Use and Care

Surface Cooking	1
Ceramic Glass Cooktop	2
Using your oven	3-5
Changing the Light Bulb (some models)	4
Using your Broiler	6
Clock and Time (some models)	6-7
Outlet Circuit Breaker	7
Appliance Outlet (some models)	7
Care and Cleaning	7-10

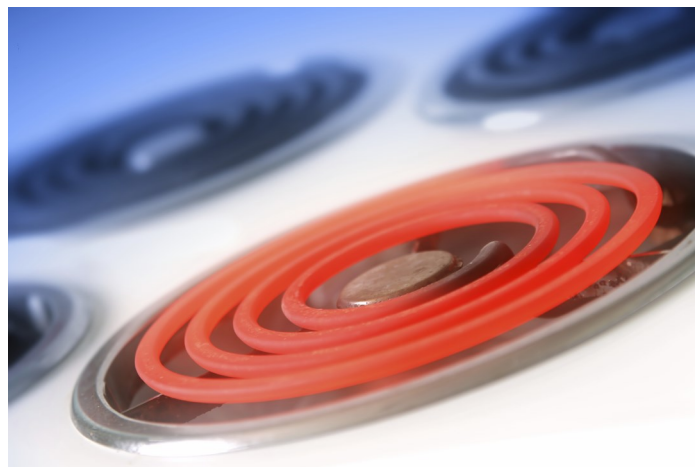

Installation

Backguard Installation	11-12
Maximum and Minimum Clearances	13
Electrical Installation	14
Anti-Tip Bracket Installation	15

Before You Call for Service 16

Note To Consumer:

Please retain this manual for future reference.

Note to Installer:

IMPORTANT - Please leave this manual and other literature with the consumer for future use.

IMPORTANT SAFETY INSTRUCTIONS

⚠ WARNING: READ ALL INSTRUCTIONS BEFORE USING THIS APPLIANCE

⚠ WARNING: If the information in this manual is not followed exactly, a fire, electrical shock or explosion may result causing property damages, personal injury or death. Use this appliance only for its intended use as described in this guide.

⚠ WARNING: Do not store or use gasoline or other flammable vapors and liquids in the vicinity of this or any other appliance.

⚠ WARNING: Installation and service must be performed by a qualified installer, service agency, or electrician.

⚠ WARNING: Before installing the range or performing any service, disconnect the range power supply at the household distribution panel by removing the fuse or switching off the circuit breaker.

⚠ WARNING



A child or adult can tip the range and be killed.

Verify the anti-tip device has been properly installed and engaged by grabbing the top rear portion of the range and pulling forward to verify the range is properly held in place.

Re-engage and check the anti-tip device if the range is moved by grabbing the top rear portion of the range and pulling forward to verify the range is properly held in place.

Do not operate the range without the anti-tip device in place and engaged.

Failure to do so can result in death or serious burns to children or adults.

To reduce the risk of the appliance tipping, it must be secured with the supplied anti-tip device. To check if this device is installed properly, grasp the top rear edge of the range and carefully attempt to tilt it forward. Re-check installation if range tilts forward more than 6 inches.

IMPORTANT SAFETY INSTRUCTIONS

1. PROPER INSTALLATION. BE SURE THE RANGE IS PROPERLY INSTALLED AND GROUNDED BY A QUALIFIED TECHNICIAN.

2. CAREFUL THOUGHT SHOULD BE GIVEN TO THE LOCATION OF THE RANGE. Avoid placement in these areas: in a main "traffic path"; in an isolated area with no counter space nearby; where open range doors could create a hazard.

3. CAUTION: KEEP CHILDREN AND PETS AWAY FROM THE RANGE AT ALL TIMES. Do Not Leave Children Alone— Children should not be left alone or unattended in an area where an appliance is in use. Children should not play with the range controls. Range surfaces are hot. Children should never be allowed to sit or stand on any part of the appliance. Do not store items of interest to children above the range or on the backsplash of a range...**SERIOUS INJURY MAY RESULT.**

4. WEAR PROPER APPAREL. Remember fabric is flammable. Loose-fitting or hanging garments should never be worn while using the range. Do not let clothing come in contact with heating elements. Don't lean on a range. If the range is near a window, use an appropriate window treatment.

5. DO NOT USE A RANGE THAT IS IN NEED OF REPAIR. Repairs should be done by a qualified technician. Poorly done repairs could result in a safety hazard. Do not replace or repair any part of the range yourself unless it is recommended in this book.

6. ⚠ WARNING: SERIOUS HAZARDS ARE ASSOCIATED WITH REACHING INTO STORAGE CABINETS ABOVE THE RANGE WHEN THE SURFACE ELEMENTS AND/OR OVEN ARE IN OPERATION. The range should not be used as a step stool to the cabinet above.

7. SERIOUS HAZARDS OR INJURIES MAY RESULT FROM THE MISUSE OF APPLIANCE DOORS OR DRAWERS. Do not allow anyone to climb, stand, hang, step, or sit on the door, or cooktop. They could damage the range or cause the range to tip over, causing serious personal injury.

IMPORTANT SAFETY INSTRUCTIONS

8. **GREASE IS FLAMMABLE AND SHOULD BE HANDLED CAREFULLY.** Avoid letting grease deposits collect around the range or in vent fans. Let quantities of hot fat, a pan of deep fat for example, cool before attempting to move it. If a grease fire occurs in a pan, put out the flame by placing a lid on the pan. DO NOT throw water on a grease fire. Use a dry chemical or foam type fire extinguisher. If a fire should occur in the oven or while broiling, turn off the oven, close the oven door and allow the food or grease to burn itself out in the oven. If smoke or fire persists, call your local fire department.
9. **NEVER USE THE RANGE FOR WARMING OR HEATING THE ROOM.** Ovens and top elements ARE NOT designed for heating use.
10. **USE ONLY DRY POT HOLDERS IN GOOD CONDITION.** Moist or damp potholders on hot surfaces may result in burns from steam. Do not let potholders touch hot heating elements. Do not use a towel or other bulky cloth.
11. **DO NOT USE ALUMINUM FOIL TO LINE SURFACE UNIT DRIP BOWLS OR OVEN BOTTOMS EXCEPT AS DESCRIBED IN THIS MANUAL.** Improper installation of these liners may result in a risk of electric shock, or fire.
12. **USE PROPER PAN SIZE.** Avoid unstable, easily tipped pans. This range is equipped with one or more surface units of different size. Select utensils having flat bottoms large enough to cover the surface unit heating element. The use of undersized utensils will expose a portion of the heating element to direct contact and may result in ignition of clothing. Proper relationship of utensil to burner will also improve efficiency.
13. **UTENSIL HANDLES SHOULD BE TURNED INWARD AND NOT EXTEND OVEN ADJACENT SURFACE UNITS-** To reduce the risk of burns, ignition of flammable materials, and spillage due to unintentional contact with the utensil, the handle of a utensil should be positioned so that it is turned inward, and does not extend over adjacent surface units.
14. **NEVER LEAVE SURFACE UNITS UNATTENDED AT HIGH OR MEDIUM HEAT SETTINGS.** Boil-over causes smoking and greasy spillovers that may start a fire.
15. **GLAZED COOKING UTENSILS-**Only certain types of glass, glass/ceramic, ceramic, earthenware, or other glazed utensils are suitable for range-top or oven service without breaking due to the sudden change in temperature.
16. **DO NOT SOAK REMOVABLE HEATING ELEMENTS.** Heating element should never be immersed in water.
17. **MAKE SURE REFLECTOR PANS OR DRIP BOWLS ARE IN PLACE.** Absence of these pans or bowls during cooking may subject wiring or components underneath the cooktop to damage.
18. **USE CARE WHEN OPENING OVEN DOOR.** Let hot air or steam escape before removing or replacing food.
19. **DO NOT HEAT UNOPENED CONTAINERS OF FOOD.** Buildup of pressure may cause the container to burst and result in serious personal harm and/or damage to the range.
20. **KEEP OVEN VENT DUCT UNOBSTRUCTED.** The oven vent duct is located under one of the rear surface elements on coil style ranges and on the front vertical surface of the backguard on ceramic smooth top ranges.
21. **PLACEMENT OF OVEN RACKS.** Always place oven racks in desired location while oven is cool. If rack must be moved while oven is hot, use a pot holder but do not let pot holder contact hot heating element in oven.
22. **CLEAN VENTILATING HOODS FREQUENTLY.** Grease should not be allowed to accumulate on hoods or filters.
23. **SHOULD FOOD FLAME WHEN COOKING UNDER A VENTILATING HOOD,** turn the hood on.
24. **KEEP ALL PLASTIC AWAY FROM THE RANGE** as plastics are vulnerable to heat.
25. **DO NOT USE THE TOP OF THE RANGE OR THE OVEN AS A STORAGE AREA.** Items stored can melt or ignite or cause burns when those items are handled.
26. **ALUMINUM FOIL WHEN USED IMPROPERLY IS A CAUSE OF MANY RANGE PROBLEMS AND MAY RESULT IN SHOCK OR FIRE HAZARDS.** See the oven and broil sections of the book for instructions for proper use.
27. **AVOID THE USE OF AEROSOL SPRAYS NEAR A RANGE, AS MOST ARE HIGHLY FLAMMABLE.**
28. **DO NOT TOUCH SURFACE UNITS, AREAS NEARBY THE SURFACE UNITS, HEATING ELEMENTS, OR THE INTERIOR SURFACE OF THE OVEN.** When cleaning the range, make sure all elements are off and cool. Even though elements are dark in color, they may still be warm enough to cause burns. Areas near surface units may become hot enough to cause burns. During and after use, do not touch, or let clothing or other flammable materials contact surface units, areas nearby the surface units, or any interior area of the oven until they have had sufficient time to cool. This includes all areas of the range, the cook-top, surfaces facing the cook-top, oven vent openings and surfaces near the openings, oven doors, window of oven doors, etc.
29. **BE SURE ALL PACKING MATERIALS ARE REMOVED FROM THE RANGE** before operating it to prevent fire or smoke damage should the packing material ignite.

SURFACE COOKING

Surface Cooking Controls

Each of the range burners has an "Infinite Control" switch that allows you to choose just the right temperature for cooking any food. The switches can be set at the numbers or any point in between. To operate, push the knob in and turn to the desired setting. Set most cooking operations on a higher setting; then turn to a lower setting to finish cooking. A glowing red element indicates that heat and energy are being wasted. The controls do not have to be set exactly on a marked setting. Use the marks as a guide and adjust the control as needed.

- HI** Quick start for cooking or bringing water to a boil. Reduce heat setting after water boils.
- 6 to 5** Frying. Browning in light weight or non- aluminum utensils.
- 4 to 3** Making sauces, pudding and frostings. To cook most foods after starting on a higher heat.
- 2 to LO** Keep foods at serving temperature. Melt chocolate and butter.

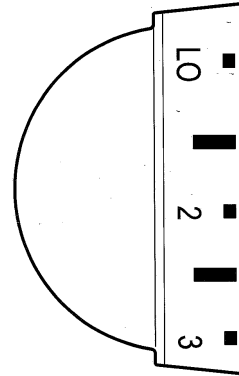

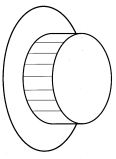
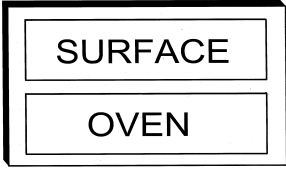
<p>SURFACE INDICATOR LIGHT</p> <p>The surface indicator light will be on whenever any of the surface elements are on. Be sure to check this light when you have finished all cooking operations.</p>	<p>20" MODELS</p> 	<p>24 AND 30" MODELS</p> 
---	---	--

ENERGY SAVING IDEAS

Pans should have tight-fitting lids to hold steam within the pans and reduce cooking time.

Pans sizes should be matched to the size of the surface element. Large pans and skillets should be used on a large element. Smaller pans should be on smaller element.

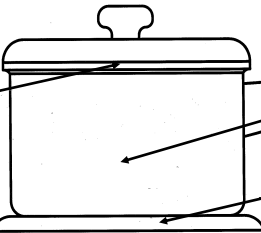

Pans should be well-balanced so that handles do not cause them to tilt.

Pan material should have good heat conduction. Medium-weight aluminum gives best results for most cooking.

To heat, cookware bottoms must be in direct contact with the element. Do not use warped cooking utensils.

COOKWARE

To assure the best cooking results match the size of the saucepan to the size of the surface unit. The pan should be flat to allow good contact with the cooking element, and should not extend over the edge of the surface unit more than **1 inch**.

Specialty pans:

- ◇ Only **flat bottom woks should be used** on surface elements. Using woks with support rings over the surface unit will cause a build-up of heat that could damage the porcelain or glass cooktop.
- ◇ **Do not** use two surface elements to heat a griddle plate or roaster.
- ◇ **Do not** use large diameter canners for frying or boiling food other than water.
- ◇ **Flat bottom canner vessels** are recommended for good heat transfer.

CERAMIC GLASS COOKTOP

A ceramic glass cooktop uses radiant surface elements. The cookware should be sized to the burner outline on the glass surface as much as possible. Although most of the heat is directed up into the defined area, the number of the burners used and the size of the cookware may lead to the whole surface of the top becoming hot enough to cause burns if touched.

CERAMIC GLASS COOKTOP RADIANT ELEMENTS

DO NOT PLACE ITEMS on top of the range, for example, pot holders, towels, salt or pepper shakers or other such items. These items could become flammable.

The radiant elements beneath the cooktop rise in temperature quickly and evenly when turned on. The element reaches its maximum temperature it will glow red. This is temporary and will vary in time based on the temperature setting. During the cooking process the element will cycle off and on maintaining an even temperature setting. Because of the residual heat from the elements and cooktop, the most efficient way to use the top burners is to turn the heat off several minutes before completing the cooking process.

HOT SURFACE INDICATOR LIGHT

The hot surface indicator light will glow when the surface cooking area heats up and will continue to glow until the top glass surface returns to a reasonable moderate temperature level. **It will continue to glow indicating a hot surface even after the range has been turned off. It is located at the right front corner of the main top.**

DO NOT COVER TWO DIFFERENT COOKING AREAS WITH A LARGE COOKING UTENSIL. THIS COULD CAUSE A FRACTURING OF THE GLASS COOKTOP.

COOKWARE MATERIAL

Various cookware may give more favorable results when cooking on a smooth top glass cooking surface:

Aluminum- Very good heat conductor resulting in good heat transfer from top to pan. Sliding aluminum pans across a glass top can leave marks on the top that resemble scratches. Most times these marks can be removed by cleaning surface.

Stainless Steel- Poor heat conductor and an uneven cooking utensil. Tends to be easy to clean.

Cast iron- Slow to heat and slow to cool. Not recommended for use on ceramic cooktops.

Porcelain or glass- Slow heat conductor. Special care must be taken because porcelain or glass utensils are capable of scratching the ceramic cooktop.

Copper bottomed- Very good heat conductor. May leave metal marks if slid across the cooktop. Can be removed during the cleaning process.

COOKWARE CARE

Before using the cooktop for the first time it is a good idea to apply a good quality ceramic top cleaner. Use a non-abrasive pad to rub the cleaner into the surface. Make sure all residual cleaner is removed prior to using. Glass ceramic cooktop cleaner will leave a protective finish that will make future cleaning easier and protect the surface from abrasion.

 **WARNING: DO NOT USE A COOKTOP CLEANER ON A HOT COOKTOP. THE FUMES CAN BE HAZARDOUS TO YOUR HEALTH AND CAN CHEMICALLY DAMAGE THE CERAMIC GLASS SURFACE.**

DO NOT:

- * Slide anything metal or glass across the cooktop.
- * Use cookware with dirt or dirt build up on bottom
- * Use your cooktop as a cutting board or work surface in the kitchen.
- * Cook foods directly on the cooktop without a pan.

CAUTION: ALUMINUM FOIL
Use of aluminum foil on a hot cooktop will damage the ceramic cooktop. Do not use thin aluminum cooking utensils or allow aluminum foil to touch the ceramic cooktop under any circumstances.

OVEN VENT

The oven is vented through one of the rear surface elements on coil element ranges. When the range is on, warm air is released through the element. This venting is necessary for proper air circulation in the oven and for good baking results. Do not block vent with aluminum foil or other material. Utensils can be placed on the surface element when the oven is on, but they may become hot.

The vent on the ceramic glass cook-top range is located on the vertical surface behind the glass top surface.

- * **DO NOT LEAVE PLASTIC ITEMS ON THE COOKTOP. THEY MAY MELT IF LEFT TOO CLOSE TO THE VENT OR BURNERS.**
- * **METAL ITEMS WILL BECOME VERY HOT IF THEY ARE LEFT ON THE COOKTOP AND COULD CAUSE BURNS.**
- * **VENT OPENINGS AND NEARBY SURFACES MAY BECOME HOT. DO NOT TOUCH THEM.**
- * **HANDLES OF POTS AND PANS ON THE COOKTOP MAY BECOME HOT IF LEFT**



OVEN COOKING

Your oven temperature is controlled very accurately using an electric oven control system. We recommend that you operate the oven for a number of weeks to become familiar with your new oven's performance.

Your new oven may heat differently than your old oven. The times and temperatures to which you have been accustomed may vary slightly because of these differences.

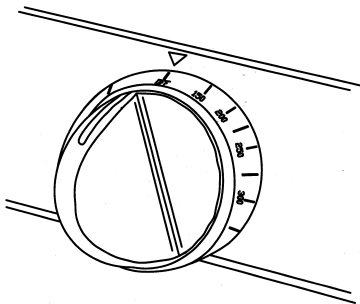

To use your oven, turn the oven control dial clockwise to the desired temperature. **DO NOT TURN TO THE BROIL SETTING AND THEN BACK TO THE DESIRED TEMPERATURE.** When the control is turned on, the bake element turns to full power until the set temperature is reached, then temperature is maintained by the bottom element cycling on and off.

- * **WARNING: WHEN THE OVEN IS HOT, THE TOP AND OUTSIDE SURFACES OF THE RANGE ALSO GET HOT.**
- * **WARNING: KEEP OVEN FREE FROM GREASE BUILDUP.**

OVEN INDICATOR LIGHT (Optional on some models)

The oven indicator light will go on when the oven control is turned on. As the oven heat reaches the selected temperature the light goes off. As the oven elements turn on and off to maintain the selected temperature during the cooking operation, the red indicator light will go on and off.

SURFACE

OVEN

INITIAL OVEN OPERATION

Slight odor or smoke from the insulation around the oven liner is normal for the first few times the oven is used. This is temporary.

PREHEAT

The oven should be preheated for most baked products (cakes, pies, bread, etc....) or when using temperatures below 225° F. Time and temperature suggestions in most cookbooks are for preheated ovens. Preheat oven by rotating the temperature control dial to the temperature needed for the product being cooked. Allow 10 to 12 minutes before putting food in the oven.

OVEN COOKING

USING ALUMINUM FOIL for baking

Use aluminum foil to catch spillovers from pies and casseroles:

Models with two oven racks:

Place the foil on the oven rack below the rack with the food. Turn up foil edges and make sure foil is about 1 inch (3 cm.) larger all around than the dish holding the food.

Models with one oven rack:

Place the foil directly under the dish holding the food. Turn up foil edges and make sure foil is about 1 inch (3 cm.) larger all around than the dish holding the food.

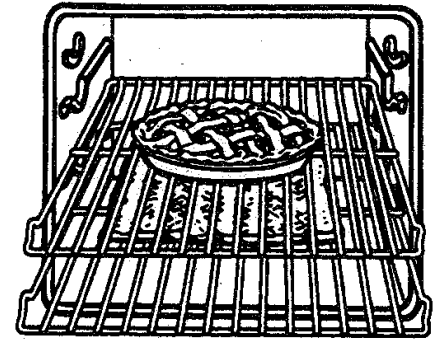

- * **Do not cover entire rack with aluminum foil. It will reduce air circulation and cause poor cooking results.**
- * **Do not line oven bottom with foil or other liners. It could affect the quality of your baking.**

BAKING

Every oven has its own personal characteristics which may be different than your old oven. The times and temperature to which you have been accustomed may vary slightly because of these differences.

Baking Hints

1. **Always follow the package instructions.** Use the recommended pan size. Cooking times may vary in high altitude areas.
2. **Baking results will be better** if pans are centered as much as possible.
3. **Do not place large cookie sheets** or pans on a rack in the bottom position. Doing so will block air circulation and may cause the oven to heat improperly.
4. **When two cakes or pies are baked at the same time**, place both pans on the same rack, using the second rack position from the bottom. **When four cakes or pies are baked at the same time**, place two pans on each rack, using the second and fourth rack positions from the bottom.

PAN PLACEMENT

For each cooking and proper browning, there must be enough room for air circulation in the oven. Baking results will be better if baking pans are centered as much as possible rather than being placed to the front or to the back of the oven.

Pans should not touch each other or the walls of the oven. Allow 1 to 1½-inch space between pans as well as from the back of the oven, the door and the sides. If you use two shelves, stagger the pans so one is not directly above the other.

OVEN LIGHT (Optional on some models)

The switch located at the right of the control panel turns the oven light on and off.

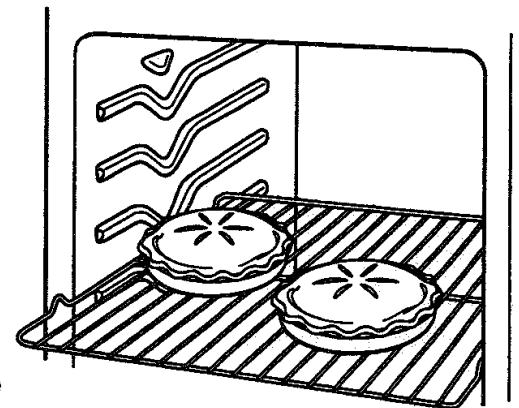

CHANGING THE OVEN LIGHT BULB

1. Gloves should be worn to protect your hands when changing the bulb.
2. Disconnect the power to the range at the main breaker.
3. Unscrew the light bulb counterclockwise.
4. Replace the bulb with a 40-watt appliance bulb.
5. Reconnect the power to the range.

OVEN RACKS (Some models may come with only one oven rack.)

The racks are designed with stop locks. When placed correctly on the rack supports, they will stop before coming completely out of the oven and will not tilt when you are removing food from them or placing food on them.

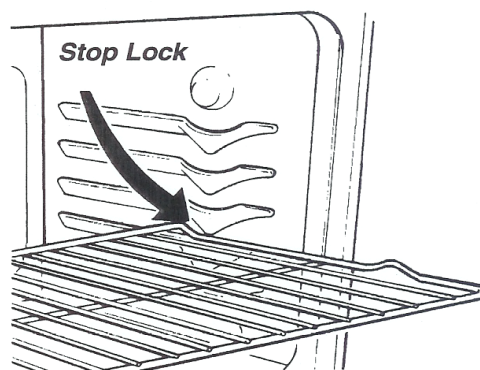
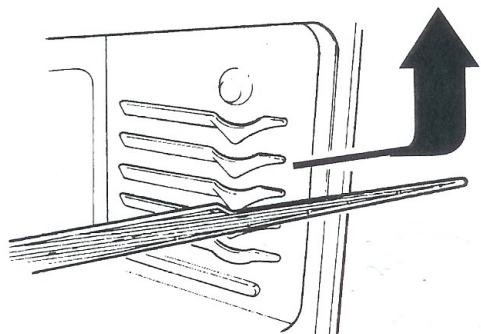

To remove the racks from the oven, pull them toward you, tilt front end upward and pull them out.

- * **DO NOT USE THE OVEN COMPARTMENT FOR A STORAGE AREA. ITEMS STORED IN THE OVEN CAN IGNITE.**
- * **PLACE OVEN RACKS IN DESIRED POSITION WHILE THE OVEN AND OVEN RACKS ARE COOL.**

ROASTING

Roasting is oven cooking of tender cuts of meat and poultry. Low temperature roasting cooks meat to an appetizing brown without undue loss of juices and minimum shrinkage. It also reduces spattering and keeps oven cleanup at a minimum.

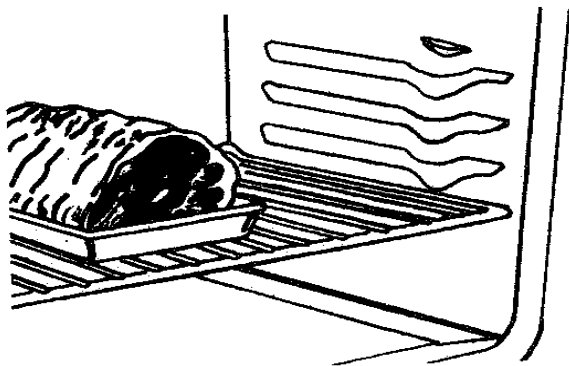

- * **STAND AWAY FROM THE RANGE WHEN OPENING THE DOOR OF A HOT OVEN. THE HOT AIR AND STEAM WHICH ESCAPE CAN CAUSE BURNS.**
- * **PULLING OUT RACK TO THE RACKSTOP IS A CONVENIENCE IN LIFTING HEAVY FOODS.**
- * **DO NOT PLACE HEAVY FOOD ON OVEN DOOR.**
- * **WHEN USING COOKING OR ROASTING BAGS IN OVEN, FOLLOW THE MANUFACTURER'S DIRECTIONS.**

For Best Results:

1. Check weight of meat and place, fat side up, on roasting rack in a shallow pan.
2. Place on oven shelf in middle or lower position. Close oven door.
3. Set oven control at 325^o F.
4. Follow time suggested on the roasting chart in your favorite cookbook. These times are only a guide as meat cuts will differ.
A meat thermometer is the only accurate test for doneness.

BROILING

Broiling is a fast method for cooking tender cuts of meats, poultry, ham and fish by direct heat from a broiler element. Foods are placed under the upper heating element of the oven. Broiling results and timing depend upon the distance between the food and the broiler element.

Broil with the door closed, for a cleaner, cooler kitchen. The smoke from broiling is consumed as it is drawn over a rod-type broiler element. After broiling, the dial must be turned to "OFF" before baking.

Broiling time vary, so watch closely. Time depends on thickness and aging of meat, fat content and the doneness preferred. Frozen foods require additional time for cooking.

BROILING CHART

	Rack Position	Cooking Time	
		First Side	Second Side
Steaks 1 inch thick Rare Well Done	2nd or 3rd from top Lowest rack position	6 to 8 min. 12 to 14 min.	3 to 4 min. 10 to 12 min.
Ground Beef Patties 1 inch thick Rare Well Done	2nd or 3rd from top Lowest rack position	6 to 8 min. 10 to 12 min.	3 to 4 min. 6 to 8 min.
Chicken	Lowest rack position	30 to 35 min. total cooking time. Turn Frequently.	
Fish	Lowest rack position	22 to 30 min. total cooking time. Turn whole fish once. Do not turn fillets.	
Cooking times given are approximate and should be used as a guide. Variables in meats and personal preferences may make changes necessary.			

- * **DO NOT USE THE BROILER PAN WITHOUT ITS INSERT. NEVER COVER THE BROILER INSERT OPENINGS WITH ALUMINUM FOIL. IF THE INSERT IS COVERED BY ALUMINUM FOIL, FAT CANNOT DIP AWAY FROM THE MEAT AND MAY EASILY IGNITE.**
- * **IF YOU SHOULD HAVE A GREASE FIRE WHILE BROILING, TURN OFF THE BROILER AND KEEP THE DOOR CLOSED TO CONTAIN THE FIRE UNTIL IT BURNS OUT.**
- * **ALWAYS REMOVE THE BROILER PAN AS SOON AS THE BROILER PAN COOLS. GREASE LEFT IN THE PAN CAN CATCH FIRE IF THE OVEN IS USED WITHOUT REMOVING THE GREASE FROM THE BROILER PAN.**
- * **WHEN BROILING, IF MEAT IS TOO CLOSE TO THE FLAME, THE FAT MAY IGNITE.**

CLOCK AND TIMERS



TO SET TIME OF DAY: Depress "CLOCK" button (a tone will sound. Depress "UP" button to set the time up, or depress "DOWN" button to set the time down.

Tapping the "UP" or "DOWN" button will increase or decrease the time by 1 min. Holding in the "UP" or "DOWN" button will increase or decrease the time in 10 minute intervals.

After the correct time is set, depress the "CLOCK" button (a tone will sound) or wait 7 seconds and the correct time will be set.

TO SET TIMER: Depress "TIMER" button (a tone will sound.) Depress "UP" button to set the time up, or depress "DOWN" button to set the time down. Tapping the "UP" or "DOWN" will increase or decrease the time by 1 minute. Holding in the "UP" or "DOWN" button will increase or decrease the time in 10 minute intervals. 7 seconds after the last programming input, the timer

TO SET TIMER continued When 1 minute is remaining on the timer, a one second tone will sound. When the timer reaches zero (00:0), there will be three tones 1 second apart, then a tone every 10 seconds for 10 min.

NOTE: The colon flashes when the timer is active whether the timer or the time of day is displayed. To display the time of day when in the timer mode, depress the "CLOCK" button. To cancel, the timer, depress the "TIMER" button once when the timer is displayed or twice when the time of day is displayed.

TIME OF DAY CLOCK-No Timer

TO SET TIME OF DAY: Depress hour set button until the correct hour of the day is displayed on the clock. Depress minute set button until the correct minute of the day is displayed.

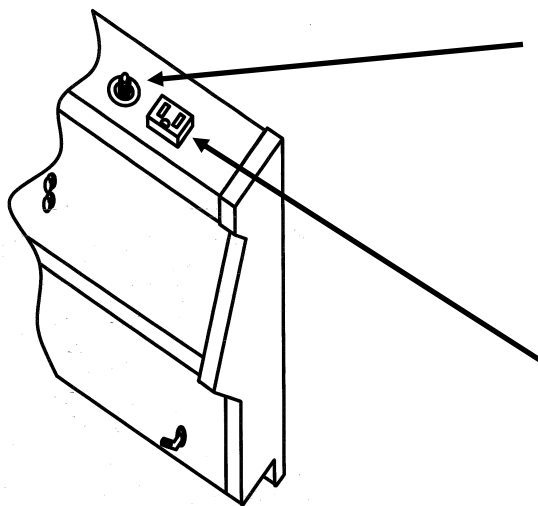
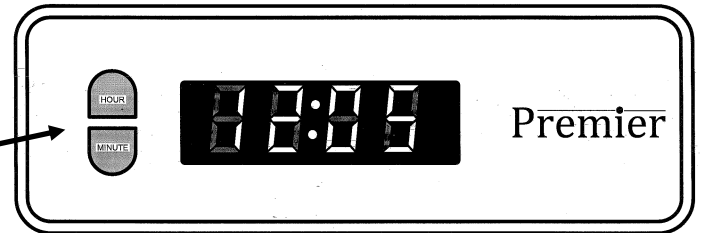

OUTLET CIRCUIT BREAKER - Optional on some models

The appliance outlet circuit breaker is located next to the appliance outlet on the backguard. The circuit breaker is rated for 12 amps. To reset the circuit breaker, unplug the appliance from the outlet and push the reset button in the center of the circuit breaker.

APPLIANCE OUTLET - Optional on some models

The appliance outlet is located on the top of the range backguard. It may be used to run portable appliances placed on countertop beside the range.

CARE AND CLEANING

PORCELAIN OVEN INTERIOR- Porcelain has a smooth finish, and is a type of glass fused to metal. With proper care, the porcelain enamel walls in these ovens will retain their good looking finish for many years.

Food soil that is allowed to harden and bake on can be difficult to remove.

Clean the oven before it is entirely cool (not while it is hot) with detergent and water, using a soap-filled steel wool pad on burned spots. Rinse and wipe dry.

Commercial oven cleaners may be used on oven interior. After using cleaners, thoroughly rinse the oven with a solution of one tablespoon vinegar to one cup water. Oven cleaners can coat or damage the temperature sensing bulb (long tube in the oven) so that it will not sense temperature correctly. If you are using an oven cleaner, try to avoid any contact with the rod-shaped bulb of the thermostat. Be sure that any residue that touches the bulb is carefully remove.

Oven racks are removed by pulling forward, tilting and lifting up. Racks may be washed with detergent and water. Scour heavily soiled areas with a soap-filled steel wool pad. Oven windows may be washed with a damp cloth dipped in detergent and warm water, or a solution of baking soda and water.

⚠ WARNING: KEEP APPLIANCE AREA CLEAR AND FREE FROM COMBUSTIBLE MATERIALS, GASOLINE AND OTHER FLAMMABLE VAPORS AND LIQUIDS.

CARE AND CLEANING

PORCELAIN ENAMEL COOKTOP AND BODY PIECES

If there is a spill-over when the range is warm, wipe up with a dry cloth or paper towel. After the range is cool, finish cleaning with warm water and detergent, or wash with a solution of baking soda dissolved in warm water. Rinse with clear warm water and dry with a soft cloth.

CERAMIC COOKTOP

Put a few drops of glass-ceramic cooktop cleaner directly on the cooktop. Use a non-abrasive cleaning pad and a paper towel to clean the surface of the top. If soils remain, carefully scrape soils with a razor blade, holding blade at about a 30degree angle to the surface.

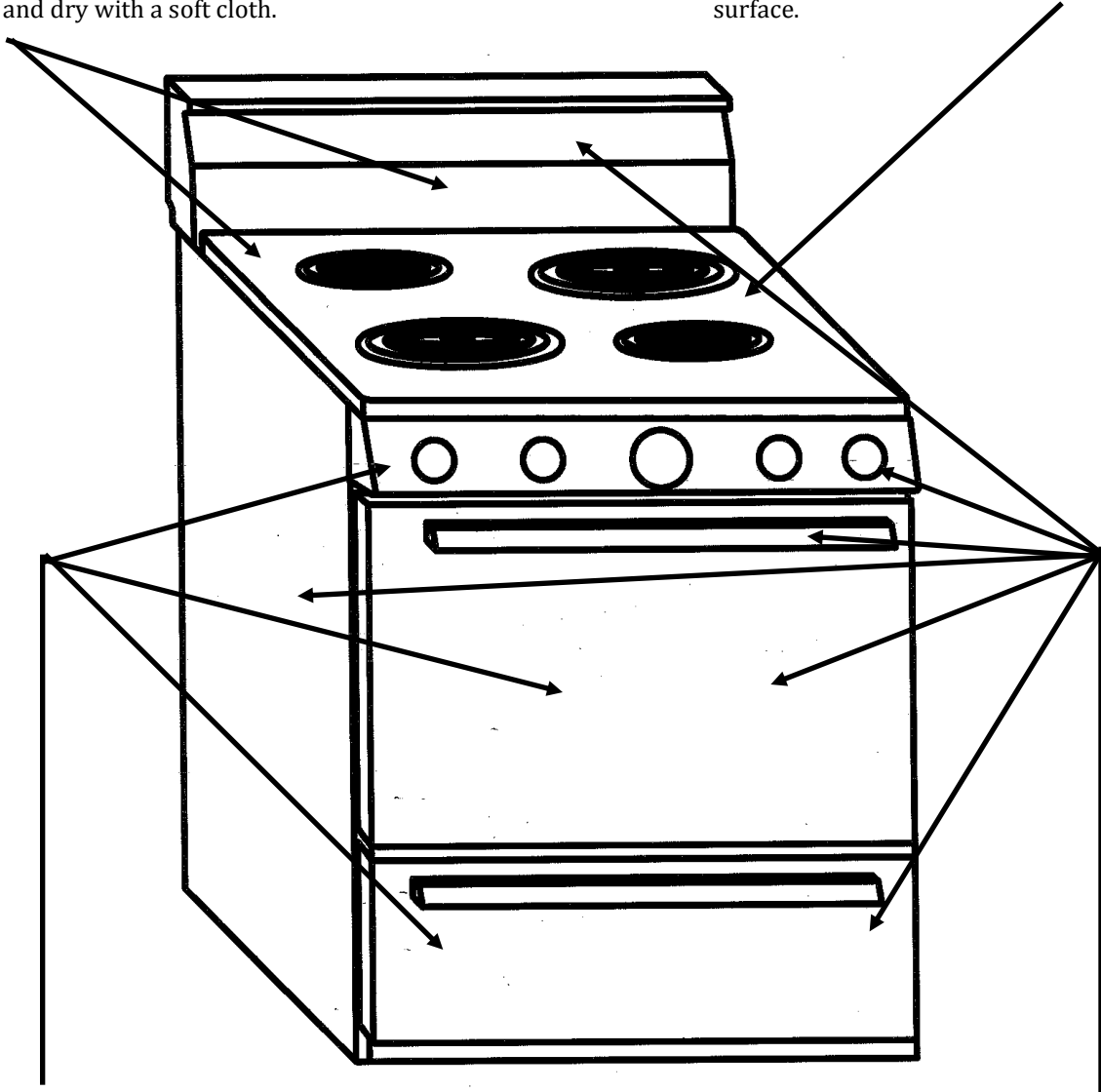

STAINLESS STEEL, CHROME TRIM PIECES

Use a mixture of mild detergent and hot water to remove light soil. Rinse with a damp cloth and wipe dry. Cleaners made especially for stainless steel or chrome are recommended. Bluish stains on these materials are caused by overheating and cannot be removed. **Do not use steel wool, abrasives, ammonia, acids or commercial oven cleaners.**

GLASS, PAINT AND PLASTIC

(knobs, decorative trim, etc.)- These materials are used in areas where heavy soil will not accumulate. Use detergent and damp cloth to clean the control panel. Rinse with a damp cloth and dry. Be sure to wring excess moisture from the cloth when wiping around controls. Excess water in or around the controls may cause damage to the appliance. **Do not use steel wool, abrasives, ammonia, acids or commercial oven cleaners.**

CARE AND CLEANING

OVEN AND SURFACE HEATING ELEMENTS

Both the oven and the surface elements clean themselves when they are turned on. Food spilled on a hot element will burn off.

TO REMOVE SURFACE ELEMENTS:

Surface elements can be removed to make cleaning easier. **To avoid the possibility of a burn or electric shock, always be certain that the controls for all surface units are at the "OFF" position and all coils are cool before attempting to lift or remove a surface unit.** To remove, lift up edge of element opposite terminal. Lift up and pull out to clear the reflector pans.

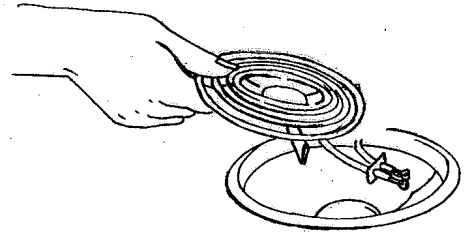

⚠ WARNING: DO NOT IMMERSE A SURFACE ELEMENT IN WATER.

REFLECTOR PANS

Wash reflector pans in hot, sudsy water or in the dishwasher. Rinse and dry while still warm. Hard-to-remove soil can be removed using a nylon scrubber and a mild detergent and water. **DO NOT USE STEEL WOOL.**

TO REMOVE REFLECTOR PANS:

The chrome reflector pans are removed by first removing the element, (See: To Remove Surface Elements) and then lifting the reflector pan out.

CONTROL KNOBS

Clean up any spills or splatters on the knobs with a damp cloth. Remove heavier soil with soapy water. The control knobs may be removed for easier cleaning by pulling straight of the stem. Wash the knobs in soap and water but do not soak.

OVEN BOTTOM

The oven bottom is not removable. To clean the oven bottom surface, the oven element can be lifted to allow for cleaning beneath the element.

⚠ WARNING: WHEN CLEANING THE OVEN SECTION MAKE SURE THE BAKE AND BROIL ELEMENTS ARE OFF AND COOL. EVEN THOUGH THE ELEMENTS ARE DARK IN COLOR, THEY MAY STILL BE WARM ENOUGH TO CAUSE BURNS.

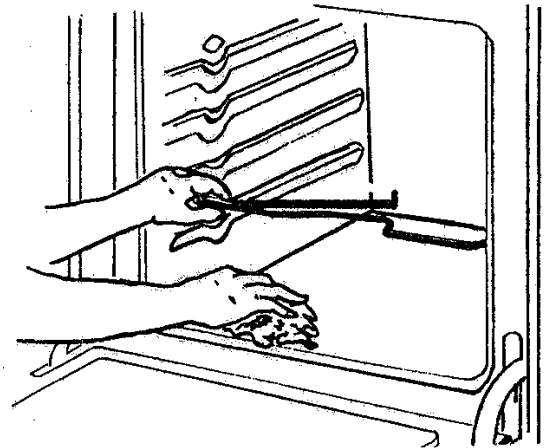

BROIL PANS (in some models)

Clean using hot, sudsy water, a mild abrasive cleaner, a soap filled abrasive pad or commercial oven cleaner, following the manufacturer's instructions.

CARE AND CLEANING

CLEANING BROILER PAN (Some Models)

Clean using hot, sudsy water, a mild abrasive cleaner, a soap filled abrasive pad or commercial oven cleaner, following the manufacturer's instructions.

LIFT-UP COOKTOP

To make cleaning easier, the entire cooktop may be lifted up and supported in the up position.

⚠ WARNING: BE SURE ALL SURFACE UNITS ARE TURNED OFF BEFORE RAISING THE COOKTOP.

The
re-

cessed area beneath the lift-up cooktop may be wiped clean with a hot soapy rag.

DO NOT USE STEEL WOOL PADS, COMMERCIAL OVEN CLEANER, SILICONE OVEN SPRAYS, COARSE PADS OR COARSE BRUSHES ON THE RECESSED AREA BENEATH THE COOKTOP.

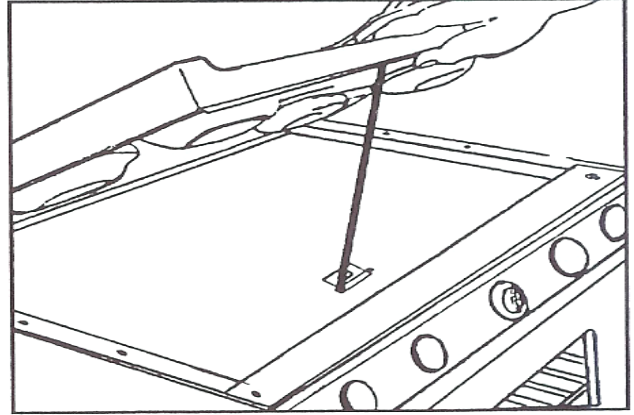

STORAGE DRAWER (on some models)

The storage drawer can be removed for easier cleaning. To remove:

1. Pull drawer out to the stop position.
2. Push up under the center of the drawer while pulling the drawer out to allow the drawer stop to clear the range front frame.
3. Drawer will slide out free of range.

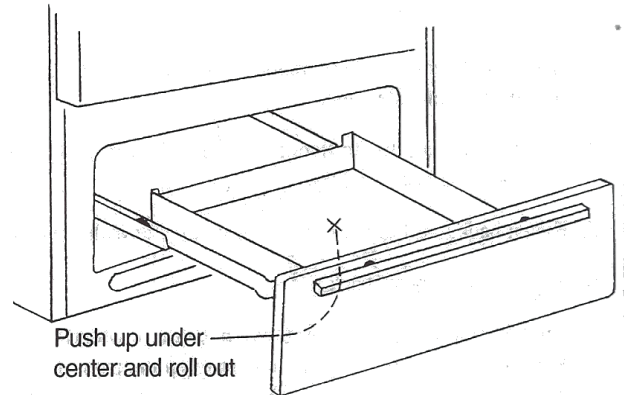

To replace drawer, slide drawer back in on tracks until the drawer stop hits the range front, then push up under center of drawer while sliding drawer in.

DO NOT USE STEEL WOOL PADS, COMMERCIAL OVEN CLEANER, SILICONE OVEN SPRAYS, COARSE PADS OR COARSE BRUSHES ON THE STORAGE DRAWER.

INSTALLATION INSTRUCTIONS

PORCELAIN BACKGUARD INSTALLATION (Illustration A)

1. Move range main top forward about two inches and position backguard near the backguard support.
 2. If backguard has a clock, connect plug **(F)** from backguard to plug **(F)** from back of range and push plug assembly down through square-out in the backguard support.
 3. Attach backguard to backguard support with (4) **(A)** wing nuts.
 4. On the front of the backguard, two nuts are provided on the threaded hinge pins. Remove these nuts. Place the main top on the pins. Lift the front of the main top and thread the two nuts on the hinge pins. Push the main top down into the normal position.
-

FORMED METAL ENDS BACKGUARD INSTALLATION– Ranges with coil top elements (Illustration B)

1. Move range main top forward about two inches.
 2. Remove range outer back.
 3. Lower backguard down on range main sides, lining up holes in top and rear flanges of main side panels.
 4. Fasten backguard to top flange of main side with (2) **(C)** bolts and (2) **(E)** nuts as shown and fasten tightly.
 5. Fasten backguard to back flange of main sides with (2) **(D)** screws.
 6. Replace range outer back.
 7. On the front of the backguard, two nuts are provided on the threaded hinge pins. Remove these nuts. Place the main top on the pins. Lift the front of the main top and thread the two nuts on the hinge pins. Place the main top in the normal position.
-

FORMED METAL ENDS BACKGUARD INSTALLATION– Ceramic glass top elements (Illustration C)

1. Place backguard on top of main sides and slide the backguard onto the threaded pins on the back edge of the range top.
 2. Roll the backguard forward to allow access to the threaded studs on the range main top. Thread (2) **(A)** wingnuts onto the threaded studs.
 3. Fasten backguard to back flange of main sides with (2) **(D)** screws.
-

THERMOPLASTIC END CAP BACKGUARD INSTALLATION (Illustration D)

1. Move range main top forward about two inches and position backguard near the backguard support.
2. If backguard has a clock, connect plug **(F)** from backguard to plug **(F)** from back of range and push plug assembly down through square cut-out in the backguard support.
3. Position backguard down over backguard support and screw (2) **(B)** black sheet metal screws through backguard end caps into support ends.
4. From rear of unit, screw (2) **(D)** long sheet metal screws through back of backguard end caps into backguard support.
5. On the front of the backguard, two nuts are provided on the threaded hinge pins. Remove these nuts. Place the main top on the pins. Lift the front of the main top and thread the two nuts on the hinge pins. Replace the main top to the normal position.

See Page 12 for Illustrations

INSTALLATION INSTRUCTIONS

BACKGUARD INSTALLATION

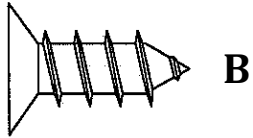

#8-18 x 5/8" long screw

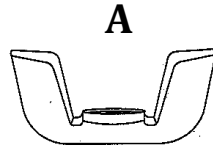

#10-24 wing nut

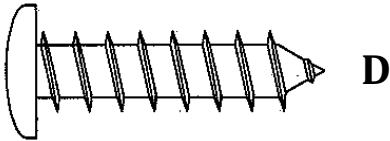
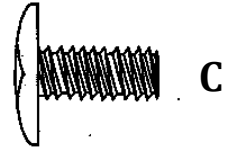

#10 x 1" long screw

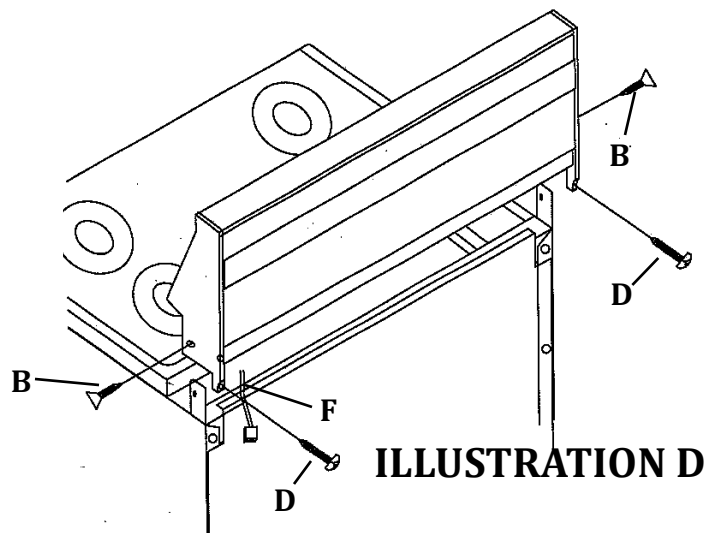
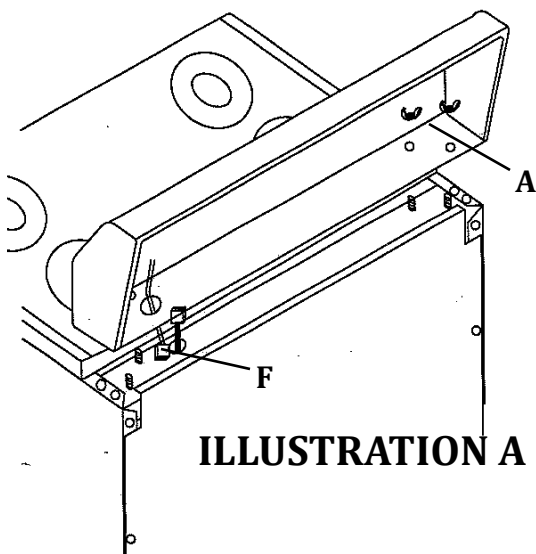
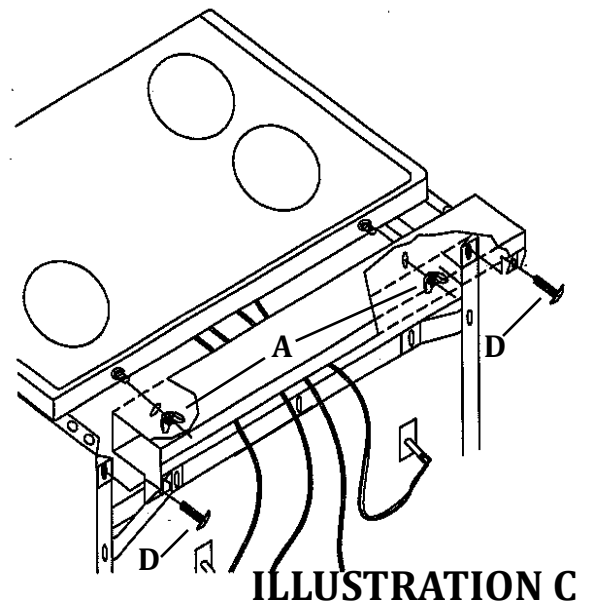
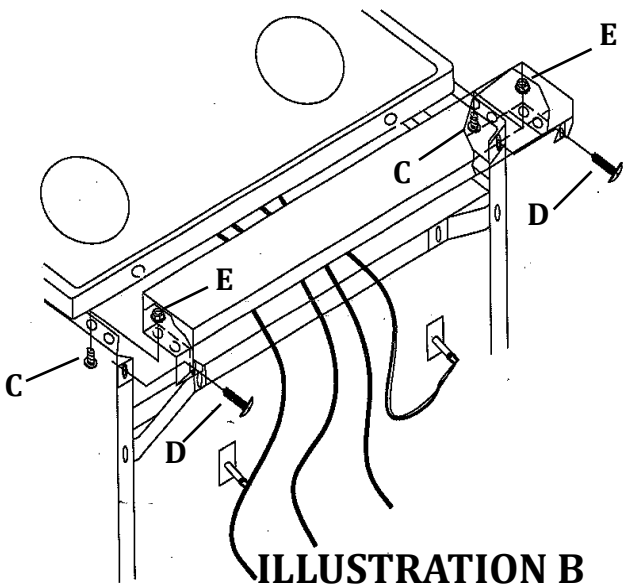
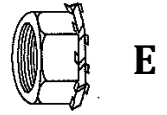

INSTALLATION INSTRUCTIONS

BE SURE RANGE IS PROPERLY INSTALLED AND GROUNDED BY A QUALIFIED TECHNICIAN.

IMPORTANT NOTE TO INSTALLER
BEFORE YOU BEGIN- DISCONNECT THE POWER TO THE RANGE AT THE MAIN CIRCUIT BREAKER
AND READ THESE INSTRUCTIONS COMPLETELY AND CAREFULLY.

BE SURE TO LEAVE THESE INSTRUCTIONS FOR THE LOCAL INSPECTORS USE.

MAXIMUM AND MINIMUM CLEARANCES

When installing a range around cabinets, use the recommended clearances given in Table X and the maximum and minimum clearances description given on this page in order to conform with safety standards.

The maximum depth of cabinets installed above cooking tops is **13 inches**.

Serious hazards are associated with reaching into storage cabinets above a range. To eliminate the risk of burns or fire by reaching over heated surface units, avoid locating cabinet storage space above the surface units. If storage cabinet is provided above a range equipped with a lower oven only, the hazard can be reduced by installing a range hood that projects horizontally a minimum of **5 inches** beyond the bottom of the cabinet.

The sides of the range can be flush to combustible material below the cooking top. The back of the range can be flush to combustible material. Zero clearance is permitted between the range and combustible construction extending from the cooking surface to **18 inches** above the level of the cooking surface.

13" MAXIMUM OVERHEAD

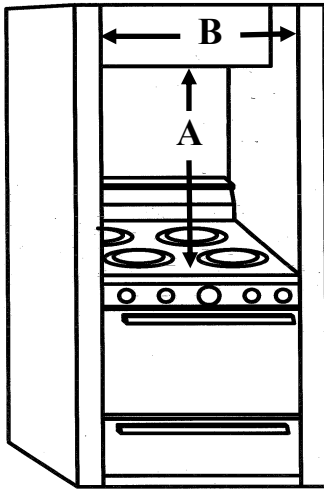

(A)-**30 inch** minimum clearance between the top of the cooking surface and the bottom of an unprotected wood or metal cabinet.

-or-

(A)- **24 inch** minimum when bottom of wood or metal cabinet is protected by not less than **1/4 inch** thick flame retardant millboard covered with not less than **No. 28 MSG** sheet steel, **0.015 inch** thick stainless, **0.024 inch** thick aluminum, or **0.020 inch** thick copper.

*** IMPORTANT: THE RANGE SIDE PANELS SHOULD STICK OUT BEYOND THE CABINET FRONTS AT LEAST 1/4" WHERE 0" CLEARANCE (FLUSH) OF SIDE WALLS IS DESIRED.**

⚠ WARNING: THE RANGE IS HEAVY AND REQUIRES MORE THAN ONE PERSON TO HANDLE IT. ALWAYS USE PROPER LIFTING METHODS AND WEAR GLOVES WHEN MOVING RANGE INTO POSITION.

ZERO SIDES AND BACK CLEARANCES ABOVE AND BELOW COOKTOP

NOMINAL WIDTH OF RANGE	RECOMMENDED MINIMUM INSTALLATION CLEARANCE (DIM. B)
20"	20 1/4"
24"	24 3/16"
30"	30 3/16"

CAUTION: NOT ALL CABINET AND BUILDING MATERIALS ARE DESIGNED TO WITHSTAND THE HEAT PRODUCED DURING THE NORMAL SAFE OPERATION OF A LISTED APPLIANCE. DAMAGE SUCH AS DISCOLORATION OR DELAMINATION MAY OCCUR.

INSTALLATION INSTRUCTIONS

BE SURE RANGE IS PROPERLY INSTALLED AND GROUNDED BY A QUALIFIED TECHNICIAN

ELECTRICAL REQUIREMENTS TO THE RANGE

This range requires a single phase, 3-wire 120-240 volt A.C. Electrical Circuit with a 60 Hertz frequency. Voltage and wattage rating is given on the number plate, located directly under the main top cooking surface. Installation must conform with local codes, or, in absence of local codes, with the National Electric Code, ANSI/NFPA No. 70– latest edition.

IMPORTANT: OBSERVE ALL GOVERNING CODES AND ORDINANCES.

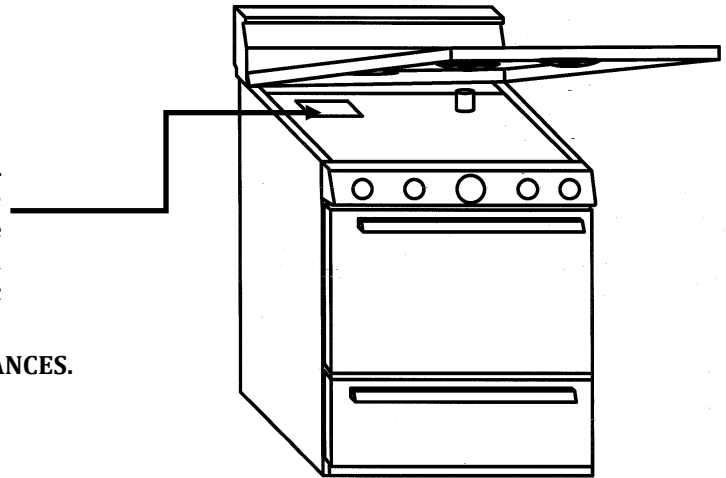

MOBILE HOME INSTALLATION

The installation of this range must conform with the Manufactured Home Construction and Safety Standards, Title 24 CFR, Part 3280 (formerly the Federal Standard for Mobile Home Construction and Safety, Title 24, HUD (Part 280) or, when such standard is not applicable, the Standard for Manufactured Home Installation, ANSI A 225.1/NFPA 501A, or with local codes. When this range is installed in a mobile home, it must be secured to the floor during transit. Any method of securing the range is adequate as long as it conforms to the standards listed above.

ELECTRICAL CONNECTIONS TO THE RANGE

Use only a 3-conductor, or if required a 4-conductor range cord. The range power-supply cord used must be rated **250 Volts 40 Amperes** and marked for use with ranges. The range power-supply cord must have open end spade lugs with upturned ends or closed-loop terminals.

NOTE: A 4-conductor cord is to be used only when the appliance is installed in a mobile home or where local codes do not permit grounding through the neutral.

TO MAKE A 3-CONDUCTOR CONNECTION:

1. Remove screws holding the terminal block cover plate located on the outer back of the range.
2. Insert range cable or connector through opening below terminal block.
3. Connect the cord strain relief to the power supply cord which must be securely attached to the cord set.
4. Connect the neutral (center) supply lead to the center connection on the terminal block.
5. Connect the 2 outside supply leads to the corresponding outside terminals.

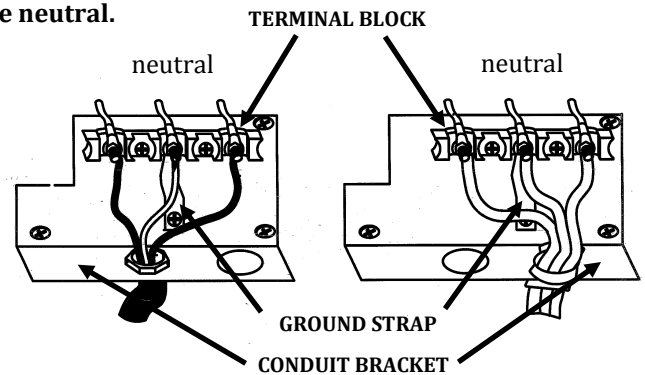

NOTE: Re-locate the conduit bracket for the selected electrical connection, cord or cable, center the conduit bracket below the terminal block Secure the (3) screws to range rear wall.

NOTICE TO INSTALLER: Replace the 3-conductor cord or cable with a 4-conductor cord or cable where grounding through the neutral conductor is prohibited in new installations, mobile homes, recreational vehicles or in other areas where local codes do not permit neutral grounding.

SPECIAL GROUNDING INSTRUCTIONS FOR 4-WIRE SYSTEMS

1. Remove the 3-conductor cord (if provided).
2. Disconnect the link from the neutral.
3. Use the grounding terminal or lead to ground unit in accordance with local codes.
4. Connect neutral terminal or lead to branch circuit neutral in usual manner (If the appliance is to be connected by means of a cord kit, use a 4-conductor cord for this purpose).

INSTALLATION INSTRUCTIONS

ANTI-TIP BRACKET INSTALLATION

The anti-tip bracket is installed to prevent the range from tipping forward as the result of excessive downward pressure on the open end of the oven door. All ranges are required to have an approved anti-tip bracket installed. The anti-tip bracket is packed in the oven section of the range. If you did not receive an anti-tip bracket with you purchase, call 1-800-858-5844.

	WARNING
	A child or adult can tip the range and be killed. Install the anti-tip device to the floor or the wall of the structure.
	Engage the range to the anti-tip device that is fastened to the wall or the floor. Re-engage the anti-tip device if the range is moved.

NOTICE: Parts supplied are for wood, concrete or ceramic tile floors. The plastic anchors are for mounting to concrete or ceramic floors or walls. Contact a qualified floor covering installer for the best procedure for drilling mounting holes through your type of floor covering.

STEP 1

It is necessary to determine the final location of the range before you can locate the anti-tip bracket. If the range is going to be located between cabinets, place the bracket so that **Edge A** sits flat against the rear wall. **Edge B** should just touch the side of the cabinet sitting to the **right side** of the range.

If there are no adjacent cabinets, align **Edge B** of the bracket with the edge of the range side. After the bracket has been placed mark the hole locations with a marker.

STEP 2

The anti-tip bracket can be attached to the floor or the wall. For wall mount application use **Location C**. When using location C, the screws must penetrate the wall sill plate located within the wall. For floor mount application use **Location D or E**. One screw on each side of the bracket is sufficient.

STEP 3

To mount anchor bracket to concrete or ceramic floor, use a drill with a 3/16" masonry bit to drill the two holes. Tap plastic anchor into mounting holes in floor with hammer. Line up holes in anti-tip bracket to holes in floor. Use the two screws provided to fasten anti-tip bracket to floor.

STEP 4

Unscrew the rear leg levelers approximately 1/2" so that the rear leg levelers will slide in under the anti-tip bracket. Slide range into the final position after completing the gas and electrical connections to the range.

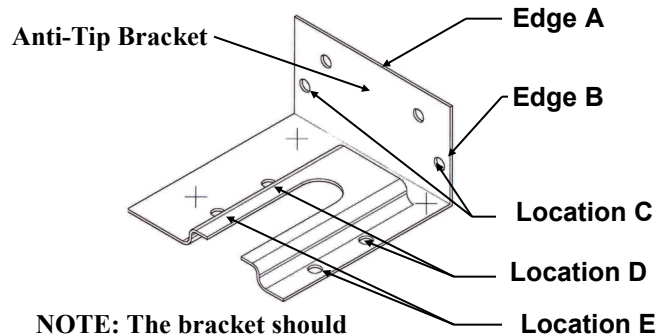

NOTE: The bracket should engage the right rear leg leveler.

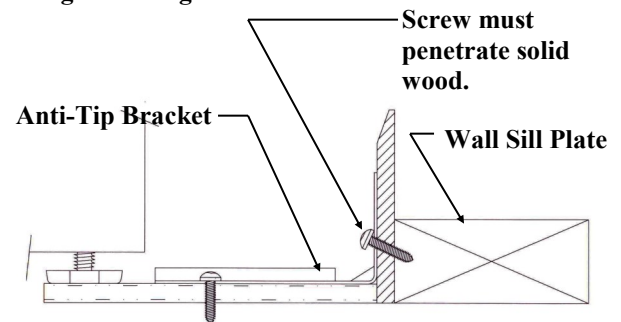

WARNING: IF RANGE IS EVER MOVED TO A DIFFERENT LOCATION, THE ANTI-TIP BRACKET MUST ALSO BE MOVED AND INSTALLED WITH THE RANGE.

BEFORE YOU CALL FOR SERVICE

Before you call for service, review this list. It may save you time and expense. This list includes common occurrences that are not the result of defective workmanship or materials in the appliance.

Find your problem here

Possible cause

OVEN OR SURFACE UNITS WILL NOT WORK AT ALL.

The plug on the range is not properly plugged into the electrical Outlet. **Before checking plug, disconnect the range power supply at the household distribution panel by removing the fuse or switching off the circuit breaker.**
The circuit breaker in your home has been tripped or a fuse has been blown.

OVEN WILL NOT WORK.

The Oven Control is not properly set. See Page 5.

SURFACE UNITS WILL NOT WORK.

The Surface Unit Controls are not properly set. Push in and turn to desired setting.
The Surface Units are not plugged in solidly. Coil Element ranges only
The drip pans are not set securely in the cooktop. Coil Element ranges only.

OVEN TEMPERATURE TOO HOT OR TOO COLD.

Oven Thermostat Control operation in the Broil Mode. Turn Oven Control to "OFF" and reset Oven Control rotating from "OFF" to the desired temperature.

BAKE ELEMENT CYCLES OFF AND ON.

This is normal for the bake element to cycle as the oven thermostat rises above and falls below the set temperature.

SMOKE OR ODOR ON INITIAL OVEN OPERATION.

This is normal during the first few times the oven is used.

FOOD DOES NOT BROIL PROPERLY.

Oven Thermostat Control not set properly. See Broiling Section Page 8.
Improper rack position. See Broiling Section Page 8.
Improper cookware being used.
Improper use of aluminum foil.

FOOD DOES NOT BAKE PROPERLY.

Oven Thermostat Control operation in the Broil Mode. Turn Oven Control to "OFF" and reset Oven Control rotating from "OFF" to the desired temperature.
Wrong oven rack location being used.
Incorrect cookware or improper size cookware is being used.
Vent Tube obstructed. Clear vent opening. See Page 5 for vent location.

OVEN LIGHT DOES NOT WORK.

The Oven Light Bulb is loose or defective. Tighten or replace. See Page 6.
The Oven Light Switch is not "ON".

Dear Consumer:

Your range will give you years of satisfaction service and pleasure when properly cared for and used. Producing an efficient range that conserves energy requires a considerable investment of time, effort & money.

Your range is engineered to surpass all performance and safety requirements. However, safety is also YOUR responsibility through proper use and care.

With this in mind, it is important that you read this booklet. Acquaint yourself with features and follow the use and care suggestions for complete satisfaction.

For questions concerning parts or service, refer to the enclosed limited warranty certificate. If you need assistance, call us at 1-800-858-5844 or contact us at www.premierrange.com.

The model and serial number is found on the number plate located beneath the main top on coil top ranges and beneath the storage drawer on ceramic smooth top ranges. Always include the complete model number, serial number, and color of range when ordering parts.

RECORD HERE FOR EASY REFERENCE:

Range Model Number _____ Color _____

Range Serial Number _____

Installation Date _____

Dealer's Name and Address _____

"Made in America" Policy Statement

Peerless-Premier Appliance Company is an American owned and privately held corporation for more than on hundred years. We proudly employ American workers a two manufacturing plants; Belleville, Illinois and Clinton, Kentucky. There has been discussion about the interpretation of the term "Made in America" since not every nut, screw and /or gas component may be made in America. The fact is, some of these components are made in other countries. Many of these components are not available from U. S. manufactures, which prevents us from using domestic made parts. PPAC uses as many U.S. made components as reasonably possible. Our efforts are to provide the highest quality products and remain competitive in our industry. All of our stamping, coating and assembly work is being completed at our two U.S. plants using hard working Americans.

We are a very proud American Company making American made products for our customers.

See our entire product line at:

www.PremierRange.com